

DISPLAY THIS CARD ON PRINCIPAL FRONTAGE OF WORK

CITY OF PORTLAND

SECTION

PERMIT

PERMIT ISSUED
SEP 14 2005
CITY OF PORTLAND

Permit Number 051220

Please Read Application And Notes, If Any, Attached

This is to certify that Huber Lare P/Owner

has permission to install a 9' x 24' deck

AT 149 Percival St

135 A003001

provided that the person or persons, firm or corporation accepting this permit shall comply with all of the provisions of the Statutes of Maine and of the ordinances of the City of Portland regulating the construction, maintenance and use of buildings and structures, and of the application on file in this department.

Apply to Public Works for street line and grade if nature of work requires such information.

Notification of inspection must be given and when permission procured before this building or part thereof is occupied or closed-in. HOUR NOTICE IS REQUIRED.

A certificate of occupancy must be procured by owner before this building or part thereof is occupied.

OTHER REQUIRED APPROVALS

Fire Dept. _____

Health Dept. _____

Appeal Board _____

Other _____

Department Name

9/14/05
Director - Building & Inspection Services

PENALTY FOR REMOVING THIS CARD

City of Portland, Maine - Building or Use Permit Application

389 Congress Street, 04101 Tel: (207) 874-8703, Fax: (207) 874-8716

Permit No: 05-1220	Issue Date: PERMIT ISSUED SEP 14 2005	135 A000001
Owner Address: 149 Percival St	Contractor Address: Portland	Phone: Phone
Permit Type:		Zone: R-5

Location of Construction: 149 Percival St	Owner Name: Huber Lare P
Business Name:	Contractor Name: Owner
Lessee/Buyer's Name	Phone:

Past Use: Single Family Home	Proposed Use: Single Family Home/ install a 9' x 24 deck
---------------------------------	---

Permit Fee: \$39.00	Cost of Work: \$1,800.00	CEO District: 4
------------------------	-----------------------------	--------------------

FIRE DEPT: <input type="checkbox"/> Approved <input type="checkbox"/> Denied <i>N/A</i>	INSPECTION: Use Group: <i>R-3</i> Type: <i>5B</i> <i>IRC 2003</i>
Signature:	Signature:

Project Description: 24'

PEDESTRIAN ACTIVITIES DISTRICT (P.A.D.)		
Action: <input type="checkbox"/> Approved <input type="checkbox"/> Approved w/Conditions <input type="checkbox"/> Denied	Signature: _____ Date: _____	

Permit Taken by <i>Huber</i>	Date Applied For: 08/22/2005	Zoning Approval		
---------------------------------	---------------------------------	------------------------	--	--

- This permit application does not preclude the Applicant(s) from meeting applicable State and Federal Rules.
- Building permits do not include plumbing, septic or electrical work.
- Building permits are void if work is not started within six (6) months of the date of issuance. False information may invalidate a building permit and stop all work..

Special Zone or Reviews
<input type="checkbox"/> Shoreland
<input type="checkbox"/> Wetland
<input type="checkbox"/> Flood Zone
<input type="checkbox"/> Subdivision
<input type="checkbox"/> Site Plan
Maj <input type="checkbox"/> Minor <input type="checkbox"/> MM <input type="checkbox"/>
Date: <i>9/14/05</i>

Zoning Appeal
<input type="checkbox"/> Variance
<input type="checkbox"/> Miscellaneous
<input type="checkbox"/> Conditional Use
<input type="checkbox"/> Interpretation
<input type="checkbox"/> Approved
<input type="checkbox"/> Denied
Date: _____

Historic Preservation
<input checked="" type="checkbox"/> Not in District or Landmark
<input type="checkbox"/> Does Not Require Review
<input type="checkbox"/> Requires Review
<input type="checkbox"/> Approved
<input type="checkbox"/> Approved w/Conditions
<input type="checkbox"/> Denied
Date: <i>9/14/05</i>

CERTIFICATION

I hereby certify that I am the owner of record of the named property, or that the proposed work is authorized by the owner of record and that I have been authorized by the owner to make this application as his authorized agent and I agree to conform to all applicable laws of this jurisdiction. In addition, if a permit for work described in the application is issued, I certify that the code official's authorized representative shall have the authority to enter all areas covered by such permit at any reasonable hour to enforce the provision of the code(s) applicable to such permit.

SIGNATURE OF APPLICANT ADDRESS DATE PHONE

RESPONSIBLE PERSON IN CHARGE OF WORK, TITLE DATE PHONE

All Purpose Building Permit Application

If you or the property owner owes real estate or personal property taxes or user charges on any property within the City, payment arrangements must be made before permits of any kind are accepted.

Location/Address of Construction: <u>149 PERCIVAL ST. PORTLAND</u>		
Total Square Footage of Proposed Structure <u>216</u>	Square Footage of Lot <u>9800</u>	
<input checked="" type="checkbox"/> Tax Assessor's Chart, Block & Lot Chart# <u>135</u> Block# <u>A</u> Lot# <u>3</u>	Owner: <u>LARE HUBER</u>	Telephone: <u>207 871 1190</u>
Lessee/Buyer's Name (If Applicable)	Applicant name, address & telephone: <u>LARE HUBER</u> <u>149 PERCIVAL 871 1190</u>	Cost of Work: \$ <u>1800⁰⁰</u> Fee: \$ <u>39</u> (approx.)
Current use: <u>Single family Residence</u> If the location is currently vacant, what was prior use: _____ Approximately how long has it been vacant: _____ Proposed use: <u>OUTDOOR ROCK - recreation</u> Project description: _____		<div style="border: 2px solid black; padding: 5px; width: fit-content; margin: auto;"> <p style="margin: 0;">DEPT. OF BUILDING INSPECTION CITY OF PORTLAND, ME</p> <div style="border: 1px solid black; padding: 5px; width: 80%; margin: 5px auto;"> <p style="margin: 0; text-align: center;">AUG 22 2005</p> </div> <p style="margin: 0; font-weight: bold; font-size: 1.2em;">RECEIVED</p> </div>
Contractor's name, address & telephone: Who should we contact when the permit is ready: <u>LARE HUBER</u> Mailing address: <u>149 PERCIVAL ST.</u> <u>PORTLAND, ME</u>		
We will contact you by phone when the permit is ready. You must come in and pick up the permit and review the requirements before starting any work, with a Plan Reviewer. A stop work order will be issued and a \$100.00 fee if any work starts before the permit is picked up.		PHONE: <u>871-1190</u>

Huber

Deck for 149 Perimeter
 Raised

Get sill

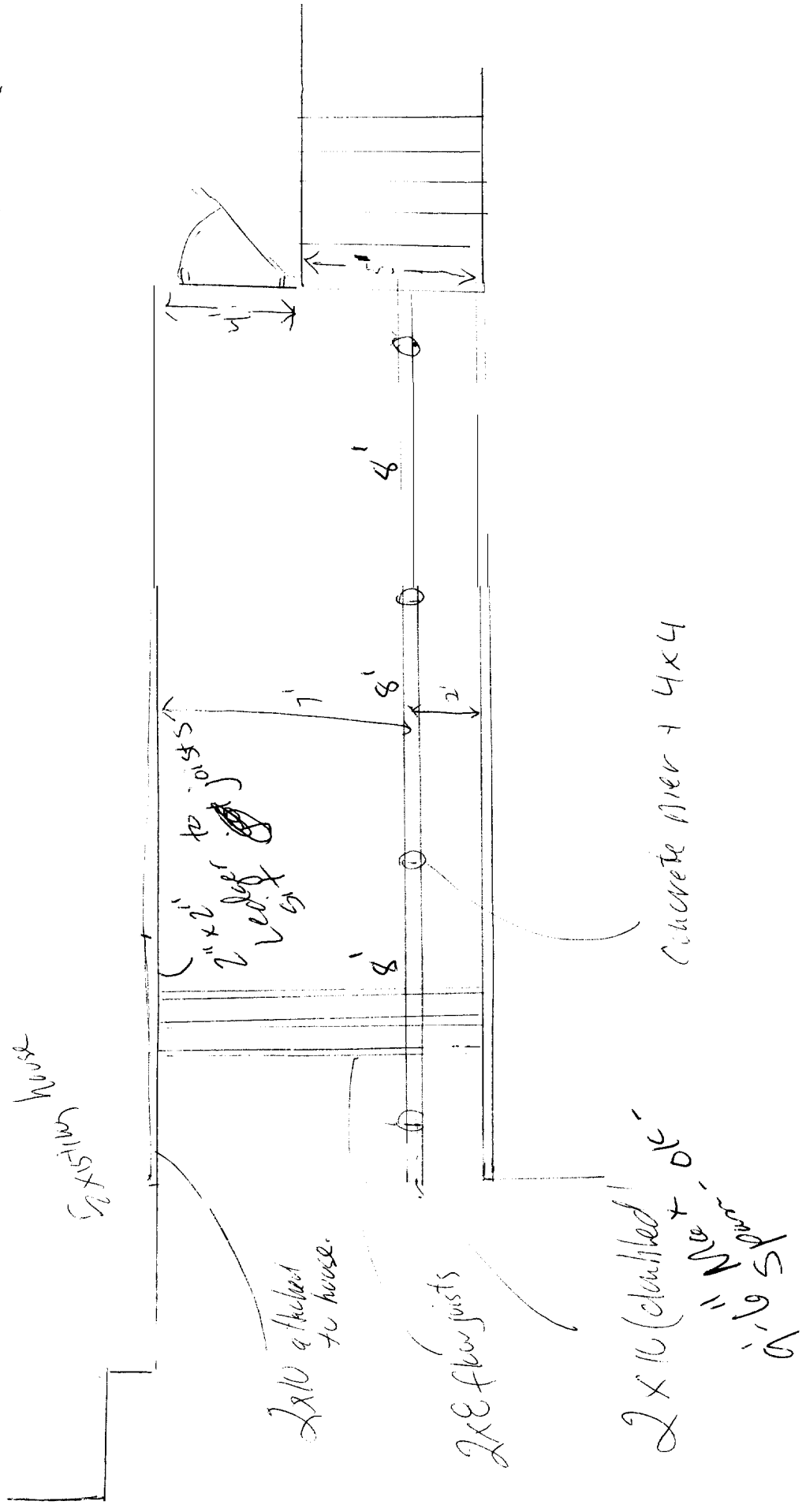

Existing house

2x10 attached to house.

2x8 floor joists

2x10 (classified) joists
 1/2" plywood

concrete pier + 4x4

Deck for 1419 PERCIVAL

HUBER

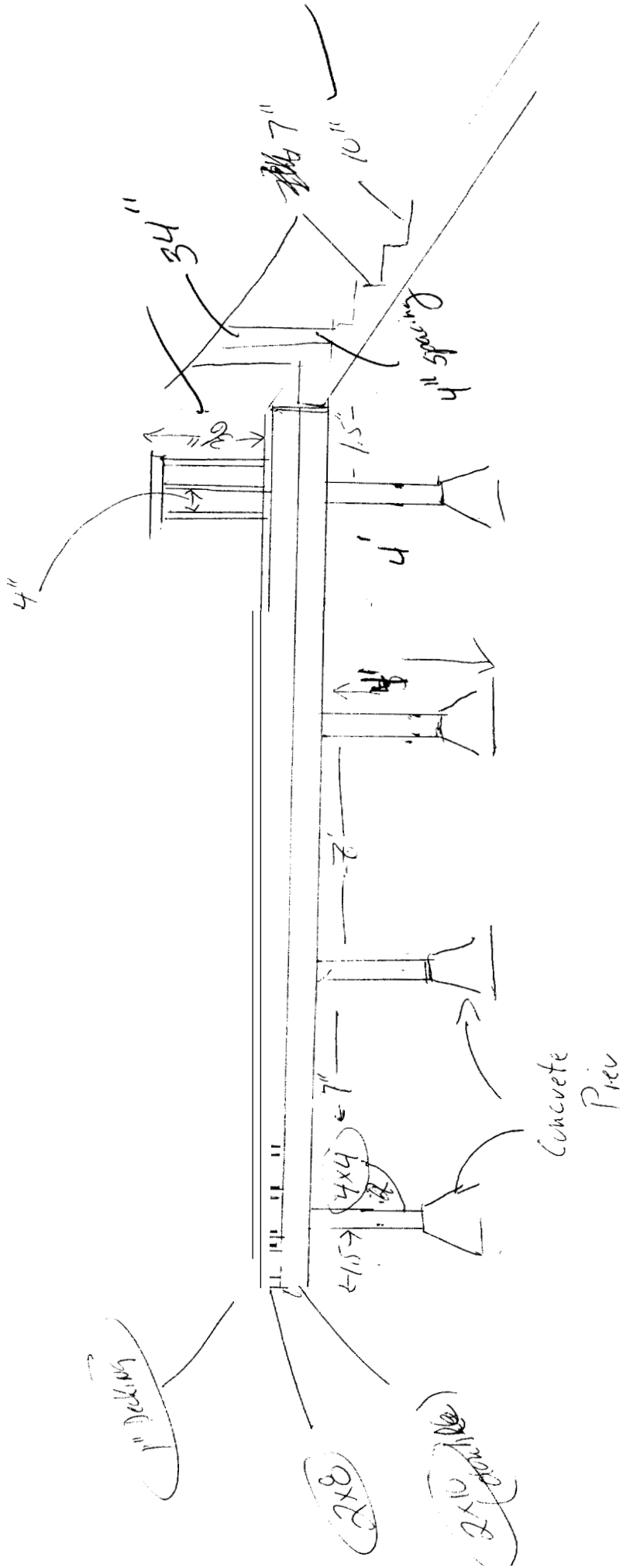

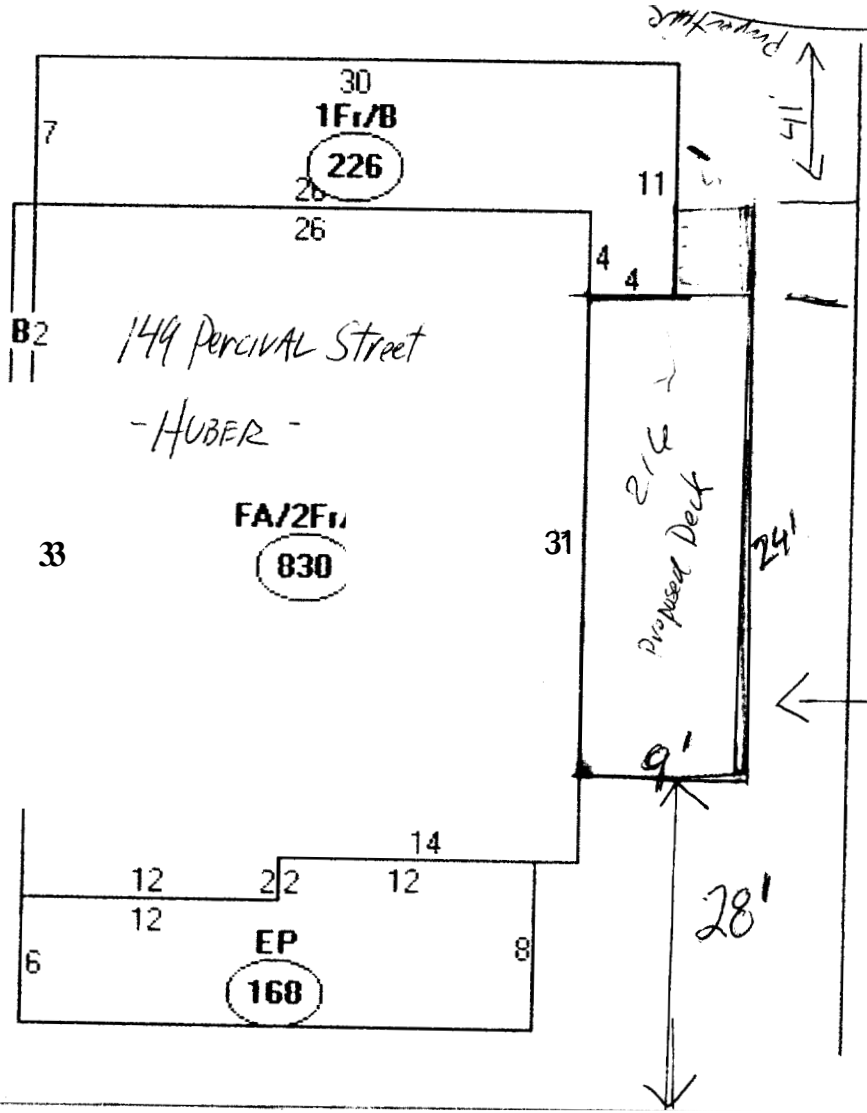

Descriptor/Area

A: FA/2Fr/B	830 sqft
B: FOH	12 sqft
C: 1Fr/B	226 sqft
D: EP	168 sqft
<hr/>	
	1236

Handwritten calculations and notes:

2.5
 5000
 x 40%

 2000
 - 1236

 764
 - 216

 548
 - 360

 188
 OK

Property Line

1 (PERCIVAL ST.)

City of Portland, Maine - Building or Use Permit

389 Congress Street, 04101 Tel: (207) 874-8703, Fax: (207) 874-8716

Permit No: 05-1220	Date Applied For: 08/22/2005	CBL: 135 A003001
------------------------------	--	----------------------------

Location of Construction: 149 Percival St	Owner Name: Huber Lare P	Owner Address: 149 Percival St	Phone:
Business Name:	Contractor Name: Owner	Contractor Address: Portland	Phone:
Tenant/Lessee/Buyer's Name	Phone:	Permit Type: Additions - Dwellings	

Proposed Use: Single Family Home/ install a 9' x 24' deck	Proposed Project Description: install a 9' x 24' deck
---	---

Dept: Zoning	Status: Approved	Reviewer: Tammy Munson	Approval Date: 09/14/2005
Note:			Ok to Issue: <input checked="" type="checkbox"/>
Dept: Building	Status: Approved with Conditions	Reviewer: Tammy Munson	Approval Date: 09/14/2005
Note:			Ok to Issue: <input checked="" type="checkbox"/>

1) Permit approved based on the plans submitted and reviewed w/owner/contractor, with additional information as agreed on and as noted on plans.

Please call 874-8703 or 874-8693 to schedule your inspections as agreed upon

Permits expire in 6 months, if the project is not started or ceases for 6 months.

The Owner or their designee is required to notify the inspections office for the following inspections and provide adequate notice, Notice must be called in 48-72 hours in advance in order to schedule an inspection:

By initializing at each inspection time, you are agreeing that you **understand** the inspection procedure and additional **fees** from a "Stop Work Order" and "Stop Work Order Release!" will be incurred if the procedure is not followed as stated below.

A Pre-construction Meeting will take place upon receipt of your building permit.

- Footing/Building Location Inspection:** Prior to pouring concrete
- Re-Bar Schedule Inspection:** Prior to pouring concrete.
- Foundation Inspection:** Prior to placing ANY backfill
- Framing/Rough Plumbing/Electrical:** Prior to any insulating or drywalling
- Final/Certificate of Occupancy:** Prior to any occupancy of the structure or use. **NOTE:** There is a \$75.00 fee per inspection at this point.

Certificate of Occupancy is not required for certain projects, *Your* inspector **can** advise you if your project requires a Certificate of Occupancy. *All* projects **DO** require a final inspection

 If any of the **inspections** do **not** occur, the project cannot **go** on to the **next** phase, **REGARDLESS OF THE NOTICE OR CIRCUMSTANCES.**

 CERIFICATE OF OCCUPANICES MUST BE ISSUED AND PAID FOR, BEFORE THE SPACE MAY BE OCCUPIED

Signature of Applicant/Designee

[Signature]
Signature of Inspections Official

Date

9.14.08

Date

CBL: 135A003 Building Permit #: 051220