

Revisions

Stephen Blatt  
Architects

5 South Street  
Post Office Box  
583 DTS  
Portland, Maine  
04112-0583  
Voice:  
207.761.5911  
Email:  
sbl@sbarchitects.com

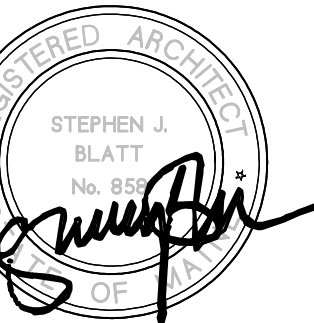

Consultants

Structural Engineer  
PINKHAM & GREER

Job No.: 16.05  
Date: MARCH 18, 2016  
Scale: 1/2" = 1'-0"  
Drawn by: CR  
Checked by: SJB

Drawing Title:  
ENLARGED PLANS,  
INTERIOR ELEVATIONS,  
KITCHENS & BATHS

A5.2

CONSTRUCTION SET

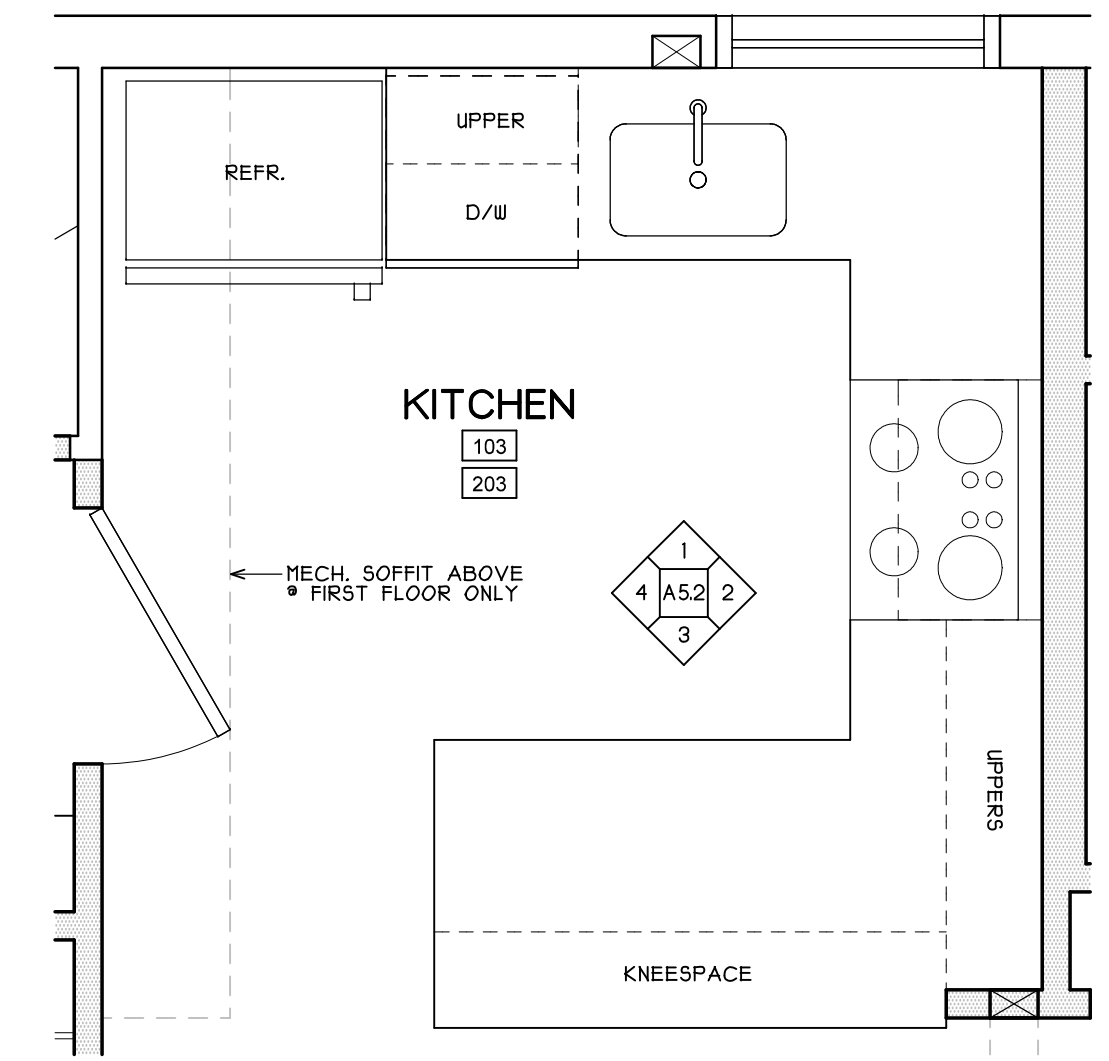

**A** KITCHEN PLAN - TYP. BOTH FLOORS  
A5.2 SCALE: 1/2"=1'-0"

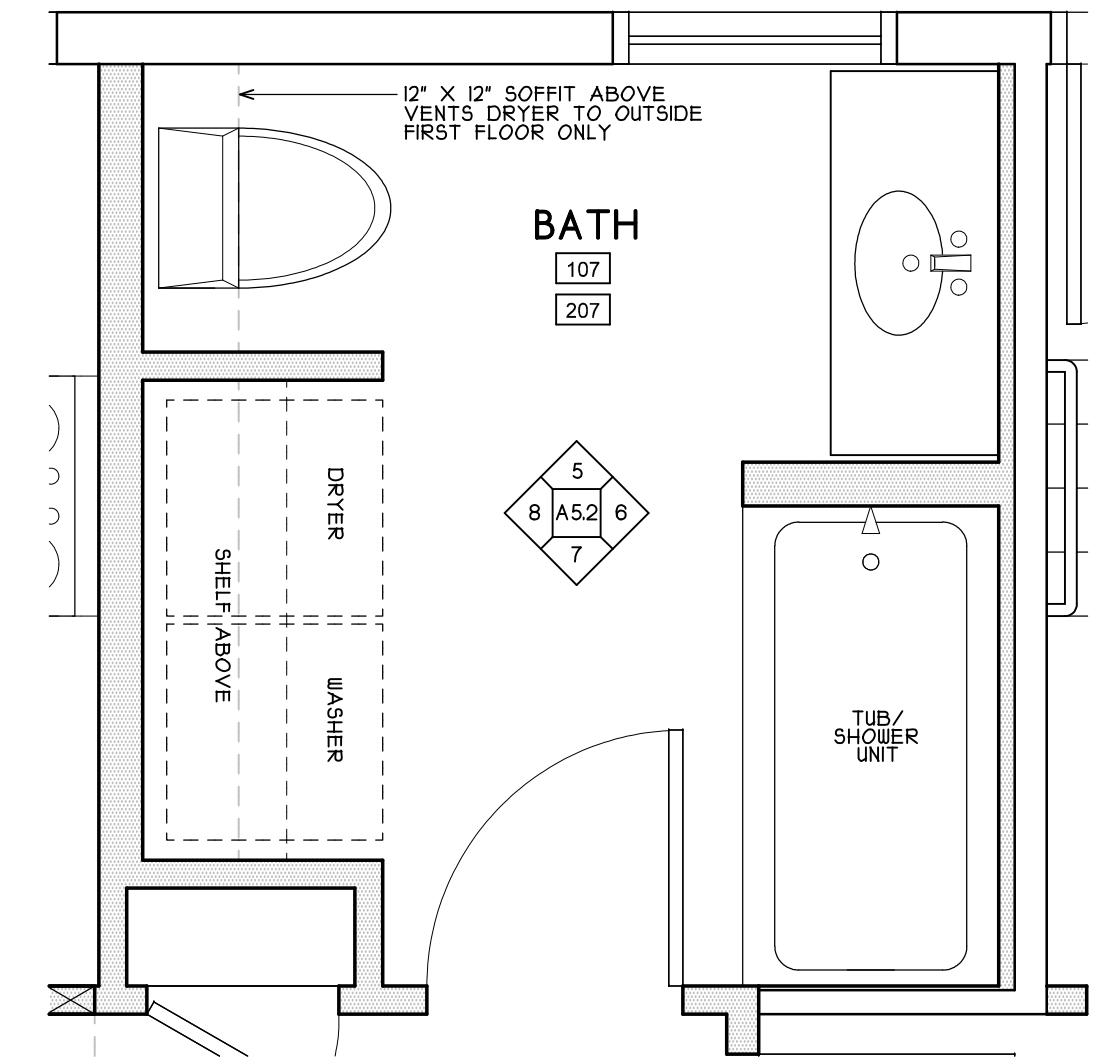

**B** BATH PLAN - TYP. BOTH FLOORS  
A5.2 SCALE: 1/2"=1'-0"

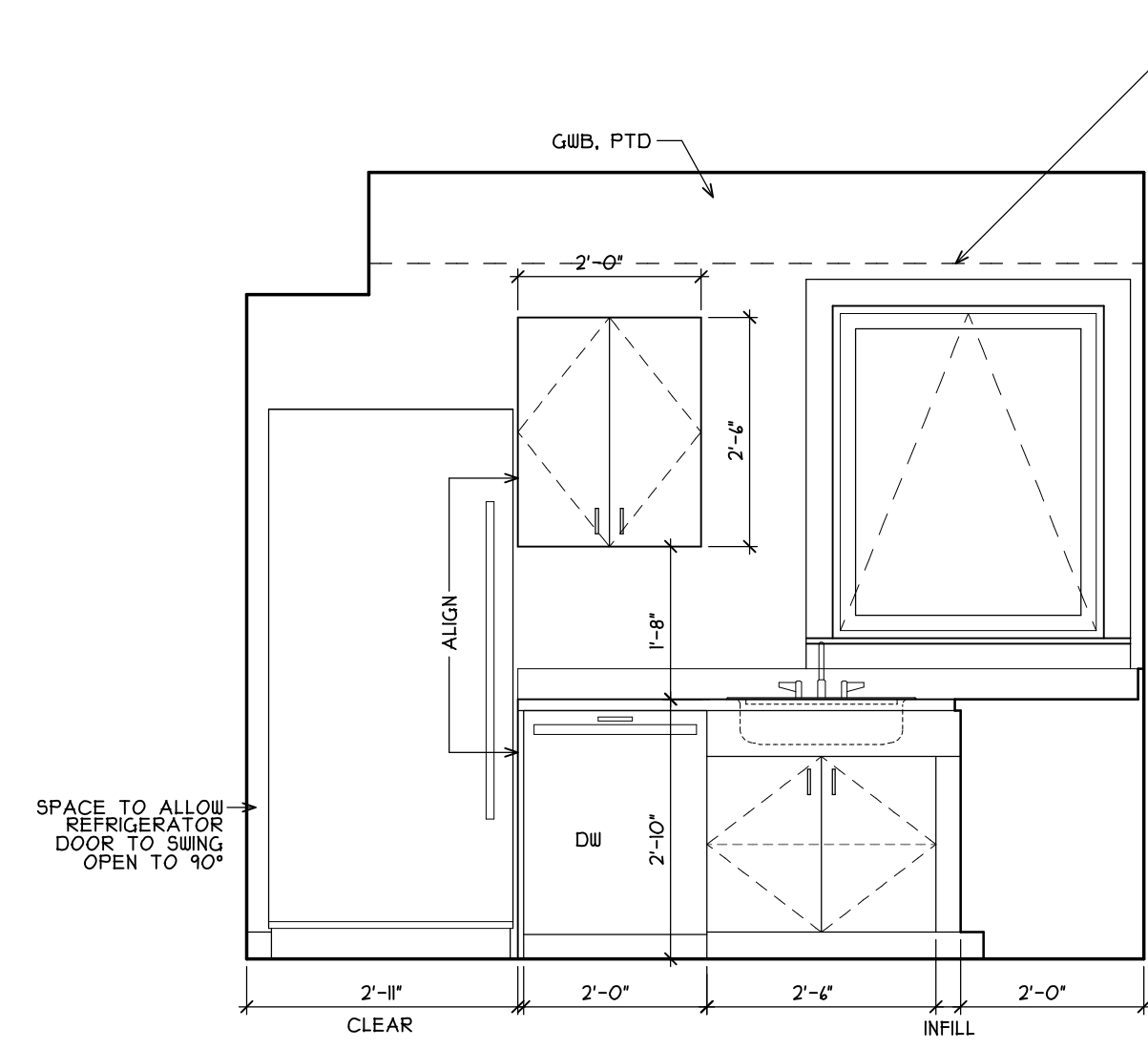

**1A** KITCHEN - FIRST FLOOR  
A5.2 SCALE: 1/2"=1'-0"

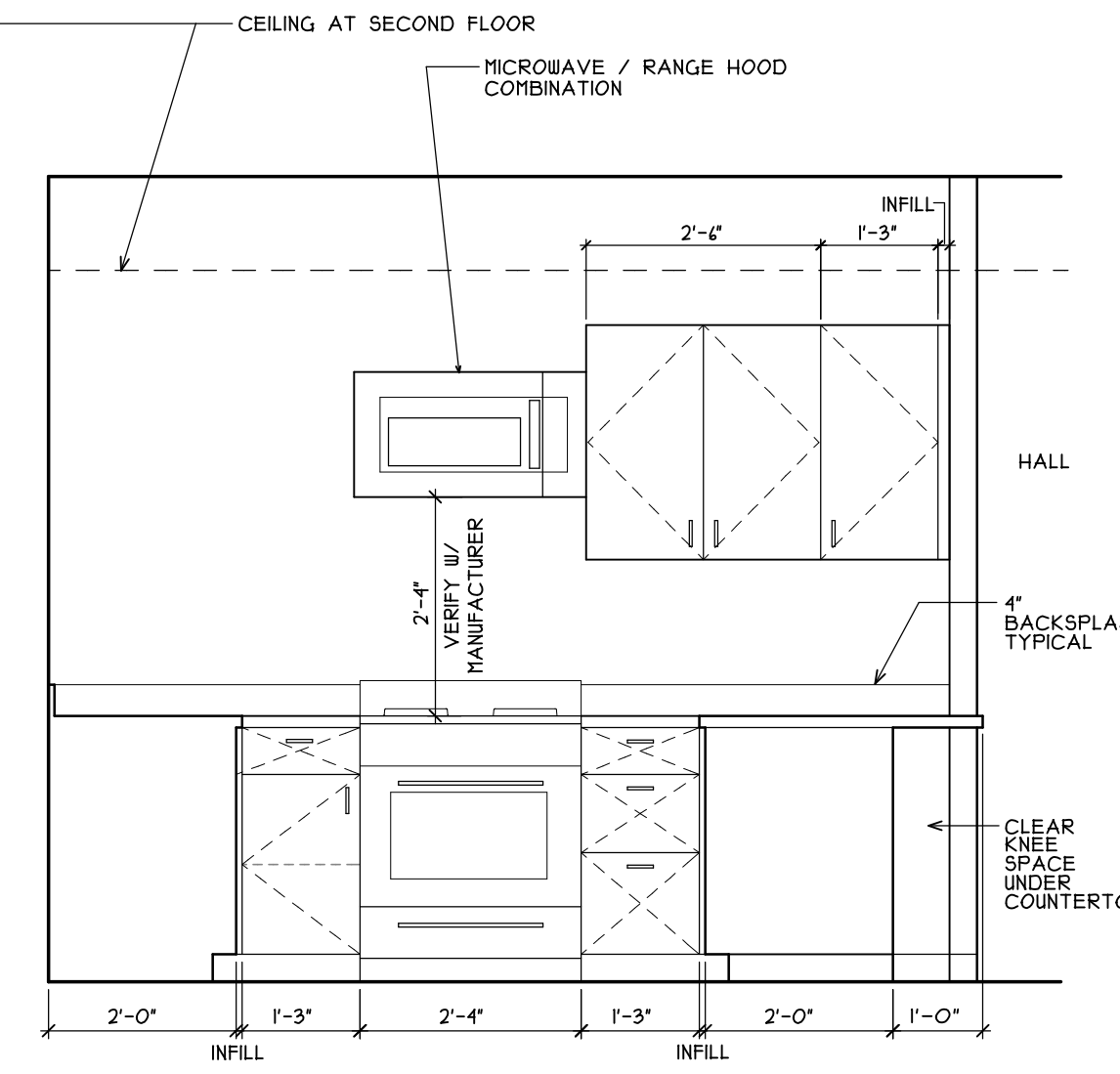

**2** KITCHEN, TYPICAL  
A5.2 SCALE: 1/2"=1'-0"

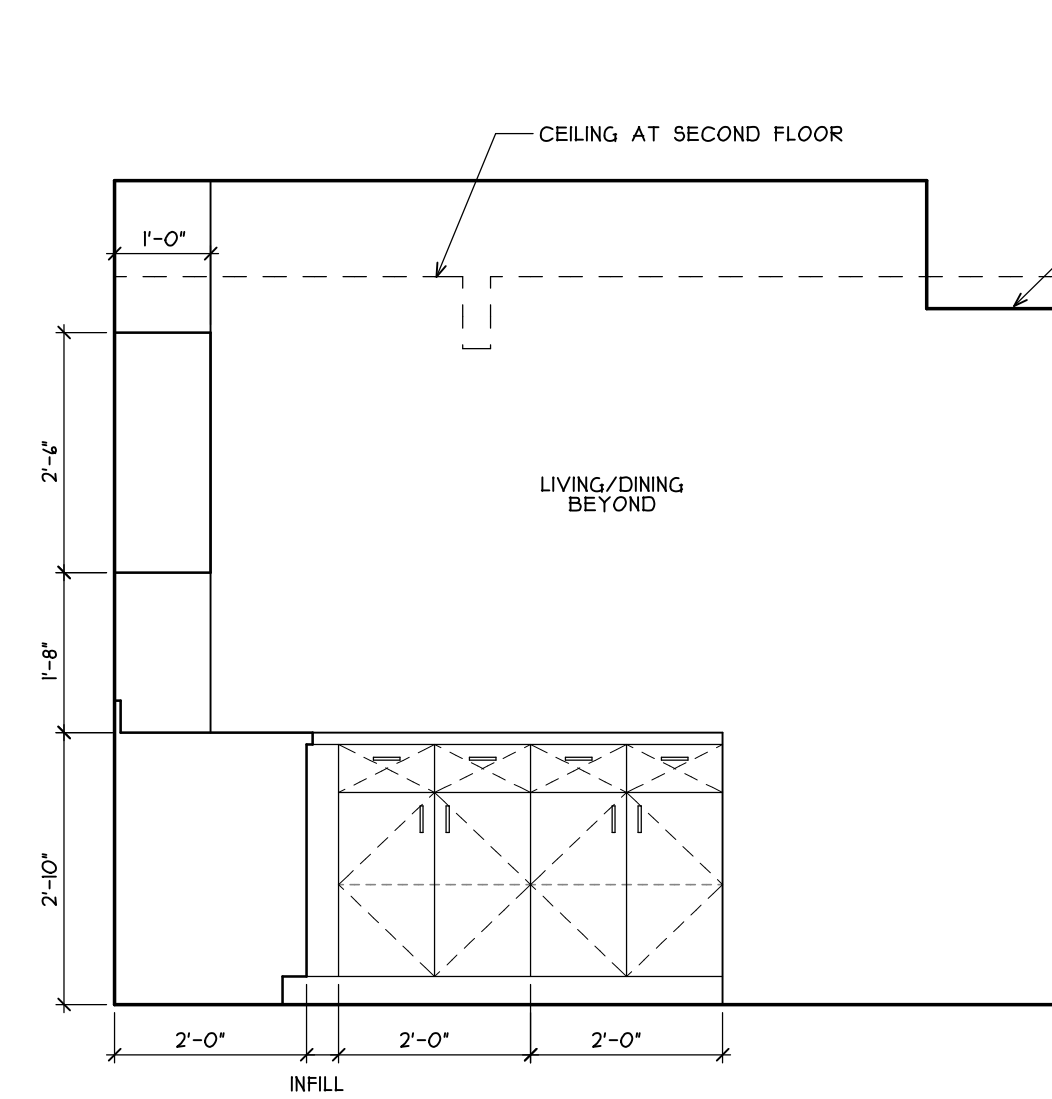

**3** KITCHEN, TYPICAL  
A5.2 SCALE: 1/2"=1'-0"

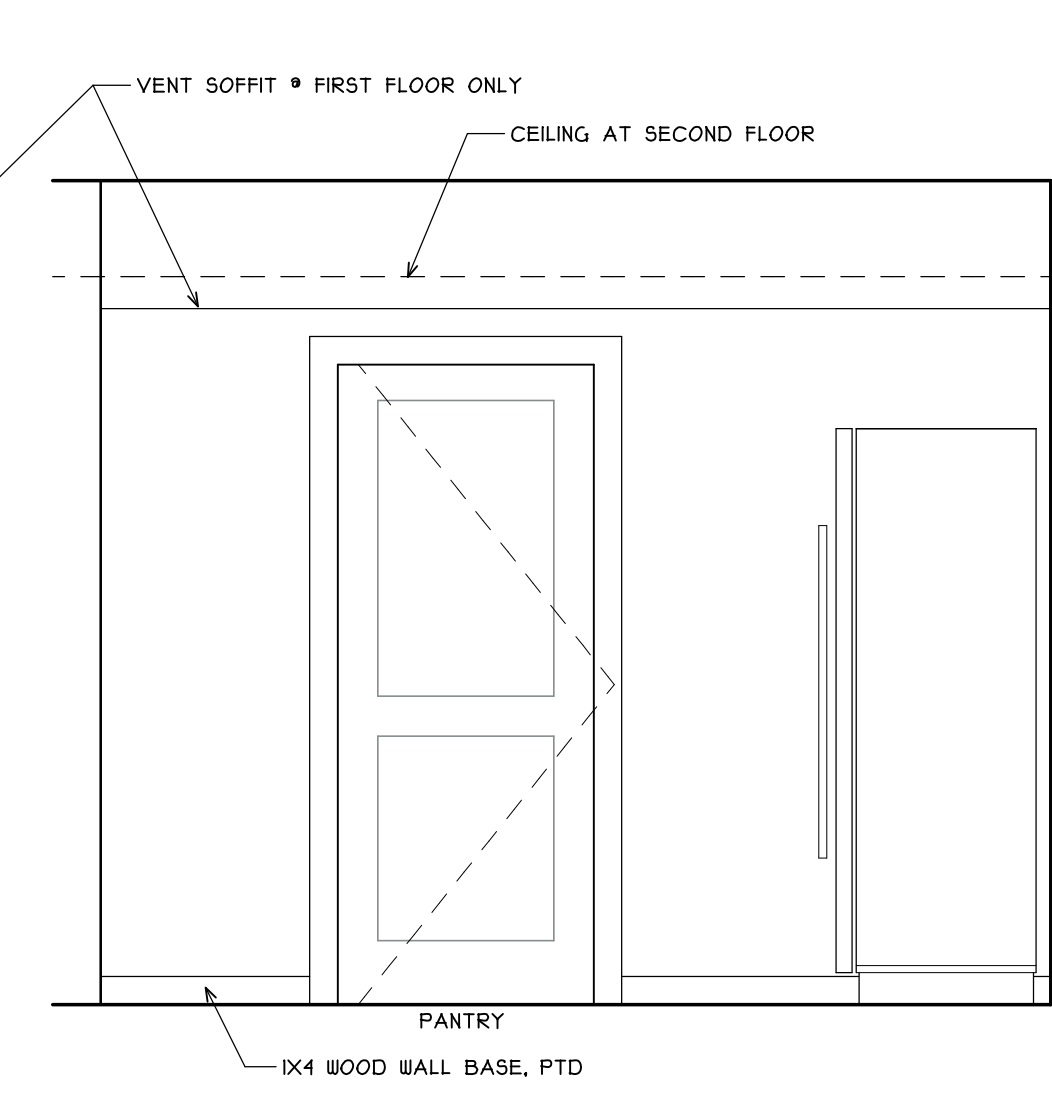

**4** KITCHEN, TYPICAL  
A5.2 SCALE: 1/2"=1'-0"

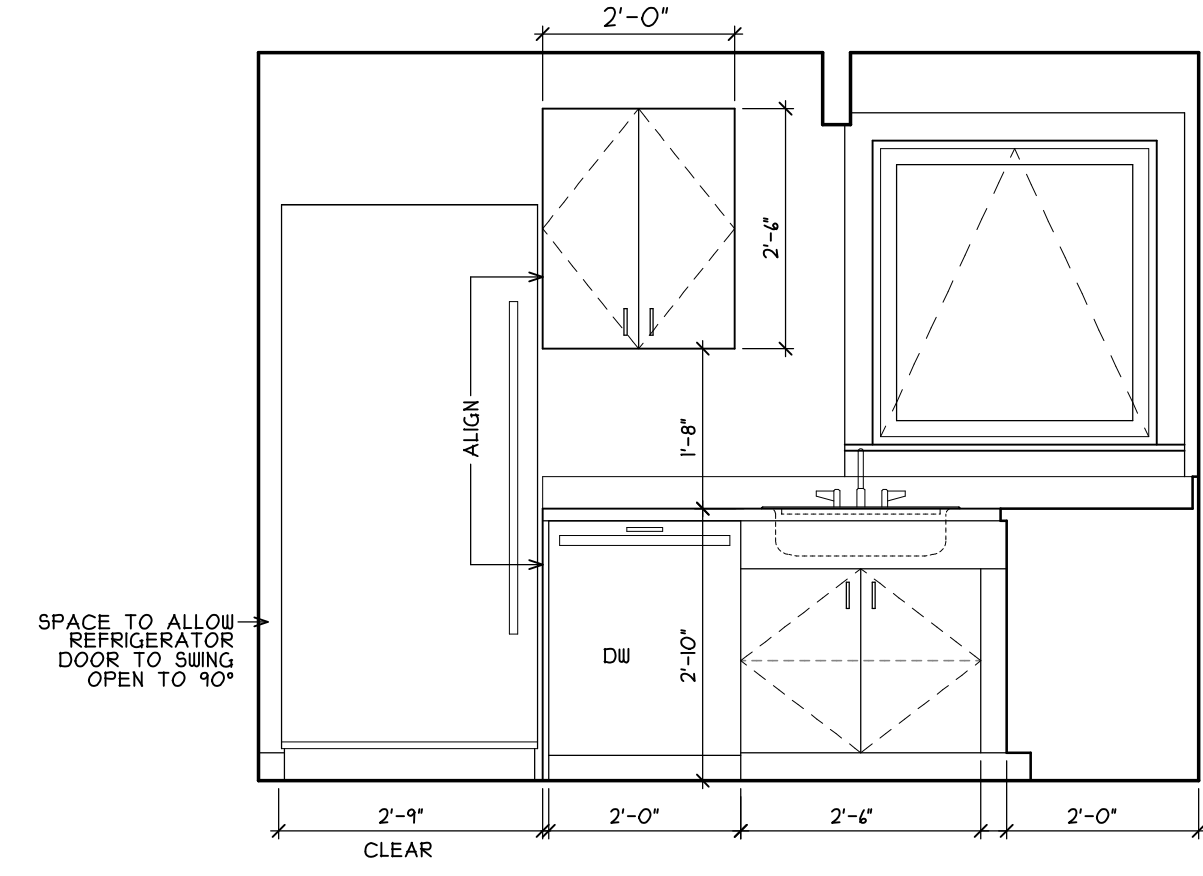

**1B** KITCHEN - SECOND FLOOR  
A5.2 SCALE: 1/2"=1'-0"

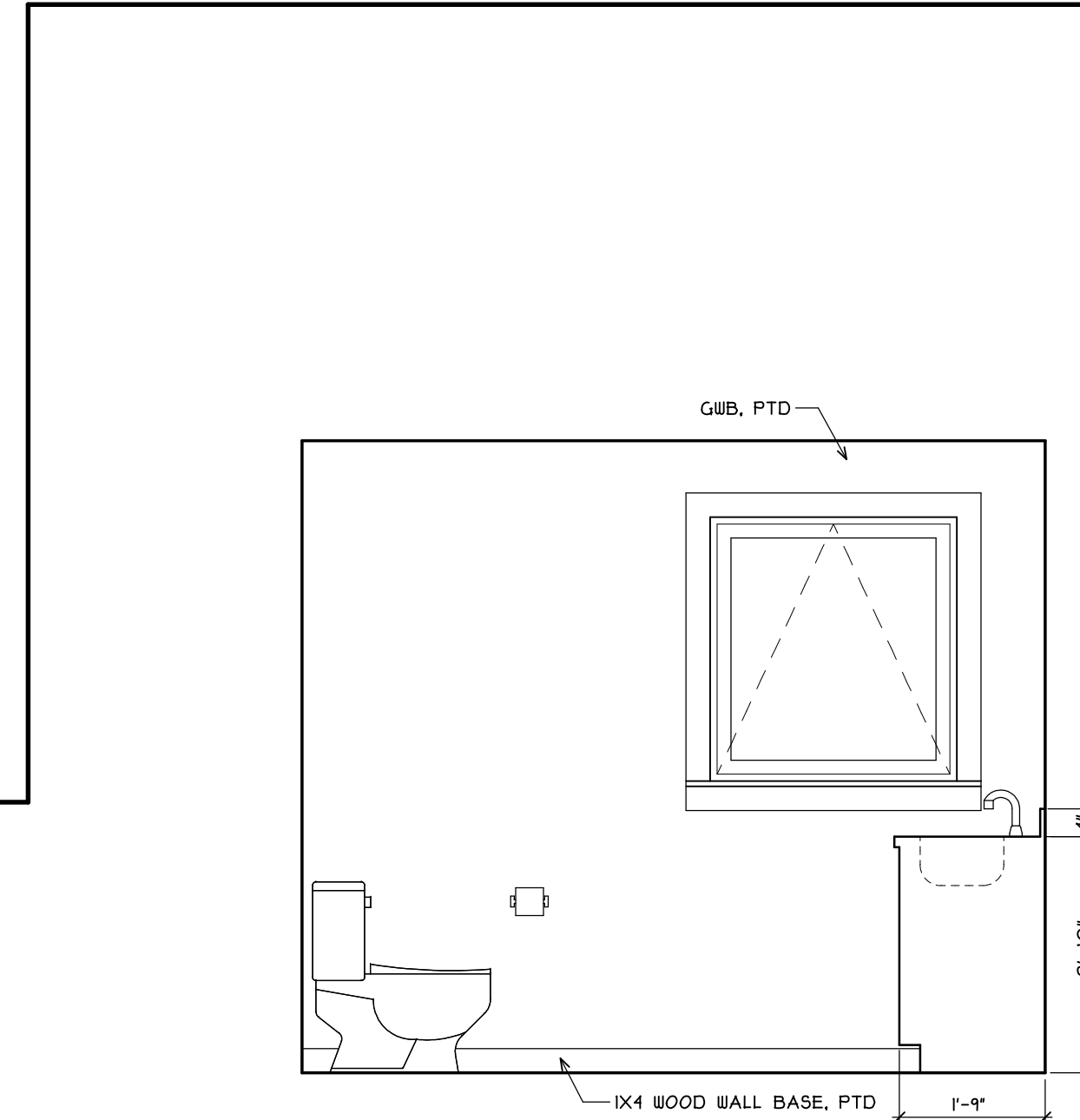

**5B** BATH - SECOND FLOOR  
A5.2 SCALE: 1/2"=1'-0"

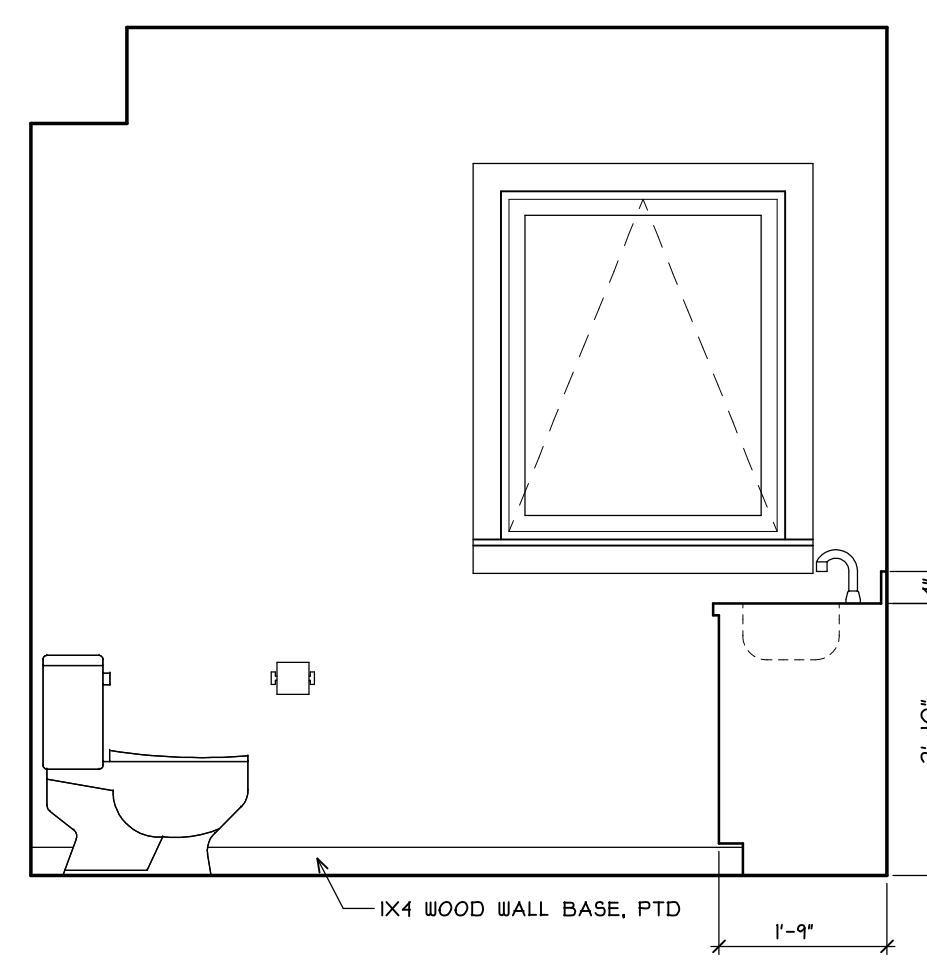

**5A** BATH - FIRST FLOOR  
A5.2 SCALE: 1/2"=1'-0"

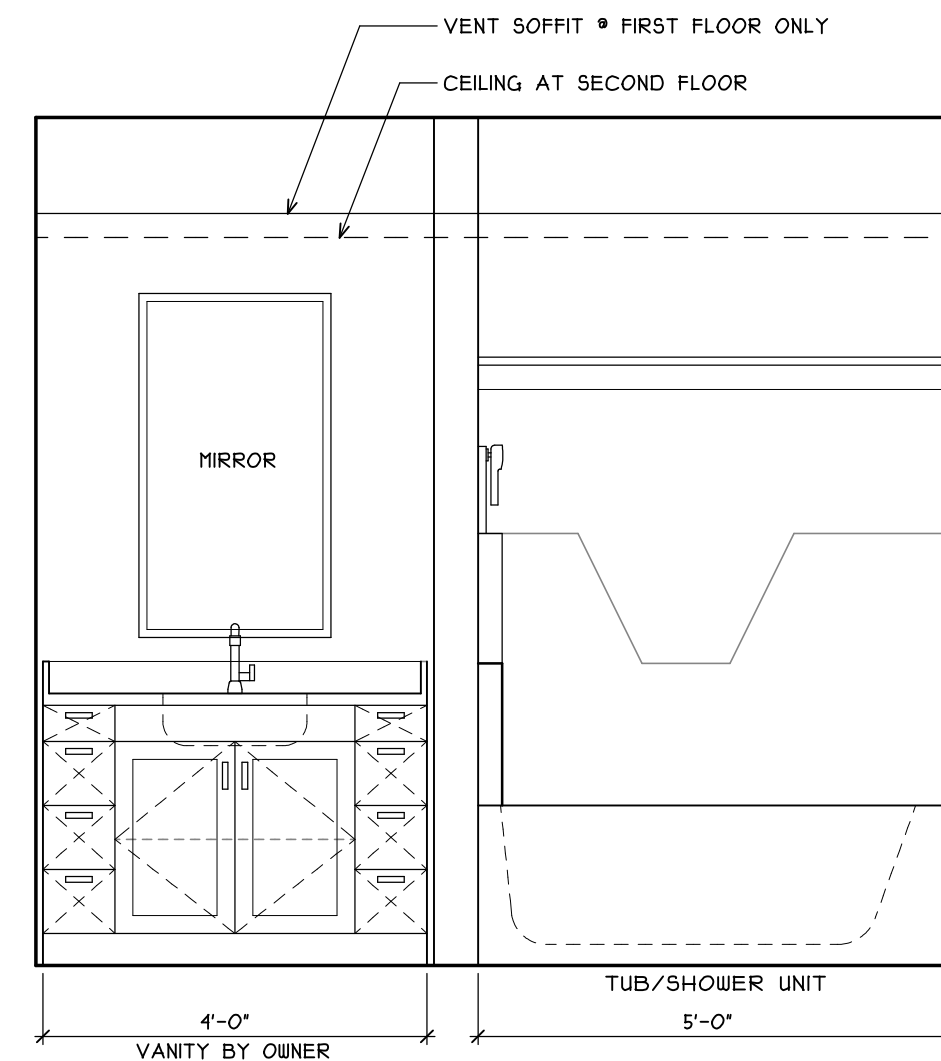

**6** BATH, TYPICAL  
A5.2 SCALE: 1/2"=1'-0"

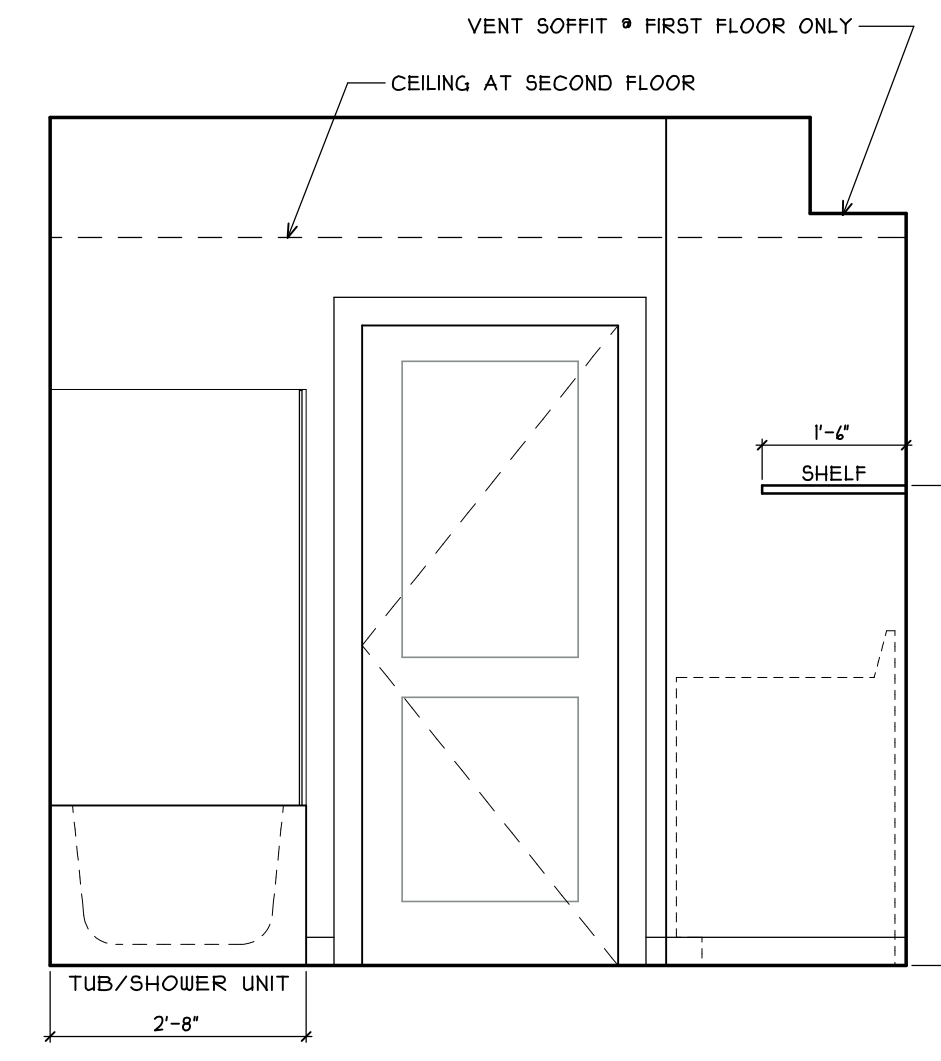

**7** BATH - FIRST FLOOR  
A5.2 SCALE: 1/2"=1'-0"

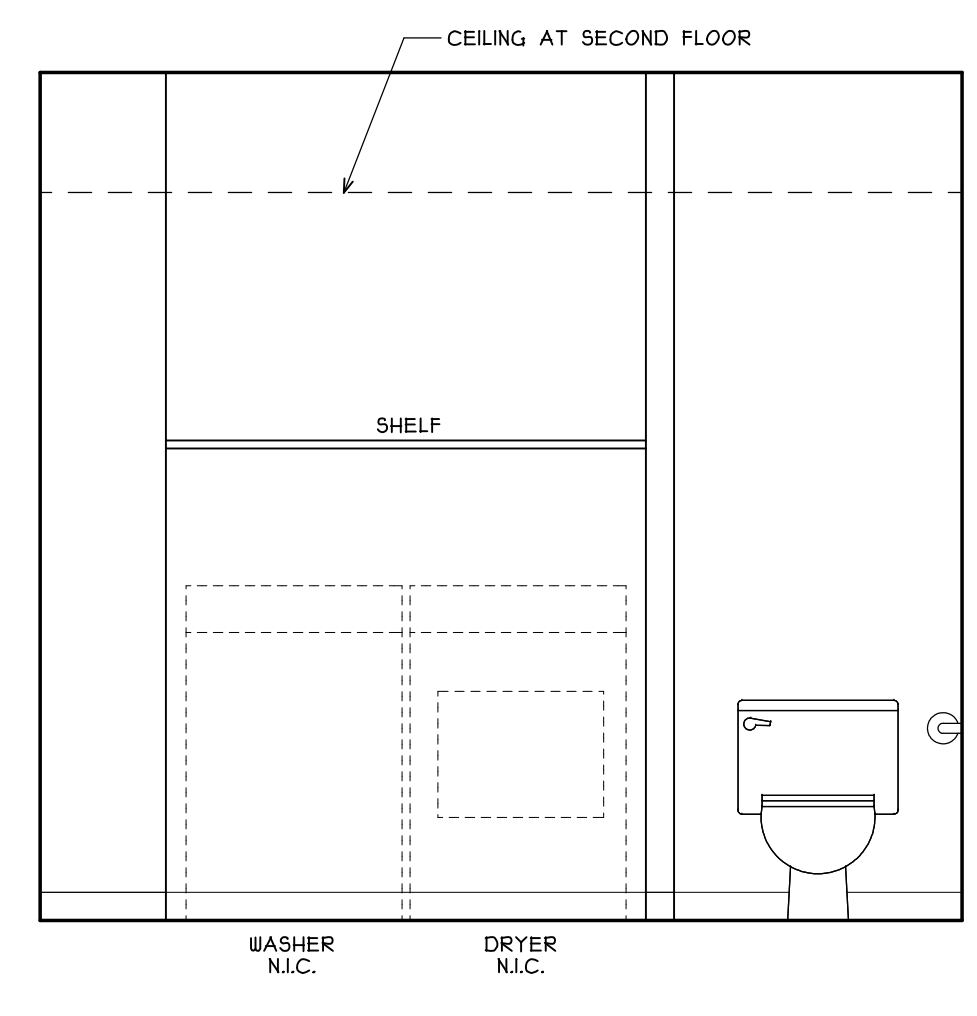

**8** BATH - FIRST FLOOR  
A5.2 SCALE: 1/2"=1'-0"