



CITY OF PORTLAND, MAINE

Portland Public Library

**RENOVATIONS TO THE BURBANK BRANCH
OF THE PORTLAND PUBLIC LIBRARY**

BID #XX15

**Issued for Permitting
February 06, 2015**

ARCHITECT

**Scott Simons Architects
75 York Street
Portland, ME 04101**

BURBANK BRANCH RENOVATIONS, PORTLAND PUBLIC LIBRARY

SECTION 000110 - TABLE OF CONTENTS

PROCUREMENT AND CONTRACTING REQUIREMENTS GROUP

DIVISION 00 – PROCUREMENT AND CONTRACTING REQUIREMENTS

INTRODUCTORY INFORMATION

000101	Project Title Page
000110	Table of Contents
000115	List of Drawing Sheet

PROCUREMENT AND CONTRACTING REQUIREMENTS

001116	Notice to Contractors
001119	Notice to Bidders
003100	Available Project Information Owner’s Tax Exemption Certificate
004213	Proposal Form
005000	Contracting Forms and Supplements
005213	Agreement Between City of Portland & Contractor

SPECIFICATIONS GROUP

GENERAL REQUIREMENTS SUBGROUP

DIVISION 01 - GENERAL REQUIREMENTS

011000	Summary
012300	Alternates
012500	Substitution Procedures
012600	Contract Modification Procedures
012900	Payment Procedures
013100	Project Management and Coordination
013200	Construction Progress Documentation
013300	Submittal Procedures
014000	Quality Requirements
014200	References
015000	Temporary Facilities and Controls
016000	Product Requirements
017300	Execution
017419	Construction Waste Management and Disposal
017700	Closeout Procedures
017839	Project Record Documents

FACILITY CONSTRUCTION SUBGROUP

DIVISION 02 - EXISTING CONDITIONS

024119	Selected Structure Demolition
--------	-------------------------------

BURBANK BRANCH RENOVATIONS, PORTLAND PUBLIC LIBRARY

DIVISION 03 – CONCRETE

033000 Cast-In-Place Concrete

DIVISION 04 - MASONRY

042000 Unit Masonry

DIVISION 05 - METALS

051200 Structural Steel-Specifications on Drawing Shhets

055000 Metal Fabrications

DIVISION 06 - WOOD, PLASTICS, AND COMPOSITES

061000 Rough Carpentry

062013 Exterior Finish Carpentry

064023 Interior Architectural Woodwork

DIVISION 07 - THERMAL AND MOISTURE PROTECTION

072100 Thermal Insulation

072616 Below-Grade Vapor Retarders

078413 Penetration Firestopping

079200 Joint Sealants

DIVISION 08 - OPENINGS

081113 Hollow Metal Doors and Frames

081416 Flush Wood Doors

085200 Wood Windows

087100 Door Hardware

088000 Glazing

DIVISION 09 - FINISHES

092300 Gypsum Plastering

092900 Gypsum Board

096400 Wood Flooring

096513 Resilient Base & Accessories

096813 Tile Carpeting

099113 Exterior Painting

099123 Interior Painting

DIVISION 10 – SPECIALTIES

102600 Wall and Door Protection

DIVISION 11 - EQUIPMENT – Not Used

BURBANK BRANCH RENOVATIONS, PORTLAND PUBLIC LIBRARY

DIVISION 12 – FURNISHINGS – Not Used

DIVISION 13 - SPECIAL CONSTRUCTION – Not Used

DIVISION 14 - CONVEYING SYSTEMS

142416 LULA Elevators

DIVISIONS 15 – 19 - NOT USED

FACILITY SERVICES SUBGROUP

DIVISION 21 – FIRE SUPPRESSION

DIVISION 22 – PLUMBING

Specifications on Drawing Sheets

DIVISION 23 – HEATING, VENTILATION, AND AIR-CONDITIONING (HVAC) [Attachments]

EF-3 Catalog Cut, 2 pages
Paddle Fan Catalog Cut, 2 pages
Systems 1, 3 and 5, Catalog Cuts, 2 pages
System 2, Catalog Cuts, 2 pages
System 4, Catalog Cuts, 3 pages
System 6, 7 and 8, Catalog Cuts, 3 pages

DIVISION 24 – NOT USED

Not Used

DIVISION 25 – INTEGRATED AUTOMATION

Not Used

DIVISION 26 – ELECTRICAL

Specifications on Drawing Sheets

DIVISION 27 – COMMUNICATIONS

Specifications on Drawing Sheets

DIVISION 28 – ELECTRONIC SAFETY AND SECURITY

DIVISION 29 – NOT USED

BURBANK BRANCH RENOVATIONS, PORTLAND PUBLIC LIBRARY

SECTION 00 01 15
LIST OF DRAWING SHEETS

GENERAL

G001 Cover Sheet
G002 Code Summary and Egress Plan

ARCHITECTURAL

AD100 Basement Demo Floor Plan
AD101 First Floor Demo Floor Plan
AD102 Second Floor Demo Floor Plan
A100 Basement Floor Plan
A101 First Floor Plan
A102 Second Floor Plan
A131 First & Second Reflected Ceiling Plan
A301 Elevator Section & Plans

STRUCTURAL

S000 Structural Notes
S100 Foundation /Second Floor Framing Plan & Section Details

PLUMBING

P1 Basement Plumbing Plan

MECHANICAL

M1 Basement Mechanical Plan
M2 First Floor Mechanical Plan
M3 Second Floor Mechanical Plan

ELECTRICAL

E0.0 Electrical Legends, Symbols & Notes
E0.1 Electrical Specifications
E1.0 Electrical Power & Systems Floor Plan, Basement
E1.1 Electrical Power & Systems Floor Plan, First Floor
E1.2 Electrical Power & Systems Floor Plan, Second Floor
E2.0 Electrical Lighting Schedule, Lighting & Fire Alarm Plan, Basement Plan
E2.1 Electrical Lighting Schedule, Lighting & Fire Alarm Plan, First Floor Plan
E2.2 Electrical Lighting Schedule, Lighting & Fire Alarm Plan, Second Floor Plan

END OF SECTION 00 01 15

CITY OF PORTLAND, MAINE

Notice to Contractors

**RENOVATIONS TO THE BURBANK BRANCH
OF THE PORTLAND PUBLIC LIBRARY**

Sealed bids will be received at the Purchasing Office, Room 103, City Hall, 389 Congress Street, Portland, Maine 04101, until 3:00 P.M., (DATE), at which time they will be publicly opened, for:

Project Name: **RENOVATIONS TO THE BURBANK BRANCH
OF THE PORTLAND PUBLIC LIBRARY**
Bid #XX15

Location: Burbank Branch
377 Stevens Avenue
Portland, Maine

Outline of Work: (Details ...)

MANDATORY PRE-BID CONFERENCE

It is mandatory that all prospective bidders attend a **mandatory pre-bid meeting held on (DATE), at 10:00 A.M.** This meeting will commence at the Burbank Branch of the Portland Public Library, located at 377 Stevens Avenue in Portland, Maine. Only those firms represented at this meeting will be allowed to submit a bid on this project.

Copies of the above documents will be available at the Purchasing Office, Room 103, City Hall, 389 Congress Street, Portland, ME 04101, upon payment in advance of \$75.00 for each set of plans and specifications or \$100.00 for each set of plans and specifications to be mailed. Each prospective bidder will be required to obtain from the City each copy of the proposal form and each set of plans; e-mail jrl@portlandmaine.gov, phone (207) 874-8654, or fax (207) 874-8652.

CITY OF PORTLAND, MAINE

CITY OF PORTLAND, MAINE

**RENOVATIONS TO THE BURBANK BRANCH
OF THE PORTLAND PUBLIC LIBRARY**

Notice to Bidders

Sealed bids for the above project, addressed to Purchasing office, City Hall, Room 103, 389 Congress Street, Portland, Maine 04101, and clearly marked on the outside of the envelope with the name of the bidder, project title and bid number, will be received **until 3:00 PM on (DATE)**, at which time they will be publicly opened.

All bids shall be submitted on the attached form and are to remain open for sixty (60) days after their opening. Late, faxed or bids submitted electronically will be rejected.

MANDATORY PRE-BID MEETING

There will be a **mandatory pre-bid meeting held on (DATE), at 10:00 A.M.** This meeting will commence at the Burbank Branch of the Portland Public Library, located at 377 Stevens Avenue. Only those firms represented at this meeting will be allowed to submit a bid on this project.

All questions shall be directed in writing ONLY to the Purchasing Office at the above address and be received at least five business days prior to the bid opening date (FAX 207-874-8652, or email MFF@portlandmaingov). Responses from the City that substantially alter this bid will be issued in the form of a written addendum to all bid holders registered in the Purchasing Office. Oral explanations or interpretations given before the award of the contract will not be binding.

Bids from vendors not registered with the Purchasing Office may be rejected; receipt of this document directly from the City of Portland indicates registration. Should a vendor receive this Invitation from a source other than the City, please contact 207-874-8654 to ensure that your firm is listed as a vendor for this project.

This bid will be awarded to the bidder that submits the lowest base bid amount.

The successful bidder shall agree to save the City harmless from all losses, costs or damages caused by his acts or those of his agents, and, before signing the contract, will produce evidence satisfactory to the Corporation Counsel of the City of Portland that he has secured Automobile and General Public Liability insurance coverage in the amount of not less than

four hundred thousand dollars (\$400,000) per person, one million Dollars (\$1,000,000) per occurrence for bodily injury, death and property damage, naming the City as an additional insured thereon, and shall also procure Worker's Compensation Insurance coverage, or written statement of exemption from Workers' Compensation coverage requirement. The successful bidder shall furnish and thereafter maintain certificates evidencing such coverage, which certificates shall guarantee thirty (30) days' notice of termination from insurance company or agent.

The successful bidder shall supply the City with a Performance Bond and Labor and Material Payment Bond, each in the amount of the contract price, guaranteeing one hundred percent (100%) performance of the contract, including the guarantee period and free and clear of any and all liens, attachments and encumbrances. All bonds shall comply with the requirements of Maine state law.

The City disclaims any and all responsibility for injury to contractors, their agents or others while examining the job or at any other time.

Materials and equipment purchased for permanent installation in this project are exempt from the State of Maine Sales and Use tax and from all Federal Excise taxes. Each bidder shall take this exception into account in calculating his bid price for the work.

The contractor shall furnish all labor, materials, fixtures, supplies, equipment and transportation necessary to do the work as specified. The contractor affirms that the equipment, or work, shall be in full compliance with any and all applicable O.S.H.A., D.O.T., ANSI, Federal, State and/or municipal regulations. **The City will obtain the building permit, however the Contractor will be responsible for acquiring all additional permits and/or licenses and pay all associated fees (including dump disposal fees and disposal taxes, if applicable), unless otherwise specified herein.**

The contractor shall erect and maintain, at all times, any and all safeguards necessary for the protection of life and property of all pedestrian and vehicular traffic. Note that this project will require care by the contractor to limit the disruption to visitors and Library staff and tenants. Delivery of materials shall be coordinated with the City's project manager.

It is the custom of the City of Portland, Maine to pay its bills 30 days following delivery of items, their acceptance, and receipt of invoices for, all items covered by the Purchase Order(s). In submitting bids under these specifications bidders should take into account all discounts, both trade and time allowed in accordance with this payment policy and quote a net price.

Equal Employment Opportunities. Vendor shall comply fully with the Nondiscrimination and Equal Opportunity Provisions of the Workforce Investment Act of 1998, as amended (WIA, 29 CFR part 37); the Nontraditional Employment for Women Act of 1991; title VI of the Civil Rights Act of 1964, as amended; section 504 of the Rehabilitation Act of 1973, as amended; the Age Discrimination Act of 1975, as amended; title IX of the Education Amendments of 1972, as amended; and with all applicable requirements imposed by or pursuant to regulations implementing those laws, including but not limited to 29 CFR part 37, and all other applicable laws, including the Maine Human Rights Act, ordinances and regulations regarding equal opportunity and equal treatment.

The City reserves the right to waive any informalities in bids, to accept any bid or portions thereof (bidders are advised to note this and quote accordingly) and to reject any or all bids should it be deemed for the best interest of the City to do so. The City reserves the right to substantiate the bidder's qualifications, capability to perform, availability, past performance record and to verify that the bidder is current in its obligations to the City, as follows:

Pursuant to City procurement policy and ordinance, the City is unable to contract with businesses or individuals who are delinquent in their financial obligations to the City. These obligations may include but are not limited to real estate and personal property taxes and sewer user fees. Bidders who are delinquent in their financial obligations to the City must do one of the following: bring the obligation current, negotiate a payment plan with the City's Treasury office, or agree to an offset which shall be established by the contract which shall be issued to the successful bidder.

September XX, 2014

Matthew F. Fitzgerald
Purchasing Manager

BURBANK BRANCH RENOVATIONS, PORTLAND PUBLIC LIBRARY

DOCUMENT 00 31 00 – AVAILABLE PROJECT INFORMATION

1.1 AVAILABLE PROJECT INFORMATION

- A. This Document with its referenced attachments is part of the Procurement and Contracting Requirements for Project. They provide Owner's information for Bidders' convenience and are intended to supplement rather than serve in lieu of Bidders' own investigations. They are made available for Bidders' convenience and information, but are not a warranty of existing conditions. This Document and its attachments are not part of the Contract Documents.
- B. Construction Documents for previous building renovations of June 8, 1994 by Van Dam and Renner Architects
- C. Hazardous Material Report of January 10, 1994 by Northeast Test Consultants
- D. Asbestos Abatement Report of January 20, 1995 by Northeast Test Consultants

1.2 ACCESS INSTRUCTIONS

- A. The available project information can be accessed at either of the following two links:
 - 1. <https://drive.google.com/folderview?id=0B8RXQI-ojc8wRFBuQWY4WlgzZ2s&usp=sharing>
 - 2. <http://tinyurl.com/burbankinfo>

END OF DOCUMENT 00 31 00

Internal Revenue Service

Date: February 8, 2006

PORTLAND PUBLIC LIBRARY
% PRESIDENT
5 MONUMENT SQ
PORTLAND ME 04101-4017

**Department of the Treasury
P. O. Box 2508
Cincinnati, OH 45201**

Person to Contact:
Dee Anna Jarmon 31-03084
Customer Service Specialist
Toll Free Telephone Number:
877-829-5500
Federal Identification Number:
01-6000802

Dear Sir or Madam:

This is in response to your request of February 8, 2006, regarding your organization's tax-exempt status.

In January 1943 we issued a determination letter that recognized your organization as exempt from federal income tax. Our records indicate that your organization is currently exempt under section 501(c)(3) of the Internal Revenue Code.

Our records indicate that your organization is also classified as a public charity under sections 509(a)(1) and 170(b)(1)(A)(vi) of the Internal Revenue Code.

Our records indicate that contributions to your organization are deductible under section 170 of the Code, and that you are qualified to receive tax deductible bequests, devises, transfers or gifts under section 2055, 2106 or 2522 of the Internal Revenue Code.

If you have any questions, please call us at the telephone number shown in the heading of this letter.

Sincerely,

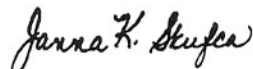

Janna K. Skufca, Director, TE/GE
Customer Account Services

PROPOSAL

Proposal of _____

Name

Address

The name and address shown on the above lines shall be the official name and address of the person, partnership or corporation submitting this bid and shall agree with the "Signature of Bidder" in the case of an individual; the "Name of Firm or Partnership" in the case of a firm or partnership; the "Name of Bidder" in case of a corporation.

TO: Matthew F. Fitzgerald, Purchasing Manager
City Hall, Room 103
389 Congress Street
Portland, ME 04101

The undersigned having carefully examined the site of the work; the Plans; Standard Specifications, including all current amendments or revisions there of; the Supplemental Specification, Special Provisions; Contract Agreement and Contract Bonds, where applicable, contained herein for the **Renovation to the Burbank Branch of the Portland Public Library** on which proposals will be received until the time specified in this bid document; and in case of award, do(es) hereby propose and offer to enter into a contract to supply all the materials, tools, equipment and labor required to perform and construct the whole of the work in strict accordance with the terms and conditions of this contract at lump sum price stated in the following Price Proposal Page submitted by the undersigned.

This Proposal may be accepted by the City of Portland at any time within ninety (90) calendar days after opening of the bids.

**PRICE
PROPOSAL**

The undersigned having examined the attached document do(es) hereby propose and offer to enter into a contract to supply all the materials, tools, equipment and labor required to perform and construct the whole of the work in strict accordance with the terms and conditions of this contract at the price stated in the following Proposal:

TOTAL PRICE: \$ _____
(Award Basis)

TIME FOR COMPLETION FROM START OF WORK: _____

WARRANTY OF LABOR: _____

WARRANTY OF MATERIALS: _____

The undersigned also agrees as follows:

FIRST: To do any extra work which may be ordered, and to accept as full compensation therefore such prices as may be agreed upon in writing by the Architect and the Contractor; or in case no agreement is made, to accept as full compensation the amount determined upon a "force account" basis as provided in the M.D.O.T. Standard Specifications, Revision of December, 2002.

SECOND: To begin work on the date specified in the Architect's "Notice to Commence Work" as mutually agreed and to prosecute said work in such a manner as to complete it in the time stated on this proposal.

THIRD: That this offer is to continue open to acceptance until the formal contract is executed by the successful bidder of this work, and the City may at any time without notice accept this proposal whether any other proposal has previously been accepted or not. Provided, however, that the City will accept, in writing, one of the proposals made, or reject all proposals made, within ninety (90) calendar days after the date of opening of the proposals.

The undersigned as Bidder, declares that the only persons or parties interested in this Proposal are those named herein; that the bidder is not financially interested in, or otherwise affiliated in a business way with any other bidder on this contract; and that this Proposal is made without collusion with any other person, firm or corporation.

The undersigned declares that any person(s) employed by the City of Portland, Maine, who has direct or indirect personal or financial interest in this proposal or in any portion of the profits which may be derived therefrom, has been identified and the interest disclosed by separate attachment. (Please include in your disclosure any interest which you know of. An example of a direct interest would be a City employee who would be paid to perform services under this proposal. An example of an indirect interest would be a City employee who is related to any officers, employees, principal or shareholders of your firm or you.) If in doubt as to status or interest, please disclose to the extent known.

Respectfully submitted this _____ day of _____, 20 _____

IF AN INDIVIDUAL, SIGN HERE

Signature of Bidder _____

Address _____

Telephone Number _____ Fax Number _____

Social Security Number : _____

(Signatures for a Firm, Partnership or Corporation on next page.)

PROPOSAL (continued)

IF A FIRM OR PARTNERSHIP, SIGN HERE

Signature of Bidder _____

Name of Firm or Partnership _____

Business Address _____

Telephone Number _____ Fax Number _____

Social Security or Tax ID Number : _____

Names and Addresses of Members of Firm or Partnership:

IF A CORPORATION, SIGN HERE

Name of Bidder _____

Authorized Signature _____
(name) (title)

Business Address _____

Telephone Number _____ Fax Number _____

Tax ID Number : _____

Incorporated under the Laws of the State of _____

Names and Addresses of Officers of the Corporation:

President _____

Secretary _____

Treasurer _____

_____ ss

Before me, personally appeared _____ and acknowledged that the signature to the preceding bid is his/her signature in his/her official capacity.

Date: _____

Notary Public - Signature and Seal

**ALL CORPORATIONS MUST SIGN THIS FORM
AND SUBMIT WITH THE BID PROPOSAL**

(Insert copy of that part of the records of the corporation wherein authority is given to the officer of that corporation to sign this bid on behalf of the corporation.)

(date)

The above is a true copy of the records of the _____
Corporation, which records are in my legal custody.

Officer having custody of the records

_____ ss

Before me appeared, _____,

_____ of the _____ Corporation, and
made

oath that the above statement is true.

Notary Public - Signature and Seal

NOTICE

(This Must Be Filled Out)

The full names and residences of all persons interested in this bid as principals are as follows: (In case of Corporation, include and identify President, Treasurer, Manager)

_____	_____
_____	_____
_____	_____

**ALL CONTRACTORS SHALL FILL IN THE FOLLOWING INFORMATION
BEFORE SUBMITTING BID**

	Name and Address of Supplier	Products to be Supplied
1	_____	_____
2	_____	_____
3	_____	_____
4	_____	_____
5	_____	_____
6	_____	_____

	Name and Address of Contractor	Service or Trades to be Supplied	Anticipated \$ Amount
1	_____	_____	_____
2	_____	_____	_____
3	_____	_____	_____
4	_____	_____	_____
5	_____	_____	_____
6	_____	_____	_____

BURBANK BRANCH RENOVATIONS, PORTLAND PUBLIC LIBRARY

DOCUMENT 005000 – CONTRACTING FORMS AND SUPPLEMENTS

PART 1 - GENERAL

1.1 AGREEMENT AND CONDITIONS OF THE CONTRACT

- A. See Section 005213 for the Agreement form to be executed.
- B. The Agreement is based on Agreement Between The City Of Portland And Contractor.

1.2 FORMS

- A. Use the following forms for the specified purposes unless otherwise indicated elsewhere in the Contract Documents.
- B. Preconstruction Forms:
 - 1. Form of Performance Bond and Labor and Material Bond: AIA Document A312, "Performance Bond and Payment Bond."
- C. Post-Award Certificates and Other Forms:
 - 1. Schedule of Values Form: AIA G703.
 - 2. Application for Payment Form: AIA G702 and G703.
- D. Clarification and Modification Forms:
 - 1. Supplemental Instruction Form: AIA G710.
 - 2. Construction Change Directive Form: AIA G714.
 - 3. Change Order Form: AIA G701.
- E. Closeout Forms:
 - 1. Certificate of Substantial Completion Form: AIA G704.

1.3 REFERENCE STANDARDS

- A. Agreement Between The City Of Portland And Contractor.
- B. AIA G701 - Change Order; 2001.
- C. AIA G702 - Application and Certificate for Payment; 1992.
- D. AIA G703 - Continuation Sheet; 1992.
- E. AIA G704 - Certificate of Substantial Completion; 2000.

BURBANK BRANCH RENOVATIONS, PORTLAND PUBLIC LIBRARY

- F. AIA G710 - Architect's Supplemental Instructions; 1992.
- G. AIA G714 - Construction Change Directive; 2007.

PART 2 - PRODUCTS – NOT USED

PART 3 - EXECUTION – NOT USED

END OF DOCUMENT 005000

This is a Sample Contract or Agreement ONLY; the final terms and conditions in the actual Agreement will be determined by the City's Corporation Counsel Office, and may contain additional provisions.

[SAMPLE]
AGREEMENT BETWEEN THE
CITY OF PORTLAND
AND

(CONTRACTOR)

AGREEMENT entered into this _____ day of _____, 2014 by and between the **CITY OF PORTLAND**, a body politic and corporate, (hereinafter the "**CITY**"), and _____, located at _____ (hereinafter the "**CONTRACTOR**").

WITNESSETH

WHEREAS, the **CITY** did advertise by **Bid #xx15**, entitled **Renovations to the Burbank Branch of the Portland Public Library** and

WHEREAS, the **CONTRACTOR** did, under date of September XX, 2014, submit a Bid for such work; and

WHEREAS, after due consideration of all the Proposals, the **CITY** did award the Bid to the **CONTRACTOR**;

NOW THEREFORE, in consideration of the mutual promises made by each party to the other, the parties covenant and agree as follows:

1. The **CONTRACTOR** shall furnish all labor, materials, fixtures, supplies, equipment and transportation and shall perform all work required for the construction and completion of the **Renovations to the Burbank Branch of the Portland Public Library** project in accordance with the specifications contained in the contract documents entitled Renovations at the Burbank Branch of the Portland Public Library, Bid #xx15, dated September XX, 2014 (hereinafter referred to as "Contract Documents") of which this Agreement is a part. All work shall be performed in strict conformance with the provisions of this Agreement, the Invitation for Bids, the **CONTRACTOR**'s Proposal, and any and all General and Detailed Provisions and Plans.

2. It is agreed that the amount(s) given on the Proposal Page in the **CONTRACTOR**'s Proposal Section of the Contract Documents will be used as the basis for determining the amount due under this Contract Agreement, and that the amount due under this Agreement so determined is _____ (\$_____) (hereinafter referred to as the "Contract Price"). The **CITY** will have the right to increase or decrease the amount and extent of the work by giving reasonable notice in writing to the **CONTRACTOR**.
3. **CONTRACTOR** covenants and agrees that all work performed and materials used shall be free from all defects, and that all work be performed as specified.
4. The **CITY** reserves the right to require Waivers of Lien from subcontractors and/or suppliers prior to each progress payment made to **CONTRACTOR** pursuant to the terms of this Agreement.
5. Prior to the execution of this Agreement, **CONTRACTOR** will procure and maintain Automobile coverage, Professional Liability and General Public Liability insurance coverage in the amount of not less than Four Hundred Thousand Dollars (\$400,000) per person, One Million Dollars (\$1,000,000) per occurrence for bodily injury, death and property damage, naming the **CITY** as an additional insured thereon, and also Worker's Compensation Insurance coverage. **CONTRACTOR** shall furnish and thereafter maintain certificates evidencing such coverage, which certificates shall guarantee thirty (30) days' notice to **CITY** of termination of insurance from insurance company or agent.
6. PARAGRAPH INTENTIONALLY DELETED
7. To the fullest extent permitted by law, the **CONTRACTOR** shall defend, indemnify and hold harmless the **CITY**, its officers and employees, from and against all claims, damages, losses, and expenses, just or unjust, including but not limited to the costs of defense and attorneys' fees arising out of or resulting from the performance of the Agreement, provided that any such claims, damage, loss or expense (1) is attributable to bodily injury, sickness, disease, or death, or to injury to or destruction of tangible property, including the loss of use therefrom, and (2) is caused in whole or in part by any negligent act or omission of the **CONTRACTOR**, anyone directly or indirectly employed by it, or anyone for whose act it may be liable.
8. Upon receipt of executed contracts and insurance as required, the **CITY** will promptly send an executed **CITY** contract and a "Notice to Commence Work" to the **CONTRACTOR**. The **CONTRACTOR** agrees to perform no work under this Agreement until it receives said Notice and to complete the work in the time specified; that date/time is:_____. The time set for such completion may be extended only by written consent of the Director of Recreation & Facilities Management (hereinafter referred to as the "**DIRECTOR**").
9. The **CONTRACTOR** shall perform the work to the satisfaction of the responsible **CITY** official who will have the right of inspection at all times, and whose approval and acceptance of the work will be a condition precedent to payments by the **CITY** under this Contract. **CITY** inspectors will have the authority to stop work in progress if such work is being done contrary to the plans, specifications, or engineering practice.

- 10. In the event that any dispute as to the amount, nature or scope of the work required under this Contract, the decision and judgment of the responsible **CITY** official will be final and binding.
- 11. The **CONTRACTOR** shall guarantee the work for a period of one (1) year for the faithful remedy of any defects due to faulty materials or workmanship and payment for any damage resulting therefrom.
- 12. **CONTRACTOR** shall keep accurate records of all services performed under this Agreement and shall submit such information to the **CITY** on a monthly basis. Payment for such services shall be made to **CONTRACTOR** not more than thirty (30) days after receipt of said forms and acceptance of the work by the **DIRECTOR**.
- 13. The **CITY** may terminate this Agreement for cause by written Notice to the **CONTRACTOR**. In the event of such termination, **CONTRACTOR** shall not be entitled to any further payment under this Agreement from the date of receipt of said Notice.
- 14. The **CITY** will have the right to terminate this Agreement at any time for its convenience on prior written Notice to **CONTRACTOR**. If Agreement is terminated by the **CITY** for convenience, the **CITY** will pay the **CONTRACTOR** for all work performed and all materials purchased pursuant to this Agreement prior to receipt of said Notice.

IN WITNESS WHEREOF, the said **CITY OF PORTLAND** has caused this Agreement to be signed and sealed by Sheila Hill-Christian, its Acting City Manager, thereunto duly authorized, and _____ has caused this Agreement to be signed and sealed by _____, its _____, thereunto duly authorized, the day and year first above written.

WITNESS

CITY OF PORTLAND

BY: _____

Sheila Hill-Christian
Its Acting City Manager

CONTRACTOR

By: _____

(Print or type name)

Its _____

Approved as to Form:

Approved as to funds:

Corporation Counsel's Office

Budget Office

BURBANK BRANCH RENOVATIONS, PORTLAND PUBLIC LIBRARY

SECTION 011000 - SUMMARY

PART 1 - GENERAL

1.1 RELATED DOCUMENTS

- A. Drawings and general provisions of the Contract, including General and Supplementary Conditions and other Division 01 Specification Sections, apply to this Section.

1.2 SUMMARY

- A. Section Includes:

1. Project information.
2. Work covered by Contract Documents.
3. Owner-furnished products.
4. Access to site.
5. Work restrictions.
6. Specification and drawing conventions.

- B. Related Requirements:

1. Section 015000 "Temporary Facilities and Controls" for limitations and procedures governing temporary use of Owner's facilities.

1.3 PROJECT INFORMATION

- A. Project Identification: Burbank Branch Library - Renovations.

1. Project Location: 377 Stevens Avenue, Portland, ME 04103.

- B. Owner: City of Portland, Maine.

- C. Architect Identification: The Contract Documents were prepared for Project by Scott Simons Architects, 75 York Street, Portland, ME.

- D. Construction Manager: <Insert name and contact information for Construction Manager>.

1. Construction Manager for this Project is Project's constructor. The terms "Construction Manager" and "Contractor" are synonymous.

1.4 WORK COVERED BY CONTRACT DOCUMENTS

- A. The Work of Project is defined by the Contract Documents and consists of the following:

BURBANK BRANCH RENOVATIONS, PORTLAND PUBLIC LIBRARY

1. The Work involves the renovations to the existing Burbank Branch Library at location indicated on Drawings. Work includes but is not limited, to selective demolition, site improvements, concrete foundations and slab-on-grade, alterations to existing wood structure, masonry, wood stud partitions, insulation, gypsum board walls and ceilings, resilient flooring, wood flooring, carpeting, custom cabinets and fixtures, carpentry, glass storefront system, painting, metal doors, wood doors, metal frames, door hardware, toilet accessories, signage, fire alarm systems, security systems, electrical, and heating, ventilating, and air conditioning complete and ready for use.

1.5 OWNER-FURNISHED PRODUCTS

- A. Owner will furnish products indicated. The Work includes receiving, unloading, handling, storing, protecting, and installing Owner-furnished products.
- B. Owner-Furnished Products:
 1. Bookdrop.

1.6 ACCESS TO SITE

- A. General: Contractor shall have full use of Project site for construction operations during construction period. Contractor's use of Project site is limited only by Owner's right to perform work or to retain other contractors on portions of Project.
- B. Use of Site: Limit use of Project site to areas within the Contract limits indicated. Do not disturb portions of Project site beyond areas in which the Work is indicated.
- C. Condition of Existing Building: Maintain portions of existing building affected by construction operations in a weathertight condition throughout construction period. Repair damage caused by construction operations.

1.7 WORK RESTRICTIONS

- A. Work Restrictions, General: Comply with restrictions on construction operations.
 1. Comply with limitations on use of public streets and with other requirements of authorities having jurisdiction.
- B. On-Site Work Hours: Work shall be generally performed during normal business working hours of 7:00 a.m. to 5:00 p.m., Monday through Friday, except otherwise indicated.
 1. Weekend Hours: As approved by Architect and Owner.
 2. Early Morning Hours: As approved by Architect and Owner.
 3. Hours for Utility Shutdowns: As approved by Architect and Owner.
 4. Provide 24 hour notice to Architect when performing work other than normal working hours.

- C. Existing Utility Interruptions: Do not interrupt utilities serving facilities occupied by Owner or others unless permitted under the following conditions and then only after providing temporary utility services according to requirements indicated:
 - 1. Notify Owner not less than two days in advance of proposed utility interruptions.
 - 2. Obtain Owner's written permission before proceeding with utility interruptions.
- D. Nonsmoking Building: Smoking is not permitted within the building or within 25 feet of entrances, operable windows, or outdoor-air intakes.
- E. Drugs, Alcohol, Substance Abuses, and Firearms: It is strictly prohibited to possess, use, conceal, transport, traffic any drugs, alcohol, controlled substances, or firearms on the premises of the facility. Any violations shall be grounds for dismissal and may be cause for termination of any contracts or portions thereof.

1.8 SPECIFICATION AND DRAWING CONVENTIONS

- A. Specification Format: The Specifications are organized into Divisions and Sections using the 33-division format and CSI's "2004 MasterFormat" numbering system.
 - 1. Section Identification: The Specifications use Section numbers and titles to help cross-referencing in the Contract Documents. Sections in the Project Manual are in numeric sequence; however, the sequence is incomplete because all available Section numbers are not used. Consult the table of contents at the beginning of the Project Manual to determine numbers and names of Sections in the Contract Documents.
 - 2. Division 01 General Requirements: Requirements of Sections in Division 01 apply to the Work of all Sections in the Specifications.
- B. Specification Content: The Specifications use certain conventions for the style of language and the intended meaning of certain terms, words, and phrases when used in particular situations. These conventions are as follows:
 - 1. Imperative mood and streamlined language are generally used in the Specifications. The words "shall," "shall be," or "shall comply with," depending on the context, are implied where a colon (:) is used within a sentence or phrase.
 - 2. Specification requirements are to be performed by Contractor unless specifically stated otherwise.
- C. Drawing Coordination: Requirements for materials and products identified on Drawings are described in detail in the Specifications. One or more of the following are used on Drawings to identify materials and products:
 - 1. Terminology: Materials and products are identified by the typical generic terms used in the individual Specifications Sections.
 - 2. Abbreviations: Materials and products are identified by abbreviations published as part of the U.S. National CAD Standard and scheduled on Drawings.
 - 3. Keynoting: Materials and products are identified by reference keynotes referencing Specification Section numbers found in this Project Manual.

BURBANK BRANCH RENOVATIONS, PORTLAND PUBLIC LIBRARY

PART 2 - PRODUCTS (Not Used)

PART 3 - EXECUTION (Not Used)

END OF SECTION 011000

BURBANK BRANCH RENOVATIONS, PORTLAND PUBLIC LIBRARY

SECTION 012300 - ALTERNATES

PART 1 - GENERAL

1.1 RELATED DOCUMENTS

- A. Drawings and general provisions of the Contract, including General and Supplementary Conditions and other Division 01 Specification Sections, apply to this Section.

1.2 SUMMARY

- A. Section includes administrative and procedural requirements for alternates.

1.3 DEFINITIONS

- A. Alternate: An amount proposed by bidders and stated on the Bid Form for certain work defined in the bidding requirements that may be added to or deducted from the base bid amount if Owner decides to accept a corresponding change either in the amount of construction to be completed or in the products, materials, equipment, systems, or installation methods described in the Contract Documents.
 - 1. Alternates described in this Section are part of the Work only if enumerated in the Agreement.
 - 2. The cost or credit for each alternate is the net addition to or deduction from the Contract Sum to incorporate alternate into the Work. No other adjustments are made to the Contract Sum.

1.4 PROCEDURES

- A. Coordination: Revise or adjust affected adjacent work as necessary to completely integrate work of the alternate into Project.
 - 1. Include as part of each alternate, miscellaneous devices, accessory objects, and similar items incidental to or required for a complete installation whether or not indicated as part of alternate.
- B. Notification: Immediately following award of the Contract, notify each party involved, in writing, of the status of each alternate. Indicate if alternates have been accepted, rejected, or deferred for later consideration. Include a complete description of negotiated revisions to alternates.
- C. Execute accepted alternates under the same conditions as other work of the Contract.
- D. Schedule: A schedule of alternates is included at the end of this Section. Specification Sections referenced in schedule contain requirements for materials necessary to achieve the work described under each alternate.

BURBANK BRANCH RENOVATIONS, PORTLAND PUBLIC LIBRARY

PART 2 - PRODUCTS (Not Used)

PART 3 - EXECUTION

3.1 SCHEDULE OF ALTERNATES

A. Alternate No. 1: Window Replacement.

1. Base Bid: Do not replace windows.
2. Alternate: Replace windows as indicated on the drawings and as specified in Section 085200 "Wood Windows."

END OF SECTION 012300

SECTION 012500 - SUBSTITUTION PROCEDURES

PART 1 - GENERAL

1.1 RELATED DOCUMENTS

- A. Drawings and general provisions of the Contract, including General and Supplementary Conditions and other Division 01 Specification Sections, apply to this Section.

1.2 SUMMARY

- A. Section includes administrative and procedural requirements for substitutions.
- B. Related Requirements:
 - 1. Section 012300 "Alternates" for products selected under an alternate.
 - 2. Section 016000 "Product Requirements" for requirements for submitting comparable product submittals for products by listed manufacturers.

1.3 DEFINITIONS

- A. Substitutions: Changes in products, materials, equipment, and methods of construction from those required by the Contract Documents and proposed by Contractor.
 - 1. Substitutions for Cause: Changes proposed by Contractor that are required due to changed Project conditions, such as unavailability of product, regulatory changes, or unavailability of required warranty terms.
 - 2. Substitutions for Convenience: Changes proposed by Contractor or Owner that are not required in order to meet other Project requirements but may offer advantage to Contractor or Owner.

1.4 ACTION SUBMITTALS

- A. Substitution Requests: Submit three copies of each request for consideration. Identify product or fabrication or installation method to be replaced. Include Specification Section number and title and Drawing numbers and titles.
 - 1. Documentation: Show compliance with requirements for substitutions and the following, as applicable:
 - a. Statement indicating why specified product or fabrication or installation cannot be provided, if applicable.
 - b. Coordination information, including a list of changes or revisions needed to other parts of the Work and to construction performed by Owner and separate contractors, that will be necessary to accommodate proposed substitution.

- c. Detailed comparison of significant qualities of proposed substitution with those of the Work specified. Include annotated copy of applicable Specification Section. Significant qualities may include attributes such as performance, weight, size, durability, visual effect, sustainable design characteristics, warranties, and specific features and requirements indicated. Indicate deviations, if any, from the Work specified.
 - d. Product Data, including drawings and descriptions of products and fabrication and installation procedures.
 - e. Samples, where applicable or requested.
 - f. Certificates and qualification data, where applicable or requested.
 - g. List of similar installations for completed projects with project names and addresses and names and addresses of architects and owners.
 - h. Material test reports from a qualified testing agency indicating and interpreting test results for compliance with requirements indicated.
 - i. Research reports evidencing compliance with building code in effect for Project, from ICC-ES.
 - j. Detailed comparison of Contractor's construction schedule using proposed substitution with products specified for the Work, including effect on the overall Contract Time. If specified product or method of construction cannot be provided within the Contract Time, include letter from manufacturer, on manufacturer's letterhead, stating date of receipt of purchase order, lack of availability, or delays in delivery.
 - k. Cost information, including a proposal of change, if any, in the Contract Sum.
 - l. Contractor's certification that proposed substitution complies with requirements in the Contract Documents except as indicated in substitution request, is compatible with related materials, and is appropriate for applications indicated.
 - m. Contractor's waiver of rights to additional payment or time that may subsequently become necessary because of failure of proposed substitution to produce indicated results.
2. Architect's Action: If necessary, Architect will request additional information or documentation for evaluation within three days of receipt of a request for substitution. Architect will notify Contractor of acceptance or rejection of proposed substitution by addendum.
- a. Use product specified if Architect cannot make a decision on use of a proposed substitution within time allocated or notification is not made by addendum.

1.5 QUALITY ASSURANCE

- A. Compatibility of Substitutions: Investigate and document compatibility of proposed substitution with related products and materials. Engage a qualified testing agency to perform compatibility tests recommended by manufacturers.
- B. Products with asbestos: Asbestos containing materials are not to be purchased or installed in this project.

1.6 PROCEDURES

- A. Coordination: Revise or adjust affected work as necessary to integrate work of the approved substitutions.

PART 2 - PRODUCTS

2.1 SUBSTITUTIONS

- A. Substitutions for Cause: Submit requests for substitution immediately on discovery of need for change, but not later than 15 days prior to time required for preparation and review of related submittals.

- 1. Conditions: Architect will consider Contractor's request for substitution when the following conditions are satisfied. If the following conditions are not satisfied, Architect will return requests without action, except to record noncompliance with these requirements:

- a. Requested substitution is consistent with the Contract Documents and will produce indicated results.
- b. Substitution request is fully documented and properly submitted.
- c. Requested substitution will not adversely affect Contractor's construction schedule.
- d. Requested substitution has received necessary approvals of authorities having jurisdiction.
- e. Requested substitution is compatible with other portions of the Work.
- f. Requested substitution has been coordinated with other portions of the Work.
- g. Requested substitution provides specified warranty.
- h. If requested substitution involves more than one contractor, requested substitution has been coordinated with other portions of the Work, is uniform and consistent, is compatible with other products, and is acceptable to all contractors involved.

- B. Substitutions for Convenience: Architect will consider requests for substitution if received within 60 days after commencement of the Work. Requests received after that time may be considered or rejected at discretion of Architect.

- 1. Conditions: Architect will consider Contractor's request for substitution when the following conditions are satisfied. If the following conditions are not satisfied, Architect will return requests without action, except to record noncompliance with these requirements:

- a. Requested substitution offers Owner a substantial advantage in cost, time, energy conservation, or other considerations, after deducting additional responsibilities Owner must assume. Owner's additional responsibilities may include compensation to Architect for redesign and evaluation services, increased cost of other construction by Owner, and similar considerations.
- b. Requested substitution does not require extensive revisions to the Contract Documents.
- c. Requested substitution is consistent with the Contract Documents and will produce indicated results.

BURBANK BRANCH RENOVATIONS, PORTLAND PUBLIC LIBRARY

- d. Substitution request is fully documented and properly submitted.
- e. Requested substitution will not adversely affect Contractor's construction schedule.
- f. Requested substitution has received necessary approvals of authorities having jurisdiction.
- g. Requested substitution is compatible with other portions of the Work.
- h. Requested substitution has been coordinated with other portions of the Work.
- i. Requested substitution provides specified warranty.
- j. If requested substitution involves more than one contractor, requested substitution has been coordinated with other portions of the Work, is uniform and consistent, is compatible with other products, and is acceptable to all contractors involved.

PART 3 - EXECUTION (Not Used)

END OF SECTION 012500

SECTION 012600 - CONTRACT MODIFICATION PROCEDURES

PART 1 - GENERAL

1.1 RELATED DOCUMENTS

- A. Drawings and general provisions of the Contract, including General and Supplementary Conditions and other Division 01 Specification Sections, apply to this Section.

1.2 SUMMARY

- A. Section includes administrative and procedural requirements for handling and processing Contract modifications.
- B. Related Requirements:
 - 1. Section 012500 "Substitution Procedures" for administrative procedures for handling requests for substitutions made after the Contract award.

1.3 MINOR CHANGES IN THE WORK

- A. Architect will issue supplemental instructions authorizing minor changes in the Work, not involving adjustment to the Contract Sum or the Contract Time, on AIA Document G710, "Architect's Supplemental Instructions"

1.4 PROPOSAL REQUESTS

- A. Owner-Initiated Proposal Requests: Architect will issue a detailed description of proposed changes in the Work that may require adjustment to the Contract Sum or the Contract Time. If necessary, the description will include supplemental or revised Drawings and Specifications.
 - 1. Work Change Proposal Requests issued by Architect are not instructions either to stop work in progress or to execute the proposed change.
 - 2. Within 20 days, when not otherwise specified, after receipt of Proposal Request, submit a quotation estimating cost adjustments to the Contract Sum and the Contract Time necessary to execute the change.
 - a. Include a list of quantities of products required or eliminated and unit costs, with total amount of purchases and credits to be made. If requested, furnish survey data to substantiate quantities.
 - b. Indicate applicable bonds, insurance, taxes, delivery charges, equipment rental, and amounts of trade discounts.
 - c. Include costs of labor and supervision directly attributable to the change.
 - d. Include quotes on supplier's and subcontractor's letterhead for the requested change.

BURBANK BRANCH RENOVATIONS, PORTLAND PUBLIC LIBRARY

- e. Include an updated Contractor's construction schedule that indicates the effect of the change, including, but not limited to, changes in activity duration, start and finish times, and activity relationship. Use available total float before requesting an extension of the Contract Time.
- B. Contractor-Initiated Proposals: If latent or changed conditions require modifications to the Contract, Contractor may initiate a claim by submitting a request for a change to Architect.
1. Include a statement outlining reasons for the change and the effect of the change on the Work. Provide a complete description of the proposed change. Indicate the effect of the proposed change on the Contract Sum and the Contract Time.
 2. Include a list of quantities of products required or eliminated and unit costs, with total amount of purchases and credits to be made. If requested, furnish survey data to substantiate quantities.
 3. Indicate applicable bonds, insurance, taxes, delivery charges, equipment rental, and amounts of trade discounts.
 4. Include costs of labor and supervision directly attributable to the change.
 5. Include an updated Contractor's construction schedule that indicates the effect of the change, including, but not limited to, changes in activity duration, start and finish times, and activity relationship. Use available total float before requesting an extension of the Contract Time.
 6. Comply with requirements in Section 012500 "Substitution Procedures" if the proposed change requires substitution of one product or system for product or system specified.
 7. Proposal Request Form: Use form acceptable to Architect.
- C. Proposal Request Form: Use AIA Document G709 for Proposal Requests.

1.5 CHANGE ORDER PROCEDURES

- A. On Owner's approval of a Work Changes Proposal Request, Architect will issue a Change Order for signatures of Owner and Contractor on AIA Document G701.

1.6 CONSTRUCTION CHANGE DIRECTIVE

- A. Construction Change Directive: Architect may issue a Construction Change Directive on AIA Document G714. Construction Change Directive instructs Contractor to proceed with a change in the Work, for subsequent inclusion in a Change Order.
1. Construction Change Directive contains a complete description of change in the Work. It also designates method to be followed to determine change in the Contract Sum or the Contract Time.
- B. Documentation: Maintain detailed records on a time and material basis of work required by the Construction Change Directive.
1. After completion of change, submit an itemized account and supporting data necessary to substantiate cost and time adjustments to the Contract.

BURBANK BRANCH RENOVATIONS, PORTLAND PUBLIC LIBRARY

PART 2 - PRODUCTS (Not Used)

PART 3 - EXECUTION (Not Used)

END OF SECTION 012600

SECTION 012900 - PAYMENT PROCEDURES

PART 1 - GENERAL

1.1 RELATED DOCUMENTS

- A. Drawings and general provisions of the Contract, including General and Supplementary Conditions and other Division 01 Specification Sections, apply to this Section.

1.2 SUMMARY

- A. Section includes administrative and procedural requirements necessary to prepare and process Applications for Payment.
- B. Related Requirements:
 - 1. Section 012600 "Contract Modification Procedures" for administrative procedures for handling changes to the Contract.
 - 2. Section 013200 "Construction Progress Documentation" for administrative requirements governing the preparation and submittal of the Contractor's construction schedule.

1.3 DEFINITIONS

- A. Schedule of Values: A statement furnished by Contractor allocating portions of the Contract Sum to various portions of the Work and used as the basis for reviewing Contractor's Applications for Payment.

1.4 SCHEDULE OF VALUES

- A. Coordination: Coordinate preparation of the schedule of values with preparation of Contractor's construction schedule.
 - 1. Coordinate line items in the schedule of values with other required administrative forms and schedules, including the following:
 - a. Application for Payment forms with continuation sheets.
 - b. Submittal schedule.
 - c. Items required to be indicated as separate activities in Contractor's construction schedule.
 - 2. Submit the schedule of values to Architect at earliest possible date, but no later than seven days before the date scheduled for submittal of initial Applications for Payment.
 - 3. Subschedules for Separate Elements of Work: Where the Contractor's construction schedule defines separate elements of the Work, provide subschedules showing values coordinated with each element.

BURBANK BRANCH RENOVATIONS, PORTLAND PUBLIC LIBRARY

- B. Format and Content: Use Project Manual table of contents as a guide to establish line items for the schedule of values. Provide at least one line item for each Specification Section.
1. Identification: Include the following Project identification on the schedule of values:
 - a. Project name and location.
 - b. Name of Architect.
 - c. Architect's project number.
 - d. Contractor's name and address.
 - e. Date of submittal.
 2. Arrange schedule of values consistent with format of AIA Document G703.
 3. Arrange the schedule of values in tabular form with separate columns to indicate the following for each item listed:
 - a. Related Specification Section or Division.
 - b. Description of the Work.
 - c. Name of subcontractor.
 - d. Name of manufacturer or fabricator.
 - e. Name of supplier.
 - f. Change Orders (numbers) that affect value.
 - g. Dollar value of the following, as a percentage of the Contract Sum to nearest one-hundredth percent, adjusted to total 100 percent.
 - 1) Labor.
 - 2) Materials.
 - 3) Equipment.
 4. Provide a breakdown of the Contract Sum in enough detail to facilitate continued evaluation of Applications for Payment and progress reports. Coordinate with Project Manual table of contents. Provide multiple line items for principal subcontract amounts in excess of five percent of the Contract Sum.
 - a. Include separate line items under Contractor and principal subcontracts for Project closeout requirements in an amount totaling five percent of the Contract Sum and subcontract amount.
 5. Round amounts to nearest whole dollar; total shall equal the Contract Sum.
 6. Provide a separate line item in the schedule of values for each part of the Work where Applications for Payment may include materials or equipment purchased or fabricated and stored, but not yet installed.
 - a. Differentiate between items stored on-site and items stored off-site. If required, include evidence of insurance.
 7. Provide separate line items in the schedule of values for initial cost of materials, for each subsequent stage of completion, and for total installed value of that part of the Work.
 8. Each item in the schedule of values and Applications for Payment shall be complete. Include total cost and proportionate share of general overhead and profit for each item.

BURBANK BRANCH RENOVATIONS, PORTLAND PUBLIC LIBRARY

- a. Temporary facilities and other major cost items that are not direct cost of actual work-in-place may be shown either as separate line items in the schedule of values or distributed as general overhead expense, at Contractor's option.
9. Schedule Updating: Update and resubmit the schedule of values before the next Applications for Payment when Change Orders or Construction Change Directives result in a change in the Contract Sum.
- C. Draw-Down Schedule: The Contractor shall furnish to the Architect, at the beginning of the project, an expected monthly requisition estimate for the Owner's use in planning funding.

1.5 APPLICATIONS FOR PAYMENT

- A. Each Application for Payment following the initial Application for Payment shall be consistent with previous applications and payments as certified by Architect and paid for by Owner.
 1. Initial Application for Payment, Application for Payment at time of Substantial Completion, and final Application for Payment involve additional requirements.
- B. Payment Application Times: The date for each progress payment is indicated in the Agreement between Owner and Contractor. The period of construction work covered by each Application for Payment is the period indicated in the Agreement.
 1. Submit draft copy of Application for Payment seven days prior to due date for review by Architect.
- C. Application for Payment Forms: Use AIA Document G702 and AIA Document G703 as form for Applications for Payment.
- D. Application Preparation: Complete every entry on form. Notarize and execute by a person authorized to sign legal documents on behalf of Contractor. Architect will return incomplete applications without action.
 1. Entries shall match data on the schedule of values and Contractor's construction schedule. Use updated schedules if revisions were made.
 2. Include amounts for work completed following previous Application for Payment, whether or not payment has been received. Include only amounts for work completed at time of Application for Payment.
 3. Include amounts of Change Orders and Construction Change Directives issued before last day of construction period covered by application.
- E. Stored Materials: Include in Application for Payment amounts applied for materials or equipment purchased or fabricated and stored, but not yet installed. Differentiate between items stored on-site and items stored off-site.
 1. Provide certificate of insurance, evidence of transfer of title to Owner, and consent of surety to payment, for stored materials.
 2. Provide supporting documentation that verifies amount requested, such as paid invoices. Match amount requested with amounts indicated on documentation; do not include overhead and profit on stored materials.

BURBANK BRANCH RENOVATIONS, PORTLAND PUBLIC LIBRARY

3. Provide summary documentation for stored materials indicating the following:
 - a. Value of materials previously stored and remaining stored as of date of previous Applications for Payment.
 - b. Value of previously stored materials put in place after date of previous Application for Payment and on or before date of current Application for Payment.
 - c. Value of materials stored since date of previous Application for Payment and remaining stored as of date of current Application for Payment.

- F. Transmittal: Submit three signed and notarized original copies of each Application for Payment to Architect by a method ensuring receipt within 24 hours. One copy shall include waivers of lien and similar attachments if required.
 1. Transmit each copy with a transmittal form listing attachments and recording appropriate information about application.

- G. Waivers of Mechanic's Lien: With each Application for Payment, submit waivers of mechanic's liens from subcontractors, sub-subcontractors, and suppliers for construction period covered by the previous application.
 1. Submit partial waivers on each item for amount requested in previous application, after deduction for retainage, on each item.
 2. When an application shows completion of an item, submit conditional final or full waivers.
 3. The list of subcontractors, principal suppliers and fabricators shall be used to designate which entities involved in the Work must submit waivers. The list shall be approved by the Owner.
 4. Submit final Application for Payment with or preceded by conditional final waivers from every entity involved with performance of the Work covered by the application who is lawfully entitled to a lien.
 5. Waiver Forms: Submit executed waivers of lien on forms, acceptable to Owner.

- H. Record Drawing Updates: With each Application of Payment, record documents shall be maintained and current for all trades, available for viewing at a central location.

- I. Initial Application for Payment: Administrative actions and submittals that must precede or coincide with submittal of first Application for Payment include the following:
 1. List of subcontractors.
 2. Schedule of values.
 3. Contractor's construction schedule (preliminary if not final).
 4. Combined Contractor's construction schedule (preliminary if not final) incorporating Work of multiple contracts, with indication of acceptance of schedule by each Contractor.
 5. Products list (preliminary if not final).
 6. Submittal schedule (preliminary if not final).
 7. List of Contractor's staff assignments.
 8. List of Contractor's principal consultants.
 9. Copies of building permits and other required permits.
 10. Copies of authorizations and licenses from authorities having jurisdiction for performance of the Work.
 11. Initial progress report.

BURBANK BRANCH RENOVATIONS, PORTLAND PUBLIC LIBRARY

12. Report of preconstruction conference.
 13. Certificates of insurance and insurance policies.
 14. Performance and payment bonds.
- J. Progress Applications for Payment: Administrative actions and submittals that must precede or coincide with submittal of progress Applications for Payment include the following:
1. Contractor's Construction Schedule update.
 2. Submittals for Work being requisitioned for are complete and approved.
 3. Submit list of completed tests, checklists, commissioning, reports, and similar requirements for the work are submitted and in compliance with the Contract Documents.
 4. Minutes of previous month's progress meeting have been distributed.
 5. Record drawings and documents are current.
- K. Application for Payment at Substantial Completion: After Architect issues the Certificate of Substantial Completion, submit an Application for Payment showing 100 percent completion for portion of the Work claimed as substantially complete.
1. Include documentation supporting claim that the Work is substantially complete and a statement showing an accounting of changes to the Contract Sum.
 2. This application shall reflect Certificate(s) of Substantial Completion issued previously for Owner occupancy of designated portions of the Work.
- L. Final Payment Application: After completing Project closeout requirements, submit final Application for Payment with releases and supporting documentation not previously submitted and accepted, including, but not limited, to the following:
1. Evidence of completion of Project closeout requirements.
 2. Final submittal of record documents and operation, maintenance data and demonstration and training.
 3. Insurance certificates for products and completed operations where required and proof that taxes, fees, and similar obligations were paid.
 4. Updated final statement, accounting for final changes to the Contract Sum.
 5. Waiver Forms: Submit waivers of lien on forms, and executed in a manner, acceptable to the Owner.
 6. Evidence that claims have been settled.
 7. Final meter readings for utilities, a measured record of stored fuel, and similar data as of date of Substantial Completion or when Owner took possession of and assumed responsibility for corresponding elements of the Work.
 8. Final liquidated damages settlement statement, if applicable.

PART 2 - PRODUCTS (Not Used)

PART 3 - EXECUTION (Not Used)

END OF SECTION 012900

SECTION 013100 - PROJECT MANAGEMENT AND COORDINATION

PART 1 - GENERAL

1.1 RELATED DOCUMENTS

- A. Drawings and general provisions of the Contract, including General and Supplementary Conditions and other Division 01 Specification Sections, apply to this Section.

1.2 SUMMARY

- A. Section includes administrative provisions for coordinating construction operations on Project including, but not limited to, the following:
 - 1. General coordination procedures.
 - 2. Requests for Information (RFIs).
 - 3. Project meetings.
- B. Each contractor shall participate in coordination requirements. Certain areas of responsibility are assigned to a specific contractor.
- C. Related Requirements:
 - 1. Section 013200 "Construction Progress Documentation" for preparing and submitting Contractor's construction schedule.
 - 2. Section 017300 "Execution" for procedures for coordinating general installation and field-engineering services, including establishment of benchmarks and control points.
 - 3. Section 017700 "Closeout Procedures" for coordinating closeout of the Contract.

1.3 DEFINITIONS

- A. RFI: Request from Owner, Architect, or Contractor seeking information required by or clarifications of the Contract Documents.

1.4 INFORMATIONAL SUBMITTALS

- A. Subcontract List: Prepare a written summary identifying individuals or firms proposed for each portion of the Work, including those who are to furnish products or equipment fabricated to a special design. Include the following information in tabular form:
 - 1. Name, address, and telephone number of entity performing subcontract or supplying products.
 - 2. Number and title of related Specification Section(s) covered by subcontract.
 - 3. Drawing number and detail references, as appropriate, covered by subcontract.

BURBANK BRANCH RENOVATIONS, PORTLAND PUBLIC LIBRARY

- B. Key Personnel Names: Within 15 days of starting construction operations, submit a list of key personnel assignments, including superintendent and other personnel in attendance at Project site. Identify individuals and their duties and responsibilities; list addresses and telephone numbers, including home, office, and cellular telephone numbers and e-mail addresses. Provide names, addresses, and telephone numbers of individuals assigned as alternates in the absence of individuals assigned to Project.
 - 1. Post copies of list in project meeting room, in temporary field office, and by each temporary telephone. Keep list current at all times.

1.5 GENERAL COORDINATION PROCEDURES

- A. Coordination: Coordinate construction operations included in different Sections of the Specifications to ensure efficient and orderly installation of each part of the Work. Coordinate construction operations, included in different Sections that depend on each other for proper installation, connection, and operation.
 - 1. Schedule construction operations in sequence required to obtain the best results where installation of one part of the Work depends on installation of other components, before or after its own installation.
 - 2. Coordinate installation of different components to ensure maximum performance and accessibility for required maintenance, service, and repair.
 - 3. Make adequate provisions to accommodate items scheduled for later installation.
 - 4. Where availability of space is limited, coordinate installation of different components to ensure maximum performance and accessibility for required maintenance, service, and repair of all components, including mechanical and electrical. Coordinate location of pipes, conduits, ducts and similar items in confined areas to assure proper fit and access. Contractor is responsible for handling interferences created by the work of subcontractors (example, sprinkler pipe interfering with installation of duct work; duct work interfering with installation of light fixtures, overhead construction interfering with installation of finish ceilings at proper height).
 - 5. Coordinate the work to provide smoke and fire seals for component interfaces and penetrations of smoke walls and fire rated construction.
- B. Prepare memoranda for distribution to each party involved, outlining special procedures required for coordination. Include such items as required notices, reports, and list of attendees at meetings.
 - 1. Prepare similar memoranda for Owner and separate contractors if coordination of their Work is required.
- C. Administrative Procedures: Coordinate scheduling and timing of required administrative procedures with other construction activities and activities of other contractors to avoid conflicts and to ensure orderly progress of the Work. Such administrative activities include, but are not limited to, the following:
 - 1. Preparation of Contractor's construction schedule.
 - 2. Preparation of the schedule of values.
 - 3. Installation and removal of temporary facilities and controls.
 - 4. Delivery and processing of submittals.

5. Progress meetings.
6. Preinstallation conferences.
7. Project closeout activities.
8. Startup and adjustment of systems.

D. Conservation: Coordinate construction activities to ensure that operations are carried out with consideration given to conservation of energy, water, and materials. Coordinate use of temporary utilities to minimize waste.

1. Salvage materials and equipment involved in performance of, but not actually incorporated into, the Work. See other Sections for disposition of salvaged materials that are designated as Owner's property.

1.6 REQUESTS FOR INFORMATION (RFIs)

A. General: Immediately on discovery of the need for additional information or interpretation of the Contract Documents, Contractor shall prepare and submit an RFI in the form specified.

1. Architect will return RFIs submitted to Architect by other entities controlled by Contractor with no response.
2. Coordinate and submit RFIs in a prompt manner so as to avoid delays in Contractor's work or work of subcontractors.

B. Content of the RFI: Include a detailed, legible description of item needing information or interpretation and the following:

1. Project name.
2. Project number.
3. Date.
4. Name of Contractor.
5. Name of Architect.
6. RFI number, numbered sequentially.
7. RFI subject.
8. Specification Section number and title and related paragraphs, as appropriate.
9. Drawing number and detail references, as appropriate.
10. Field dimensions and conditions, as appropriate.
11. Contractor's suggested resolution. If Contractor's suggested resolution impacts the Contract Time or the Contract Sum, Contractor shall state impact in the RFI.
12. Contractor's signature.
13. Attachments: Include sketches, descriptions, measurements, photos, Product Data, Shop Drawings, coordination drawings, and other information necessary to fully describe items needing interpretation.
 - a. Include dimensions, thicknesses, structural grid references, and details of affected materials, assemblies, and attachments on attached sketches.

C. RFI Forms: Software-generated form with substantially the same content as indicated above, acceptable to Architect.

1. Attachments shall be electronic files in Adobe Acrobat PDF format.

BURBANK BRANCH RENOVATIONS, PORTLAND PUBLIC LIBRARY

- D. Architect's Action: Architect will review each RFI, determine action required, and respond. RFIs received by Architect after 1:00 p.m. will be considered as received the following working day.
1. The following Contractor-generated RFIs will be returned without action:
 - a. Requests for approval of submittals.
 - b. Requests for approval of substitutions.
 - c. Requests for approval of Contractor's means and methods.
 - d. Requests for coordination information already indicated in the Contract Documents.
 - e. Requests for adjustments in the Contract Time or the Contract Sum.
 - f. Requests for interpretation of Architect's actions on submittals.
 - g. Incomplete RFIs or inaccurately prepared RFIs.
 2. Architect's action may include a request for additional information, in which case Architect's time for response will date from time of receipt of additional information.
 3. Architect's action on RFIs that may result in a change to the Contract Time or the Contract Sum may be eligible for Contractor to submit Change Proposal according to Section 012600 "Contract Modification Procedures."
 - a. If Contractor believes the RFI response warrants change in the Contract Time or the Contract Sum, notify Architect in writing within 10 days of receipt of the RFI response.
- E. RFI Log: Prepare, maintain, and submit a tabular log of RFIs organized by the RFI number. Submit log weekly. Software log with not less than the following:
1. Project name.
 2. Name and address of Contractor.
 3. Name and address of Architect.
 4. RFI number including RFIs that were returned without action or withdrawn.
 5. RFI description.
 6. Date the RFI was submitted.
 7. Date Architect's response was received.
- F. On receipt of Architect's action, update the RFI log and immediately distribute the RFI response to affected parties. Review response and notify Architect within seven days if Contractor disagrees with response.
1. Identification of related Minor Change in the Work, Construction Change Directive, and Proposal Request, as appropriate.
 2. Identification of related Field Order, Work Change Directive, and Proposal Request, as appropriate.

1.7 PROJECT MEETINGS

- A. General: Schedule and conduct meetings and conferences at Project site unless otherwise indicated.

BURBANK BRANCH RENOVATIONS, PORTLAND PUBLIC LIBRARY

1. Attendees: Inform participants and others involved, and individuals whose presence is required, of date and time of each meeting. Notify Owner and Architect of scheduled meeting dates and times.
 2. Agenda: Prepare the meeting agenda. Distribute the agenda to all invited attendees.
 3. Minutes: Entity responsible for conducting meeting will record significant discussions and agreements achieved. Distribute the meeting minutes to everyone concerned, including Owner and Architect, within three days of the meeting.
- B. Preconstruction Conference: Schedule and conduct a preconstruction conference before starting construction, at a time convenient to Owner and Architect, but no later than 15 days after execution of the Agreement.
1. Conduct the conference to review responsibilities and personnel assignments.
 2. Attendees: Authorized representatives of Owner, Architect, and their consultants; Contractor and its superintendent; major subcontractors; suppliers; and other concerned parties shall attend the conference. Participants at the conference shall be familiar with Project and authorized to conclude matters relating to the Work.
 3. Agenda: Discuss items of significance that could affect progress, including the following:
 - a. Tentative construction schedule.
 - b. Critical work sequencing and long-lead items.
 - c. Designation of key personnel and their duties.
 - d. Lines of communications.
 - e. Procedures for processing field decisions and Change Orders.
 - f. Procedures for RFIs.
 - g. Procedures for testing and inspecting.
 - h. Procedures for processing Applications for Payment.
 - i. Distribution of the Contract Documents.
 - j. Submittal procedures.
 - k. Preparation of record documents.
 - l. Use of the premises and existing building.
 - m. Work restrictions.
 - n. Working hours.
 - o. Owner's occupancy requirements.
 - p. Responsibility for temporary facilities and controls.
 - q. Procedures for moisture and mold control.
 - r. Procedures for disruptions and shutdowns.
 - s. Construction waste management and recycling.
 - t. Parking availability.
 - u. Office, work, and storage areas.
 - v. Equipment deliveries and priorities.
 - w. First aid.
 - x. Security.
 - y. Progress cleaning.
 4. Minutes: Entity responsible for conducting meeting will record and distribute meeting minutes.
- C. Preinstallation Conferences: Conduct a preinstallation conference at Project site before each construction activity that requires coordination with other construction.

BURBANK BRANCH RENOVATIONS, PORTLAND PUBLIC LIBRARY

1. Attendees: Installer and representatives of manufacturers and fabricators involved in or affected by the installation and its coordination or integration with other materials and installations that have preceded or will follow, shall attend the meeting. Advise Architect of scheduled meeting dates.
 2. Agenda: Review progress of other construction activities and preparations for the particular activity under consideration, including requirements for the following:
 - a. Contract Documents.
 - b. Options.
 - c. Related RFIs.
 - d. Related Change Orders.
 - e. Purchases.
 - f. Deliveries.
 - g. Submittals.
 - h. Review of mockups.
 - i. Possible conflicts.
 - j. Compatibility requirements.
 - k. Time schedules.
 - l. Weather limitations.
 - m. Manufacturer's written instructions.
 - n. Warranty requirements.
 - o. Compatibility of materials.
 - p. Acceptability of substrates.
 - q. Temporary facilities and controls.
 - r. Space and access limitations.
 - s. Regulations of authorities having jurisdiction.
 - t. Testing and inspecting requirements.
 - u. Installation procedures.
 - v. Coordination with other work.
 - w. Required performance results.
 - x. Protection of adjacent work.
 - y. Protection of construction and personnel.
 3. Record significant conference discussions, agreements, and disagreements, including required corrective measures and actions.
 4. Reporting: Distribute minutes of the meeting to each party present and to other parties requiring information.
 5. Do not proceed with installation if the conference cannot be successfully concluded. Initiate whatever actions are necessary to resolve impediments to performance of the Work and reconvene the conference at earliest feasible date.
- D. Project Closeout Conference: Schedule and conduct a project closeout conference, at a time convenient to Owner and Architect, but no later than 60 days prior to the scheduled date of Substantial Completion.
1. Conduct the conference to review requirements and responsibilities related to Project closeout.
 2. Attendees: Authorized representatives of Owner, Architect, and their consultants; Contractor and its superintendent; major subcontractors; suppliers; and other concerned parties shall attend the meeting. Participants at the meeting shall be familiar with Project and authorized to conclude matters relating to the Work.

3. Agenda: Discuss items of significance that could affect or delay Project closeout, including the following:
 - a. Preparation of record documents.
 - b. Procedures required prior to inspection for Substantial Completion and for final inspection for acceptance.
 - c. Submittal of written warranties.
 - d. Requirements for preparing operations and maintenance data.
 - e. Requirements for delivery of material samples, attic stock, and spare parts.
 - f. Requirements for demonstration and training.
 - g. Preparation of Contractor's punch list.
 - h. Procedures for processing Applications for Payment at Substantial Completion and for final payment.
 - i. Submittal procedures.
 - j. Coordination of separate contracts.
 - k. Owner's partial occupancy requirements.
 - l. Installation of Owner's furniture, fixtures, and equipment.
 - m. Responsibility for removing temporary facilities and controls.
 4. Minutes: Entity conducting meeting will record and distribute meeting minutes.
- E. Progress Meetings: Conduct progress meetings at monthly intervals.
1. Coordinate dates of meetings with preparation of payment requests.
 2. Attendees: In addition to representatives of Owner and Architect, each contractor, subcontractor, supplier, and other entity concerned with current progress or involved in planning, coordination, or performance of future activities shall be represented at these meetings. All participants at the meeting shall be familiar with Project and authorized to conclude matters relating to the Work.
 3. Agenda: Review and correct or approve minutes of previous progress meeting. Review other items of significance that could affect progress. Include topics for discussion as appropriate to status of Project.
 - a. Contractor's Construction Schedule: Review progress since the last meeting. Determine whether each activity is on time, ahead of schedule, or behind schedule, in relation to Contractor's construction schedule. Determine how construction behind schedule will be expedited; secure commitments from parties involved to do so. Discuss whether schedule revisions are required to ensure that current and subsequent activities will be completed within the Contract Time.
 - 1) Review schedule for next period.
 - b. Application for Payment: Contractor shall bring copy of Application for Payment to meeting. Review Application for Payment and required attachments, including record drawing and documents status, waivers of mechanic's liens, list of completed tests, checklists, commissioning, reports, and similar requirements for the work are submitted and in compliance with the Contract Documents.
 - c. Review present and future needs of each entity present, including the following:
 - 1) Interface requirements.
 - 2) Sequence of operations.

BURBANK BRANCH RENOVATIONS, PORTLAND PUBLIC LIBRARY

- 3) Status of submittals.
 - 4) Deliveries.
 - 5) Off-site fabrication.
 - 6) Access.
 - 7) Site utilization.
 - 8) Temporary facilities and controls.
 - 9) Progress cleaning.
 - 10) Quality and work standards.
 - 11) Status of correction of deficient items.
 - 12) Field observations.
 - 13) Status of RFIs.
 - 14) Status of proposal requests.
 - 15) Pending changes.
 - 16) Status of Change Orders.
 - 17) Pending claims and disputes.
 - 18) Documentation of information for payment requests.
4. Minutes: Entity responsible for conducting the meeting will record and distribute the meeting minutes to each party present and to parties requiring information.
- a. Schedule Updating: Revise Contractor's construction schedule after each progress meeting where revisions to the schedule have been made or recognized. Issue revised schedule concurrently with the report of each meeting.
- F. Coordination Meetings: Conduct Project coordination meetings at regular intervals. Project coordination meetings are in addition to specific meetings held for other purposes, such as progress meetings and preinstallation conferences.
1. Attendees: In addition to representatives of Owner and Architect, each contractor, subcontractor, supplier, and other entity concerned with current progress or involved in planning, coordination, or performance of future activities shall be represented at these meetings. All participants at the meetings shall be familiar with Project and authorized to conclude matters relating to the Work.
 2. Agenda: Review and correct or approve minutes of the previous coordination meeting. Review other items of significance that could affect progress. Include topics for discussion as appropriate to status of Project.
 - a. Combined Contractor's Construction Schedule: Review progress since the last coordination meeting. Determine whether each contract is on time, ahead of schedule, or behind schedule, in relation to combined Contractor's construction schedule. Determine how construction behind schedule will be expedited; secure commitments from parties involved to do so. Discuss whether schedule revisions are required to ensure that current and subsequent activities will be completed within the Contract Time.
 - b. Schedule Updating: Revise combined Contractor's construction schedule after each coordination meeting where revisions to the schedule have been made or recognized. Issue revised schedule concurrently with report of each meeting.
 - c. Review present and future needs of each contractor present, including the following:
 - 1) Interface requirements.

BURBANK BRANCH RENOVATIONS, PORTLAND PUBLIC LIBRARY

- 2) Sequence of operations.
 - 3) Status of submittals.
 - 4) Deliveries.
 - 5) Off-site fabrication.
 - 6) Access.
 - 7) Site utilization.
 - 8) Temporary facilities and controls.
 - 9) Work hours.
 - 10) Hazards and risks.
 - 11) Progress cleaning.
 - 12) Quality and work standards.
 - 13) Change Orders.
3. Conduct coordination meetings with the mechanical, plumbing, sprinkler and electrical trades. Before the trades start work in an area of the building, make field measurements, review structural clearances and locations of ducts, pipes, conduits, light fixtures, equipment and other items that affect location and proper fit. Prepare coordination sketches to maximize utilization of space for efficient installation of different components. Verify depths and clearances before fabrication of ductwork.
 4. Reporting: Record meeting results and distribute copies to everyone in attendance and to others affected by decisions or actions resulting from each meeting.

PART 2 - PRODUCTS (Not Used)

PART 3 - EXECUTION (Not Used)

END OF SECTION 013100

SECTION 013200 - CONSTRUCTION PROGRESS DOCUMENTATION

PART 1 - GENERAL

1.1 RELATED DOCUMENTS

- A. Drawings and general provisions of the Contract, including General and Supplementary Conditions and other Division 01 Specification Sections, apply to this Section.

1.2 SUMMARY

- A. Section includes administrative and procedural requirements for documenting the progress of construction during performance of the Work, including the following:
 - 1. Startup construction schedule.
 - 2. Contractor's construction schedule.
 - 3. Construction schedule updating reports.
 - 4. Daily construction reports.
 - 5. Material location reports.
 - 6. Site condition reports.
 - 7. Special reports.
- B. Related Requirements:
 - 1. Section 013300 "Submittal Procedures" for submitting schedules and reports.
 - 2. Section 014000 "Quality Requirements" for submitting a schedule of tests and inspections.

1.3 DEFINITIONS

- A. Activity: A discrete part of a project that can be identified for planning, scheduling, monitoring, and controlling the construction project. Activities included in a construction schedule consume time and resources.
 - 1. Critical Activity: An activity on the critical path that must start and finish on the planned early start and finish times.
 - 2. Predecessor Activity: An activity that precedes another activity in the network.
 - 3. Successor Activity: An activity that follows another activity in the network.
- B. Critical Path: The longest connected chain of interdependent activities through the network schedule that establishes the minimum overall Project duration and contains no float.
- C. Event: The starting or ending point of an activity.
- D. Float: The measure of leeway in starting and completing an activity.

BURBANK BRANCH RENOVATIONS, PORTLAND PUBLIC LIBRARY

1.4 INFORMATIONAL SUBMITTALS

- A. Format for Submittals: Submit required submittals in the following format:
 - 1. PDF electronic file.
- B. Startup construction schedule.
- C. Contractor's Construction Schedule: Initial schedule, of size required to display entire schedule for entire construction period.
- D. Construction Schedule Updating Reports: Submit with Applications for Payment.
- E. Daily Construction Reports: Submit at weekly intervals.
- F. Material Location Reports: Submit at monthly intervals.
- G. Site Condition Reports: Submit at time of discovery of differing conditions.
- H. Special Reports: Submit at time of unusual event.
- I. Qualification Data: For scheduling consultant.

1.5 QUALITY ASSURANCE

- A. Prescheduling Conference: Conduct conference at Project site to comply with requirements in Section 013100 "Project Management and Coordination." Review methods and procedures related to the preliminary construction schedule and Contractor's construction schedule, including, but not limited to, the following:
 - 1. Discuss constraints, including work stages area separations and milestones.
 - 2. Review delivery dates for Owner-furnished products.
 - 3. Review submittal requirements and procedures.
 - 4. Review time required for review of submittals and resubmittals.
 - 5. Review requirements for tests and inspections by independent testing and inspecting agencies.
 - 6. Review time required for Project closeout and Owner startup procedures.
 - 7. Review and finalize list of construction activities to be included in schedule.
 - 8. Review procedures for updating schedule.

1.6 COORDINATION

- A. Coordinate Contractor's construction schedule with the schedule of values, list of subcontracts, submittal schedule, progress reports, payment requests, and other required schedules and reports.
 - 1. Secure time commitments for performing critical elements of the Work from entities involved.
 - 2. Coordinate each construction activity in the network with other activities and schedule them in proper sequence.

PART 2 - PRODUCTS

2.1 CONTRACTOR'S CONSTRUCTION SCHEDULE, GENERAL

- A. Time Frame: Extend schedule from date established for commencement of the Work to date of final completion.
 - 1. Contract completion date shall not be changed by submission of a schedule that shows an early completion date, unless specifically authorized by Change Order.
- B. Activities: Treat each story or separate area as a separate numbered activity for each main element of the Work. Comply with the following:
 - 1. Activity Duration: Define activities so no activity is longer than 20 days, unless specifically allowed by Architect.
 - 2. Procurement Activities: Include procurement process activities for the following long lead items and major items, requiring a cycle of more than 60 days, as separate activities in schedule. Procurement cycle activities include, but are not limited to, submittals, approvals, purchasing, fabrication, and delivery.
 - 3. Submittal Review Time: Include review and resubmittal times indicated in Section 013300 "Submittal Procedures" in schedule. Coordinate submittal review times in Contractor's construction schedule with submittal schedule.
 - 4. Startup and Testing Time: Include no fewer than 5 days for startup and testing.
 - 5. Substantial Completion: Indicate completion in advance of date established for Substantial Completion, and allow time for Architect's administrative procedures necessary for certification of Substantial Completion.
 - 6. Punch List and Final Completion: Include not more than 30 days for completion of punch list items and final completion.
- C. Constraints: Include constraints and work restrictions indicated in the Contract Documents and as follows in schedule, and show how the sequence of the Work is affected.
 - 1. Owner-Furnished Products: Include a separate activity for each product. Include delivery date indicated in Section 011000 "Summary." Delivery dates indicated stipulate the earliest possible delivery date.
 - 2. Work Restrictions: Show the effect of the following items on the schedule:
 - a. Coordination with existing construction.
 - b. Limitations of continued occupancies.
 - c. Uninterruptible services.
 - d. Partial occupancy before Substantial Completion.
 - e. Use of premises restrictions.
 - f. Provisions for future construction.
 - g. Seasonal variations.
 - h. Environmental control.
 - 3. Work Stages: Indicate important stages of construction for each major portion of the Work, including, but not limited to, the following:
 - a. Subcontract awards.

- b. Submittals.
 - c. Purchases.
 - d. Mockups.
 - e. Fabrication.
 - f. Sample testing.
 - g. Deliveries.
 - h. Installation.
 - i. Tests and inspections.
 - j. Adjusting.
 - k. Curing.
 - l. Building flush-out.
 - m. Startup and placement into final use and operation.
4. Construction Areas: Identify each major area of construction for each major portion of the Work. Indicate where each construction activity within a major area must be sequenced or integrated with other construction activities to provide for the following:
- a. Structural completion.
 - b. Temporary enclosure and space conditioning.
 - c. Permanent space enclosure.
 - d. Completion of mechanical installation.
 - e. Completion of electrical installation.
 - f. Substantial Completion.
- D. Milestones: Include milestones indicated in the Contract Documents in schedule, including, but not limited to, the Notice to Proceed, Substantial Completion, and final completion.
- E. Upcoming Work Summary: Prepare summary report indicating activities scheduled to occur or commence prior to submittal of next schedule update. Summarize the following issues:
- 1. Unresolved issues.
 - 2. Unanswered Requests for Information.
 - 3. Rejected or unreturned submittals.
 - 4. Notations on returned submittals.
 - 5. Pending modifications affecting the Work and Contract Time.

2.2 STARTUP CONSTRUCTION SCHEDULE

- A. Bar-Chart Schedule: Submit startup, horizontal, bar-chart-type construction schedule within seven days of date established for commencement of the Work.
- B. Preparation: Indicate each significant construction activity separately. Identify first workday of each week with a continuous vertical line. Outline significant construction activities for first 60 days of construction. Include skeleton diagram for the remainder of the Work and a cash requirement prediction based on indicated activities.

2.3 CONTRACTOR'S CONSTRUCTION SCHEDULE (GANTT CHART)

- A. Gantt-Chart Schedule: Submit a comprehensive, fully developed, horizontal, Gantt-chart-type, Contractor's construction schedule within 30 days of date established for commencement of the Work. Base schedule on the startup construction schedule and additional information received since the start of Project.
- B. Preparation: Indicate each significant construction activity separately. Identify first workday of each week with a continuous vertical line.
 - 1. For construction activities that require three months or longer to complete, indicate an estimated completion percentage in 10 percent increments within time bar.

2.4 REPORTS

- A. Daily Construction Reports: Prepare a daily construction report recording the following information concerning events at Project site:
 - 1. List of subcontractors at Project site.
 - 2. List of separate contractors at Project site.
 - 3. Approximate count of personnel at Project site.
 - 4. Equipment at Project site.
 - 5. Material deliveries.
 - 6. High and low temperatures and general weather conditions, including presence of rain or snow.
 - 7. Accidents.
 - 8. Meetings and significant decisions.
 - 9. Unusual events (see special reports).
 - 10. Stoppages, delays, shortages, and losses.
 - 11. Meter readings and similar recordings.
 - 12. Emergency procedures.
 - 13. Orders and requests of authorities having jurisdiction.
 - 14. Change Orders received and implemented.
 - 15. Construction Change Directives received and implemented.
 - 16. Services connected and disconnected.
 - 17. Equipment or system tests and startups.
 - 18. Partial completions and occupancies.
 - 19. Substantial Completions authorized.
- B. Material Location Reports: At monthly intervals, prepare and submit a comprehensive list of materials delivered to and stored at Project site. List shall be cumulative, showing materials previously reported plus items recently delivered. Include with list a statement of progress on and delivery dates for materials or items of equipment fabricated or stored away from Project site. Indicate the following categories for stored materials:
 - 1. Material stored prior to previous report and remaining in storage.
 - 2. Material stored prior to previous report and since removed from storage and installed.
 - 3. Material stored following previous report and remaining in storage.

BURBANK BRANCH RENOVATIONS, PORTLAND PUBLIC LIBRARY

- C. Site Condition Reports: Immediately on discovery of a difference between site conditions and the Contract Documents, prepare and submit a detailed report. Submit with a Request for Information. Include a detailed description of the differing conditions, together with recommendations for changing the Contract Documents.

2.5 SPECIAL REPORTS

- A. General: Submit special reports directly to Owner within one day of an occurrence. Distribute copies of report to parties affected by the occurrence.
- B. Reporting Unusual Events: When an event of an unusual and significant nature occurs at Project site, whether or not related directly to the Work, prepare and submit a special report. List chain of events, persons participating, response by Contractor's personnel, evaluation of results or effects, and similar pertinent information. Advise Owner in advance when these events are known or predictable.

PART 3 - EXECUTION

3.1 CONTRACTOR'S CONSTRUCTION SCHEDULE

- A. Contractor's Construction Schedule Updating: At monthly intervals, review schedule for actual construction progress and activities. Issue schedule one week before each regularly scheduled progress meeting.
 - 1. Revise schedule immediately after each meeting or other activity where revisions have been recognized or made. Issue updated schedule concurrently with the report of each such meeting.
 - 2. Include a report with updated schedule that indicates every change, including, but not limited to, changes in logic, durations, actual starts and finishes, and activity durations.
 - 3. As the Work progresses, indicate final completion percentage for each activity.
- B. Distribution: Distribute copies of approved schedule to Architect, Owner, separate contractors, testing and inspecting agencies, and other parties identified by Contractor with a need-to-know schedule responsibility.
 - 1. Post copies in Project meeting rooms and temporary field offices.
 - 2. When revisions are made, distribute updated schedules to the same parties and post in the same locations. Delete parties from distribution when they have completed their assigned portion of the Work and are no longer involved in performance of construction activities.

END OF SECTION 013200

SECTION 013300 - SUBMITTAL PROCEDURES

PART 1 - GENERAL

1.1 RELATED DOCUMENTS

- A. Drawings and general provisions of the Contract, including General and Supplementary Conditions and other Division 01 Specification Sections, apply to this Section.

1.2 SUMMARY

- A. Section includes requirements for the submittal schedule and administrative and procedural requirements for submitting Shop Drawings, Product Data, Samples, and other submittals.
- B. Related Requirements:
 - 1. Section 012900 "Payment Procedures" for submitting Applications for Payment and the schedule of values.
 - 2. Section 013200 "Construction Progress Documentation" for submitting schedules and reports, including Contractor's construction schedule.
 - 3. Section 017839 "Project Record Documents" for submitting record Drawings, record Specifications, and record Product Data.

1.3 DEFINITIONS

- A. Action Submittals: Written and graphic information and physical samples that require Architect's responsive action. Action submittals are those submittals indicated in individual Specification Sections as "action submittals."
- B. Informational Submittals: Written and graphic information and physical samples that do not require Architect's responsive action. Submittals may be rejected for not complying with requirements. Informational submittals are those submittals indicated in individual Specification Sections as "informational submittals."
- C. File Transfer Protocol (FTP): Communications protocol that enables transfer of files to and from another computer over a network and that serves as the basis for standard Internet protocols. An FTP site is a portion of a network located outside of network firewalls within which internal and external users are able to access files.
- D. Portable Document Format (PDF): An open standard file format licensed by Adobe Systems used for representing documents in a device-independent and display resolution-independent fixed-layout document format.

1.4 ACTION SUBMITTALS

- A. Submittal Schedule: Submit a schedule of submittals, arranged in chronological order by dates required by construction schedule. Include time required for review, ordering, manufacturing, fabrication, and delivery when establishing dates. Include additional time required for making corrections or revisions to submittals noted by Architect and additional time for handling and reviewing submittals required by those corrections.
1. Coordinate submittal schedule with list of subcontracts, the schedule of values, and Contractor's construction schedule.
 2. Initial Submittal: Submit concurrently with startup construction schedule. Include submittals required during the first 60 days of construction. List those submittals required to maintain orderly progress of the Work and those required early because of long lead time for manufacture or fabrication.
 3. Final Submittal: Submit concurrently with the first complete submittal of Contractor's construction schedule.
 - a. Submit revised submittal schedule to reflect changes in current status and timing for submittals.
 4. Format: Arrange the following information in a tabular format:
 - a. Scheduled date for first submittal.
 - b. Specification Section number and title.
 - c. Submittal category: Action; informational.
 - d. Name of subcontractor.
 - e. Description of the Work covered.
 - f. Scheduled date for Architect's final release or approval.
 - g. Scheduled date of fabrication.
 - h. Scheduled dates for purchasing.
 - i. Scheduled dates for installation.
 - j. Activity or event number.

1.5 SUBMITTAL ADMINISTRATIVE REQUIREMENTS

- A. Architect's Digital Data Files: Electronic digital data files of the Contract Drawings will not be provided by Architect for Contractor's use in preparing submittals.
- B. Coordination: Coordinate preparation and processing of submittals with performance of construction activities.
1. Coordinate each submittal with fabrication, purchasing, testing, delivery, other submittals, and related activities that require sequential activity.
 2. Submit all submittal items required for each Specification Section concurrently unless partial submittals for portions of the Work are indicated on approved submittal schedule.
 3. Submit action submittals and informational submittals required by the same Specification Section as separate packages under separate transmittals.
 4. Coordinate transmittal of different types of submittals for related parts of the Work so processing will not be delayed because of need to review submittals concurrently for coordination.

BURBANK BRANCH RENOVATIONS, PORTLAND PUBLIC LIBRARY

- a. Architect reserves the right to withhold action on a submittal requiring coordination with other submittals until related submittals are received.
- C. Processing Time: Allow time for submittal review, including time for resubmittals, as follows. Time for review shall commence on Architect's receipt of submittal. No extension of the Contract Time will be authorized because of failure to transmit submittals enough in advance of the Work to permit processing, including resubmittals.
1. Initial Review: Allow 15 days for initial review of each submittal. Allow additional time if coordination with subsequent submittals is required. Architect will advise Contractor when a submittal being processed must be delayed for coordination.
 2. Intermediate Review: If intermediate submittal is necessary, process it in same manner as initial submittal.
 3. Resubmittal Review: Allow 15 days for review of each resubmittal.
 4. Sequential Review: Where sequential review of submittals by Architect's consultants, Owner, or other parties is indicated, allow 21 days for initial review of each submittal.
 - a. Sitework submittals.
 - b. Mechanical submittals.
 - c. Electrical submittals.
 - d. Data & Communications Systems submittals.
 5. No extension of the Contract Time will be authorized because of failure to transmit submittals enough in advance of the Work to permit processing.
 6. Submittals with Color Selections: Deliver to Architect a list of submittals required for the exterior color package and a list required for the interior color package. The Architect needs to coordinate the colors of all exterior and interior items and will hold submittals with color selections until all materials in the exterior color package have been received. Allow 2 weeks after the last item has been submitted for return of exterior color selections. The Architect will hold submittals with color selections until all materials in the interior color package have been received. Allow 3 weeks after the last item has been submitted for return of interior color selections. Careful coordination of the Submittal Schedule by the Contractor is required so as not to delay the Work.
- D. Electronic Submittals: Identify and incorporate information in each electronic submittal file as follows:
1. Assemble complete submittal package into a single indexed file incorporating submittal requirements of a single Specification Section and transmittal form with links enabling navigation to each item.
 2. Name file with submittal number or other unique identifier, including revision identifier.
 - a. File name shall use project identifier and Specification Section number followed by a decimal point and then a sequential number (e.g., ABCD-061000.01). Resubmittals shall include an alphabetic suffix after another decimal point (e.g., ABCD-061000.01.A).
 3. Provide means for insertion to permanently record Contractor's review and approval markings and action taken by Architect.

BURBANK BRANCH RENOVATIONS, PORTLAND PUBLIC LIBRARY

4. Transmittal Form for Electronic Submittals: Use software-generated form from electronic project management software or electronic form acceptable to Owner, containing the following information:
 - a. Project name.
 - b. Date.
 - c. Name and address of Architect.
 - d. Name of Contractor.
 - e. Name of firm or entity that prepared submittal.
 - f. Names of subcontractor, manufacturer, and supplier.
 - g. Category and type of submittal.
 - h. Submittal purpose and description.
 - i. Specification Section number and title.
 - j. Specification paragraph number or drawing designation and generic name for each of multiple items.
 - k. Drawing number and detail references, as appropriate.
 - l. Location(s) where product is to be installed, as appropriate.
 - m. Related physical samples submitted directly.
 - n. Indication of full or partial submittal.
 - o. Transmittal number, numbered consecutively.
 - p. Submittal and transmittal distribution record.
 - q. Other necessary identification.
 - r. Remarks.
5. Metadata: Include the following information as keywords in the electronic submittal file metadata:
 - a. Project name.
 - b. Number and title of appropriate Specification Section.
 - c. Manufacturer name.
 - d. Product name.
- E. Options: Identify options requiring selection by Architect.
- F. Deviations and Additional Information: On an attached separate sheet, prepared on Contractor's letterhead, record relevant information, requests for data, revisions other than those requested by Architect on previous submittals, and deviations from requirements in the Contract Documents, including minor variations and limitations. Include same identification information as related submittal.
- G. Resubmittals: Make resubmittals in same form and number of copies as initial submittal.
 1. Note date and content of previous submittal.
 2. Note date and content of revision in label or title block and clearly indicate extent of revision.
 3. Resubmit submittals until they are marked with approval notation from Architect's action stamp.
- H. Distribution: Furnish copies of final submittals to manufacturers, subcontractors, suppliers, fabricators, installers, authorities having jurisdiction, and others as necessary for performance of construction activities. Show distribution on transmittal forms.

BURBANK BRANCH RENOVATIONS, PORTLAND PUBLIC LIBRARY

- I. Use for Construction: Retain complete copies of submittals on Project site. Use only final action submittals that are marked with approval notation from Architect's action stamp.

PART 2 - PRODUCTS

2.1 SUBMITTAL PROCEDURES

- A. General Submittal Procedure Requirements: Prepare and submit submittals required by individual Specification Sections. Types of submittals are indicated in individual Specification Sections.
 1. Submit electronic submittals via email as PDF electronic files.
 - a. Architect will return annotated file. Annotate and retain one copy of file as an electronic Project record document file.
 2. Informational Submittals: Submit two paper copies of each submittal unless otherwise indicated. Architect will not return copies.
 3. Certificates and Certifications Submittals: Provide a statement that includes signature of entity responsible for preparing certification. Certificates and certifications shall be signed by an officer or other individual authorized to sign documents on behalf of that entity.
 - a. Provide a digital signature with digital certificate on electronically submitted certificates and certifications where indicated.
 - b. Provide a notarized statement on original paper copy certificates and certifications where indicated.
- B. Product Data: Collect information into a single submittal for each element of construction and type of product or equipment.
 1. If information must be specially prepared for submittal because standard published data are not suitable for use, submit as Shop Drawings, not as Product Data.
 2. Mark each copy of each submittal to show which products and options are applicable.
 3. Include the following information, as applicable:
 - a. Manufacturer's catalog cuts.
 - b. Manufacturer's product specifications.
 - c. Standard color charts.
 - d. Statement of compliance with specified referenced standards.
 - e. Testing by recognized testing agency.
 - f. Application of testing agency labels and seals.
 - g. Manufacturer's Safety and Data Sheets (MSDS).
 - h. Notation of coordination requirements.
 - i. Availability and delivery time information.
 4. For equipment, include the following in addition to the above, as applicable:
 - a. Wiring diagrams showing factory-installed wiring.

BURBANK BRANCH RENOVATIONS, PORTLAND PUBLIC LIBRARY

- b. Printed performance curves.
 - c. Operational range diagrams.
 - d. Clearances required to other construction, if not indicated on accompanying Shop Drawings.
 5. Submit Product Data before or concurrent with Samples.
 6. Submit Product Data in the following format:
 - a. PDF electronic file.
- C. Shop Drawings: Prepare Project-specific information, drawn accurately to scale. Do not base Shop Drawings on reproductions of the Contract Documents or standard printed data.
 1. Preparation: Fully illustrate requirements in the Contract Documents. Include the following information, as applicable:
 - a. Identification of products.
 - b. Schedules.
 - c. Compliance with specified standards.
 - d. Notation of coordination requirements.
 - e. Notation of dimensions established by field measurement.
 - f. Relationship and attachment to adjoining construction clearly indicated.
 - g. Seal and signature of professional engineer if specified.
 2. Sheet Size: Except for templates, patterns, and similar full-size drawings, submit Shop Drawings on sheets at least 8-1/2 by 11 inches, but no larger than 30 by 42 inches.
 3. Submit Shop Drawings in the following format:
 - a. PDF electronic file.
- D. Samples: Submit Samples for review of kind, color, pattern, and texture for a check of these characteristics with other elements and for a comparison of these characteristics between submittal and actual component as delivered and installed.
 1. Transmit Samples that contain multiple, related components such as accessories together in one submittal package.
 2. Identification: Attach label on unexposed side of Samples that includes the following:
 - a. Generic description of Sample.
 - b. Product name and name of manufacturer.
 - c. Sample source.
 - d. Number and title of applicable Specification Section.
 - e. Specification paragraph number and generic name of each item.
 3. For projects where electronic submittals are required, provide corresponding electronic submittal of Sample transmittal, digital image file illustrating Sample characteristics, and identification information for record.
 4. Disposition: Maintain sets of approved Samples at Project site, available for quality-control comparisons throughout the course of construction activity. Sample sets may be used to determine final acceptance of construction associated with each set.

BURBANK BRANCH RENOVATIONS, PORTLAND PUBLIC LIBRARY

- a. Samples that may be incorporated into the Work are indicated in individual Specification Sections. Such Samples must be in an undamaged condition at time of use.
 - b. Samples not incorporated into the Work, or otherwise designated as Owner's property, are the property of Contractor.
5. Samples for Initial Selection: Submit manufacturer's color charts consisting of units or sections of units showing the full range of colors, textures, and patterns available.
 - a. Number of Samples: Submit one full set of available choices where color, pattern, texture, or similar characteristics are required to be selected from manufacturer's product line. Architect will return submittal with options selected.
6. Samples for Verification: Submit full-size units or Samples of size indicated, prepared from same material to be used for the Work, cured and finished in manner specified, and physically identical with material or product proposed for use, and that show full range of color and texture variations expected. Samples include, but are not limited to, the following: partial sections of manufactured or fabricated components; small cuts or containers of materials; complete units of repetitively used materials; swatches showing color, texture, and pattern; color range sets; and components used for independent testing and inspection.
 - a. Number of Samples: Submit three sets of Samples. Architect will retain two Sample sets; remainder will be returned. Mark up and retain one returned Sample set as a project record sample.
 - 1) Submit a single Sample where assembly details, workmanship, fabrication techniques, connections, operation, and other similar characteristics are to be demonstrated.
 - 2) If variation in color, pattern, texture, or other characteristic is inherent in material or product represented by a Sample, submit at least three sets of paired units that show approximate limits of variations.
- E. Contractor's Construction Schedule: Comply with requirements specified in Section 013200 "Construction Progress Documentation."
- F. Application for Payment and Schedule of Values: Comply with requirements specified in Section 012900 "Payment Procedures."
- G. Test and Inspection Reports and Schedule of Tests and Inspections Submittals: Comply with requirements specified in Section 014000 "Quality Requirements."
- H. Closeout Submittals and Maintenance Material Submittals: Comply with requirements specified in Section 017700 "Closeout Procedures."
- I. Maintenance Data: Comply with requirements specified in Section 017823 "Operation and Maintenance Data."
- J. Qualification Data: Prepare written information that demonstrates capabilities and experience of firm or person. Include lists of completed projects with project names and addresses, contact information of architects and owners, and other information specified.

BURBANK BRANCH RENOVATIONS, PORTLAND PUBLIC LIBRARY

- K. Welding Certificates: Prepare written certification that welding procedures and personnel comply with requirements in the Contract Documents. Submit record of Welding Procedure Specification and Procedure Qualification Record on AWS forms. Include names of firms and personnel certified.
- L. Installer Certificates: Submit written statements on manufacturer's letterhead certifying that Installer complies with requirements in the Contract Documents and, where required, is authorized by manufacturer for this specific Project.
- M. Manufacturer Certificates: Submit written statements on manufacturer's letterhead certifying that manufacturer complies with requirements in the Contract Documents. Include evidence of manufacturing experience where required.
- N. Product Certificates: Submit written statements on manufacturer's letterhead certifying that product complies with requirements in the Contract Documents.
- O. Material Certificates: Submit written statements on manufacturer's letterhead certifying that material complies with requirements in the Contract Documents.
- P. Material Test Reports: Submit reports written by a qualified testing agency, on testing agency's standard form, indicating and interpreting test results of material for compliance with requirements in the Contract Documents.
- Q. Product Test Reports: Submit written reports indicating that current product produced by manufacturer complies with requirements in the Contract Documents. Base reports on evaluation of tests performed by manufacturer and witnessed by a qualified testing agency, or on comprehensive tests performed by a qualified testing agency.
- R. Research Reports: Submit written evidence, from a model code organization acceptable to authorities having jurisdiction, that product complies with building code in effect for Project. Include the following information:
 - 1. Name of evaluation organization.
 - 2. Date of evaluation.
 - 3. Time period when report is in effect.
 - 4. Product and manufacturers' names.
 - 5. Description of product.
 - 6. Test procedures and results.
 - 7. Limitations of use.
- S. Preconstruction Test Reports: Submit reports written by a qualified testing agency, on testing agency's standard form, indicating and interpreting results of tests performed before installation of product, for compliance with performance requirements in the Contract Documents.
- T. Compatibility Test Reports: Submit reports written by a qualified testing agency, on testing agency's standard form, indicating and interpreting results of compatibility tests performed before installation of product. Include written recommendations for primers and substrate preparation needed for adhesion.

BURBANK BRANCH RENOVATIONS, PORTLAND PUBLIC LIBRARY

- U. Field Test Reports: Submit written reports indicating and interpreting results of field tests performed either during installation of product or after product is installed in its final location, for compliance with requirements in the Contract Documents.
- V. Design Data: Prepare and submit written and graphic information, including, but not limited to, performance and design criteria, list of applicable codes and regulations, and calculations. Include list of assumptions and other performance and design criteria and a summary of loads. Include load diagrams if applicable. Provide name and version of software, if any, used for calculations. Include page numbers.

PART 3 - EXECUTION

3.1 CONTRACTOR'S REVIEW

- A. Action and Informational Submittals: Review each submittal and check for coordination with other Work of the Contract and for compliance with the Contract Documents. Note corrections and field dimensions. Mark with approval stamp before submitting to Architect.
- B. Project Closeout and Maintenance Material Submittals: See requirements in Section 017700 "Closeout Procedures."
- C. Approval Stamp: Stamp each submittal with a uniform, approval stamp. Include Project name and location, submittal number, Specification Section title and number, name of reviewer, date of Contractor's approval, and statement certifying that submittal has been reviewed, checked, and approved for compliance with the Contract Documents.
 - 1. Stamp or statement shall include the following: "The Contractor represents that he has determined and verified all materials, field measurements, and field construction criteria related thereto or will do so, and that he has checked and coordinated the information contained within such submittals with the requirements of the Work and of the Contract Documents."

3.2 ARCHITECT'S ACTION

- A. Action Submittals: Architect will review each submittal, make marks to indicate corrections or revisions required, and return it. Architect will stamp each submittal with an action stamp and will mark stamp appropriately to indicate action.
- B. Informational Submittals: Architect will review each submittal and will not return it, or will return it if it does not comply with requirements. Architect will forward each submittal to appropriate party.
- C. Partial submittals prepared for a portion of the Work will be reviewed when use of partial submittals has received prior approval from Architect.
- D. Incomplete submittals are unacceptable, will be considered nonresponsive, and will be returned for resubmittal without review.

BURBANK BRANCH RENOVATIONS, PORTLAND PUBLIC LIBRARY

- E. Submittals not required by the Contract Documents may be returned by the Architect without action.

END OF SECTION 013300

SECTION 014000 - QUALITY REQUIREMENTS

PART 1 - GENERAL

1.1 RELATED DOCUMENTS

- A. Drawings and general provisions of the Contract, including General and Supplementary Conditions and other Division 01 Specification Sections, apply to this Section.

1.2 SUMMARY

- A. Section includes administrative and procedural requirements for quality assurance and quality control.
- B. Testing and inspecting services are required to verify compliance with requirements specified or indicated. These services do not relieve Contractor of responsibility for compliance with the Contract Document requirements.
 - 1. Specific quality-assurance and -control requirements for individual construction activities are specified in the Sections that specify those activities. Requirements in those Sections may also cover production of standard products.
 - 2. Specified tests, inspections, and related actions do not limit Contractor's other quality-assurance and -control procedures that facilitate compliance with the Contract Document requirements.
 - 3. Requirements for Contractor to provide quality-assurance and -control services required by Architect, Owner, or authorities having jurisdiction are not limited by provisions of this Section.
 - 4. Specific test and inspection requirements are not specified in this Section.

1.3 DEFINITIONS

- A. Quality-Assurance Services: Activities, actions, and procedures performed before and during execution of the Work to guard against defects and deficiencies and substantiate that proposed construction will comply with requirements.
- B. Quality-Control Services: Tests, inspections, procedures, and related actions during and after execution of the Work to evaluate that actual products incorporated into the Work and completed construction comply with requirements. Services do not include contract enforcement activities performed by Architect.
- C. Mockups: Full-size physical assemblies that are constructed on-site. Mockups are constructed to verify selections made under Sample submittals; to demonstrate aesthetic effects and, where indicated, qualities of materials and execution; to review coordination, testing, or operation; to show interface between dissimilar materials; and to demonstrate compliance with specified installation tolerances. Mockups are not Samples. Unless otherwise indicated, approved mockups establish the standard by which the Work will be judged.

BURBANK BRANCH RENOVATIONS, PORTLAND PUBLIC LIBRARY

- D. Preconstruction Testing: Tests and inspections performed specifically for Project before products and materials are incorporated into the Work, to verify performance or compliance with specified criteria.
- E. Product Testing: Tests and inspections that are performed by an NRTL, an NVLAP, or a testing agency qualified to conduct product testing and acceptable to authorities having jurisdiction, to establish product performance and compliance with specified requirements.
- F. Source Quality-Control Testing: Tests and inspections that are performed at the source, e.g., plant, mill, factory, or shop.
- G. Field Quality-Control Testing: Tests and inspections that are performed on-site for installation of the Work and for completed Work.
- H. Testing Agency: An entity engaged to perform specific tests, inspections, or both. Testing laboratory shall mean the same as testing agency.
- I. Installer/Applicator/Erector: Contractor or another entity engaged by Contractor as an employee, Subcontractor, or Sub-subcontractor, to perform a particular construction operation, including installation, erection, application, and similar operations.
 - 1. Use of trade-specific terminology in referring to a trade or entity does not require that certain construction activities be performed by accredited or unionized individuals, or that requirements specified apply exclusively to specific trade(s).
- J. Experienced: When used with an entity or individual, "experienced" means having successfully completed a minimum of five previous projects similar in nature, size, and extent to this Project; being familiar with special requirements indicated; and having complied with requirements of authorities having jurisdiction.

1.4 CONFLICTING REQUIREMENTS

- A. Referenced Standards: If compliance with two or more standards is specified and the standards establish different or conflicting requirements for minimum quantities or quality levels, comply with the most stringent requirement. Refer conflicting requirements that are different, but apparently equal, to Architect for a decision before proceeding.
- B. Minimum Quantity or Quality Levels: The quantity or quality level shown or specified shall be the minimum provided or performed. The actual installation may comply exactly with the minimum quantity or quality specified, or it may exceed the minimum within reasonable limits. To comply with these requirements, indicated numeric values are minimum or maximum, as appropriate, for the context of requirements. Refer uncertainties to Architect for a decision before proceeding.

1.5 INFORMATIONAL SUBMITTALS

- A. Contractor's Quality-Control Plan: For quality-assurance and quality-control activities and responsibilities.

BURBANK BRANCH RENOVATIONS, PORTLAND PUBLIC LIBRARY

- B. Qualification Data: For Contractor's quality-control personnel.
- C. Testing Agency Qualifications: For testing agencies specified in "Quality Assurance" Article to demonstrate their capabilities and experience. Include proof of qualifications in the form of a recent report on the inspection of the testing agency by a recognized authority.
- D. Schedule of Tests and Inspections: Prepare in tabular form and include the following:
 - 1. Specification Section number and title.
 - 2. Entity responsible for performing tests and inspections.
 - 3. Description of test and inspection.
 - 4. Identification of applicable standards.
 - 5. Identification of test and inspection methods.
 - 6. Number of tests and inspections required.
 - 7. Time schedule or time span for tests and inspections.
 - 8. Requirements for obtaining samples.
 - 9. Unique characteristics of each quality-control service.

1.6 CONTRACTOR'S QUALITY-CONTROL PLAN

- A. Quality-Control Plan, General: Submit quality-control plan within 10 days of Notice of Award or Notice to Proceed, and not less than five days prior to preconstruction conference. Submit in format acceptable to Architect. Identify personnel, procedures, controls, instructions, tests, records, and forms to be used to carry out Contractor's quality-assurance and quality-control responsibilities. Coordinate with Contractor's construction schedule.
- B. Quality-Control Personnel Qualifications: Engage qualified full-time personnel trained and experienced in managing and executing quality-assurance and quality-control procedures similar in nature and extent to those required for Project.
 - 1. Project quality-control manager may also serve as Project superintendent.
- C. Submittal Procedure: Describe procedures for ensuring compliance with requirements through review and management of submittal process. Indicate qualifications of personnel responsible for submittal review.
- D. Testing and Inspection: In quality-control plan, include a comprehensive schedule of Work requiring testing or inspection, including the following:
 - 1. Contractor-performed tests and inspections including subcontractor-performed tests and inspections. Include required tests and inspections and Contractor-elected tests and inspections.
 - 2. Owner-performed tests and inspections indicated in the Contract Documents.
- E. Continuous Inspection of Workmanship: Describe process for continuous inspection during construction to identify and correct deficiencies in workmanship in addition to testing and inspection specified. Indicate types of corrective actions to be required to bring work into compliance with standards of workmanship established by Contract requirements and approved mockups.

BURBANK BRANCH RENOVATIONS, PORTLAND PUBLIC LIBRARY

- F. Monitoring and Documentation: Maintain testing and inspection reports including log of approved and rejected results. Include work Architect has indicated as nonconforming or defective. Indicate corrective actions taken to bring nonconforming work into compliance with requirements. Comply with requirements of authorities having jurisdiction.

1.7 REPORTS AND DOCUMENTS

- A. Test and Inspection Reports: Prepare and submit certified written reports specified in other Sections. Include the following:

1. Date of issue.
2. Project title and number.
3. Name, address, and telephone number of testing agency.
4. Dates and locations of samples and tests or inspections.
5. Names of individuals making tests and inspections.
6. Description of the Work and test and inspection method.
7. Identification of product and Specification Section.
8. Complete test or inspection data.
9. Test and inspection results and an interpretation of test results.
10. Record of temperature and weather conditions at time of sample taking and testing and inspecting.
11. Comments or professional opinion on whether tested or inspected Work complies with the Contract Document requirements.
12. Name and signature of laboratory inspector.
13. Recommendations on retesting and reinspecting.

- B. Manufacturer's Technical Representative's Field Reports: Prepare written information documenting manufacturer's technical representative's tests and inspections specified in other Sections. Include the following:

1. Name, address, and telephone number of technical representative making report.
2. Statement on condition of substrates and their acceptability for installation of product.
3. Statement that products at Project site comply with requirements.
4. Summary of installation procedures being followed, whether they comply with requirements and, if not, what corrective action was taken.
5. Results of operational and other tests and a statement of whether observed performance complies with requirements.
6. Statement whether conditions, products, and installation will affect warranty.
7. Other required items indicated in individual Specification Sections.

- C. Factory-Authorized Service Representative's Reports: Prepare written information documenting manufacturer's factory-authorized service representative's tests and inspections specified in other Sections. Include the following:

1. Name, address, and telephone number of factory-authorized service representative making report.
2. Statement that equipment complies with requirements.
3. Results of operational and other tests and a statement of whether observed performance complies with requirements.
4. Statement whether conditions, products, and installation will affect warranty.

5. Other required items indicated in individual Specification Sections.

- D. Permits, Licenses, and Certificates: For Owner's records, submit copies of permits, licenses, certifications, inspection reports, releases, jurisdictional settlements, notices, receipts for fee payments, judgments, correspondence, records, and similar documents, established for compliance with standards and regulations bearing on performance of the Work.

1.8 QUALITY ASSURANCE

- A. General: Qualifications paragraphs in this article establish the minimum qualification levels required; individual Specification Sections specify additional requirements.
- B. Manufacturer Qualifications: A firm experienced in manufacturing products or systems similar to those indicated for this Project and with a record of successful in-service performance, as well as sufficient production capacity to produce required units.
- C. Fabricator Qualifications: A firm experienced in producing products similar to those indicated for this Project and with a record of successful in-service performance, as well as sufficient production capacity to produce required units.
- D. Installer Qualifications: A firm or individual experienced in installing, erecting, or assembling work similar in material, design, and extent to that indicated for this Project, whose work has resulted in construction with a record of successful in-service performance.
- E. Professional Engineer Qualifications: A professional engineer who is legally qualified to practice in jurisdiction where Project is located and who is experienced in providing engineering services of the kind indicated. Engineering services are defined as those performed for installations of the system, assembly, or product that are similar in material, design, and extent to those indicated for this Project.
- F. Specialists: Certain Specification Sections require that specific construction activities shall be performed by entities who are recognized experts in those operations. Specialists shall satisfy qualification requirements indicated and shall be engaged for the activities indicated.
1. Requirements of authorities having jurisdiction shall supersede requirements for specialists.
- G. Testing Agency Qualifications: An NRTL, an NVLAP, or an independent agency with the experience and capability to conduct testing and inspecting indicated, as documented according to ASTM E 329; and with additional qualifications specified in individual Sections; and, where required by authorities having jurisdiction, that is acceptable to authorities.
1. NRTL: A nationally recognized testing laboratory according to 29 CFR 1910.7.
 2. NVLAP: A testing agency accredited according to NIST's National Voluntary Laboratory Accreditation Program.
- H. Manufacturer's Technical Representative Qualifications: An authorized representative of manufacturer who is trained and approved by manufacturer to observe and inspect installation of manufacturer's products that are similar in material, design, and extent to those indicated for this Project.

BURBANK BRANCH RENOVATIONS, PORTLAND PUBLIC LIBRARY

- I. Factory-Authorized Service Representative Qualifications: An authorized representative of manufacturer who is trained and approved by manufacturer to inspect installation of manufacturer's products that are similar in material, design, and extent to those indicated for this Project.
- J. Preconstruction Testing: Where testing agency is indicated to perform preconstruction testing for compliance with specified requirements for performance and test methods, comply with the following:
 - 1. Contractor responsibilities include the following:
 - a. Provide test specimens representative of proposed products and construction.
 - b. Submit specimens in a timely manner with sufficient time for testing and analyzing results to prevent delaying the Work.
 - c. Provide sizes and configurations of test assemblies, mockups, and laboratory mockups to adequately demonstrate capability of products to comply with performance requirements.
 - d. Build site-assembled test assemblies and mockups using installers who will perform same tasks for Project.
 - e. Build laboratory mockups at testing facility using personnel, products, and methods of construction indicated for the completed Work.
 - f. When testing is complete, remove test specimens, assemblies, and mockups, and laboratory mockups; do not reuse products on Project.
 - 2. Testing Agency Responsibilities: Submit a certified written report of each test, inspection, and similar quality-assurance service to Architect, with copy to Contractor. Interpret tests and inspections and state in each report whether tested and inspected work complies with or deviates from the Contract Documents.
- K. Mockups: Before installing portions of the Work requiring mockups, build mockups for each form of construction and finish required to comply with the following requirements, using materials indicated for the completed Work:
 - 1. Build mockups in location and of size indicated or, if not indicated, as directed by Architect.
 - 2. Notify Architect seven days in advance of dates and times when mockups will be constructed.
 - 3. Employ supervisory personnel who will oversee mockup construction. Employ workers that will be employed during the construction at Project.
 - 4. Demonstrate the proposed range of aesthetic effects and workmanship.
 - 5. Obtain Architect's approval of mockups before starting work, fabrication, or construction.
 - 6. Maintain mockups during construction in an undisturbed condition as a standard for judging the completed Work.
 - 7. Demolish and remove mockups when directed unless otherwise indicated.

1.9 QUALITY CONTROL

- A. Owner Responsibilities: Where quality-control services are indicated as Owner's responsibility, Owner will engage a qualified testing agency to perform these services.

BURBANK BRANCH RENOVATIONS, PORTLAND PUBLIC LIBRARY

1. Owner will furnish Contractor with names, addresses, and telephone numbers of testing agencies engaged and a description of types of testing and inspecting they are engaged to perform.
 2. Payment for these services will be made from testing and inspecting allowances, as authorized by Change Orders.
 3. Costs for retesting and reinspecting construction that replaces or is necessitated by work that failed to comply with the Contract Documents will be charged to Contractor.
- B. Contractor Responsibilities: Tests and inspections not explicitly assigned to Owner are Contractor's responsibility. Perform additional quality-control activities required to verify that the Work complies with requirements, whether specified or not.
1. Unless otherwise indicated, provide quality-control services specified and those required by authorities having jurisdiction. Perform quality-control services required of Contractor by authorities having jurisdiction, whether specified or not.
 2. Where services are indicated as Contractor's responsibility, engage a qualified testing agency to perform these quality-control services.
 - a. Contractor shall not employ same entity engaged by Owner, unless agreed to in writing by Owner.
 3. Notify testing agencies at least 24 hours in advance of time when Work that requires testing or inspecting will be performed.
 4. Where quality-control services are indicated as Contractor's responsibility, submit a certified written report, in duplicate, of each quality-control service.
 5. Testing and inspecting requested by Contractor and not required by the Contract Documents are Contractor's responsibility.
 6. Submit additional copies of each written report directly to authorities having jurisdiction, when they so direct.
- C. Manufacturer's Field Services: Where indicated, engage a factory-authorized service representative to inspect field-assembled components and equipment installation, including service connections. Report results in writing as specified in Section 013300 "Submittal Procedures."
- D. Manufacturer's Technical Services: Where indicated, engage a manufacturer's technical representative to observe and inspect the Work. Manufacturer's technical representative's services include participation in preinstallation conferences, examination of substrates and conditions, verification of materials, observation of Installer activities, inspection of completed portions of the Work, and submittal of written reports.
- E. Retesting/Reinspecting: Regardless of whether original tests or inspections were Contractor's responsibility, provide quality-control services, including retesting and reinspecting, for construction that replaced Work that failed to comply with the Contract Documents.
- F. Testing Agency Responsibilities: Cooperate with Architect and Contractor in performance of duties. Provide qualified personnel to perform required tests and inspections.
1. Notify Architect and Contractor promptly of irregularities or deficiencies observed in the Work during performance of its services.

BURBANK BRANCH RENOVATIONS, PORTLAND PUBLIC LIBRARY

2. Determine the location from which test samples will be taken and in which in-situ tests are conducted.
 3. Conduct and interpret tests and inspections and state in each report whether tested and inspected work complies with or deviates from requirements.
 4. Submit a certified written report, in duplicate, of each test, inspection, and similar quality-control service through Contractor.
 5. Do not release, revoke, alter, or increase the Contract Document requirements or approve or accept any portion of the Work.
 6. Do not perform any duties of Contractor.
- G. Associated Services: Cooperate with agencies performing required tests, inspections, and similar quality-control services, and provide reasonable auxiliary services as requested. Notify agency sufficiently in advance of operations to permit assignment of personnel. Provide the following:
1. Access to the Work.
 2. Incidental labor and facilities necessary to facilitate tests and inspections.
 3. Adequate quantities of representative samples of materials that require testing and inspecting. Assist agency in obtaining samples.
 4. Facilities for storage and field curing of test samples.
 5. Delivery of samples to testing agencies.
 6. Preliminary design mix proposed for use for material mixes that require control by testing agency.
 7. Security and protection for samples and for testing and inspecting equipment at Project site.
- H. Coordination: Coordinate sequence of activities to accommodate required quality-assurance and -control services with a minimum of delay and to avoid necessity of removing and replacing construction to accommodate testing and inspecting.
1. Schedule times for tests, inspections, obtaining samples, and similar activities.
- I. Schedule of Tests and Inspections: Prepare a schedule of tests, inspections, and similar quality-control services required by the Contract Documents as a component of Contractor's quality-control plan. Coordinate and submit concurrently with Contractor's construction schedule. Update as the Work progresses.
1. Distribution: Distribute schedule to Owner, Architect, testing agencies, and each party involved in performance of portions of the Work where tests and inspections are required.

PART 2 - PRODUCTS (Not Used)

PART 3 - EXECUTION

3.1 TEST AND INSPECTION LOG

- A. Test and Inspection Log: Prepare a record of tests and inspections. Include the following:

BURBANK BRANCH RENOVATIONS, PORTLAND PUBLIC LIBRARY

1. Date test or inspection was conducted.
 2. Description of the Work tested or inspected.
 3. Date test or inspection results were transmitted to Architect.
 4. Identification of testing agency or special inspector conducting test or inspection.
- B. Maintain log at Project site. Post changes and revisions as they occur. Provide access to test and inspection log for Architect's reference during normal working hours.

3.2 REPAIR AND PROTECTION

- A. General: On completion of testing, inspecting, sample taking, and similar services, repair damaged construction and restore substrates and finishes.
1. Provide materials and comply with installation requirements specified in other Specification Sections or matching existing substrates and finishes. Restore patched areas and extend restoration into adjoining areas with durable seams that are as invisible as possible. Comply with the Contract Document requirements for cutting and patching in Section 017300 "Execution."
- B. Protect construction exposed by or for quality-control service activities.
- C. Repair and protection are Contractor's responsibility, regardless of the assignment of responsibility for quality-control services.

END OF SECTION 014000

SECTION 014200 - REFERENCES

PART 1 - GENERAL

1.1 RELATED DOCUMENTS

- A. Drawings and general provisions of the Contract, including General and Supplementary Conditions and other Division 01 Specification Sections, apply to this Section.

1.2 DEFINITIONS

- A. General: Basic Contract definitions are included in the Conditions of the Contract.
- B. "Approved": When used to convey Architect's action on Contractor's submittals, applications, and requests, "approved" is limited to Architect's duties and responsibilities as stated in the Conditions of the Contract.
- C. "Directed": A command or instruction by Architect. Other terms including "requested," "authorized," "selected," "required," and "permitted" have the same meaning as "directed."
- D. "Indicated": Requirements expressed by graphic representations or in written form on Drawings, in Specifications, and in other Contract Documents. Other terms including "shown," "noted," "scheduled," and "specified" have the same meaning as "indicated."
- E. "Regulations": Laws, ordinances, statutes, and lawful orders issued by authorities having jurisdiction, and rules, conventions, and agreements within the construction industry that control performance of the Work.
- F. "Furnish": Supply and deliver to Project site, ready for unloading, unpacking, assembly, installation, and similar operations.
- G. "Install": Unload, temporarily store, unpack, assemble, erect, place, anchor, apply, work to dimension, finish, cure, protect, clean, and similar operations at Project site.
- H. "Provide": Furnish and install, complete and ready for the intended use.
- I. "Project Site": Space available for performing construction activities. The extent of Project site is shown on Drawings and may or may not be identical with the description of the land on which Project is to be built.
- J. Substantial Completion: The stage in the progress of the Work when the Work or designated portion thereof is sufficiently complete in accordance with the Contract Documents so the Owner can occupy or utilize the Work for its intended use. Minor corrections and repairs that can be performed while the Owner has occupied the building and without undue annoyance to personnel will be acceptable under the definition of Substantial Completion. It shall also include major final cleaning required under the Contract, removal of all surplus equipment and material not required for completion or remaining work, and the placement of remaining materials and equipment in convenient locations as approved by the Owner.

BURBANK BRANCH RENOVATIONS, PORTLAND PUBLIC LIBRARY

1.3 INDUSTRY STANDARDS

- A. Applicability of Standards: Unless the Contract Documents include more stringent requirements, applicable construction industry standards have the same force and effect as if bound or copied directly into the Contract Documents to the extent referenced. Such standards are made a part of the Contract Documents by reference.
- B. Publication Dates: Comply with standards in effect as of date of the Contract Documents unless otherwise indicated.
- C. Copies of Standards: Each entity engaged in construction on Project should be familiar with industry standards applicable to its construction activity. Copies of applicable standards are not bound with the Contract Documents.
 - 1. Where copies of standards are needed to perform a required construction activity, obtain copies directly from publication source.

1.4 ABBREVIATIONS AND ACRONYMS

- A. Industry Organizations: Where abbreviations and acronyms are used in Specifications or other Contract Documents, they shall mean the recognized name of the entities indicated in Gale's "Encyclopedia of Associations: National Organizations of the U.S." or in Columbia Books' "National Trade & Professional Associations of the United States."
- B. Code Agencies: Where abbreviations and acronyms are used in Specifications or other Contract Documents, they shall mean the recognized name of the entities in the following list. This information is believed to be accurate as of the date of the Contract Documents.
 - 1. DIN - Deutsches Institut fur Normung e.V.; www.din.de.
 - 2. IAPMO - International Association of Plumbing and Mechanical Officials; www.iapmo.org.
 - 3. ICC - International Code Council; www.iccsafe.org.
 - 4. ICC-ES - ICC Evaluation Service, LLC; www.icc-es.org.
- C. Federal Government Agencies: Where abbreviations and acronyms are used in Specifications or other Contract Documents, they shall mean the recognized name of the entities in the following list. Information is subject to change and is up-to-date as of the date of the Contract Documents.
 - 1. COE - Army Corps of Engineers; www.usace.army.mil.
 - 2. CPSC - Consumer Product Safety Commission; www.cpsc.gov.
 - 3. DOC - Department of Commerce; National Institute of Standards and Technology; www.nist.gov.
 - 4. DOD - Department of Defense; <http://dodssp.daps.dla.mil>.
 - 5. DOE - Department of Energy; www.energy.gov.
 - 6. EPA - Environmental Protection Agency; www.epa.gov.
 - 7. FAA - Federal Aviation Administration; www.faa.gov.
 - 8. FG - Federal Government Publications; www.gpo.gov.
 - 9. GSA - General Services Administration; www.gsa.gov.
 - 10. HUD - Department of Housing and Urban Development; www.hud.gov.

BURBANK BRANCH RENOVATIONS, PORTLAND PUBLIC LIBRARY

11. LBL - Lawrence Berkeley National Laboratory; Environmental Energy Technologies Division; <http://eetd.lbl.gov>.
12. OSHA - Occupational Safety & Health Administration; www.osha.gov.
13. SD - Department of State; www.state.gov.
14. TRB - Transportation Research Board; National Cooperative Highway Research Program; www.trb.org.
15. USDA - Department of Agriculture; Agriculture Research Service; U.S. Salinity Laboratory; www.ars.usda.gov.
16. USDA - Department of Agriculture; Rural Utilities Service; www.usda.gov.
17. USDJ - Department of Justice; Office of Justice Programs; National Institute of Justice; www.ojp.usdoj.gov.
18. USP - U.S. Pharmacopeia; www.usp.org.
19. USPS - United States Postal Service; www.usps.com.

D. Standards and Regulations: Where abbreviations and acronyms are used in Specifications or other Contract Documents, they shall mean the recognized name of the standards and regulations in the following list. This information is subject to change and is believed to be accurate as of the date of the Contract Documents.

1. CFR - Code of Federal Regulations; Available from Government Printing Office; www.gpo.gov/fdsys.
2. DOD - Department of Defense; Military Specifications and Standards; Available from Department of Defense Single Stock Point; <http://dodssp.daps.dla.mil>.
3. DSCC - Defense Supply Center Columbus; (See FS).
4. FED-STD - Federal Standard; (See FS).
5. FS - Federal Specification; Available from Department of Defense Single Stock Point; <http://dodssp.daps.dla.mil>.
 - a. Available from Defense Standardization Program; www.dsp.dla.mil.
 - b. Available from General Services Administration; www.gsa.gov.
 - c. Available from National Institute of Building Sciences/Whole Building Design Guide; www.wbdg.org/ccb.
6. MILSPEC - Military Specification and Standards; (See DOD).
7. USAB - United States Access Board; www.access-board.gov.
8. USATBCB - U.S. Architectural & Transportation Barriers Compliance Board; (See USAB).

E. State Government Agencies: Where abbreviations and acronyms are used in Specifications or other Contract Documents, they shall mean the recognized name of the entities in the following list. This information is subject to change and is believed to be accurate as of the date of the Contract Documents.

1. MDEP - State of Maine Department of Environmental Protection.
2. MDOT - State of Maine Department of Transportation

BURBANK BRANCH RENOVATIONS, PORTLAND PUBLIC LIBRARY

PART 2 - PRODUCTS (Not Used)

PART 3 - EXECUTION (Not Used)

END OF SECTION 014200

SECTION 015000 - TEMPORARY FACILITIES AND CONTROLS

PART 1 - GENERAL

1.1 RELATED DOCUMENTS

- A. Drawings and general provisions of the Contract, including General and Supplementary Conditions and other Division 01 Specification Sections, apply to this Section.

1.2 SUMMARY

- A. Section includes requirements for temporary utilities, support facilities, and security and protection facilities.
- B. Related Requirements:
 - 1. Section 011000 "Summary" for work restrictions and limitations on utility interruptions.

1.3 USE CHARGES

- A. General: Installation and removal of and use charges for temporary facilities shall be included in the Contract Sum unless otherwise indicated. Allow other entities to use temporary services and facilities without cost, including, but not limited to, Architect, testing agencies, and authorities having jurisdiction.
- B. Water and Sewer Service from Existing System: Water from Owner's existing water system is available for use without metering and without payment of use charges. Provide connections and extensions of services as required for construction operations.
- C. Electric Power Service from Existing System: Electric power from Owner's existing system is available for use without metering and without payment of use charges. Provide connections and extensions of services as required for construction operations.
- D. Heating Fuel: Fuel required for temporary heating will be the responsibility of the Contractor.
- E. Telephone Service: Pay service and use charges for telephone usage, by Contractor, at Project site.

1.4 INFORMATIONAL SUBMITTALS

- A. Moisture-Protection Plan: Describe procedures and controls for protecting materials and construction from water absorption and damage.
 - 1. Describe delivery, handling, and storage provisions for materials subject to water absorption or water damage.

BURBANK BRANCH RENOVATIONS, PORTLAND PUBLIC LIBRARY

2. Indicate procedures for discarding water-damaged materials, protocols for mitigating water intrusion into completed Work, and replacing water-damaged Work.
 3. Indicate sequencing of work that requires water, such as sprayed fire-resistive materials, plastering, and terrazzo grinding, and describe plans for dealing with water from these operations. Show procedures for verifying that wet construction has dried sufficiently to permit installation of finish materials.
- B. Dust- and HVAC-Control Plan: Submit coordination drawing and narrative that indicates the dust- and HVAC-control measures proposed for use, proposed locations, and proposed time frame for their operation. Identify further options if proposed measures are later determined to be inadequate. Include the following:
1. Locations of dust-control partitions at each phase of work.
 2. HVAC system isolation schematic drawing.
 3. Location of proposed air-filtration system discharge.
 4. Waste handling procedures.
 5. Other dust-control measures.

1.5 QUALITY ASSURANCE

- A. Electric Service: Comply with NECA, NEMA, and UL standards and regulations for temporary electric service. Install service to comply with NFPA 70.
- B. Tests and Inspections: Arrange for authorities having jurisdiction to test and inspect each temporary utility before use. Obtain required certifications and permits.
- C. Accessible Temporary Egress: Comply with applicable provisions in the U.S. Architectural & Transportation Barriers Compliance Board's ADA-ABA Accessibility Guidelines.

1.6 PROJECT CONDITIONS

- A. Temporary Use of Permanent Facilities: Engage Installer of each permanent service to assume responsibility for operation, maintenance, and protection of each permanent service during its use as a construction facility before Owner's acceptance, regardless of previously assigned responsibilities.

PART 2 - PRODUCTS

2.1 MATERIALS

- A. Lumber and Plywood: Comply with requirements in Division 06 Section "Rough Carpentry."
- B. Gypsum Board: Minimum 1/2 inch thick by 48 inches wide by maximum available lengths; regular-type panels with tapered edges. Comply with ASTM C 36/C 36M.
- C. Polyethylene Sheet: Reinforced, fire-resistive sheet, 10-mil minimum thickness, with flame-spread rating of 15 or less per ASTM E 84 and passing NFPA 701 Test Method 2.

BURBANK BRANCH RENOVATIONS, PORTLAND PUBLIC LIBRARY

- D. Dust-Control Adhesive-Surface Walk-off Mats: Provide mats minimum 36 by 60 inches.
- E. Insulation: Unfaced mineral-fiber blanket, manufactured from glass, slag wool, or rock wool; with maximum flame-spread and smoke-developed indexes of 25 and 50, respectively.

2.2 TEMPORARY FACILITIES

- A. Common-Use Field Office: Not required.
- B. Storage and Fabrication Sheds: Provide sheds sized, furnished, and equipped to accommodate materials and equipment for construction operations.
 - 1. Store combustible materials apart from building.

2.3 EQUIPMENT

- A. Fire Extinguishers: Portable, UL rated; with class and extinguishing agent as required by locations and classes of fire exposures.
- B. Air-Filtration Units: Primary and secondary HEPA-filter-equipped portable units with four-stage filtration. Provide single switch for emergency shutoff. Configure to run continuously.

PART 3 - EXECUTION

3.1 INSTALLATION, GENERAL

- A. Locate facilities where they will serve Project adequately and result in minimum interference with performance of the Work. Relocate and modify facilities as required by progress of the Work.
 - 1. Locate facilities to limit site disturbance as specified in Section 011000 "Summary."
- B. Provide each facility ready for use when needed to avoid delay. Do not remove until facilities are no longer needed or are replaced by authorized use of completed permanent facilities.

3.2 TEMPORARY UTILITY INSTALLATION

- A. General: Install temporary service or connect to existing service.
 - 1. Arrange with utility company, Owner, and existing users for time when service can be interrupted, if necessary, to make connections for temporary services.
- B. Water Service: Connect to Owner's existing water service facilities. Clean and maintain water service facilities in a condition acceptable to Owner. At Substantial Completion, restore these facilities to condition existing before initial use.

BURBANK BRANCH RENOVATIONS, PORTLAND PUBLIC LIBRARY

- C. Sanitary Facilities: Provide temporary toilets, wash facilities, and drinking water for use of construction personnel. Comply with requirements of authorities having jurisdiction for type, number, location, operation, and maintenance of fixtures and facilities.
 - 1. Toilets: Use of Owner's existing toilet facilities will be permitted, as long as facilities are cleaned and maintained in a condition acceptable to Owner. At Substantial Completion, restore these facilities to condition existing before initial use.
- D. Heating: Provide temporary heating required by construction activities for curing or drying of completed installations or for protecting installed construction from adverse effects of low temperatures or high humidity. Owner will provide a full fuel tank at the start of construction. Contractor will re-fill fuel tank at Final Completion.
 - 1. Maintain a minimum temperature of 50 deg F in permanently enclosed portions of building for normal construction activities, and 65 deg F for finishing activities and areas where finished Work has been installed.
 - a. Refer to Divisions 02 through 48 for additional temporary heat, ventilation, and humidity requirements for products in those Sections.”
- E. Isolation of Work Areas in Occupied Facilities: Prevent dust, fumes, and odors from entering occupied areas.
 - 1. Prior to commencing work, isolate the HVAC system in area where work is to be performed according to coordination drawings.
 - a. Disconnect supply and return ductwork in work area from HVAC systems servicing occupied areas.
 - b. Maintain negative air pressure within work area using HEPA-equipped air-filtration units, starting with commencement of temporary partition construction, and continuing until removal of temporary partitions is complete.
 - 2. Maintain dust partitions during the Work. Use vacuum collection attachments on dust-producing equipment. Isolate limited work within occupied areas using portable dust-containment devices.
 - 3. Perform daily construction cleanup and final cleanup using approved, HEPA-filter-equipped vacuum equipment.
- F. Ventilation and Humidity Control: Provide temporary ventilation required by construction activities for curing or drying of completed installations or for protecting installed construction from adverse effects of high humidity. Select equipment that will not have a harmful effect on completed installations or elements being installed. Coordinate ventilation requirements to produce ambient condition required and minimize energy consumption.
 - 1. Provide dehumidification systems when required to reduce substrate moisture levels to level required to allow installation or application of finishes.
 - 2. It shall be the General Contractor's responsibility to provide dehumidifiers or humidifiers required to perform the installation of wood floors.
- G. Electric Power Service: Connect to Owner's existing electric power service. Maintain equipment in a condition acceptable to Owner.

BURBANK BRANCH RENOVATIONS, PORTLAND PUBLIC LIBRARY

- H. Lighting: Provide temporary lighting with local switching that provides adequate illumination for construction operations, observations, inspections, and traffic conditions.
 - 1. Install and operate temporary lighting that fulfills security and protection requirements without operating entire system.
- I. Telephone Service: Provide temporary telephone service in common-use facilities for use by all construction personnel.
 - 1. At each telephone, post a list of important telephone numbers.
 - a. Police and fire departments.
 - b. Ambulance service.
 - c. Contractor's home office.
 - d. Contractor's emergency after-hours telephone number.
 - e. Architect's office.
 - f. Engineers' offices.
 - g. Owner's office.
 - h. Principal subcontractors' field and home offices.
 - 2. Provide an answering service on superintendent's telephone.

3.3 SUPPORT FACILITIES INSTALLATION

- A. General: Comply with the following:
 - 1. Provide construction for temporary sheds located within construction area or within 30 feet of building lines that is noncombustible according to ASTM E 136. Comply with NFPA 241.
 - 2. Maintain support facilities until Architect schedules Substantial Completion inspection. Remove before Substantial Completion. Personnel remaining after Substantial Completion will be permitted to use permanent facilities, under conditions acceptable to Owner.
- B. Traffic Controls: Comply with requirements of authorities having jurisdiction.
 - 1. Protect existing site improvements to remain including curbs, pavement, and utilities.
 - 2. Maintain access for fire-fighting equipment and access to fire hydrants.
- C. Parking: Use designated areas of Owner's existing parking areas for construction personnel.
- D. Dewatering Facilities and Drains: Comply with requirements of authorities having jurisdiction. Maintain Project site, excavations, and construction free of water.
 - 1. Dispose of rainwater in a lawful manner that will not result in flooding Project or adjoining properties or endanger permanent Work or temporary facilities.
 - 2. Remove snow and ice as required to minimize accumulations.

BURBANK BRANCH RENOVATIONS, PORTLAND PUBLIC LIBRARY

- E. Project Identification and Temporary Signs: Prepare Project identification and other signs in sizes indicated. Install signs where indicated to inform public and persons seeking entrance to Project. Do not permit installation of unauthorized signs.
 - 1. Engage an experienced sign painter to apply graphics for Project identification signs. Comply with details indicated. Include name of project, and names of Owner, Architect and Contractor.
 - 2. Construct signs of exterior-type Grade B-B high-density concrete form overlay plywood in size of 4 by 8 feet and 3/4 inch thickness, unless otherwise indicated. Support on posts or framing of preservative-treated wood or steel.
 - 3. Paint sign panel and applied graphics with exterior-grade alkyd gloss enamel over exterior primer.
 - 4. Temporary Signs: Provide other signs as indicated and as required to inform public and individuals seeking entrance to Project.
 - a. Provide temporary, directional signs for construction personnel and visitors.
 - 5. Maintain and touchup signs so they are legible at all times.
- F. Waste Disposal Facilities: Provide waste-collection containers in sizes adequate to handle waste from construction operations. Comply with requirements of authorities having jurisdiction. Comply with progress cleaning requirements in Section 017300 "Execution."
- G. Lifts and Hoists: Provide facilities necessary for hoisting materials and personnel.
 - 1. Truck cranes and similar devices used for hoisting materials are considered "tools and equipment" and not temporary facilities.
- H. Temporary Elevator Use: Use of elevators is not permitted.
- I. Existing Stair Usage: Use of Owner's existing stairs will be permitted, provided stairs are cleaned and maintained in a condition acceptable to Owner. At Substantial Completion, restore stairs to condition existing before initial use.
 - 1. Provide protective coverings, barriers, devices, signs, or other procedures to protect stairs and to maintain means of egress. If stairs become damaged, restore damaged areas so no evidence remains of correction work.

3.4 SECURITY AND PROTECTION FACILITIES INSTALLATION

- A. Protection of Existing Facilities: Protect existing vegetation, equipment, structures, utilities, and other improvements at Project site and on adjacent properties, except those indicated to be removed or altered. Repair damage to existing facilities.
- B. Environmental Protection: Provide protection, operate temporary facilities, and conduct construction as required to comply with environmental regulations and that minimize possible air, waterway, and subsoil contamination or pollution or other undesirable effects.
 - 1. Comply with work restrictions specified in Section 011000 "Summary."

BURBANK BRANCH RENOVATIONS, PORTLAND PUBLIC LIBRARY

- C. Tree and Plant Protection: Install temporary fencing located as indicated or outside the drip line of trees to protect vegetation from damage from construction operations. Protect tree root systems from damage, flooding, and erosion.
- D. Temporary Enclosures: Provide temporary enclosures for protection of construction, in progress and completed, from exposure, foul weather, other construction operations, and similar activities. Provide temporary weathertight enclosure for building exterior.
 - 1. Where heating or cooling is needed and permanent enclosure is incomplete, insulate temporary enclosures.
- E. Temporary Fire Protection: Install and maintain temporary fire-protection facilities of types needed to protect against reasonably predictable and controllable fire losses. Comply with NFPA 241; manage fire-prevention program.
 - 1. Prohibit smoking in construction areas.
 - 2. Supervise welding operations, combustion-type temporary heating units, and similar sources of fire ignition according to requirements of authorities having jurisdiction.
 - 3. Develop and supervise an overall fire-prevention and -protection program for personnel at Project site. Review needs with local fire department and establish procedures to be followed. Instruct personnel in methods and procedures. Post warnings and information.

3.5 MOISTURE AND MOLD CONTROL

- A. Contractor's Moisture-Protection Plan: Avoid trapping water in finished work. Document visible signs of mold that may appear during construction.
- B. Exposed Construction Phase: Before installation of weather barriers, when materials are subject to wetting and exposure and to airborne mold spores, protect as follows:
 - 1. Protect porous materials from water damage.
 - 2. Protect stored and installed material from flowing or standing water.
 - 3. Keep porous and organic materials from coming into prolonged contact with concrete.
 - 4. Remove standing water from decks.
 - 5. Keep deck openings covered or dammed.
- C. Partially Enclosed Construction Phase: After installation of weather barriers but before full enclosure and conditioning of building, when installed materials are still subject to infiltration of moisture and ambient mold spores, protect as follows:
 - 1. Do not load or install drywall or other porous materials or components, or items with high organic content, into partially enclosed building.
 - 2. Keep interior spaces reasonably clean and protected from water damage.
 - 3. Periodically collect and remove waste containing cellulose or other organic matter.
 - 4. Discard or replace water-damaged material.
 - 5. Do not install material that is wet.
 - 6. Discard, replace, or clean stored or installed material that begins to grow mold.
 - 7. Perform work in a sequence that allows any wet materials adequate time to dry before enclosing the material in drywall or other interior finishes.

BURBANK BRANCH RENOVATIONS, PORTLAND PUBLIC LIBRARY

- D. Controlled Construction Phase of Construction: After completing and sealing of the building enclosure but prior to the full operation of permanent HVAC systems, maintain as follows:
1. Control moisture and humidity inside building by maintaining effective dry-in conditions.
 2. Use permanent HVAC system to control humidity.
 3. Comply with manufacturer's written instructions for temperature, relative humidity, and exposure to water limits.
 - a. Hygroscopic materials that may support mold growth, including wood and gypsum-based products, that become wet during the course of construction and remain wet for 48 hours are considered defective.
 - b. Measure moisture content of materials that have been exposed to moisture during construction operations or after installation. Record readings beginning at time of exposure and continuing daily for 48 hours. Identify materials containing moisture levels higher than allowed. Report findings in writing to Architect.
 - c. Remove materials that cannot be completely restored to their manufactured moisture level within 48 hours.

3.6 OPERATION, TERMINATION, AND REMOVAL

- A. Supervision: Enforce strict discipline in use of temporary facilities. To minimize waste and abuse, limit availability of temporary facilities to essential and intended uses.
- B. Maintenance: Maintain facilities in good operating condition until removal.
1. Maintain operation of temporary enclosures, heating, cooling, humidity control, ventilation, and similar facilities on a 24-hour basis where required to achieve indicated results and to avoid possibility of damage.
- C. Temporary Facility Changeover: Do not change over from using temporary security and protection facilities to permanent facilities until Substantial Completion.
- D. Termination and Removal: Remove each temporary facility when need for its service has ended, when it has been replaced by authorized use of a permanent facility, or no later than Substantial Completion. Complete or, if necessary, restore permanent construction that may have been delayed because of interference with temporary facility. Repair damaged Work, clean exposed surfaces, and replace construction that cannot be satisfactorily repaired.
1. Materials and facilities that constitute temporary facilities are property of Contractor. Owner reserves right to take possession of Project identification signs.
 2. At Substantial Completion, repair, renovate, and clean permanent facilities used during construction period. Comply with final cleaning requirements specified in Section 017700 "Closeout Procedures."

END OF SECTION 015000

SECTION 016000 - PRODUCT REQUIREMENTS

PART 1 - GENERAL

1.1 RELATED DOCUMENTS

- A. Drawings and general provisions of the Contract, including General and Supplementary Conditions and other Division 01 Specification Sections, apply to this Section.

1.2 SUMMARY

- A. Section includes administrative and procedural requirements for selection of products for use in Project; product delivery, storage, and handling; manufacturers' standard warranties on products; special warranties; and comparable products.
- B. Related Requirements:
 - 1. Section 012300 "Alternates" for products selected under an alternate.
 - 2. Section 012500 "Substitution Procedures" for requests for substitutions.
 - 3. Section 014200 "References" for applicable industry standards for products specified.

1.3 DEFINITIONS

- A. Products: Items obtained for incorporating into the Work, whether purchased for Project or taken from previously purchased stock. The term "product" includes the terms "material," "equipment," "system," and terms of similar intent.
 - 1. Named Products: Items identified by manufacturer's product name, including make or model number or other designation shown or listed in manufacturer's published product literature, that is current as of date of the Contract Documents.
 - 2. New Products: Items that have not previously been incorporated into another project or facility. Products salvaged or recycled from other projects are not considered new products.
- B. Substitutions: Changes in products, materials, equipment, and methods of construction from those required by the Contract Documents and proposed by Contractor.
- C. Basis-of-Design Product Specification: A specification in which a specific manufacturer's product is named and accompanied by the words "basis-of-design product," including make or model number or other designation, to establish the significant qualities related to type, function, dimension, in-service performance, physical properties, appearance, and other characteristics for purposes of evaluating comparable products of additional manufacturers named in the specification.

BURBANK BRANCH RENOVATIONS, PORTLAND PUBLIC LIBRARY

1.4 ACTION SUBMITTALS

- A. Basis-of-Design Product Specification Submittal: Comply with requirements in Section 013300 "Submittal Procedures." Show compliance with requirements.

1.5 QUALITY ASSURANCE

- A. Compatibility of Options: If Contractor is given option of selecting between two or more products for use on Project, select product compatible with products previously selected, even if previously selected products were also options.
 - 1. Each contractor is responsible for providing products and construction methods compatible with products and construction methods of other contractors.
 - 2. If a dispute arises between contractors over concurrently selectable but incompatible products, Architect will determine which products shall be used.
- B. Products with asbestos: Asbestos containing materials are not to be purchased or installed in this project.

1.6 PRODUCT DELIVERY, STORAGE, AND HANDLING

- A. Deliver, store, and handle products using means and methods that will prevent damage, deterioration, and loss, including theft and vandalism. Comply with manufacturer's written instructions.
- B. Delivery and Handling:
 - 1. Schedule delivery to minimize long-term storage at Project site and to prevent overcrowding of construction spaces.
 - 2. Coordinate delivery with installation time to ensure minimum holding time for items that are flammable, hazardous, easily damaged, or sensitive to deterioration, theft, and other losses.
 - 3. Deliver products to Project site in an undamaged condition in manufacturer's original sealed container or other packaging system, complete with labels and instructions for handling, storing, unpacking, protecting, and installing.
 - 4. Inspect products on delivery to determine compliance with the Contract Documents and to determine that products are undamaged and properly protected.
- C. Storage:
 - 1. Store products to allow for inspection and measurement of quantity or counting of units.
 - 2. Store materials in a manner that will not endanger Project structure.
 - 3. Store products that are subject to damage by the elements, under cover in a weathertight enclosure above ground, with ventilation adequate to prevent condensation.
 - 4. Protect foam plastic from exposure to sunlight, except to extent necessary for period of installation and concealment.
 - 5. Comply with product manufacturer's written instructions for temperature, humidity, ventilation, and weather-protection requirements for storage.
 - 6. Protect stored products from damage and liquids from freezing.

1.7 PRODUCT WARRANTIES

- A. Warranties specified in other Sections shall be in addition to, and run concurrent with, other warranties required by the Contract Documents. Manufacturer's disclaimers and limitations on product warranties do not relieve Contractor of obligations under requirements of the Contract Documents.
 - 1. Manufacturer's Warranty: Written warranty furnished by individual manufacturer for a particular product and specifically endorsed by manufacturer to Owner.
 - 2. Special Warranty: Written warranty required by the Contract Documents to provide specific rights for Owner.
- B. Special Warranties: Prepare a written document that contains appropriate terms and identification, ready for execution.
 - 1. Manufacturer's Standard Form: Modified to include Project-specific information and properly executed.
 - 2. Specified Form: When specified forms are included with the Specifications, prepare a written document using indicated form properly executed.
 - 3. See other Sections for specific content requirements and particular requirements for submitting special warranties.
- C. Submittal Time: Comply with requirements in Section 017700 "Closeout Procedures."

PART 2 - PRODUCTS

2.1 PRODUCT SELECTION PROCEDURES

- A. General Product Requirements: Provide products that comply with the Contract Documents, are undamaged and, unless otherwise indicated, are new at time of installation.
 - 1. Provide products complete with accessories, trim, finish, fasteners, and other items needed for a complete installation and indicated use and effect.
 - 2. Standard Products: If available, and unless custom products or nonstandard options are specified, provide standard products of types that have been produced and used successfully in similar situations on other projects.
 - 3. Owner reserves the right to limit selection to products with warranties not in conflict with requirements of the Contract Documents.
 - 4. Where products are accompanied by the term "as selected," Architect will make selection.
 - 5. Descriptive, performance, and reference standard requirements in the Specifications establish salient characteristics of products.
 - 1. Or Equal: Where products are specified by name and accompanied by the term "or equal" or "or approved equal" or "or approved substitute" or approved," comply with provisions in "Product Substitutions" Article to obtain approval for use of an unnamed product.
- B. Product Selection Procedures:

BURBANK BRANCH RENOVATIONS, PORTLAND PUBLIC LIBRARY

1. **Product:** Where Specifications name a single manufacturer and product, provide the named product that complies with requirements. Substitutions for Contractor's convenience will not be considered.
 2. **Manufacturer/Source:** Where Specifications name a single manufacturer or source, provide a product by the named manufacturer or source that complies with requirements. Substitutions for Contractor's convenience will not be considered.
 3. **Products:**
 - a. **Restricted List:** Where Specifications include a list of names of both manufacturers and products, provide one of the products listed that complies with requirements. Substitutions for Contractor's convenience will be considered, unless otherwise indicated.
 - b. **Nonrestricted List:** Where Specifications include a list of names of both available manufacturers and products, provide one of the products listed, or an unnamed product, that complies with requirements. Comply with requirements in Division 01 Section "Substitution Procedures" for consideration of an unnamed product.
 4. **Manufacturers:**
 - a. **Restricted List:** Where Specifications include a list of manufacturers' names, provide a product by one of the manufacturers listed that complies with requirements. Comparable products or substitutions for Contractor's convenience will be considered, unless otherwise indicated.
 - b. **Nonrestricted List:** Where Specifications include a list of available manufacturers, provide a product by one of the manufacturers listed, or a product by an unnamed manufacturer, that complies with requirements. Comply with requirements in Division 01 Section "Substitution Procedures" for consideration of an unnamed manufacturer.
 5. **Basis-of-Design Product:** Where Specifications name a product, or refer to a product indicated on Drawings, and include a list of manufacturers, provide the specified or indicated product or a comparable product by one of the other named manufacturers. Drawings and Specifications indicate sizes, profiles, dimensions, and other characteristics that are based on the product named. Comply with requirements in Division 01 Section "Substitution Procedures" for consideration of an unnamed product or manufacturer.
- C. **Visual Matching Specification:** Where Specifications require "match Architect's sample", provide a product that complies with requirements and matches Architect's sample. Architect's decision will be final on whether a proposed product matches.
1. If no product available within specified category matches and complies with other specified requirements, comply with requirements in Section 012500 "Substitution Procedures" for proposal of product.
- D. **Visual Selection Specification:** Where Specifications include the phrase "as selected by Architect from manufacturer's full range" or similar phrase, select a product that complies with requirements. Architect will select color, gloss, pattern, density, or texture from manufacturer's product line that includes both standard and premium items.

BURBANK BRANCH RENOVATIONS, PORTLAND PUBLIC LIBRARY

PART 3 - EXECUTION (Not Used)

END OF SECTION 016000

SECTION 017300 - EXECUTION

PART 1 - GENERAL

1.1 RELATED DOCUMENTS

- A. Drawings and general provisions of the Contract, including General and Supplementary Conditions and other Division 01 Specification Sections, apply to this Section.

1.2 SUMMARY

- A. Section includes general administrative and procedural requirements governing execution of the Work including, but not limited to, the following:
 1. Installation of the Work.
 2. Cutting and patching.
 3. Progress cleaning.
 4. Starting and adjusting.
 5. Protection of installed construction.

1.3 DEFINITIONS

- A. Cutting: Removal of in-place construction necessary to permit installation or performance of other work.
- B. Patching: Fitting and repair work required to restore construction to original conditions after installation of other work.

1.4 QUALITY ASSURANCE

- A. Cutting and Patching: Comply with requirements for and limitations on cutting and patching of construction elements.
 1. Structural Elements: When cutting and patching structural elements, notify Architect of locations and details of cutting and await directions from Architect before proceeding. Shore, brace, and support structural elements during cutting and patching. Do not cut and patch structural elements in a manner that could change their load-carrying capacity or increase deflection
 2. Operational Elements: Do not cut and patch operating elements and related components in a manner that results in reducing their capacity to perform as intended or that results in increased maintenance or decreased operational life or safety.
 3. Other Construction Elements: Do not cut and patch other construction elements or components in a manner that could change their load-carrying capacity, that results in reducing their capacity to perform as intended, or that results in increased maintenance or decreased operational life or safety.
 4. Visual Elements: Do not cut and patch construction in a manner that results in visual evidence of cutting and patching. Do not cut and patch exposed construction in a manner

BURBANK BRANCH RENOVATIONS, PORTLAND PUBLIC LIBRARY

that would, in Architect's opinion, reduce the building's aesthetic qualities. Remove and replace construction that has been cut and patched in a visually unsatisfactory manner.

- B. Cutting and Patching Conference: Before proceeding, meet at Project site with parties involved in cutting and patching, including mechanical and electrical trades. Review areas of potential interference and conflict. Coordinate procedures and resolve potential conflicts before proceeding.
- C. Manufacturer's Installation Instructions: Obtain and maintain on-site manufacturer's written recommendations and instructions for installation of products and equipment.

PART 2 - PRODUCTS

2.1 MATERIALS

- A. General: Comply with requirements specified in other Sections.
- B. In-Place Materials: Use materials for patching identical to in-place materials. For exposed surfaces, use materials that visually match in-place adjacent surfaces to the fullest extent possible.
 - 1. If identical materials are unavailable or cannot be used, use materials that, when installed, will provide a match acceptable to Architect for the visual and functional performance of in-place materials.

PART 3 - EXECUTION

3.1 EXAMINATION

- A. Existing Conditions: The existence and location of underground and other utilities and construction indicated as existing are not guaranteed. Before beginning sitework, investigate and verify the existence and location of underground utilities, mechanical and electrical systems, and other construction affecting the Work.
 - 1. Before construction, verify the location and invert elevation at points of connection of sanitary sewer, storm sewer, and water-service piping; underground electrical services, and other utilities.
 - 2. Furnish location data for work related to Project that must be performed by public utilities serving Project site.
- B. Examination and Acceptance of Conditions: Before proceeding with each component of the Work, examine substrates, areas, and conditions, with Installer or Applicator present where indicated, for compliance with requirements for installation tolerances and other conditions affecting performance. Record observations.
 - 1. Examine roughing-in for mechanical and electrical systems to verify actual locations of connections before equipment and fixture installation.

BURBANK BRANCH RENOVATIONS, PORTLAND PUBLIC LIBRARY

2. Examine walls, floors, and roofs for suitable conditions where products and systems are to be installed.
 3. Verify compatibility with and suitability of substrates, including compatibility with existing finishes or primers.
- C. Written Report: Where a written report listing conditions detrimental to performance of the Work is required by other Sections, include the following:
1. Description of the Work.
 2. List of detrimental conditions, including substrates.
 3. List of unacceptable installation tolerances.
 4. Recommended corrections.
- D. Proceed with installation only after unsatisfactory conditions have been corrected. Proceeding with the Work indicates acceptance of surfaces and conditions.

3.2 PREPARATION

- A. Existing Utility Information: Furnish information to Owner that is necessary to adjust, move, or relocate existing utility structures, utility poles, lines, services, or other utility appurtenances located in or affected by construction. Coordinate with authorities having jurisdiction.
- B. Field Measurements: Take field measurements as required to fit the Work properly. Recheck measurements before installing each product. Where portions of the Work are indicated to fit to other construction, verify dimensions of other construction by field measurements before fabrication. Coordinate fabrication schedule with construction progress to avoid delaying the Work.
- C. Space Requirements: Verify space requirements and dimensions of items shown diagrammatically on Drawings.
- D. Review of Contract Documents and Field Conditions: Immediately on discovery of the need for clarification of the Contract Documents caused by differing field conditions outside the control of Contractor, submit a request for information to Architect according to requirements in Section 013100 "Project Management and Coordination."

3.3 INSTALLATION

- A. General: Locate the Work and components of the Work accurately, in correct alignment and elevation, as indicated.
1. Make vertical work plumb and make horizontal work level.
 2. Where space is limited, install components to maximize space available for maintenance and ease of removal for replacement.
 3. Conceal pipes, ducts, and wiring in finished areas unless otherwise indicated.
- B. Comply with manufacturer's written instructions and recommendations for installing products in applications indicated.

BURBANK BRANCH RENOVATIONS, PORTLAND PUBLIC LIBRARY

- C. Install products at the time and under conditions that will ensure the best possible results. Maintain conditions required for product performance until Substantial Completion.
- D. Conduct construction operations so no part of the Work is subjected to damaging operations or loading in excess of that expected during normal conditions of occupancy.
- E. Sequence the Work and allow adequate clearances to accommodate movement of construction items on site and placement in permanent locations.
- F. Tools and Equipment: Do not use tools or equipment that produce harmful noise levels.
- G. Templates: Obtain and distribute to the parties involved templates for work specified to be factory prepared and field installed. Check Shop Drawings of other work to confirm that adequate provisions are made for locating and installing products to comply with indicated requirements.
- H. Attachment: Provide blocking and attachment plates and anchors and fasteners of adequate size and number to securely anchor each component in place, accurately located and aligned with other portions of the Work. Where size and type of attachments are not indicated, verify size and type required for load conditions.
 - 1. Mounting Heights: Where mounting heights are not indicated, mount components at heights directed by Architect.
 - 2. Allow for building movement, including thermal expansion and contraction.
 - 3. Coordinate installation of anchorages. Furnish setting drawings, templates, and directions for installing anchorages, including sleeves, concrete inserts, anchor bolts, and items with integral anchors, that are to be embedded in concrete or masonry. Deliver such items to Project site in time for installation.
- I. Joints: Make joints of uniform width. Where joint locations in exposed work are not indicated, arrange joints for the best visual effect. Fit exposed connections together to form hairline joints.
- J. Hazardous Materials: Use products, cleaners, and installation materials that are not considered hazardous.

3.4 CUTTING AND PATCHING

- A. Cutting and Patching, General: Employ skilled workers to perform cutting and patching. Proceed with cutting and patching at the earliest feasible time, and complete without delay.
 - 1. Cut in-place construction to provide for installation of other components or performance of other construction, and subsequently patch as required to restore surfaces to their original condition.
- B. Existing Warranties: Remove, replace, patch, and repair materials and surfaces cut or damaged during installation or cutting and patching operations, by methods and with materials so as not to void existing warranties.
- C. Temporary Support: Provide temporary support of work to be cut.

BURBANK BRANCH RENOVATIONS, PORTLAND PUBLIC LIBRARY

- D. Protection: Protect in-place construction during cutting and patching to prevent damage. Provide protection from adverse weather conditions for portions of Project that might be exposed during cutting and patching operations.
- E. Adjacent Occupied Areas: Where interference with use of adjoining areas or interruption of free passage to adjoining areas is unavoidable, coordinate cutting and patching according to requirements in Section 011000 "Summary."
- F. Existing Utility Services and Mechanical/Electrical Systems: Where existing services/systems are required to be removed, relocated, or abandoned, bypass such services/systems before cutting to minimize interruption to occupied areas.
- G. Cutting: Cut in-place construction by sawing, drilling, breaking, chipping, grinding, and similar operations, including excavation, using methods least likely to damage elements retained or adjoining construction. If possible, review proposed procedures with original Installer; comply with original Installer's written recommendations.
 - 1. In general, use hand or small power tools designed for sawing and grinding, not hammering and chopping. Cut holes and slots neatly to minimum size required, and with minimum disturbance of adjacent surfaces. Temporarily cover openings when not in use.
 - 2. Finished Surfaces: Cut or drill from the exposed or finished side into concealed surfaces.
 - 3. Concrete and Masonry: Cut using a cutting machine, such as an abrasive saw or a diamond-core drill.
 - 4. Excavating and Backfilling: Comply with requirements in applicable Sections where required by cutting and patching operations.
 - 5. Mechanical and Electrical Services: Cut off pipe or conduit in walls or partitions to be removed. Cap, valve, or plug and seal remaining portion of pipe or conduit to prevent entrance of moisture or other foreign matter after cutting.
 - 6. Proceed with patching after construction operations requiring cutting are complete.
- H. Patching: Patch construction by filling, repairing, refinishing, closing up, and similar operations following performance of other work. Patch with durable seams that are as invisible as practicable. Provide materials and comply with installation requirements specified in other Sections, where applicable.
 - 1. Inspection: Where feasible, test and inspect patched areas after completion to demonstrate physical integrity of installation.
 - 2. Exposed Finishes: Restore exposed finishes of patched areas and extend finish restoration into retained adjoining construction in a manner that will minimize evidence of patching and refinishing.
 - a. Clean piping, conduit, and similar features before applying paint or other finishing materials.
 - b. Restore damaged pipe covering to its original condition.
 - 3. Floors and Walls: Where walls or partitions that are removed extend one finished area into another, patch and repair floor and wall surfaces in the new space. Provide an even surface of uniform finish, color, texture, and appearance. Remove in-place floor and wall coverings and replace with new materials, if necessary, to achieve uniform color and appearance.

BURBANK BRANCH RENOVATIONS, PORTLAND PUBLIC LIBRARY

- a. Where patching occurs in a painted surface, prepare substrate and apply primer and intermediate paint coats appropriate for substrate over the patch, and apply final paint coat over entire unbroken surface containing the patch. Provide additional coats until patch blends with adjacent surfaces.
4. Ceilings: Patch, repair, or rehang in-place ceilings as necessary to provide an even-plane surface of uniform appearance.
5. Exterior Building Enclosure: Patch components in a manner that restores enclosure to a weathertight condition and ensures thermal and moisture integrity of building enclosure.
- I. Cleaning: Clean areas and spaces where cutting and patching are performed. Remove paint, mortar, oils, putty, and similar materials from adjacent finished surfaces.

3.5 PROGRESS CLEANING

- A. General: Clean Project site and work areas daily, including common areas. Enforce requirements strictly. Dispose of materials lawfully.
 1. Comply with requirements in NFPA 241 for removal of combustible waste materials and debris.
 2. Do not hold waste materials more than seven days during normal weather or three days if the temperature is expected to rise above 80 deg F.
 3. Containerize hazardous and unsanitary waste materials separately from other waste. Mark containers appropriately and dispose of legally, according to regulations.
 - a. Use containers intended for holding waste materials of type to be stored.
 4. Coordinate progress cleaning for joint-use areas where Contractor and other contractors are working concurrently.
- B. Site: Maintain Project site free of waste materials and debris.
- C. Work Areas: Clean areas where work is in progress to the level of cleanliness necessary for proper execution of the Work.
 1. Remove liquid spills promptly.
 2. Where dust would impair proper execution of the Work, broom-clean or vacuum the entire work area, as appropriate.
- D. For general construction, each trade shall pick up the debris and rubbish, generated by that trade, and dispose of in dumpsters furnished by the General Contractor.
- E. Installed Work: Keep installed work clean. Clean installed surfaces according to written instructions of manufacturer or fabricator of product installed, using only cleaning materials specifically recommended. If specific cleaning materials are not recommended, use cleaning materials that are not hazardous to health or property and that will not damage exposed surfaces.
- F. Concealed Spaces: Remove debris from concealed spaces before enclosing the space.

BURBANK BRANCH RENOVATIONS, PORTLAND PUBLIC LIBRARY

- G. Exposed Surfaces in Finished Areas: Clean exposed surfaces and protect as necessary to ensure freedom from damage and deterioration at time of Substantial Completion.
- H. Waste Disposal: Do not bury or burn waste materials on-site. Do not wash waste materials down sewers or into waterways. Comply with waste disposal requirements in Section 015000 "Temporary Facilities and Controls."
- I. During handling and installation, clean and protect construction in progress and adjoining materials already in place. Apply protective covering where required to ensure protection from damage or deterioration at Substantial Completion.
- J. Clean and provide maintenance on completed construction as frequently as necessary through the remainder of the construction period. Adjust and lubricate operable components to ensure operability without damaging effects.
- K. Limiting Exposures: Supervise construction operations to assure that no part of the construction, completed or in progress, is subject to harmful, dangerous, damaging, or otherwise deleterious exposure during the construction period.

3.6 STARTING AND ADJUSTING

- A. Coordinate startup and adjusting of equipment and operating components with requirements in Section 019113 "General Commissioning Requirements."
- B. Start equipment and operating components to confirm proper operation. Remove malfunctioning units, replace with new units, and retest.
- C. Adjust equipment for proper operation. Adjust operating components for proper operation without binding.
- D. Test each piece of equipment to verify proper operation. Test and adjust controls and safeties. Replace damaged and malfunctioning controls and equipment.
- E. Manufacturer's Field Service: Comply with qualification requirements in Section 014000 "Quality Requirements."

3.7 PROTECTION OF INSTALLED CONSTRUCTION

- A. Provide final protection and maintain conditions that ensure installed Work is without damage or deterioration at time of Substantial Completion.
- B. Comply with manufacturer's written instructions for temperature and relative humidity.
- C. Protect resilient flooring against mars, marks, indentations, and other damage from construction operations and placement of equipment and fixtures during the remainder of construction period. Use protection methods indicated or recommended in writing by flooring manufacturer.
 - 1. Cover products installed on floor surfaces with undyed, untreated building paper until inspection for Substantial Completion.

BURBANK BRANCH RENOVATIONS, PORTLAND PUBLIC LIBRARY

2. Do not move heavy and sharp objects directly over floor surfaces. Place plywood or hardboard panels over flooring and under objects while they are being moved. Slide or roll objects over panels without moving panels.
- D. Protect roofing materials against cuts, marks, indentations, and other damage from construction operations and placement of equipment and fixtures during the remainder of construction period.
1. Do not move heavy and sharp objects directly over roof surfaces. Place plywood or hardboard panels over roofing and under objects while they are being moved. Slide or roll objects over panels without moving panels.

END OF SECTION 017300

SECTION 017419 - CONSTRUCTION WASTE MANAGEMENT AND DISPOSAL

PART 1 - GENERAL

1.1 RELATED DOCUMENTS

- A. Drawings and general provisions of the Contract, including General and Supplementary Conditions and Division 01 Specification Sections, apply to this Section.

1.2 SUMMARY

- A. This Section includes administrative and procedural requirements for the following:
 - 1. Recycling nonhazardous demolition and construction waste.
 - 2. Disposing of nonhazardous demolition and construction waste.

1.3 DEFINITIONS

- A. Construction Waste: Building and site improvement materials and other solid waste resulting from construction, remodeling, renovation, or repair operations. Construction waste includes packaging.
- B. Demolition Waste: Building and site improvement materials resulting from demolition or selective demolition operations.
- C. Disposal: Removal off-site of demolition and construction waste and subsequent sale, recycling, reuse, or deposit in landfill or incinerator acceptable to authorities having jurisdiction.
- D. Recycle: Recovery of demolition or construction waste for subsequent processing in preparation for reuse.
- E. Salvage: Recovery of demolition or construction waste and subsequent sale or reuse in another facility.
- F. Salvage and Reuse: Recovery of demolition or construction waste and subsequent incorporation into the Work.

1.4 PERFORMANCE REQUIREMENTS

- A. General: Salvage/recycle as much percent by weight as possible of total non-hazardous solid waste generated by the Work. Practice efficient waste management in the use of materials in the course of the Work. Use all reasonable means to divert construction and demolition waste from landfills and incinerators. Facilitate recycling and salvage of materials, including the following:
 - 1. Demolition Waste:

BURBANK BRANCH RENOVATIONS, PORTLAND PUBLIC LIBRARY

- a. Asphaltic concrete paving.
 - b. Concrete.
 - c. Concrete reinforcing steel.
 - d. Brick.
 - e. Concrete masonry units.
 - f. Wood studs.
 - g. Wood joists.
 - h. Plywood and oriented strand board.
 - i. Wood paneling.
 - j. Wood trim.
 - k. Structural and miscellaneous steel.
 - l. Rough hardware.
 - m. Roofing.
 - n. Insulation.
 - o. Doors and frames.
 - p. Door hardware.
 - q. Windows.
 - r. Glazing.
 - s. Gypsum board.
 - t. Equipment.
 - u. Cabinets.
 - v. Piping.
 - w. Supports and hangers.
 - x. Valves.
 - y. Sprinklers.
 - z. Mechanical equipment.
 - aa. Electrical conduit.
 - bb. Copper wiring.
 - cc. Switchgear and panelboards.
2. Construction Waste:
- a. Site-clearing waste.
 - b. Masonry and CMU.
 - c. Lumber.
 - d. Wood sheet materials.
 - e. Wood trim.
 - f. Metals.
 - g. Roofing.
 - h. Insulation.
 - i. Carpet and pad.
 - j. Gypsum board.
 - k. Piping.
 - l. Electrical conduit.
 - m. Packaging: Regardless of salvage/recycle goal indicated above, salvage or recycle 100 percent of the following uncontaminated packaging materials:
 - 1) Paper.
 - 2) Cardboard.
 - 3) Boxes.
 - 4) Plastic sheet and film.

BURBANK BRANCH RENOVATIONS, PORTLAND PUBLIC LIBRARY

- 5) Polystyrene packaging.
- 6) Wood crates.
- 7) Plastic pails.

1.5 QUALITY ASSURANCE

- A. Regulatory Requirements: Comply with hauling and disposal regulations of authorities having jurisdiction.

PART 2 - PRODUCTS (Not Used)

PART 3 - EXECUTION

3.1 SALVAGING DEMOLITION WASTE

A. Salvaged Items for Reuse in the Work:

1. Clean salvaged items.
2. Pack or crate items after cleaning. Identify contents of containers.
3. Store items in a secure area until installation.
4. Protect items from damage during transport and storage.
5. Install salvaged items to comply with installation requirements for new materials and equipment. Provide connections, supports, and miscellaneous materials necessary to make items functional for use indicated.

B. Salvaged Items for Owner's Use:

1. Clean salvaged items.
2. Pack or crate items after cleaning. Identify contents of containers.
3. Store items in a secure area until delivery to Owner.
4. Transport items to Owner's storage area on-site.
5. Protect items from damage during transport and storage.

- C. Doors and Hardware: Brace open end of door frames. Except for removing door closers, leave door hardware attached to doors.

3.2 RECYCLING DEMOLITION AND CONSTRUCTION WASTE, GENERAL

- A. General: Recycle paper and beverage containers used by on-site workers.

- B. Procedures: Separate recyclable waste from other waste materials, trash, and debris. Separate recyclable waste by type at Project site to the maximum extent practical.

1. Provide appropriately marked containers or bins for controlling recyclable waste until they are removed from Project site. Include list of acceptable and unacceptable materials at each container and bin.

BURBANK BRANCH RENOVATIONS, PORTLAND PUBLIC LIBRARY

- a. Inspect containers and bins for contamination and remove contaminated materials if found.
2. Stockpile processed materials on-site without intermixing with other materials. Place, grade, and shape stockpiles to drain surface water. Cover to prevent windblown dust.
3. Stockpile materials away from construction area. Do not store within drip line of remaining trees.
4. Store components off the ground and protect from the weather.
5. Remove recyclable waste off Owner's property and transport to recycling receiver or processor.

3.3 RECYCLING DEMOLITION WASTE

- A. Concrete: Remove reinforcement and other metals from concrete and sort with other metals.
- B. Masonry: Remove metal reinforcement, anchors, and ties from masonry and sort with other metals.
 1. Clean and stack undamaged, whole masonry units on wood pallets.
- C. Wood Materials: Sort and stack members according to size, type, and length. Separate lumber, engineered wood products, panel products, and treated wood materials.
- D. Metals: Separate metals by type.
 1. Structural Steel: Stack members according to size, type of member, and length.
 2. Remove and dispose of bolts, nuts, washers, and other rough hardware.
- E. Gypsum Board: Stack large clean pieces on wood pallets and store in a dry location. Remove edge trim and sort with other metals. Remove and dispose of fasteners.
- F. Equipment: Drain tanks, piping, and fixtures. Seal openings with caps or plugs. Protect equipment from exposure to weather.
- G. Piping: Reduce piping to straight lengths and store by type and size. Separate supports, hangers, valves, sprinklers, and other components by type and size.
- H. Lighting Fixtures: Separate lamps by type and protect from breakage.
- I. Electrical Devices: Separate switches, receptacles, switchgear, transformers, meters, panelboards, circuit breakers, and other devices by type.
- J. Conduit: Reduce conduit to straight lengths and store by type and size.

3.4 RECYCLING CONSTRUCTION WASTE

- A. Packaging:
 1. Cardboard and Boxes: Break down packaging into flat sheets. Bundle and store in a dry location.

BURBANK BRANCH RENOVATIONS, PORTLAND PUBLIC LIBRARY

2. Polystyrene Packaging: Separate and bag materials.
3. Pallets: As much as possible, require deliveries using pallets to remove pallets from Project site. For pallets that remain on-site, break down pallets into component wood pieces and comply with requirements for recycling wood.
4. Crates: Break down crates into component wood pieces and comply with requirements for recycling wood.

B. Wood Materials:

1. Clean Cut-Offs of Lumber: Grind or chip into small pieces.
2. Clean Sawdust: Bag sawdust that does not contain painted or treated wood.

3.5 DISPOSAL OF WASTE

A. General: Except for items or materials to be salvaged, recycled, or otherwise reused, remove waste materials from Project site and legally dispose of them in a landfill or incinerator acceptable to authorities having jurisdiction.

1. Except as otherwise specified, do not allow waste materials that are to be disposed of accumulate on-site.
2. Remove and transport debris in a manner that will prevent spillage on adjacent surfaces and areas.

B. Burning: Do not burn waste materials.

C. Disposal: Transport waste materials off Owner's property and legally dispose of them.

END OF SECTION 017419

SECTION 017700 - CLOSEOUT PROCEDURES

PART 1 - GENERAL

1.1 RELATED DOCUMENTS

- A. Drawings and general provisions of the Contract, including General and Supplementary Conditions and other Division 01 Specification Sections, apply to this Section.

1.2 SUMMARY

- A. Section includes administrative and procedural requirements for contract closeout, including, but not limited to, the following:
 - 1. Substantial Completion procedures.
 - 2. Final completion procedures.
 - 3. Warranties.
 - 4. Final cleaning.
 - 5. Repair of the Work.
- B. Related Requirements:
 - 1. Section 017300 "Execution" for progress cleaning of Project site.
 - 2. Section 017823 "Operation and Maintenance Data" for operation and maintenance manual requirements.
 - 3. Section 017839 "Project Record Documents" for submitting record Drawings, record Specifications, and record Product Data.

1.3 ACTION SUBMITTALS

- A. Product Data: For cleaning agents.
- B. Contractor's List of Incomplete Items: Initial submittal at Substantial Completion.
- C. Certified List of Incomplete Items: Final submittal at Final Completion.

1.4 CLOSEOUT SUBMITTALS

- A. Certificates of Release: From authorities having jurisdiction.
- B. Certificate of Insurance: For continuing coverage.
- C. Field Report: For pest control inspection.

BURBANK BRANCH RENOVATIONS, PORTLAND PUBLIC LIBRARY

1.5 MAINTENANCE MATERIAL SUBMITTALS

- A. Schedule of Maintenance Material Items: For maintenance material submittal items specified in other Sections.

1.6 SUBSTANTIAL COMPLETION PROCEDURES

- A. Contractor's List of Incomplete Items: Prepare and submit a list of items to be completed and corrected (Contractor's punch list), indicating the value of each item on the list and reasons why the Work is incomplete.
- B. Submittals Prior to Substantial Completion: Complete the following a minimum of 10 days prior to requesting inspection for determining date of Substantial Completion. List items below that are incomplete at time of request.
 - 1. Certificates of Release: Obtain and submit releases from authorities having jurisdiction permitting Owner unrestricted use of the Work and access to services and utilities. Include occupancy permits, operating certificates, and similar releases.
 - 2. Submit closeout submittals specified in other Division 01 Sections, including project record documents, operation and maintenance manuals, final completion construction photographic documentation, damage or settlement surveys, property surveys, and similar final record information.
 - 3. Submit closeout submittals specified in individual Sections, including specific warranties, workmanship bonds, maintenance service agreements, final certifications, and similar documents.
 - 4. Submit maintenance material submittals specified in individual Sections, including tools, spare parts, extra materials, and similar items, and deliver to location designated by Architect. Label with manufacturer's name and model number where applicable.
 - a. Schedule of Maintenance Material Items: Prepare and submit schedule of maintenance material submittal items, including name and quantity of each item and name and number of related Specification Section. Obtain Architect's signature for receipt of submittals.
 - 5. Submit test/adjust/balance records.
 - 6. Submit changeover information related to Owner's occupancy, use, operation, and maintenance.
- C. Procedures Prior to Substantial Completion: Complete the following a minimum of 10 days prior to requesting inspection for determining date of Substantial Completion. List items below that are incomplete at time of request.
 - 1. Advise Owner of pending insurance changeover requirements.
 - 2. Make final changeover of permanent locks and deliver keys to Owner. Advise Owner's personnel of changeover in security provisions.
 - 3. Complete startup and testing of systems and equipment.
 - 4. Perform preventive maintenance on equipment used prior to Substantial Completion.
 - 5. Instruct Owner's personnel in operation, adjustment, and maintenance of products, equipment, and systems. Submit demonstration and training video recordings specified in Section 017900 "Demonstration and Training."

BURBANK BRANCH RENOVATIONS, PORTLAND PUBLIC LIBRARY

6. Advise Owner of changeover in heat and other utilities.
 7. Participate with Owner in conducting inspection and walkthrough with local emergency responders.
 8. Terminate and remove temporary facilities from Project site, along with mockups, construction tools, and similar elements.
 9. Complete final cleaning requirements, including touchup painting.
 10. Touch up and otherwise repair and restore marred exposed finishes to eliminate visual defects.
- D. Inspection: Submit a written request for inspection to determine Substantial Completion a minimum of 10 days prior to date the work will be completed and ready for final inspection and tests. On receipt of request, Architect will either proceed with inspection or notify Contractor of unfulfilled requirements. Architect will prepare the Certificate of Substantial Completion after inspection or will notify Contractor of items, either on Contractor's list or additional items identified by Architect, that must be completed or corrected before certificate will be issued.
1. Reinspection: Request reinspection when the Work identified in previous inspections as incomplete is completed or corrected.
 2. Results of completed inspection will form the basis of requirements for final completion.

1.7 FINAL COMPLETION PROCEDURES

- A. Submittals Prior to Final Completion: Before requesting final inspection for determining final completion, complete the following:
1. Submit a final Application for Payment according to Section 012900 "Payment Procedures."
 2. Certified List of Incomplete Items: Submit certified copy of Architect's Substantial Completion inspection list of items to be completed or corrected (punch list), endorsed and dated by Architect. Certified copy of the list shall state that each item has been completed or otherwise resolved for acceptance.
 3. Certificate of Insurance: Submit evidence of final, continuing insurance coverage complying with insurance requirements.
 4. Submit pest-control final inspection report.
- B. Inspection: Submit a written request for final inspection to determine acceptance a minimum of 10 days prior to date the work will be completed and ready for final inspection and tests. On receipt of request, Architect will either proceed with inspection or notify Contractor of unfulfilled requirements. Architect will prepare a final Certificate for Payment after inspection or will notify Contractor of construction that must be completed or corrected before certificate will be issued.
1. Reinspection: Request reinspection when the Work identified in previous inspections as incomplete is completed or corrected.

1.8 LIST OF INCOMPLETE ITEMS (PUNCH LIST)

- A. Organization of List: Include name and identification of each space and area affected by construction operations for incomplete items and items needing correction including, if necessary, areas disturbed by Contractor that are outside the limits of construction.
 - 1. Organize list of spaces in sequential order, starting with exterior areas first and proceeding from lowest floor to highest floor.
 - 2. Organize items applying to each space by major element, including categories for ceiling, individual walls, floors, equipment, and building systems.
 - 3. Include the following information at the top of each page:
 - a. Project name.
 - b. Date.
 - c. Name of Architect.
 - d. Name of Contractor.
 - e. Page number.
 - 4. Submit list of incomplete items in the following format:
 - a. PDF electronic file. Architect will return annotated file.

1.9 SUBMITTAL OF PROJECT WARRANTIES

- A. Time of Submittal: Submit written warranties on request of Architect for designated portions of the Work where commencement of warranties other than date of Substantial Completion is indicated, or when delay in submittal of warranties might limit Owner's rights under warranty.
- B. Partial Occupancy: Submit properly executed warranties within 15 days of completion of designated portions of the Work that are completed and occupied or used by Owner during construction period by separate agreement with Contractor.
- C. Organize warranty documents into an orderly sequence based on the table of contents of Project Manual.
 - 1. Bind warranties and bonds in heavy-duty, three-ring, vinyl-covered, loose-leaf binders, thickness as necessary to accommodate contents, and sized to receive 8-1/2-by-11-inch paper.
 - 2. Provide heavy paper dividers with plastic-covered tabs for each separate warranty. Mark tab to identify the product or installation. Provide a typed description of the product or installation, including the name of the product and the name, address, and telephone number of Installer.
 - 3. Identify each binder on the front and spine with the typed or printed title "WARRANTIES," Project name, and name of Contractor.
 - 4. Warranty Electronic File: Scan warranties and bonds and assemble complete warranty and bond submittal package into a single indexed electronic PDF file with links enabling navigation to each item. Provide bookmarked table of contents at beginning of document.
- D. Provide additional copies of each warranty to include in operation and maintenance manuals.

BURBANK BRANCH RENOVATIONS, PORTLAND PUBLIC LIBRARY

PART 2 - PRODUCTS

2.1 MATERIALS

- A. Cleaning Agents: Use cleaning materials and agents recommended by manufacturer or fabricator of the surface to be cleaned. Do not use cleaning agents that are potentially hazardous to health or property or that might damage finished surfaces.

PART 3 - EXECUTION

3.1 FINAL CLEANING

- A. General: Perform final cleaning. Conduct cleaning and waste-removal operations to comply with local laws and ordinances and Federal and local environmental and antipollution regulations.
- B. Cleaning: Employ experienced workers or professional cleaners for final cleaning. Clean each surface or unit to condition expected in an average commercial building cleaning and maintenance program. Comply with manufacturer's written instructions.
 - 1. Complete the following cleaning operations before requesting inspection for certification of Substantial Completion for entire Project or for a designated portion of Project:
 - a. Clean Project site, yard, and grounds, in areas disturbed by construction activities, including landscape development areas, of rubbish, waste material, litter, and other foreign substances.
 - b. Sweep paved areas broom clean. Remove petrochemical spills, stains, and other foreign deposits.
 - c. Remove tools, construction equipment, machinery, and surplus material from Project site.
 - d. Remove snow and ice to provide safe access to building.
 - e. Clean exposed exterior and interior hard-surfaced finishes to a dirt-free condition, free of stains, films, and similar foreign substances. Avoid disturbing natural weathering of exterior surfaces. Restore reflective surfaces to their original condition.
 - f. Remove debris and surface dust from limited access spaces, including roofs, plenums, shafts, trenches, equipment vaults, manholes, attics, and similar spaces.
 - g. Sweep concrete floors broom clean in unoccupied spaces.
 - h. Vacuum carpet and similar soft surfaces, removing debris and excess nap; clean according to manufacturer's recommendations if visible soil or stains remain.
 - i. Clean transparent materials, including mirrors and glass in doors and windows. Remove glazing compounds and other noticeable, vision-obscuring materials. Polish mirrors and glass, taking care not to scratch surfaces.
 - j. Remove labels that are not permanent.
 - k. Wipe surfaces of mechanical and electrical equipment, elevator equipment, and similar equipment. Remove excess lubrication, paint and mortar droppings, and other foreign substances.

BURBANK BRANCH RENOVATIONS, PORTLAND PUBLIC LIBRARY

- l. Clean plumbing fixtures to a sanitary condition, free of stains, including stains resulting from water exposure.
 - m. Replace disposable air filters and clean permanent air filters. Clean exposed surfaces of diffusers, registers, and grills.
 - n. Clean ducts, blowers, and coils if units were operated without filters during construction or that display contamination with particulate matter on inspection.
 - 1) Clean HVAC system in compliance with NADCA Standard 1992-01. Provide written report on completion of cleaning.
 - o. Clean light fixtures, lamps, globes, and reflectors to function with full efficiency.
 - p. Leave Project clean and ready for occupancy.
- C. Construction Waste Disposal: Comply with waste disposal requirements in Section 015000 "Temporary Facilities and Controls."

3.2 REPAIR OF THE WORK

- A. Complete repair and restoration operations before requesting inspection for determination of Substantial Completion.
- B. Repair or remove and replace defective construction. Repairing includes replacing defective parts, refinishing damaged surfaces, touching up with matching materials, and properly adjusting operating equipment. Where damaged or worn items cannot be repaired or restored, provide replacements. Remove and replace operating components that cannot be repaired. Restore damaged construction and permanent facilities used during construction to specified condition.
 - 1. Remove and replace chipped, scratched, and broken glass, reflective surfaces, and other damaged transparent materials.
 - 2. Touch up and otherwise repair and restore marred or exposed finishes and surfaces. Replace finishes and surfaces that already show evidence of repair or restoration.
 - a. Do not paint over "UL" and other required labels and identification, including mechanical and electrical nameplates. Remove paint applied to required labels and identification.
 - 3. Replace parts subject to operating conditions during construction that may impede operation or reduce longevity.
 - 4. Replace burned-out bulbs, bulbs noticeably dimmed by hours of use, and defective and noisy starters in fluorescent and mercury vapor fixtures to comply with requirements for new fixtures.

END OF SECTION 017700

SECTION 017839 - PROJECT RECORD DOCUMENTS

PART 1 - GENERAL

1.1 RELATED DOCUMENTS

- A. Drawings and general provisions of the Contract, including General and Supplementary Conditions and other Division 01 Specification Sections, apply to this Section.

1.2 SUMMARY

- A. Section includes administrative and procedural requirements for project record documents, including the following:
 - 1. Record Drawings.
 - 2. Record Specifications.
 - 3. Record Product Data.
 - 4. Miscellaneous record submittals.
- B. Related Requirements:
 - 1. Section 017700 "Closeout Procedures" for general closeout procedures.

1.3 CLOSEOUT SUBMITTALS

- A. Record Drawings: Comply with the following:
 - 1. Number of Copies: Submit one set of marked-up record prints.
- B. Record Specifications: Submit one paper copy of Project's Specifications, including addenda and contract modifications.
- C. Record Product Data: Submit one paper copy or annotated PDF electronic files and directories of each submittal.
 - 1. Where record Product Data are required as part of operation and maintenance manuals, submit duplicate marked-up Product Data as a component of manual.
- D. Miscellaneous Record Submittals: See other Specification Sections for miscellaneous record-keeping requirements and submittals in connection with various construction activities. Submit one paper copy or annotated PDF electronic files and directories of each submittal.

PART 2 - PRODUCTS

2.1 RECORD DRAWINGS

- A. Record Prints: Maintain one set of marked-up paper copies of the Contract Drawings and Shop Drawings, incorporating new and revised drawings as modifications are issued.
1. Preparation: Mark record prints to show the actual installation where installation varies from that shown originally. Require individual or entity who obtained record data, whether individual or entity is Installer, subcontractor, or similar entity, to provide information for preparation of corresponding marked-up record prints.
 - a. Give particular attention to information on concealed elements that would be difficult to identify or measure and record later.
 - b. Accurately record information in an acceptable drawing technique.
 - c. Record data as soon as possible after obtaining it.
 - d. Record and check the markup before enclosing concealed installations.
 - e. Cross-reference record prints to corresponding archive photographic documentation.
 2. Content: Types of items requiring marking include, but are not limited to, the following:
 - a. Dimensional changes to Drawings.
 - b. Revisions to details shown on Drawings.
 - c. Depths of foundations below first floor.
 - d. Locations and depths of underground utilities.
 - e. Revisions to routing of piping and conduits.
 - f. Revisions to electrical circuitry.
 - g. Actual equipment locations.
 - h. Duct size and routing.
 - i. Locations of concealed internal utilities.
 - j. Changes made by Change Order or Construction Change Directive.
 - k. Changes made following Architect's written orders.
 - l. Details not on the original Contract Drawings.
 - m. Field records for variable and concealed conditions.
 - n. Record information on the Work that is shown only schematically.
 3. Mark the Contract Drawings and Shop Drawings completely and accurately. Use personnel proficient at recording graphic information in production of marked-up record prints.
 4. Mark record sets with erasable, red-colored pencil. Use other colors to distinguish between changes for different categories of the Work at same location.
 5. Mark important additional information that was either shown schematically or omitted from original Drawings.
 6. Note Construction Change Directive numbers, alternate numbers, Change Order numbers, and similar identification, where applicable.
- B. Format: Identify and date each record Drawing; include the designation "PROJECT RECORD DRAWING" in a prominent location.

BURBANK BRANCH RENOVATIONS, PORTLAND PUBLIC LIBRARY

1. Record Prints: Organize record prints and newly prepared record Drawings into manageable sets. Bind each set with durable paper cover sheets. Include identification on cover sheets.
2. Identification: As follows:
 - a. Project name.
 - b. Date.
 - c. Designation "PROJECT RECORD DRAWINGS."
 - d. Name of Architect.
 - e. Name of Contractor.

2.2 RECORD SPECIFICATIONS

- A. Preparation: Mark Specifications to indicate the actual product installation where installation varies from that indicated in Specifications, addenda, and contract modifications.
 1. Give particular attention to information on concealed products and installations that cannot be readily identified and recorded later.
 2. Mark copy with the proprietary name and model number of products, materials, and equipment furnished, including substitutions and product options selected.
 3. Record the name of manufacturer, supplier, Installer, and other information necessary to provide a record of selections made.
 4. For each principal product, indicate whether record Product Data has been submitted in operation and maintenance manuals instead of submitted as record Product Data.
 5. Note related Change Orders, record Product Data, and record Drawings where applicable.
- B. Format: Submit record Specifications as paper copy.

2.3 RECORD PRODUCT DATA

- A. Preparation: Mark Product Data to indicate the actual product installation where installation varies substantially from that indicated in Product Data submittal.
 1. Give particular attention to information on concealed products and installations that cannot be readily identified and recorded later.
 2. Include significant changes in the product delivered to Project site and changes in manufacturer's written instructions for installation.
 3. Note related Change Orders, record Specifications, and record Drawings where applicable.
- B. Format: Submit record Product Data as annotated PDF electronic file.
 1. Include record Product Data directory organized by Specification Section number and title, electronically linked to each item of record Product Data.

BURBANK BRANCH RENOVATIONS, PORTLAND PUBLIC LIBRARY

2.4 MISCELLANEOUS RECORD SUBMITTALS

- A. Assemble miscellaneous records required by other Specification Sections for miscellaneous record keeping and submittal in connection with actual performance of the Work. Bind or file miscellaneous records and identify each, ready for continued use and reference.
- B. Format: Submit miscellaneous record submittals as PDF electronic file.
 - 1. Include miscellaneous record submittals directory organized by Specification Section number and title, electronically linked to each item of miscellaneous record submittals.

PART 3 - EXECUTION

3.1 RECORDING AND MAINTENANCE

- A. Recording: Maintain one copy of each submittal during the construction period for project record document purposes. Post changes and revisions to project record documents as they occur; do not wait until end of Project.
- B. Maintenance of Record Documents and Samples: Store record documents and Samples in the field office apart from the Contract Documents used for construction. Do not use project record documents for construction purposes. Maintain record documents in good order and in a clean, dry, legible condition, protected from deterioration and loss. Provide access to project record documents for Architect's reference during normal working hours.

END OF SECTION 017839

SECTION 024119 - SELECTIVE DEMOLITION

PART 1 - GENERAL

1.1 RELATED DOCUMENTS

- A. Drawings and general provisions of the Contract, including General and Supplementary Conditions and Division 01 Specification Sections, apply to this Section.

1.2 SUMMARY

A. Section Includes:

1. Demolition and removal of selected portions of building or structure.
2. Demolition and removal of selected site elements.
3. Salvage of existing items to be reused or recycled.

B. Related Requirements:

1. Section 011000 "Summary" for restrictions on the use of the premises, Owner-occupancy requirements, and phasing requirements.
2. Section 017300 "Execution" for cutting and patching procedures.

1.3 DEFINITIONS

- A. Remove: Detach items from existing construction and legally dispose of them off-site unless indicated to be removed and salvaged or removed and reinstalled.
- B. Remove and Salvage: Carefully detach from existing construction, in a manner to prevent damage, and deliver to Owner ready for reuse.
- C. Remove and Reinstall: Detach items from existing construction, prepare for reuse, and reinstall where indicated.
- D. Existing to Remain: Existing items of construction that are not to be permanently removed and that are not otherwise indicated to be removed, removed and salvaged, or removed and reinstalled.

1.4 MATERIALS OWNERSHIP

- A. Unless otherwise indicated, demolition waste becomes property of Contractor.

1.5 PREINSTALLATION MEETINGS

- A. Predemolition Conference: Conduct conference at Project site.

BURBANK BRANCH RENOVATIONS, PORTLAND PUBLIC LIBRARY

1. Inspect and discuss condition of construction to be selectively demolished.
2. Review structural load limitations of existing structure.
3. Review and finalize selective demolition schedule and verify availability of materials, demolition personnel, equipment, and facilities needed to make progress and avoid delays.
4. Review requirements of work performed by other trades that rely on substrates exposed by selective demolition operations.
5. Review areas where existing construction is to remain and requires protection.

1.6 INFORMATIONAL SUBMITTALS

- A. Qualification Data: For refrigerant recovery technician.
- B. Proposed Protection Measures: Submit report, including drawings, that indicates the measures proposed for protecting individuals and property, for dust control. Indicate proposed locations and construction of barriers.
- C. Schedule of Selective Demolition Activities: Indicate the following:
 1. Detailed sequence of selective demolition and removal work, with starting and ending dates for each activity.
 2. Interruption of utility services. Indicate how long utility services will be interrupted.
 3. Coordination for shutoff, capping, and continuation of utility services.
 4. Use of stairs.
- D. Inventory: Submit a list of items to be removed and salvaged and deliver to Owner prior to start of demolition.
- E. Predemolition Photographs or Video: Submit before Work begins.
- F. Warranties: Documentation indicated that existing warranties are still in effect after completion of selective demolition.

1.7 CLOSEOUT SUBMITTALS

- A. Inventory: Submit a list of items that have been removed and salvaged.

1.8 FIELD CONDITIONS

- A. Owner will occupy portions of building immediately adjacent to selective demolition area. Conduct selective demolition so Owner's operations will not be disrupted.
- B. Conditions existing at time of inspection for bidding purpose will be maintained by Owner as far as practical.
 1. Before selective demolition, Owner will remove the following items:
- C. Notify Architect of discrepancies between existing conditions and Drawings before proceeding with selective demolition.

BURBANK BRANCH RENOVATIONS, PORTLAND PUBLIC LIBRARY

- D. Lead Containing Materials: All work operations impacting lead-based paints need to be performed in accordance with the following:
 - 1. OSHA 29 CFR Part 1926.62, Lead in Construction Standard.
 - 2. ME DEP Chapter 424, Lead Management Regulations.
 - 3. US EPA Renovation, Repair, & Repainting Rule (RRP), effective April 22, 2010.
- E. Hazardous Materials: It is not expected that hazardous materials will be encountered in the Work.
 - 1. If suspected hazardous materials are encountered, do not disturb; immediately notify Architect and Owner. Hazardous materials will be removed by Owner under a separate contract.
- F. Storage or sale of removed items or materials on-site is not permitted.
- G. Utility Service: Maintain existing utilities indicated to remain in service and protect them against damage during selective demolition operations.
 - 1. Maintain fire-protection facilities in service during selective demolition operations.

1.9 WARRANTY

- A. Existing Warranties: Remove, replace, patch, and repair materials and surfaces cut or damaged during selective demolition, by methods and with materials so as not to void existing warranties. Notify warrantor before proceeding.
- B. Notify warrantor on completion of selective demolition, and obtain documentation verifying that existing system has been inspected and warranty remains in effect. Submit documentation at Project closeout.

PART 2 - PRODUCTS

2.1 PERFORMANCE REQUIREMENTS

- A. Regulatory Requirements: Comply with governing EPA notification regulations before beginning selective demolition. Comply with hauling and disposal regulations of authorities having jurisdiction.
- B. Standards: Comply with ANSI/ASSE A10.6 and NFPA 241.

PART 3 - EXECUTION

3.1 EXAMINATION

- A. Verify that utilities have been disconnected and capped before starting selective demolition operations.

BURBANK BRANCH RENOVATIONS, PORTLAND PUBLIC LIBRARY

- B. Review record documents of existing construction provided by Owner. Owner does not guarantee that existing conditions are same as those indicated in record documents.
- C. Survey existing conditions and correlate with requirements indicated to determine extent of selective demolition required.
- D. When unanticipated mechanical, electrical, or structural elements that conflict with intended function or design are encountered, investigate and measure the nature and extent of conflict. Promptly submit a written report to Architect.
- E. Engage a professional engineer to perform an engineering survey of condition of building to determine whether removing any element might result in structural deficiency or unplanned collapse of any portion of structure or adjacent structures during selective building demolition operations.
 - 1. Perform surveys as the Work progresses to detect hazards resulting from selective demolition activities.
 - 2. Steel Tendons: Locate tensioned steel tendons and include recommendations for de-tensioning.
- F. Survey of Existing Conditions: Record existing conditions by use of measured drawings, preconstruction photographs, or preconstruction videotapes and templates.
 - 1. Comply with requirements specified in Section 013233 "Photographic Documentation."
 - 2. Inventory and record the condition of items to be removed and salvaged. Provide photographs or video of conditions that might be misconstrued as damage caused by salvage operations.
 - 3. Before selective demolition or removal of existing building elements that will be reproduced or duplicated in final Work, make permanent record of measurements, materials, and construction details required to make exact reproduction.

3.2 UTILITY SERVICES AND MECHANICAL/ELECTRICAL SYSTEMS

- A. Existing Services/Systems to Remain: Maintain services/systems indicated to remain and protect them against damage.
 - 1. Comply with requirements for existing services/systems interruptions specified in Section 011000 "Summary."
- B. Existing Services/Systems to Be Removed, Relocated, or Abandoned: Locate, identify, disconnect, and seal or cap off indicated utility services and mechanical/electrical systems serving areas to be selectively demolished.
 - 1. Owner will arrange to shut off indicated services/systems when requested by Contractor.
 - 2. Arrange to shut off indicated utilities with utility companies.
 - 3. If services/systems are required to be removed, relocated, or abandoned, provide temporary services/systems that bypass area of selective demolition and that maintain continuity of services/systems to other parts of building.
 - 4. Disconnect, demolish, and remove fire-suppression systems, plumbing, and HVAC systems, equipment, and components indicated to be removed.

BURBANK BRANCH RENOVATIONS, PORTLAND PUBLIC LIBRARY

- a. Piping to Be Removed: Remove portion of piping indicated to be removed and cap or plug remaining piping with same or compatible piping material.
- b. Piping to Be Abandoned in Place: Drain piping and cap or plug piping with same or compatible piping material.
- c. Equipment to Be Removed: Disconnect and cap services and remove equipment.
- d. Equipment to Be Removed and Reinstalled: Disconnect and cap services and remove, clean, and store equipment; when appropriate, reinstall, reconnect, and make equipment operational.
- e. Equipment to Be Removed and Salvaged: Disconnect and cap services and remove equipment and deliver to Owner.
- f. Ducts to Be Removed: Remove portion of ducts indicated to be removed and plug remaining ducts with same or compatible ductwork material.
- g. Ducts to Be Abandoned in Place: Cap or plug ducts with same or compatible ductwork material.

3.3 PREPARATION

- A. Temporary Facilities: Provide temporary barricades and other protection required to prevent injury to people and damage to adjacent buildings and facilities to remain.
 1. Provide protection to ensure safe passage of people around selective demolition area and to and from occupied portions of building.
 2. Provide temporary weather protection, during interval between selective demolition of existing construction on exterior surfaces and new construction, to prevent water leakage and damage to structure and interior areas.
 3. Protect walls, ceilings, floors, and other existing finish work that are to remain or that are exposed during selective demolition operations.
 4. Cover and protect furniture, furnishings, and equipment that have not been removed.
 5. Comply with requirements for temporary enclosures, dust control, heating, and cooling specified in Section 015000 "Temporary Facilities and Controls."
- B. Temporary Shoring: Provide and maintain shoring, bracing, and structural supports as required to preserve stability and prevent movement, settlement, or collapse of construction and finishes to remain, and to prevent unexpected or uncontrolled movement or collapse of construction being demolished.
 1. Strengthen or add new supports when required during progress of selective demolition.

3.4 SELECTIVE DEMOLITION, GENERAL

- A. General: Demolish and remove existing construction only to the extent required by new construction and as indicated. Use methods required to complete the Work within limitations of governing regulations and as follows:
 1. Proceed with selective demolition systematically, from higher to lower level. Complete selective demolition operations above each floor or tier before disturbing supporting members on the next lower level.
 2. Neatly cut openings and holes plumb, square, and true to dimensions required. Use cutting methods least likely to damage construction to remain or adjoining construction.

BURBANK BRANCH RENOVATIONS, PORTLAND PUBLIC LIBRARY

Use hand tools or small power tools designed for sawing or grinding, not hammering and chopping, to minimize disturbance of adjacent surfaces. Temporarily cover openings to remain.

3. Cut or drill from the exposed or finished side into concealed surfaces to avoid marring existing finished surfaces.
4. Do not use cutting torches until work area is cleared of flammable materials. At concealed spaces, such as duct and pipe interiors, verify condition and contents of hidden space before starting flame-cutting operations. Maintain fire watch and portable fire-suppression devices during flame-cutting operations.
5. Maintain adequate ventilation when using cutting torches.
6. Remove structural framing members and lower to ground by method suitable to avoid free fall and to prevent ground impact or dust generation.
7. Locate selective demolition equipment and remove debris and materials so as not to impose excessive loads on supporting walls, floors, or framing.
8. Dispose of demolished items and materials promptly. Comply with requirements in Section 017419 "Construction Waste Management and Disposal."

B. Removed and Salvaged Items:

1. Clean salvaged items.
2. Pack or crate items after cleaning. Identify contents of containers.
3. Store items in a secure area until delivery to Owner.
4. Transport items to Owner's storage area on-site.
5. Protect items from damage during transport and storage.

C. Removed and Reinstalled Items:

1. Clean and repair items to functional condition adequate for intended reuse.
2. Pack or crate items after cleaning and repairing. Identify contents of containers.
3. Protect items from damage during transport and storage.
4. Reinstall items in locations indicated. Comply with installation requirements for new materials and equipment. Provide connections, supports, and miscellaneous materials necessary to make item functional for use indicated.

D. Existing Items to Remain: Protect construction indicated to remain against damage and soiling during selective demolition. When permitted by Architect, items may be removed to a suitable, protected storage location during selective demolition and cleaned and reinstalled in their original locations after selective demolition operations are complete.

3.5 SELECTIVE DEMOLITION PROCEDURES FOR SPECIFIC MATERIALS

- A. Concrete: Demolish in small sections. Using power-driven saw, cut concrete to a depth of at least 3/4 inch at junctures with construction to remain. Dislodge concrete from reinforcement at perimeter of areas being demolished, cut reinforcement, and then remove remainder of concrete. Neatly trim openings to dimensions indicated.
- B. Concrete: Demolish in sections. Cut concrete full depth at junctures with construction to remain and at regular intervals using power-driven saw, then remove concrete between saw cuts.

BURBANK BRANCH RENOVATIONS, PORTLAND PUBLIC LIBRARY

- C. Masonry: Demolish in small sections. Cut masonry at junctures with construction to remain, using power-driven saw, then remove masonry between saw cuts.
- D. Concrete Slabs-on-Grade: Saw-cut perimeter of area to be demolished, then break up and remove.
- E. Resilient Floor Coverings: Remove floor coverings and adhesive according to recommendations in RFCI's "Recommended Work Practices for the Removal of Resilient Floor Coverings." Do not use methods requiring solvent-based adhesive strippers.

3.6 DISPOSAL OF DEMOLISHED MATERIALS

- A. General: Except for items or materials indicated to be recycled, reused, salvaged, reinstalled, or otherwise indicated to remain Owner's property, remove demolished materials from Project site and legally dispose of them in an EPA-approved landfill.
 - 1. Do not allow demolished materials to accumulate on-site.
 - 2. Remove and transport debris in a manner that will prevent spillage on adjacent surfaces and areas.
 - 3. Remove debris from elevated portions of building by chute, hoist, or other device that will convey debris to grade level in a controlled descent.
 - 4. Comply with requirements specified in Section 017419 "Construction Waste Management and Disposal."
- B. Burning: Do not burn demolished materials.
- C. Disposal: Transport demolished materials off Owner's property and legally dispose of them.

3.7 CLEANING

- A. Clean adjacent structures and improvements of dust, dirt, and debris caused by selective demolition operations. Return adjacent areas to condition existing before selective demolition operations began.

END OF SECTION 024119

SECTION 033000 - CAST-IN-PLACE CONCRETE

PART 1 - GENERAL

1.1 RELATED DOCUMENTS

- A. Drawings and general provisions of the Contract, including General and Supplementary Conditions and Division 01 Specification Sections, apply to this Section.

1.2 SUMMARY

- A. This Section specifies cast-in place concrete, including formwork, reinforcement, concrete materials, mixture design, placement procedures, and finishes, for the following:
 - 1. Slabs-on-grade.

1.3 DEFINITIONS

- A. Cementitious Materials: Portland cement alone or in combination with one or more of the following: blended hydraulic cement, fly ash and other pozzolans, ground granulated blast-furnace slag, and silica fume; subject to compliance with requirements.

1.4 SUBMITTALS

- A. Product Data: For each type of product indicated.
- B. Design Mixtures: For each concrete mixture. Submit alternate design mixtures when characteristics of materials, Project conditions, weather, test results, or other circumstances warrant adjustments.
 - 1. Indicate amounts of mixing water to be withheld for later addition at Project site.
- C. Material Certificates: For each of the following, signed by manufacturers:
 - 1. Cementitious materials.
 - 2. Admixtures.
 - 3. Steel reinforcement and accessories.
 - 4. Curing compounds.
- D. Floor surface flatness and levelness measurements to determine compliance with specified tolerances.

BURBANK BRANCH RENOVATIONS, PORTLAND PUBLIC LIBRARY

1.5 QUALITY ASSURANCE

- A. Manufacturer Qualifications: A firm experienced in manufacturing ready-mixed concrete products and that complies with ASTM C 94/C 94M requirements for production facilities and equipment.
 - 1. Manufacturer certified according to NRMCA's "Certification of Ready Mixed Concrete Production Facilities."
- B. Source Limitations: Obtain each type or class of cementitious material of the same brand from the same manufacturer's plant, obtain aggregate from one source, and obtain admixtures through one source from a single manufacturer.
- C. ACI Publications: Comply with the following unless modified by requirements in the Contract Documents:
 - 1. ACI 301, "Specification for Structural Concrete," Sections 1 through 5.
 - 2. ACI 117, "Specifications for Tolerances for Concrete Construction and Materials."

1.6 DELIVERY, STORAGE, AND HANDLING

- A. Steel Reinforcement: Deliver, store, and handle steel reinforcement to prevent bending and damage.

1.7 PROJECT CONDITIONS

- A. To prevent exterior concrete entrance slabs, pavement and walks from repeated freeze thaw cycles and de-icers before adequate curing to protect concrete has occurred, placement shall occur before October 1 or in the Spring after frost in the ground is gone and temperatures remain above freezing. No de-icers shall be used on the concrete during the project.
- B. Apply surface evaporation retardant to slab surface when water loss reaches .15 lbs of water loss per square foot (.6 kg per sm) per hour as determined in ACI 308.

PART 2 - PRODUCTS

2.1 MANUFACTURERS

- A. In other Part 2 articles where titles below introduce lists, the following requirements apply to product selection:
 - 1. Available Products: Subject to compliance with requirements, products that may be incorporated into the Work include, but are not limited to, products specified.
 - 2. Available Manufacturers: Subject to compliance with requirements, manufacturers offering products that may be incorporated into the Work include, but are not limited to, manufacturers specified.

2.2 FORM-FACING MATERIALS

- A. Smooth-Formed Finished Concrete: Form-facing panels that will provide continuous, true, and smooth concrete surfaces. Furnish in largest practicable sizes to minimize number of joints.
 - 1. Plywood, metal, or other approved panel materials.
 - 2. Exterior-grade plywood panels, suitable for concrete forms, complying with DOC PS 1, and as follows:
 - a. Structural 1, B-B or better; mill oiled and edge sealed.
 - b. B-B (Concrete Form), Class 1 or better; mill oiled and edge sealed.
- B. Rough-Formed Finished Concrete: Plywood, lumber, metal, or another approved material. Provide lumber dressed on at least two edges and one side for tight fit.
- C. Form-Release Agent: Commercially formulated form-release agent that will not bond with, stain, or adversely affect concrete surfaces and will not impair subsequent treatments of concrete surfaces.
 - 1. Formulate form-release agent with rust inhibitor for steel form-facing materials.

2.3 STEEL REINFORCEMENT

- A. Plain-Steel Wire: ASTM A 82, as drawn.
- B. Plain-Steel Welded Wire Reinforcement: ASTM A 185, plain, fabricated from as-drawn steel wire into flat sheets.

2.4 REINFORCEMENT ACCESSORIES

- A. Bar Supports: Bolsters, chairs, spacers, and other devices for spacing, supporting, and fastening reinforcing bars and welded wire reinforcement in place. Manufacture bar supports from steel wire, plastic, or precast concrete according to CRSI's "Manual of Standard Practice," of greater compressive strength than concrete and as follows:
 - 1. For concrete surfaces exposed to view where legs of wire bar supports contact forms, use CRSI Class 1 plastic-protected steel wire or CRSI Class 2 stainless-steel bar supports.

2.5 CONCRETE MATERIALS

- A. Cementitious Material: Use the following cementitious materials, of the same type, brand, and source, throughout Project:
 - 1. Portland Cement: ASTM C 150, Type I or II. Supplement with the following:
 - a. Fly Ash: ASTM C 618, Class F.
- B. Normal-Weight Aggregates: ASTM C 33, No. 57, graded.

BURBANK BRANCH RENOVATIONS, PORTLAND PUBLIC LIBRARY

1. Fine Aggregate: Sand shall consist of hard, tough and preferably siliceous material, clean, free from mineral or other coatings, soft particles, clay, loam or other deleterious matter.
2. Coarse Aggregate: Crushed stone or gravel, having clean, hard, durable, uncoated particles, free from deleterious matter. The 1-1/2" (38 mm) aggregate shall conform to gradation #467 and the 3/4" (19 mm) aggregate to size #67 in Table II of ASTM C-33. 3/4" (19 mm) aggregate shall be the minimum permissible size used, unless required for structural clearances between reinforcing bars or between bars and the forms require smaller aggregate size. Clearances requiring smaller aggregate size shall be submitted to the Engineer for verification and approval.

C. Water: ASTM C 94/C 94M and potable.

2.6 ADMIXTURES

A. Air-Entraining Admixture: ASTM C 260.

B. Chemical Admixtures: Provide admixtures certified by manufacturer to be compatible with other admixtures and that will not contribute water-soluble chloride ions exceeding those permitted in hardened concrete. Do not use calcium chloride or admixtures containing calcium chloride.

1. Water-Reducing Admixture: ASTM C 494/C 494M, Type A or Type F.
2. Retarding Admixture: ASTM C 494/C 494M, Type B.

2.7 VAPOR RETARDERS

A. Refer to Division 7 Section "Under-Slab Vapor Retarders."

2.8 FLOOR AND SLAB TREATMENTS

A. Exterior Sealer: Provide one of the following products:

1. ProSoCo, Inc.: Consolideck Saltguard WB.
2. Sika: Sikagard 70.

2.9 CURING MATERIALS

A. Evaporation Retarder: Waterborne, monomolecular film forming, manufactured for application to fresh concrete.

1. Available Products:
 - a. Dayton Superior Corporation; Sure Film (J-47).
 - b. Euclid Chemical Company (The); Eucobar.
 - c. L&M Construction Chemicals, Inc.; E-Con.
 - d. Meadows, W. R., Inc.; EVAPRE.
 - e. Sika Corporation, Inc.; SikaFilm.

BURBANK BRANCH RENOVATIONS, PORTLAND PUBLIC LIBRARY

- f. Vexcon Chemicals, Inc.; Certi-Vex Envio Set.
- B. Clear, Waterborne, Membrane-Forming Curing Compound: ASTM C 309, Type 1, Class B, nondissipating, certified by curing compound manufacturer to not interfere with bonding of floor covering.
 - 1. Available Products:
 - a. Anti-Hydro International, Inc.; AH Clear Cure WB.
 - b. Dayton Superior Corporation; Safe Cure and Seal (J-18).
 - c. Euclid Chemical Company (The); Aqua Cure VOX.
 - d. L&M Construction Chemicals, Inc.; Dress & Seal WB.
 - e. Tamms Industries, Inc.; Clearseal WB 150.

2.10 RELATED MATERIALS

- A. Expansion- and Isolation-Joint-Filler Strips: ASTM D 1751, asphalt-saturated cellulosic fiber or ASTM D 1752, cork or self-expanding cork.

2.11 CONCRETE MIXTURES, GENERAL

- A. Prepare design mixtures for each type and strength of concrete, proportioned on the basis of laboratory trial mixture or field test data, or both, according to ACI 301.
 - 1. Use a qualified independent testing agency for preparing and reporting proposed mixture designs based on laboratory trial mixtures.
- B. Cementitious Materials: Use fly ash, pozzolan, ground granulated blast-furnace slag, and silica fume as needed to reduce the total amount of portland cement, which would otherwise be used, by not less than 40 percent. Limit percentage, by weight, of cementitious materials other than portland cement in concrete as follows:
 - 1. Fly Ash: 25 percent.
 - 2. Combined Fly Ash and Pozzolan: 25 percent.
 - 3. Ground Granulated Blast-Furnace Slag: 50 percent.
 - 4. Combined Fly Ash or Pozzolan and Ground Granulated Blast-Furnace Slag: 50 percent portland cement minimum, with fly ash or pozzolan not exceeding 25 percent.
 - 5. Silica Fume: 10 percent.
 - 6. Combined Fly Ash, Pozzolans, and Silica Fume: 35 percent with fly ash or pozzolans not exceeding 25 percent and silica fume not exceeding 10 percent.
 - 7. Combined Fly Ash or Pozzolans, Ground Granulated Blast-Furnace Slag, and Silica Fume: 50 percent with fly ash or pozzolans not exceeding 25 percent and silica fume not exceeding 10 percent.
- C. Limit water-soluble, chloride-ion content in hardened concrete to 0.30 percent by weight of cement.
- D. Admixtures: Use admixtures according to manufacturer's written instructions.

BURBANK BRANCH RENOVATIONS, PORTLAND PUBLIC LIBRARY

1. Use water-reducing admixture in concrete, as required, for placement and workability.
2. Use water-reducing and retarding admixture when required by high temperatures, low humidity, or other adverse placement conditions.
3. Use corrosion-inhibiting admixture in concrete mixtures where indicated.

2.12 CONCRETE MIXTURES FOR BUILDING ELEMENTS

A. Slabs-on-Grade: Proportion normal-weight concrete mixture as follows:

1. Minimum Compressive Strength: 3000 psi at 28 days.
2. Minimum Cementitious Materials Content: 470 lb/cu. yd..
3. Slump Limit: 4 inches, plus or minus 1 inch.
4. Air Content: 6 percent, plus or minus 1.5 percent at point of delivery for 3/4-inch nominal maximum aggregate size.
5. Air Content: Do not allow air content of troweled finished floors to exceed 3 percent.

2.13 CONCRETE MIXING

A. Ready-Mixed Concrete: Measure, batch, mix, and deliver concrete according to ASTM C 94/C 94M, and furnish batch ticket information.

1. When air temperature is between 85 and 90 deg F, reduce mixing and delivery time from 1-1/2 hours to 75 minutes; when air temperature is above 90 deg F, reduce mixing and delivery time to 60 minutes.

PART 3 - EXECUTION

3.1 FORMWORK

- A. Design, erect, shore, brace, and maintain formwork, according to ACI 301, to support vertical, lateral, static, and dynamic loads, and construction loads that might be applied, until structure can support such loads.
- B. Construct formwork so concrete members and structures are of size, shape, alignment, elevation, and position indicated, within tolerance limits of ACI 117.
- C. Construct forms tight enough to prevent loss of concrete mortar.
- D. Fabricate forms for easy removal without hammering or prying against concrete surfaces. Provide crush or wrecking plates where stripping may damage cast concrete surfaces. Provide top forms for inclined surfaces steeper than 1.5 horizontal to 1 vertical.
- E. Set edge forms, bulkheads, and intermediate screed strips for slabs to achieve required elevations and slopes in finished concrete surfaces. Provide and secure units to support screed strips; use strike-off templates or compacting-type screeds.
- F. Clean forms and adjacent surfaces to receive concrete. Remove chips, wood, sawdust, dirt, and other debris just before placing concrete.

BURBANK BRANCH RENOVATIONS, PORTLAND PUBLIC LIBRARY

- G. Retighten forms and bracing before placing concrete, as required, to prevent mortar leaks and maintain proper alignment.
- H. Coat contact surfaces of forms with form-release agent, according to manufacturer's written instructions, before placing reinforcement.

3.2 REMOVING AND REUSING FORMS

- A. General: Formwork for sides of beams, walls, columns, and similar parts of the Work that does not support weight of concrete may be removed after cumulatively curing at not less than 50 deg F for 24 hours after placing concrete, if concrete is hard enough to not be damaged by form-removal operations and curing and protection operations are maintained.
- B. Clean and repair surfaces of forms to be reused in the Work. Split, frayed, delaminated, or otherwise damaged form-facing material will not be acceptable for exposed surfaces. Apply new form-release agent.
- C. When forms are reused, clean surfaces, remove fins and laitance, and tighten to close joints. Align and secure joints to avoid offsets. Do not use patched forms for exposed concrete surfaces unless approved by Architect.

3.3 STEEL REINFORCEMENT

- A. General: Comply with CRSI's "Manual of Standard Practice" for placing reinforcement.
 - 1. Do not cut or puncture vapor retarder. Repair damage and reseal vapor retarder before placing concrete.
- B. Clean reinforcement of loose rust and mill scale, earth, ice, and other foreign materials that would reduce bond to concrete.
- C. Accurately position, support, and secure reinforcement against displacement. Locate and support reinforcement with bar supports to maintain minimum concrete cover. Do not tack weld crossing reinforcing bars.
 - 1. Weld reinforcing bars according to AWS D1.4, where indicated.
- D. Set wire ties with ends directed into concrete, not toward exposed concrete surfaces.
- E. Install welded wire reinforcement in longest practicable lengths on bar supports spaced to minimize sagging. Lap edges and ends of adjoining sheets at least one mesh spacing. Offset laps of adjoining sheet widths to prevent continuous laps in either direction. Lace overlaps with wire.

3.4 CONCRETE PLACEMENT

- A. Before placing concrete, verify that installation of formwork, reinforcement, and embedded items is complete and that required inspections have been performed.

BURBANK BRANCH RENOVATIONS, PORTLAND PUBLIC LIBRARY

- B. Do not add water to concrete during delivery, at Project site, or during placement unless approved by Architect.
- C. Deposit and consolidate concrete for floors and slabs in a continuous operation, within limits of construction joints, until placement of a panel or section is complete.
 - 1. Consolidate concrete during placement operations so concrete is thoroughly worked around reinforcement and other embedded items and into corners.
 - 2. Maintain reinforcement in position on chairs during concrete placement.
 - 3. Screed slab surfaces with a straightedge and strike off to correct elevations.
 - 4. Slope surfaces uniformly to drains where required.
 - 5. Begin initial floating using bull floats or darbies to form a uniform and open-textured surface plane, before excess bleedwater appears on the surface. Do not further disturb slab surfaces before starting finishing operations.
- D. Cold-Weather Placement: Comply with ACI 306.1 and as follows. Protect concrete work from physical damage or reduced strength that could be caused by frost, freezing actions, or low temperatures.
 - 1. When average high and low temperature is expected to fall below 40 deg F for three successive days, maintain delivered concrete mixture temperature within the temperature range required by ACI 301.
 - 2. Do not use frozen materials or materials containing ice or snow. Do not place concrete on frozen subgrade or on subgrade containing frozen materials.
 - 3. Do not use calcium chloride, salt, or other materials containing antifreeze agents or chemical accelerators unless otherwise specified and approved in mixture designs.
- E. Hot-Weather Placement: Comply with ACI 301 and as follows:
 - 1. Maintain concrete temperature below 90 deg F at time of placement. Chilled mixing water or chopped ice may be used to control temperature, provided water equivalent of ice is calculated to total amount of mixing water. Using liquid nitrogen to cool concrete is Contractor's option.
 - 2. Fog-spray forms, steel reinforcement, and subgrade just before placing concrete. Keep subgrade uniformly moist without standing water, soft spots, or dry areas.

3.5 FINISHING FLOORS AND SLABS

- A. General: Comply with ACI 302.1R recommendations for screeding, restraighening, and finishing operations for concrete surfaces. Do not wet concrete surfaces.
- B. Float Finish: Consolidate surface with power-driven floats or by hand floating if area is small or inaccessible to power driven floats. Restraighten, cut down high spots, and fill low spots. Repeat float passes and restraighening until surface is left with a uniform, smooth, granular texture.
 - 1. Apply float finish to surfaces to receive trowel finish.
- C. Trowel Finish: After applying float finish, apply first troweling and consolidate concrete by hand or power-driven trowel. Continue troweling passes and restraighten until surface is free of

trowel marks and uniform in texture and appearance. Grind smooth any surface defects that would telegraph through applied coatings or floor coverings.

1. Apply a trowel finish to surfaces interior slabs.
2. Finish and measure surface so gap at any point between concrete surface and an unlevelled, freestanding, 10-foot- long straightedge resting on 2 high spots and placed anywhere on the surface does not exceed 1/4 inch

D. Broom Finish: Apply a broom finish to exterior concrete slabs.

1. Immediately after float finishing, slightly roughen trafficked surface by brooming with fiber-bristle broom perpendicular to main traffic route. Coordinate required final finish with Architect before application.

3.6 CONCRETE PROTECTING AND CURING

A. General: Protect freshly placed concrete from premature drying and excessive cold or hot temperatures. Comply with ACI 306.1 for cold-weather protection and ACI 301 for hot-weather protection during curing.

B. Evaporation Retarder: Apply evaporation retarder to unformed concrete surfaces if hot, dry, or windy conditions cause moisture loss approaching 0.2 lb/sq. ft. x h before and during finishing operations. Apply according to manufacturer's written instructions after placing, screeding, and bull floating or darbying concrete, but before float finishing.

C. Unformed Surfaces: Begin curing immediately after finishing concrete. Cure unformed surfaces, including floors and slabs, concrete floor toppings, and other surfaces.

D. Cure concrete according to ACI 308.1, by one or a combination of the following methods:

1. Curing Compound: Apply uniformly in continuous operation by power spray or roller according to manufacturer's written instructions. Recoat areas subjected to heavy rainfall within three hours after initial application. Maintain continuity of coating and repair damage during curing period.

END OF SECTION 033000

SECTION 042000 - UNIT MASONRY

PART 1 - GENERAL

1.1 RELATED DOCUMENTS

- A. Drawings and general provisions of the Contract, including General and Supplementary Conditions and Division 01 Specification Sections, apply to this Section.

1.2 SUMMARY

- A. Section Includes:
 - 1. Cut and patch of existing brick masonry.
 - 2. Mortar and grout.
 - 3. Miscellaneous masonry accessories.

1.3 ACTION SUBMITTALS

- A. Product Data: For each type of product indicated.

1.4 INFORMATIONAL SUBMITTALS

- A. Material Certificates: For each type and size of the following:
 - 1. Cementitious materials. Include brand, type, and name of manufacturer.
- B. Mix Designs: For each type of mortar and grout. Include description of type and proportions of ingredients.
 - 1. Include test reports for mortar mixes required to comply with property specification. Test according to ASTM C 109/C 109M for compressive strength, ASTM C 1506 for water retention, and ASTM C 91 for air content.
 - 2. Include test reports, according to ASTM C 1019, for grout mixes required to comply with compressive strength requirement.

1.5 QUALITY ASSURANCE

- A. Installer Qualifications: Company specializing in performing the work of this Section with minimum 5 years experience.
- B. Testing Agency Qualifications: Qualified according to ASTM C 1093 for testing indicated.

BURBANK BRANCH RENOVATIONS, PORTLAND PUBLIC LIBRARY

1.6 DELIVERY, STORAGE, AND HANDLING

- A. Store masonry units on elevated platforms in a dry location. If units are not stored in an enclosed location, cover tops and sides of stacks with waterproof sheeting, securely tied. If units become wet, do not install until they are dry.
- B. Store cementitious materials on elevated platforms, under cover, and in a dry location. Do not use cementitious materials that have become damp.
- C. Store aggregates where grading and other required characteristics can be maintained and contamination avoided.
- D. Deliver preblended, dry mortar mix in moisture-resistant containers designed for use with dispensing silos. Store preblended, dry mortar mix in delivery containers on elevated platforms, under cover, and in a dry location or in covered weatherproof dispensing silos.
- E. Store masonry accessories, including metal items, to prevent corrosion and accumulation of dirt and oil.

1.7 PROJECT CONDITIONS

- A. Protection of Masonry: During construction, cover tops of walls, projections, and sills with waterproof sheeting at end of each day's work. Cover partially completed masonry when construction is not in progress.
 - 1. Extend cover a minimum of 24 inches down both sides of walls and hold cover securely in place.
 - 2. Where one wythe of multiwythe masonry walls is completed in advance of other wythes, secure cover a minimum of 24 inches down face next to unconstructed wythe and hold cover in place.
- B. Do not apply uniform floor or roof loads for at least 12 hours and concentrated loads for at least three days after building masonry walls or columns.
- C. Stain Prevention: Prevent grout, mortar, and soil from staining the face of masonry to be left exposed or painted. Immediately remove grout, mortar, and soil that come in contact with such masonry.
 - 1. Protect base of walls from rain-splashed mud and from mortar splatter by spreading coverings on ground and over wall surface.
 - 2. Protect sills, ledges, and projections from mortar droppings.
 - 3. Protect surfaces of window and door frames, as well as similar products with painted and integral finishes, from mortar droppings.
 - 4. Turn scaffold boards near the wall on edge at the end of each day to prevent rain from splashing mortar and dirt onto completed masonry.
- D. Cold-Weather Requirements: Do not use frozen materials or materials mixed or coated with ice or frost. Do not build on frozen substrates or setting beds. Remove and replace unit masonry damaged by frost or by freezing conditions. Comply with the following requirements:

BURBANK BRANCH RENOVATIONS, PORTLAND PUBLIC LIBRARY

1. Cold-Weather Construction: When the anticipated daytime low temperature is within the limits indicated, use the following procedures:
 - a. 40 to 32 deg F: Heat mixing water or sand to produce mortar temperatures between 40 and 120 deg F.
 - b. 32 to 25 deg F: Heat mixing water and sand to produce mortar temperatures between 40 and 120 deg F. Heat grout materials to produce grout temperatures between 40 and 120 deg F. Heat masonry units to 40 deg F. Maintain mortar and grout above freezing until used in masonry. Use heat on both sides of walls under construction.
 - c. 25 to 20 deg F: Heat mixing water and sand to produce mortar temperatures between 40 and 120 deg F. Heat grout materials to produce grout temperatures between 40 and 120 deg F. Maintain mortar and grout above freezing until used in masonry. Heat masonry units to 40 deg F.
 - d. 20 deg F and Below: Heat mixing water and sand to produce mortar temperatures between 40 and 120 deg F. Heat grout materials to produce grout temperatures between 40 and 120 deg F. Maintain mortar and grout above freezing until used in masonry. Heat masonry units to 40 deg F.
 2. Cold-Weather Protection: When the anticipated daytime low temperature is within the limits indicated, coordinate with the General Contractor to provide the following protection. This is in addition to construction procedures specified above:
 - a. 40 to 32 deg F: Cover masonry with insulating blankets for 48 hours after construction.
 - b. 32 deg F and Below: Provide enclosure and heat to maintain temperatures above 32 deg F within the enclosure for 72 hours after construction.
 3. Cold-Weather Cleaning: Use liquid cleaning methods only when air temperature is 40 deg F and above and will remain so until masonry has dried out, but not less than 7 days after completion of cleaning.
- E. Hot-Weather Requirements: Coordinate with the General Contractor to protect unit masonry work when temperature and humidity conditions produce excessive evaporation of water from mortar and grout. Provide artificial shade and wind breaks and use cooled materials as required.
1. When ambient temperature exceeds 100 deg F, or 90 deg F with a wind velocity greater than 8 mph, do not spread mortar beds more than 48 inches ahead of masonry. Set masonry units within one minute of spreading mortar.

PART 2 - PRODUCTS

2.1 BRICK

- A. Face Brick: Salvage existing brick for cut and patching.

2.2 MORTAR AND GROUT MATERIALS

- A. General: Mortar and grout may be provided in one of two options; field mix of Portland cement, lime and sand or with specified Portland Cement-Lime Mix.
- B. Portland Cement: ASTM C 150, Type I or II.
- C. Hydrated Lime: ASTM C 207, Type S.
- D. Portland Cement-Lime Mix: Packaged blend of portland cement and hydrated lime containing no other ingredients.
 - 1. Available Products:
 - a. Blue Circle Cement, Inc.: Eaglebond High Strength Type "S".
 - b. Ciment Quebec, Inc.: Portland and Lime / Type S.
 - c. Dragon Cement and Concrete: Type S Masonry Cement.
- E. Aggregate for Mortar: ASTM C 144.
- F. Water: Potable.

2.3 MASONRY CLEANERS

- A. Proprietary Acidic Cleaner: Manufacturer's standard-strength cleaner designed for removing mortar/grout stains, efflorescence, and other new construction stains from new masonry without discoloring or damaging masonry surfaces. Use product expressly approved for intended use by cleaner manufacturer and manufacturer of masonry units being cleaned.
 - 1. Available Manufacturers:
 - a. 202V Vana-Stop; Diedrich Technologies, Inc.
 - b. Sure Klean Vana Trol; ProSoCo, Inc.

2.4 MORTAR AND GROUT MIXES

- A. General: Do not use admixtures, including pigments, air-entraining agents, accelerators, retarders, water-repellent agents, antifreeze compounds, or other admixtures, unless otherwise indicated.
 - 1. Do not use calcium chloride in mortar or grout.
 - 2. Use portland cement-lime mortar unless otherwise indicated.
- B. Preblended, Dry Mortar Mix: Furnish dry mortar ingredients in form of a preblended mix. Measure quantities by weight to ensure accurate proportions, and thoroughly blend ingredients before delivering to Project site.
- C. Mortar for Unit Masonry: Comply with ASTM C 270, Property Specification. Provide the following types of mortar for applications stated unless another type is indicated.

BURBANK BRANCH RENOVATIONS, PORTLAND PUBLIC LIBRARY

1. For brick masonry, use Type S.

PART 3 - EXECUTION

3.1 INSTALLATION, GENERAL

- A. Thickness: Build cavity and composite walls and other masonry construction to full thickness shown. Build single-wythe walls to actual widths of masonry units, using units of widths indicated.
- B. Use full-size units without cutting if possible. If cutting is required to provide a continuous pattern or to fit adjoining construction, cut units with motor-driven saws; provide clean, sharp, unchipped edges. Allow units to dry before laying unless wetting of units is specified. Install cut units with cut surfaces and, where possible, cut edges concealed.
- C. Select and arrange units for exposed unit masonry to produce a uniform blend of colors and textures.

3.2 LAYING MASONRY WALLS

- A. Lay out walls in advance for accurate spacing of surface bond patterns with uniform joint thicknesses and for accurate location of openings, movement-type joints, returns, and offsets. Avoid using less-than-half-size units, particularly at corners, jambs, and, where possible, at other locations.
- B. Bond Pattern for Exposed Masonry: Unless otherwise indicated, lay exposed masonry in running bond; do not use units with less than nominal 4-inch horizontal face dimensions at corners or jambs.
- C. Lay concealed masonry with all units in a wythe in running bond or bonded by lapping not less than 4-inches. Bond and interlock each course of each wythe at corners. Do not use units with less than nominal 4-inch horizontal face dimensions at corners or jambs.
- D. Stopping and Resuming Work: Stop work by racking back units in each course from those in course below; do not tooth. When resuming work, clean masonry surfaces that are to receive mortar, remove loose masonry units and mortar, and wet brick if required before laying fresh masonry.
- E. Where cutting and patching of existing masonry walls, tooth in new work where finished product will be exposed to view.
- F. Built-in Work: As construction progresses, build in items specified in this and other Sections. Fill in solidly with masonry around built-in items.
- G. Fill space between steel frames and masonry solidly with mortar unless otherwise indicated.
- H. Where built-in items are to be embedded in cores of hollow masonry units, place a layer of metal lath, wire mesh, or plastic mesh in the joint below and rod mortar or grout into core.

3.3 MORTAR BEDDING AND JOINTING

- A. Lay solid masonry units or brick with completely filled bed and head joints; butter ends with sufficient mortar to fill head joints and shove into place. Do not deeply furrow bed joints or slush head joints.
- B. Tool exposed joints slightly concave when thumbprint hard, using a jointer larger than joint thickness unless otherwise indicated.
 - 1. For glazed masonry units, use a nonmetallic jointer 3/4 inch or more in width.
- C. Cut joints flush for masonry walls to receive plaster or other direct-applied finishes (other than paint) unless otherwise indicated.
- D. Do not shift or tap masonry units after mortar has achieved initial set. Where adjustment is necessary, remove mortar and replace.

3.4 REPAIRING, POINTING, AND CLEANING

- A. Remove and replace masonry units that are loose, chipped, broken, stained, or otherwise damaged or that do not match adjoining units. Install new units to match adjoining units; install in fresh mortar, pointed to eliminate evidence of replacement.
- B. Pointing: During the tooling of joints, enlarge voids and holes, except weep holes, and completely fill with mortar. Point up joints, including corners, openings, and adjacent construction, to provide a neat, uniform appearance. Prepare joints for sealant application, where indicated.
- C. In-Progress Cleaning: Clean unit masonry as work progresses by dry brushing to remove mortar fins and smears before tooling joints.
- D. Final Cleaning for Brick: After mortar is thoroughly set and cured for a minimum of 7 days, clean exposed masonry as follows:
 - 1. Remove large mortar particles by hand with wooden paddles and nonmetallic scrape hoes or chisels.
 - 2. Protect adjacent stone and nonmasonry surfaces from contact with cleaner by covering them with liquid strippable masking agent or polyethylene film and waterproof masking tape.
 - 3. Protect metal roof and/or floor deck from contact with cleaner by covering with polyethylene film. Should damage occur to metal deck, repair damaged deck finish by re-priming steel deck materials or applying a ZRC coating to galvanized deck materials.
 - 4. Wet wall surfaces with water before applying cleaners; remove cleaners promptly by rinsing surfaces thoroughly with clear water. Do not use pressure sprayers, garden hose type and pressure only.
 - 5. Clean brick by bucket-and-brush hand-cleaning method described in BIA Technical Notes 20 Revised, and manufacturer's printed instructions.

BURBANK BRANCH RENOVATIONS, PORTLAND PUBLIC LIBRARY

3.5 MASONRY WASTE DISPOSAL

- A. Excess Masonry Waste: Remove excess clean masonry waste and legally dispose of off Owner's property.

END OF SECTION 042000

SECTION 055000 - METAL FABRICATIONS

PART 1 - GENERAL

1.1 RELATED DOCUMENTS

- A. Drawings and general provisions of the Contract, including General and Supplementary Conditions and Division 01 Specification Sections, apply to this Section.

1.2 SUMMARY

- A. Section Includes:
 - 1. Steel framing and supports for applications where framing and supports are not specified in other Sections.
 - 2. Elevator pit sump covers.
 - 3. Loose bearing and leveling plates for applications where they are not specified in other Sections.
- B. Products furnished, but not installed, under this Section include the following:
 - 1. Loose steel lintels.
 - 2. Anchor bolts, steel pipe sleeves, slotted-channel inserts, and wedge-type inserts indicated to be cast into concrete or built into unit masonry.

1.3 COORDINATION

- A. Coordinate selection of shop primers with topcoats to be applied over them. Comply with paint and coating manufacturers' written recommendations to ensure that shop primers and topcoats are compatible with one another.
- B. Coordinate installation of metal fabrications that are anchored to or that receive other work. Furnish setting drawings, templates, and directions for installing anchorages, including sleeves, concrete inserts, anchor bolts, and items with integral anchors, that are to be embedded in concrete or masonry. Deliver such items to Project site in time for installation.

1.4 ACTION SUBMITTALS

- A. Product Data: For the following:
- B. Shop Drawings: Show fabrication and installation details. Include plans, elevations, sections, and details of metal fabrications and their connections. Show anchorage and accessory items. Provide Shop Drawings for the following:
 - 1. Steel framing and supports for applications where framing and supports are not specified in other Sections.
 - 2. Elevator pit sump covers.

BURBANK BRANCH RENOVATIONS, PORTLAND PUBLIC LIBRARY

3. Loose bearing and leveling plates for applications where they are not specified in other Sections.

C. Samples for Verification: For each type and finish of extruded nosing and tread.

D. Delegated-Design Submittal: For alternating tread devices, including analysis data signed and sealed by the qualified professional engineer responsible for their preparation.

1.5 INFORMATIONAL SUBMITTALS

A. Qualification Data: For professional engineer.

B. Welding certificates.

C. Paint Compatibility Certificates: From manufacturers of topcoats applied over shop primers, certifying that shop primers are compatible with topcoats.

1.6 QUALITY ASSURANCE

A. Welding Qualifications: Qualify procedures and personnel according to AWS D1.1/D1.1M, "Structural Welding Code - Steel."

1.7 FIELD CONDITIONS

A. Field Measurements: Verify actual locations of walls and other construction contiguous with metal fabrications by field measurements before fabrication.

PART 2 - PRODUCTS

2.1 METALS

A. Metal Surfaces, General: Provide materials with smooth, flat surfaces unless otherwise indicated. For metal fabrications exposed to view in the completed Work, provide materials without seam marks, roller marks, rolled trade names, or blemishes.

B. Steel Plates, Shapes, and Bars: ASTM A 36/A 36M.

C. Steel Tubing: ASTM A 500/A 500M, cold-formed steel tubing.

D. Steel Pipe: ASTM A 53/A 53M, Standard Weight (Schedule 40) unless otherwise indicated.

2.2 FASTENERS

A. General: Unless otherwise indicated, provide Type 304 stainless-steel fasteners for exterior use and zinc-plated fasteners with coating complying with ASTM B 633 or ASTM F 1941, Class Fe/Zn 5, at exterior walls. Select fasteners for type, grade, and class required.

BURBANK BRANCH RENOVATIONS, PORTLAND PUBLIC LIBRARY

- B. Steel Bolts and Nuts: Regular hexagon-head bolts, ASTM A 307, Grade A; with hex nuts, ASTM A 563; and, where indicated, flat washers.
- C. Steel Bolts and Nuts: Regular hexagon-head bolts, ASTM A 325, Type 3; with hex nuts, ASTM A 563, Grade C3; and, where indicated, flat washers.
- D. Stainless-Steel Bolts and Nuts: Regular hexagon-head annealed stainless-steel bolts, ASTM F 593; with hex nuts, ASTM F 594; and, where indicated, flat washers; Alloy Group 1.
- E. Anchor Bolts: ASTM F 1554, Grade 36, of dimensions indicated; with nuts, ASTM A 563; and, where indicated, flat washers.
 - 1. Hot-dip galvanize or provide mechanically deposited, zinc coating where item being fastened is indicated to be galvanized.
- F. Anchors, General: Anchors capable of sustaining, without failure, a load equal to six times the load imposed when installed in unit masonry and four times the load imposed when installed in concrete, as determined by testing according to ASTM E 488/E 488M, conducted by a qualified independent testing agency.
- G. Cast-in-Place Anchors in Concrete: Either threaded type or wedge type unless otherwise indicated; galvanized ferrous castings, either ASTM A 47/A 47M malleable iron or ASTM A 27/A 27M cast steel. Provide bolts, washers, and shims as needed, all hot-dip galvanized per ASTM F 2329.
- H. Post-Installed Anchors: Torque-controlled expansion anchors or chemical anchors.
 - 1. Material for Interior Locations: Carbon-steel components zinc plated to comply with ASTM B 633 or ASTM F 1941, Class Fe/Zn 5, unless otherwise indicated.
 - 2. Material for Exterior Locations and Where Stainless Steel Is Indicated: Alloy Group 1 stainless-steel bolts, ASTM F 593, and nuts, ASTM F 594.

2.3 MISCELLANEOUS MATERIALS

- A. Universal Shop Primer: Fast-curing, lead- and chromate-free, universal modified-alkyd primer complying with MPI#79 and compatible with topcoat.
 - 1. Use primer containing pigments that make it easily distinguishable from zinc-rich primer.
- B. Epoxy Zinc-Rich Primer: Complying with MPI#20 and compatible with topcoat.
 - 1. Products: Subject to compliance with requirements, provide one of the following:
 - a. Benjamin Moore & Co.; Epoxy Zinc-Rich Primer CM18/19.
 - b. ICI Devco Coatings; Catha-Coat 313.
 - c. International Coatings Limited; Interzinc 315 Epoxy Zinc-Rich Primer.
 - d. PPG Architectural Finishes, Inc.; Epoxy Zinc Rich Primer 97-670.
 - e. Sherwin-Williams Company (The); Zinc Clad IV, B69A8/B69V8.
 - f. Tnemec Company, Inc.; Tneme-Zinc 90-97.
- C. Bituminous Paint: Cold-applied asphalt emulsion complying with ASTM D 1187/D 1187M.

BURBANK BRANCH RENOVATIONS, PORTLAND PUBLIC LIBRARY

1. Available Products:

- a. Sealmastic, Type 1; W. R. Meadows
- b. Hydrocide 600; Sonneborn Building Products.
- c. Karnak 100 AF; Karnac Chemical Corp.

D. Nonshrink, Nonmetallic Grout: Factory-packaged, nonstaining, noncorrosive, nongaseous grout complying with ASTM C 1107/C 1107M. Provide grout specifically recommended by manufacturer for interior and exterior applications.

1. Available Products:

- a. Five Star Grout by Five Star Products, Inc.
- b. Masterflow 928 Grout by Master Builders Technologies.
- c. SonogROUT 10K by Sonneborn.
- d. 14K Hy Flow by Sonneborn.

2.4 FABRICATION, GENERAL

- A. Shop Assembly: Preassemble items in the shop to greatest extent possible. Disassemble units only as necessary for shipping and handling limitations. Use connections that maintain structural value of joined pieces. Clearly mark units for reassembly and coordinated installation.
- B. Cut, drill, and punch metals cleanly and accurately. Remove burrs and ease edges to a radius of approximately 1/32 inch unless otherwise indicated. Remove sharp or rough areas on exposed surfaces.
- C. Form bent-metal corners to smallest radius possible without causing grain separation or otherwise impairing work.
- D. Form exposed work with accurate angles and surfaces and straight edges.
- E. Weld corners and seams continuously to comply with the following:
 1. Use materials and methods that minimize distortion and develop strength and corrosion resistance of base metals.
 2. Obtain fusion without undercut or overlap.
 3. Remove welding flux immediately.
 4. At exposed connections, finish exposed welds and surfaces smooth and blended so no roughness shows after finishing and contour of welded surface matches that of adjacent surface.
- F. Form exposed connections with hairline joints, flush and smooth, using concealed fasteners or welds where possible. Where exposed fasteners are required, use Phillips flat-head (countersunk) fasteners unless otherwise indicated. Locate joints where least conspicuous.
- G. Fabricate seams and other connections that are exposed to weather in a manner to exclude water. Provide weep holes where water may accumulate.

BURBANK BRANCH RENOVATIONS, PORTLAND PUBLIC LIBRARY

- H. Cut, reinforce, drill, and tap metal fabrications as indicated to receive finish hardware, screws, and similar items.
- I. Provide for anchorage of type indicated; coordinate with supporting structure. Space anchoring devices to secure metal fabrications rigidly in place and to support indicated loads.

2.5 MISCELLANEOUS FRAMING AND SUPPORTS

- A. General: Provide steel framing and supports not specified in other Sections as needed to complete the Work.
- B. Fabricate units from steel shapes, plates, and bars of welded construction unless otherwise indicated. Fabricate to sizes, shapes, and profiles indicated and as necessary to receive adjacent construction.
 - 1. Furnish inserts for units installed after concrete is placed.
- C. Prime miscellaneous framing and supports.

2.6 ELEVATOR PIT SUMP COVERS

- A. Fabricate from 3/16-inch rolled-steel floor plate with four 1-inch- diameter holes for water drainage and for lifting.
- B. Fabricate from welded or pressure-locked steel bar grating Limit openings in gratings to no more than 1/2 inch in least dimension.
- C. Support Frame: Provide 1-1/2 by 1-1/2 by 1/4 inch steel angle around perimeter of sump pit, fastened with 1/4 inch galvanized expansion anchors.
- D. Prime steel elevator pit cover, including support frame and fasteners, with zinc-rich primer.

2.7 LOOSE BEARING AND LEVELING PLATES

- A. Provide loose bearing and leveling plates for steel items bearing on masonry or concrete construction. Drill plates to receive anchor bolts and for grouting.
- B. Prime plates with zinc-rich primer.

2.8 HALF-WALL SUPPORT POST

- A. Prefabricated steel post designed to fit into 3-5/8 inch metal stud wall to support short walls.
 - 1. Available Products: SKB Knee Brace Kit by Pittcon Softforms, LLC.

BURBANK BRANCH RENOVATIONS, PORTLAND PUBLIC LIBRARY

2.9 FINISHES, GENERAL

- A. Finish metal fabrications after assembly.
- B. Finish exposed surfaces to remove tool and die marks and stretch lines, and to blend into surrounding surface.

2.10 STEEL AND IRON FINISHES

- A. Shop prime iron and steel items not indicated to be galvanized unless they are to be embedded in concrete, sprayed-on fireproofing, or masonry, or unless otherwise indicated.
 - 1. Shop prime with universal shop primer unless zinc-rich primer is indicated.
- B. Preparation for Shop Priming: Prepare surfaces to comply with SSPC-SP 6/NACE No. 3, "Commercial Blast Cleaning."
- C. Shop Priming: Apply shop primer to comply with SSPC-PA 1, "Paint Application Specification No. 1: Shop, Field, and Maintenance Painting of Steel," for shop painting.

PART 3 - EXECUTION

3.1 INSTALLATION, GENERAL

- A. Cutting, Fitting, and Placement: Perform cutting, drilling, and fitting required for installing metal fabrications. Set metal fabrications accurately in location, alignment, and elevation; with edges and surfaces level, plumb, true, and free of rack; and measured from established lines and levels.
- B. Fit exposed connections accurately together to form hairline joints. Weld connections that are not to be left as exposed joints but cannot be shop welded because of shipping size limitations. Do not weld, cut, or abrade surfaces of exterior units that have been hot-dip galvanized after fabrication and are for bolted or screwed field connections.
- C. Field Welding: Comply with the following requirements:
 - 1. Use materials and methods that minimize distortion and develop strength and corrosion resistance of base metals.
 - 2. Obtain fusion without undercut or overlap.
 - 3. Remove welding flux immediately.
 - 4. At exposed connections, finish exposed welds and surfaces smooth and blended so no roughness shows after finishing and contour of welded surface matches that of adjacent surface.
- D. Fastening to In-Place Construction: Provide anchorage devices and fasteners where metal fabrications are required to be fastened to in-place construction. Provide threaded fasteners for use with concrete and masonry inserts, toggle bolts, through bolts, lag screws, wood screws, and other connectors.

BURBANK BRANCH RENOVATIONS, PORTLAND PUBLIC LIBRARY

- E. Provide temporary bracing or anchors in formwork for items that are to be built into concrete, masonry, or similar construction.

3.2 INSTALLING MISCELLANEOUS FRAMING AND SUPPORTS

- A. General: Install framing and supports to comply with requirements of items being supported, including manufacturers' written instructions and requirements indicated on Shop Drawings.
- B. Anchor supports for low walls securely to, and rigidly brace from, building structure.

3.3 ELEVATOR SUMP PIT COVER

- A. Set perimeter support angles 1/4 inch below the edge of the sump pit to allow the sump cover plate to set flush with elevator pit floor.

3.4 ADJUSTING AND CLEANING

- A. Touchup Painting: Immediately after erection, clean field welds, bolted connections, and abraded areas. Paint uncoated and abraded areas with the same material as used for shop painting to comply with SSPC-PA 1 for touching up shop-painted surfaces.
 - 1. Apply by brush or spray to provide a minimum 2.0-mil dry film thickness.
- B. Galvanized Surfaces: Clean field welds, bolted connections, and abraded areas and repair galvanizing to comply with ASTM A 780/A 780M.

END OF SECTION 055000

SECTION 061000 - ROUGH CARPENTRY

PART 1 - GENERAL

1.1 RELATED DOCUMENTS

- A. Drawings and general provisions of the Contract, including General and Supplementary Conditions and Division 01 Specification Sections, apply to this Section.

1.2 SUMMARY

- A. Section Includes:
 - 1. Framing with dimension lumber.
 - 2. Framing with engineered wood products.
 - 3. Wood blocking and nailers.
 - 4. Wood furring.
 - 5. Wall sheathing.
 - 6. Roof sheathing.
 - 7. Subflooring.
 - 8. Underlayment.

1.3 DEFINITIONS

- A. Dimension Lumber: Lumber of 2 inches nominal or greater but less than 5 inches nominal in least dimension.
- B. Lumber grading agencies, and the abbreviations used to reference them, include the following:
 - 1. NeLMA: Northeastern Lumber Manufacturers' Association.
 - 2. NLGA: National Lumber Grades Authority.
 - 3. RIS: Redwood Inspection Service.
 - 4. SPIB: The Southern Pine Inspection Bureau.
 - 5. WCLIB: West Coast Lumber Inspection Bureau.
 - 6. WWPA: Western Wood Products Association.

1.4 ACTION SUBMITTALS

- A. Product Data: For each type of process and factory-fabricated product. Indicate component materials and dimensions and include construction and application details.
 - 1. Include data for wood-preservative treatment from chemical treatment manufacturer and certification by treating plant that treated materials comply with requirements. Indicate type of preservative used and net amount of preservative retained.
 - 2. For products receiving a waterborne treatment, include statement that moisture content of treated materials was reduced to levels specified before shipment to Project site.

BURBANK BRANCH RENOVATIONS, PORTLAND PUBLIC LIBRARY

3. Include copies of warranties from chemical treatment manufacturers for each type of treatment.

1.5 INFORMATIONAL SUBMITTALS

- A. Material Certificates: For dimension lumber specified to comply with minimum allowable unit stresses. Indicate species and grade selected for each use and design values approved by the ALSC Board of Review.
- B. Evaluation Reports: For the following, from ICC-ES:
 1. Wood-preservative-treated wood.
 2. Metal framing anchors.

1.6 QUALITY ASSURANCE

- A. Testing Agency Qualifications: For testing agency providing classification marking for fire-retardant treated material, an inspection agency acceptable to authorities having jurisdiction that periodically performs inspections to verify that the material bearing the classification marking is representative of the material tested.

1.7 DELIVERY, STORAGE, AND HANDLING

- A. Stack lumber flat with spacers beneath and between each bundle to provide air circulation. Protect lumber from weather by covering with waterproof sheeting, securely anchored. Provide for air circulation around stacks and under coverings.
- B. Stack plywood and other panels flat with spacers between each bundle to provide air circulation. Provide for air circulation around stacks and under coverings.

PART 2 - PRODUCTS

2.1 WOOD PRODUCTS, GENERAL

- A. Lumber: DOC PS 20 and applicable rules of grading agencies indicated. If no grading agency is indicated, provide lumber that complies with the applicable rules of any rules-writing agency certified by the ALSC Board of Review. Provide lumber graded by an agency certified by the ALSC Board of Review to inspect and grade lumber under the rules indicated.
 1. Factory mark each piece of lumber with grade stamp of grading agency.
 2. Where nominal sizes are indicated, provide actual sizes required by DOC PS 20 for moisture content specified. Where actual sizes are indicated, they are minimum dressed sizes for dry lumber.
 3. Provide dressed lumber, S4S, unless otherwise indicated.
- B. Maximum Moisture Content of Lumber: 15 percent for 2-inch nominal thickness or less, 19 percent for more than 2-inch nominal thickness unless otherwise indicated.

- C. Engineered Wood Products: Provide engineered wood products acceptable to authorities having jurisdiction and for which current model code research or evaluation reports exist that show compliance with building code in effect for Project.
 - 1. Allowable Design Stresses: Provide engineered wood products with allowable design stresses, as published by manufacturer that meet or exceed those indicated. Manufacturer's published values shall be determined from empirical data or by rational engineering analysis and demonstrated by comprehensive testing performed by a qualified independent testing agency.
- D. Plywood: DOC PS 1.

2.2 WOOD-PRESERVATIVE-TREATED LUMBER

- A. Preservative Treatment by Pressure Process: AWPA U1; Use Category UC2 for interior construction not in contact with the ground, Use Category UC3b for exterior construction not in contact with the ground, and Use Category UC4a for items in contact with the ground.
 - 1. Preservative Chemicals: Acceptable to authorities having jurisdiction and containing no arsenic or chromium.
 - 2. For exposed items indicated to receive a stained or natural finish, use chemical formulations that do not require incising, contain colorants, bleed through, or otherwise adversely affect finishes.
- B. Kiln-dry lumber after treatment to a maximum moisture content of 19 percent. Do not use material that is warped or that does not comply with requirements for untreated material.
- C. Mark lumber with treatment quality mark of an inspection agency approved by the ALSC Board of Review.
 - 1. For exposed lumber indicated to receive a stained or natural finish, mark end or back of each piece or omit marking and provide certificates of treatment compliance issued by inspection agency.
- D. Application: Treat items indicated on Drawings, and the following:
 - 1. Wood cants, nailers, curbs, equipment support bases, blocking, stripping, and similar members in connection with roofing, flashing, vapor barriers, and waterproofing.
 - 2. Wood sills, sleepers, blocking, furring, stripping, and similar concealed members in contact with masonry or concrete.
 - 3. Wood framing and furring attached directly to the interior of below-grade exterior masonry or concrete walls.
 - 4. Wood framing members that are less than 18 inches above the ground in crawlspaces or unexcavated areas.
 - 5. Wood floor plates that are installed over concrete slabs-on-grade.

2.3 PRESERVATIVE-TREATED PLYWOOD

- A. Preservative Treatment by Pressure Process: AWPA C9.

2.4 DIMENSION LUMBER FRAMING

- A. Load-Bearing, Joists, Rafters, Nailers for Steel Beams, Structural Blocking, and Other Framing: No. 2 grade or better.
 - 1. Species:
 - a. Douglas Fir, Douglas Fir-Larch.
 - b. Spruce-pine-fir; NLGA.
 - 2. Spruce-pine-fir (South) is not acceptable, except where pressure-treated materials are indicated.

2.5 ENGINEERED WOOD PRODUCTS

- A. Laminated-Veneer Lumber: Structural composite lumber made from wood veneers with grain primarily parallel to member lengths, evaluated and monitored according to ASTM D 5456 and manufactured with an exterior-type adhesive complying with ASTM D 2559.
 - 1. Manufacturers: Subject to compliance with requirements, provide products by one of the following:
 - a. Boise Cascade Corporation.
 - b. Georgia-Pacific.
 - c. Louisiana-Pacific Corporation.
 - d. Weyerhaeuser Company.

2.6 WALL SHEATHING

- A. Plywood Wall Sheathing: Exposure 1, Structural I (CDX) sheathing.
 - 1. Span Rating: Not less than 24/0 or 32/16.
 - 2. Nominal Thickness: Not less than 1/2 inch.

2.7 SUBFLOORING AND UNDERLAYMENT

- A. Plywood Subflooring: Exposure 1, Structural I (CDX) single-floor panels or sheathing.
 - 1. Span Rating: Not less than 24 o.c. or 32/16.
 - 2. Nominal Thickness: Not less than 3/4 inch.
 - 3. Edges: Tongue and groove.
- B. Underlayment, General: Provide underlayment in nominal thicknesses indicated or, if not indicated, not less than 1/4 inch over smooth subfloors and not less than 3/8 inch over board or uneven subfloors.
- C. Plywood Underlayment for Resilient Flooring: DOC PS 1, 3-ply Canadian poplar plywood with fully sanded face.

BURBANK BRANCH RENOVATIONS, PORTLAND PUBLIC LIBRARY

1. Nominal Thickness: 3/8 inch.
 2. Product: Multiply Underlayment by Multiply Plywood.
- D. Plywood Underlayment for Carpet: DOC PS 1, Exterior, A-C Plugged.

2.8 MISCELLANEOUS LUMBER

- A. General: Provide miscellaneous lumber indicated and lumber for support or attachment of other construction, including the following:
1. Non-structural blocking.
 2. Furring.
- B. For items of dimension lumber size, provide No. 2 grade lumber and any of the following species:
1. Spruce-pine-fir; NLGA.
- C. For blocking not used for attachment of other construction, Utility, Stud, or No. 3 grade lumber of any species may be used provided that it is cut and selected to eliminate defects that will interfere with its attachment and purpose.
- D. For blocking and nailers used for attachment of other construction, select and cut lumber to eliminate knots and other defects that will interfere with attachment of other work.
- E. For furring strips for installing plywood or hardboard paneling, select boards with no knots capable of producing bent-over nails and damage to paneling.

2.9 FASTENERS

- A. General: Provide fasteners of size and type indicated that comply with requirements specified in this article for material and manufacture.
1. Where rough carpentry is exposed to weather, in ground contact, pressure-preservative treated, or in area of high relative humidity, provide fasteners with hot-dip zinc coating complying with ASTM A 153/A 153M.
- B. Nails, Brads, and Staples: ASTM F 1667.
- C. Power-Driven Fasteners: NES NER-272.
- D. Wood Screws: ASME B18.6.1.
- E. Lag Bolts: ASME B18.2.1.
- F. Bolts: Steel bolts complying with ASTM A 307, Grade A; with ASTM A 563 hex nuts and, where indicated, flat washers.
- G. Expansion Anchors: Anchor bolt and sleeve assembly of material indicated below with capability to sustain, without failure, a load equal to six times the load imposed when installed

in unit masonry assemblies and equal to four times the load imposed when installed in concrete as determined by testing per ASTM E 488 conducted by a qualified independent testing and inspecting agency.

1. Material: Carbon-steel components, zinc plated to comply with ASTM B 633, Class Fe/Zn 5.
2. Material: Stainless steel with bolts and nuts complying with ASTM F 593 and ASTM F 594, Alloy Group 1 or 2.

2.10 METAL FRAMING ANCHORS

- A. Basis-of-Design Product: Subject to compliance with requirements, provide product indicated on Drawings or approved substitute.
- B. Allowable Design Loads: Provide products with allowable design loads, as published by manufacturer, that meet or exceed those of basis-of-design products. Manufacturer's published values shall be determined from empirical data or by rational engineering analysis and demonstrated by comprehensive testing performed by a qualified independent testing agency.
- C. Materials:
 1. Interior Locations: Hot-dip, zinc-coated steel sheet complying with ASTM A 653/A 653M, G90 coating designation.
 2. Exterior Locations: Type 410 stainless steel.
 3. Interior Contact with Pressure-Treated Wood: A-Max G185 coating or better.

2.11 MISCELLANEOUS MATERIALS

- A. Sill-Sealer Gaskets: Closed-cell neoprene foam, 1/4 inch thick, selected from manufacturer's standard widths to suit width of sill members indicated.

PART 3 - EXECUTION

3.1 INSTALLATION, GENERAL

- A. Set rough carpentry to required levels and lines, with members plumb, true to line, cut, and fitted. Fit rough carpentry to other construction; scribe and cope as needed for accurate fit. Locate furring, nailers, blocking, and similar supports to comply with requirements for attaching other construction.
- B. Framing Standard: Comply with AF&PA's WCD 1, "Details for Conventional Wood Frame Construction," unless otherwise indicated.
- C. Framing with Engineered Wood Products: Install engineered wood products to comply with manufacturer's written instructions.
- D. Metal Framing Anchors: Install metal framing anchors to comply with manufacturer's written instructions. Install fasteners through each fastener hole.

BURBANK BRANCH RENOVATIONS, PORTLAND PUBLIC LIBRARY

- E. Install sill sealer gasket to form continuous seal between sill plates and foundation walls.
- F. Do not splice structural members between supports unless otherwise indicated.
- G. Provide blocking and framing as indicated and as required to support facing materials, fixtures, specialty items, and trim.
 - 1. Provide metal clips for fastening gypsum board or lath at corners and intersections where framing or blocking does not provide a surface for fastening edges of panels. Space clips not more than 16 inches o.c.
- H. Provide fire blocking in furred spaces, stud spaces, and other concealed cavities as indicated and as follows:
 - 1. Fire block furred spaces of walls, at each floor level, at ceiling, and at not more than 96 inches o.c. with solid wood blocking or noncombustible materials accurately fitted to close furred spaces.
 - 2. Fire block concealed spaces of wood-framed walls and partitions at each floor level, at ceiling line of top story, and at not more than 96 inches o.c. Where fire blocking is not inherent in framing system used, provide closely fitted solid wood blocks of same width as framing members and 2-inch nominal- thickness.
 - 3. Fire block concealed spaces between floor sleepers with same material as sleepers to limit concealed spaces to not more than 100 sq. ft. and to solidly fill space below partitions.
 - 4. Fire block concealed spaces behind combustible cornices and exterior trim at not more than 20 feet o.c.
- I. Sort and select lumber so that natural characteristics will not interfere with installation or with fastening other materials to lumber. Do not use materials with defects that interfere with function of member or pieces that are too small to use with minimum number of joints or optimum joint arrangement.
- J. Securely attach rough carpentry work to substrate by anchoring and fastening as indicated, complying with the following, unless shown otherwise on the drawings:
 - 1. NES NER-272 for power-driven fasteners.
 - 2. Table 2304.9.1, "Fastening Schedule," in ICC's International Building Code.
 - 3. Table R602.3(1), "Fastener Schedule for Structural Members," and Table R602.3(2), "Alternate Attachments," in ICC's International Residential Code for One- and Two-Family Dwellings.
- K. Use steel common nails with diameters as shown on the drawings unless otherwise indicated. Select fasteners of size that will not fully penetrate members where opposite side will be exposed to view or will receive finish materials. Make tight connections between members. Install fasteners without splitting wood. Drive nails snug but do not countersink nail heads unless otherwise indicated.

3.2 WOOD BLOCKING, AND NAILER INSTALLATION

- A. Install where indicated and where required for attaching other work. Form to shapes indicated and cut as required for true line and level of attached work. Coordinate locations with other work involved.
- B. Attach items to substrates to support applied loading. Recess bolts and nuts flush with surfaces unless otherwise indicated.
- C. Where wood-preserved-treated lumber is installed adjacent to metal decking, install continuous flexible flashing separator between wood and metal decking.

3.3 WOOD FURRING INSTALLATION

- A. Install level and plumb with closure strips at edges and openings. Shim with wood as required for tolerance of finish work.
- B. Furring to Receive Gypsum Board: Install 1-by-2-inch nominal- size furring vertically at 16 inches o.c.

3.4 WALL AND PARTITION FRAMING INSTALLATION

- A. General: Provide single bottom plate and double top plates using members of 2-inch nominal thickness whose widths equal that of studs, except single top plate may be used for non-load-bearing partitions. Fasten plates to supporting construction unless otherwise indicated.
 - 1. Provide continuous horizontal blocking at midheight of partitions more than 96 inches high, using members of 2-inch nominal thickness and of same width as wall or partitions.
- B. Construct corners and intersections with three or more studs, except that two studs may be used for interior non-load-bearing partitions.
- C. Frame openings with multiple studs and headers. Provide nailed header members of thickness equal to width of studs. Support headers on jamb studs.
 - 1. For non-load-bearing partitions, provide double-jamb studs and headers not less than 4-inch nominal depth for openings 48 inches and less in width, 6-inch nominal depth for openings 48 to 72 inches in width, 8-inch nominal depth for openings 72 to 120 inches in width, and not less than 10-inch nominal depth for openings 10 to 12 feet in width.
 - 2. For load-bearing walls, provide double-jamb studs for openings 60 inches and less in width, and triple-jamb studs for wider openings. Provide headers of depth indicated or, if not indicated, according to Table R502.5(1) or Table R502.5(2), as applicable, in ICC's International Residential Code for One- and Two-Family Dwellings.

3.5 FLOOR JOIST FRAMING INSTALLATION

- A. General: Install floor joists with crown edge up and support ends of each member with not less than 1-1/2 inches of bearing on wood or metal, or 3 inches on masonry. Attach floor joists as follows:

BURBANK BRANCH RENOVATIONS, PORTLAND PUBLIC LIBRARY

1. Where supported on wood members, by using metal framing anchors.
 2. Where framed into wood supporting members, by using wood ledgers as indicated or, if not indicated, by using metal joist hangers.
- B. Fire Cuts: At joists built into masonry, bevel cut ends 3 inches and do not embed more than 4 inches.
- C. Frame openings with headers and trimmers supported by metal joist hangers; double headers and trimmers where span of header exceeds 48 inches.
- D. Do not notch in middle third of joists; limit notches to one-sixth depth of joist. Do not bore holes larger than 1/3 depth of joist; do not locate closer than 2 inches from top or bottom.
- E. Provide solid blocking of 2-inch nominal thickness by depth of joist at ends of joists unless nailed to header or band.
- F. Lap members framing from opposite sides of beams, girders, or partitions not less than 4 inches or securely tie opposing members together. Provide solid blocking of 2-inch nominal thickness by depth of joist over supports.
- G. Anchor members paralleling masonry with 1/4-by-1-1/4-inch metal strap anchors spaced not more than 96 inches o.c., extending over and fastening to three joists. Embed anchors at least 4 inches into grouted masonry with ends bent at right angles and extending 4 inches beyond bend.
- H. Provide solid blocking between joists under jamb studs for openings.
- I. Under non-load-bearing partitions, provide double joists separated by solid blocking equal to depth of studs above.
1. Provide triple joists separated as above, under partitions receiving ceramic tile and similar heavy finishes or fixtures.
- J. Provide bridging of type indicated below, or full depth 2x solid blocking, at intervals of 96 inches o.c., between joists.
1. Diagonal wood bridging formed from bevel-cut, 1-by-3-inch nominal- size lumber, double-crossed and nailed at both ends to joists.
 2. Steel bridging installed to comply with bridging manufacturer's written instructions.

3.6 WOOD STRUCTURAL PANEL INSTALLATION

- A. General: Comply with applicable recommendations in APA Form No. E30S, "Engineered Wood Construction Guide," for types of structural-use panels and applications indicated.
- B. Fastening Methods: Fasten panels as indicated below:
1. Subflooring:
 - a. Glue and nail to wood framing.
 - b. Space panels 1/8 inch apart at edges and ends.

BURBANK BRANCH RENOVATIONS, PORTLAND PUBLIC LIBRARY

2. Wall Sheathing:
 - a. Nail to wood framing.
 - b. Space panels 1/8 inch apart at edges and ends.
3. Underlayment: Install in accordance with manufacturer's recommendations.
 - a. Nail to subflooring, 2 inches on center along edges and 4 inches on center in the field.
 - b. Butt panels together at edges and ends.
 - c. Leave 1/4 to 1/2inch gap at walls.
 - d. Fill and sand edge joints of underlayment receiving resilient flooring right before installing flooring.

END OF SECTION 061000

SECTION 062013 - EXTERIOR FINISH CARPENTRY

PART 1 - GENERAL

1.1 RELATED DOCUMENTS

- A. Drawings and general provisions of the Contract, including General and Supplementary Conditions and Division 01 Specification Sections, apply to this Section.

1.2 SUMMARY

- A. Section Includes:
 - 1. Exterior standing and running trim.
 - 2. Plywood siding.

1.3 ACTION SUBMITTALS

- A. Product Data: For each type of process and factory-fabricated product. Indicate component materials, dimensions, profiles, textures, and colors and include construction and application details.

1.4 DELIVERY, STORAGE, AND HANDLING

- A. Stack lumber, plywood, and other panels flat with spacers between each bundle to provide air circulation. Protect materials from weather by covering with waterproof sheeting, securely anchored. Provide for air circulation around stacks and under coverings.

1.5 FIELD CONDITIONS

- A. Weather Limitations: Proceed with installation only when existing and forecast weather conditions permit work to be performed and at least one coat of specified finish can be applied without exposure to rain, snow, or dampness.
 - 1. For exterior ornamental wood columns, comply with manufacturer's written instructions and warranty requirements.
- B. Do not install finish carpentry materials that are wet, moisture damaged, or mold damaged.
 - 1. Indications that materials are wet or moisture damaged include, but are not limited to, discoloration, sagging, or irregular shape.
 - 2. Indications that materials are mold damaged include, but are not limited to, fuzzy or splotchy surface contamination and discoloration.

PART 2 - PRODUCTS

2.1 MATERIALS, GENERAL

- A. Lumber: DOC PS 20 and the following grading rules:
 - 1. NeLMA: Northeastern Lumber Manufacturers' Association, "Standard Grading Rules for Northeastern Lumber."
 - 2. NLGA: National Lumber Grades Authority, "Standard Grading Rules for Canadian Lumber."
 - 3. RIS: Redwood Inspection Service, "Standard Specifications for Grades of California Redwood Lumber."
 - 4. SPIB: The Southern Pine Inspection Bureau, "Standard Grading Rules for Southern Pine Lumber."
 - 5. WCLIB: West Coast Lumber Inspection Bureau, Standard No. 17, "Grading Rules for West Coast Lumber."
 - 6. WWPA: Western Wood Products Association, "Western Lumber Grading Rules."
- B. Factory mark each piece of lumber with grade stamp of inspection agency indicating grade, species, moisture content at time of surfacing, and mill.
 - 1. For exposed lumber, mark grade stamp on end or back of each piece, or omit grade stamp and provide certificates of grade compliance issued by inspection agency.
- C. Softwood Plywood: DOC PS 1.

2.2 STANDING AND RUNNING TRIM

- A. Lumber Trim for Painted Finish:
 - 1. Species and Grade: Eastern white pine, eastern hemlock-balsam fir-tamarack, eastern spruce, or white woods; Finish or No. 2; NeLMA, NLGA, WCLIB, or WWPA.
 - 2. Maximum Moisture Content: 15 percent.
 - 3. Finger Jointing: Not allowed.
 - 4. Face Surface: Surfaced (smooth).
- B. MDO Siding Panels: Exterior Grade B-B, MDO plywood.

2.3 MISCELLANEOUS MATERIALS

- A. Fasteners for Exterior Finish Carpentry: Provide nails or screws, in sufficient length to penetrate not less than 1-1/2 inches into wood substrate.
 - 1. For face-fastening siding, provide ringed-shank siding nails or hot-dip galvanized-steel siding nails.
- B. Horizontal Joint Flashing for MDO Siding: Preformed, prefinished-aluminum, Z-shaped flashing.

BURBANK BRANCH RENOVATIONS, PORTLAND PUBLIC LIBRARY

2.4 FABRICATION

- A. Ease edges of lumber less than 1 inch in nominal thickness to 1/16-inch radius and edges of lumber 1 inch or more in nominal thickness to 1/8-inch radius.

PART 3 - EXECUTION

3.1 EXAMINATION

- A. Examine substrates, with Installer present, for compliance with requirements for installation tolerances and other conditions affecting performance.
- B. Examine finish carpentry materials before installation. Reject materials that are wet, moisture damaged, and mold damaged.
- C. Proceed with installation only after unsatisfactory conditions have been corrected.

3.2 PREPARATION

- A. Clean substrates of projections and substances detrimental to application.
- B. Prime lumber and moldings to be painted, including both faces and edges, unless factory primed. Cut to required lengths and prime ends. Comply with requirements in Section 099113 "Exterior Painting."

3.3 INSTALLATION, GENERAL

- A. Do not use materials that are unsound, warped, improperly treated or finished, inadequately seasoned, or too small to fabricate with proper jointing arrangements.
 - 1. Do not use manufactured units with defective surfaces, sizes, or patterns.
- B. Install exterior finish carpentry level, plumb, true, and aligned with adjacent materials. Use concealed shims where necessary for alignment.
 - 1. Scribe and cut exterior finish carpentry to fit adjoining work. Refinish and seal cuts as recommended by manufacturer.
 - 2. Install to tolerance of 1/8 inch in 96 inches for level and plumb. Install adjoining exterior finish carpentry with 1/32-inch maximum offset for flush installation and 1/16-inch maximum offset for reveal installation.
 - 3. Coordinate exterior finish carpentry with materials and systems in or adjacent to it. Provide cutouts for mechanical and electrical items that penetrate exterior finish carpentry.

3.4 STANDING AND RUNNING TRIM INSTALLATION

- A. Install flat-grain lumber with bark side exposed to weather.

BURBANK BRANCH RENOVATIONS, PORTLAND PUBLIC LIBRARY

- B. Install trim with minimum number of joints practical, using full-length pieces from maximum lengths of lumber available. Do not use pieces less than 24 inches long except where necessary.
 - 1. Use scarf joints for end-to-end joints.
 - 2. Stagger end joints in adjacent and related members.
- C. Fit exterior joints to exclude water. Cope at returns and miter at corners to produce tight-fitting joints with full-surface contact throughout length of joint. Plane backs of casings to provide uniform thickness across joints, where necessary for alignment.
- D. Where face fastening is unavoidable, countersink fasteners, fill surface flush, and sand unless otherwise indicated.

3.5 SIDING INSTALLATION

- A. Plywood Siding: Install panels with edges over framing or blocking. Nail at 6 inches o.c. at panel perimeter and 12 inches o.c. at intermediate supports unless manufacturer recommends closer spacing. Leave 1/16-inch gap between adjacent panels and 1/8-inch gap at perimeter, openings, and horizontal joints unless otherwise recommended by panel manufacturer.
 - 1. Seal butt joints at inside and outside corners and at trim locations.
 - 2. Install continuous metal flashing at horizontal panel joints.
 - 3. Apply battens and corner trim as indicated.
- B. Flashing: Install metal flashing as indicated on Drawings and as recommended by siding manufacturer.

3.6 ADJUSTING

- A. Replace exterior finish carpentry that is damaged or does not comply with requirements. Exterior finish carpentry may be repaired or refinished if work complies with requirements and shows no evidence of repair or refinishing. Adjust joinery for uniform appearance.

3.7 CLEANING

- A. Clean exterior finish carpentry on exposed and semiexposed surfaces. Touch up factory-applied finishes to restore damaged or soiled areas.

3.8 PROTECTION

- A. Protect installed products from damage from weather and other causes during construction.
- B. Remove and replace finish carpentry materials that are wet, moisture damaged, and mold damaged.
 - 1. Indications that materials are wet or moisture damaged include, but are not limited to, discoloration, sagging, or irregular shape.

BURBANK BRANCH RENOVATIONS, PORTLAND PUBLIC LIBRARY

2. Indications that materials are mold damaged include, but are not limited to, fuzzy or splotchy surface contamination and discoloration.

END OF SECTION 062013

SECTION 064023 - INTERIOR ARCHITECTURAL WOODWORK

PART 1 - GENERAL

1.1 RELATED DOCUMENTS

- A. Drawings and general provisions of the Contract, including General and Supplementary Conditions and Division 01 Specification Sections, apply to this Section.

1.2 SUMMARY

- A. This Section includes the following:

1. Interior standing and running trim.
2. Wood casework.
3. Solid-surfacing-material countertops.
4. Shop finishing of interior woodwork.

- B. Related Sections include the following:

1. Division 06 Section "Rough Carpentry" for wood furring, blocking, shims, and hanging strips required for installing woodwork and concealed within other construction before woodwork installation.

1.3 DEFINITIONS

- A. Interior architectural woodwork includes wood furring, blocking, shims, and hanging strips for installing woodwork items unless concealed within other construction before woodwork installation.

1.4 ACTION SUBMITTALS

- A. Product Data: For panel products high-pressure decorative laminate adhesive for bonding plastic laminate solid-surfacing material cabinet hardware and accessories and finishing materials and processes.

- B. Shop Drawings: Show location of each item, dimensioned plans and elevations, large-scale details, attachment devices, and other components.

1. Show details full size.
2. Show locations and sizes of furring, blocking, and hanging strips, including concealed blocking and reinforcement specified in other Sections.
3. Show locations and sizes of cutouts and holes for plumbing fixtures and other items installed in architectural woodwork.
4. Show veneer leaves with dimensions, grain direction, exposed face, and identification numbers indicating the flitch and sequence within the flitch for each leaf.

C. Samples for Initial Selection:

1. Shop-applied transparent finishes.
2. Plastic laminates.
3. PVC edge material.
4. Thermoset decorative panels.
5. Solid-surfacing materials.

D. Samples for Verification:

1. Lumber with or for transparent finish, not less than 50 sq. in. or 5 inches wide by 24 inches long, for each species and cut, finished on 1 side and 1 edge.
2. Veneer-faced panel products with or for transparent finish, 8 by 10 inches, for each species and cut. Include at least one face-veneer seam and finish as specified.
3. Lumber and panel products with shop-applied opaque finish, 50 sq. in. for lumber and 8 by 10 inches for panels, for each finish system and color, with 1/2 of exposed surface finished.
4. Plastic laminates, 8 by 10 inches, for each type, color, pattern, and surface finish.
5. Thermoset decorative-panels, 8 by 10 inches, for each type, color, pattern, and surface finish.
6. Solid-surfacing materials, 6 inches square.
7. Exposed cabinet hardware and accessories, one unit for each type and finish.

1.5 QUALITY ASSURANCE

- A. Quality Standard: Unless otherwise indicated, comply with AWI's "Architectural Woodwork Quality Standards" for grades of interior architectural woodwork indicated for construction, finishes, installation, and other requirements.
1. The Contract Documents contain selections chosen from options in the quality standard and additional requirements beyond those of the quality standard. Comply with such selections and requirements in addition to the quality standard.
- B. Preinstallation Conference: Conduct conference at Project site to comply with requirements in Division 01 Section "Project Management and Coordination."

1.6 DELIVERY, STORAGE, AND HANDLING

- A. Do not deliver woodwork until painting and similar operations that could damage woodwork have been completed in installation areas. If woodwork must be stored in other than installation areas, store only in areas where environmental conditions comply with requirements specified in "Project Conditions" Article.

1.7 PROJECT CONDITIONS

- A. Environmental Limitations: Do not deliver or install woodwork until building is enclosed, wet work is complete, and HVAC system is operating and maintaining temperature and relative humidity at occupancy levels during the remainder of the construction period.

BURBANK BRANCH RENOVATIONS, PORTLAND PUBLIC LIBRARY

- B. Field Measurements: Where woodwork is indicated to fit to other construction, verify dimensions of other construction by field measurements before fabrication, and indicate measurements on Shop Drawings. Coordinate fabrication schedule with construction progress to avoid delaying the Work.
 - 1. Locate concealed framing, blocking, and reinforcements that support woodwork by field measurements before being enclosed, and indicate measurements on Shop Drawings.
 - 2. Established Dimensions: Where field measurements cannot be made without delaying the Work, establish dimensions and proceed with fabricating woodwork without field measurements. Provide allowance for trimming at site, and coordinate construction to ensure that actual dimensions correspond to established dimensions.

1.8 COORDINATION

- A. Coordinate sizes and locations of framing, blocking, furring, reinforcements, and other related units of Work specified in other Sections to ensure that interior architectural woodwork can be supported and installed as indicated.

PART 2 - PRODUCTS

2.1 MATERIALS

- A. General: Provide materials that comply with requirements of AWI's quality standard for each type of woodwork and quality grade specified, unless otherwise indicated.
- B. Wood Species and Cut for Transparent Finish: **[White oak, rift sawn]**
- C. Wood Products: Comply with the following:
 - 1. Medium-Density Fiberboard: ANSI A208.2, Grade MD.
 - 2. Particleboard: ANSI A208.1, Grade M-2.
 - 3. Veneer-Faced Panel Products (Hardwood Plywood): HPVA HP-1.
- D. Solid-Surfacing Material: Homogeneous solid sheets of filled plastic resin complying with ISSFA-2.
 - 1. Available Manufacturers: Subject to compliance with requirements, manufacturers offering products that may be incorporated into the Work include, but are not limited to, the following:
 - a. Avonite, Inc.
 - b. E. I. du Pont de Nemours and Company.
 - c. Formica Corporation.
 - d. Nevamar Company, LLC; Decorative Products Div.
 - e. Swan Corporation (The).
 - f. Wilsonart International; Div. of Premark International, Inc.
 - 2. Type: Standard type, unless Special Purpose type is indicated.
 - 3. Colors and Patterns: As selected by Architect from manufacturer's full range.

2.2 CABINET HARDWARE AND ACCESSORIES

- A. General: Provide cabinet hardware and accessory materials associated with architectural cabinets, except for items specified in Division 08 Section "Door Hardware (Scheduled by Describing Products)."
- B. Frameless Concealed Hinges (European Type): BHMA A156.9, B01602, 100 degrees of opening, self-closing.
 - 1. Available Products:
 - a. Blum: BH75T1550.
 - b. Grass: GHA3703M.
 - c. MEPLA: CS04 (MH146304550015).
- C. Pulls: Drawer Pull by Brunner Enterprises, Inc.; anodized aluminum finish.
- D. Shelf Rests: BHMA A156.9, B04013; plastic, two-pin type with shelf hold-down clip.
 - 1. Plastic double pin shelf clip: Provide 1/4 inch diameter hole, clear or white color as selected by the Architect.
 - a. Available Products:
 - 1) Hardware Concepts, Inc.: Series 5033.
 - 2) AllenField: No. 55 Double Pin.
- E. Counter Support Brackets: Provide one of the following
 - 1. Heavy gage aluminum angle, MIG welded corners, 5/16 inch holes for mounting, and primed finish for field painting. Provide Rakks Counter Support, Model No. EH-[1818,] [1824,] by Ragine Corporation (800-826-6006) or approved substitution.
- F. Grommets for Cable Passage through Countertops: 3-inch OD, black, molded-plastic grommets and matching plastic caps with slot for wire passage.
 - 1. Product: Provide No. 35-3" by Outwater Plastics, Woodridge, NJ, (800) 631-8375.
- G. Exposed Hardware Finishes: For exposed hardware, provide finish that complies with BHMA A156.18 for BHMA finish number indicated.
 - 1. Satin Chromium Plated: BHMA 626 for brass or bronze base; BHMA 652 for steel base.
 - 2. Satin Stainless Steel: BHMA 630.
- H. For concealed hardware, provide manufacturer's standard finish that complies with product class requirements in BHMA A156.9.

2.3 MISCELLANEOUS MATERIALS

- A. Furring, Blocking, Shims, and Hanging Strips: Softwood or hardwood lumber, kiln dried to less than 15 percent moisture content.

BURBANK BRANCH RENOVATIONS, PORTLAND PUBLIC LIBRARY

- B. Furring, Blocking, Shims, and Hanging Strips: Fire-retardant-treated softwood lumber, kiln dried to less than 15 percent moisture content.
- C. Anchors: Select material, type, size, and finish required for each substrate for secure anchorage. Provide nonferrous-metal or hot-dip galvanized anchors and inserts on inside face of exterior walls and elsewhere as required for corrosion resistance. Provide toothed-steel or lead expansion sleeves for drilled-in-place anchors.
- D. Adhesives, General: Do not use adhesives that contain urea formaldehyde.
- E. VOC Limits for Installation Adhesives and Glues: Use installation adhesives that comply with the following limits for VOC content when calculated according to 40 CFR 59, Subpart D (EPA Method 24):
 - 1. Wood Glues: 30 g/L.
 - 2. Contact Adhesive: 250 g/L.

2.4 FABRICATION, GENERAL

- A. Interior Woodwork Grade: Unless otherwise indicated, provide Custom-grade interior woodwork complying with referenced quality standard.
- B. Wood Moisture Content: Comply with requirements of referenced quality standard for wood moisture content in relation to ambient relative humidity during fabrication and in installation areas.
- C. Fabricate woodwork to dimensions, profiles, and details indicated. Ease edges to radius indicated for the following:
 - 1. Corners of Cabinets and Edges of Solid-Wood (Lumber) Members 3/4 Inch Thick or Less: 1/16 inch.
 - 2. Edges of Rails and Similar Members More Than 3/4 Inch Thick: 1/8 inch.
 - 3. Corners of Cabinets and Edges of Solid-Wood (Lumber) Members and Rails: 1/16 inch.
- D. Complete fabrication, including assembly, finishing, and hardware application, to maximum extent possible before shipment to Project site. Disassemble components only as necessary for shipment and installation. Where necessary for fitting at site, provide ample allowance for scribing, trimming, and fitting.
 - 1. Trial fit assemblies at fabrication shop that cannot be shipped completely assembled. Install dowels, screws, bolted connectors, and other fastening devices that can be removed after trial fitting. Verify that various parts fit as intended and check measurements of assemblies against field measurements indicated on Shop Drawings before disassembling for shipment.
- E. Shop-cut openings to maximum extent possible to receive hardware, appliances, plumbing fixtures, electrical work, and similar items. Locate openings accurately and use templates or roughing-in diagrams to produce accurately sized and shaped openings. Sand edges of cutouts to remove splinters and burrs.

BURBANK BRANCH RENOVATIONS, PORTLAND PUBLIC LIBRARY

1. Seal edges of openings in countertops with a coat of varnish.

2.5 INTERIOR STANDING AND RUNNING TRIM FOR OPAQUE FINISH

- A. Wood Species: Eastern white pine or poplar.
- B. Backout or groove backs of flat trim members and kerf backs of other wide, flat members, except for members with ends exposed in finished work.
- C. Assemble casings in plant except where limitations of access to place of installation require field assembly.
- D. Assemble moldings in plant to maximum extent possible. Miter corners in plant and prepare for field assembly with bolted fittings designed to pull connections together.
- E. Colors, Patterns, and Finishes: Provide materials and products that result in colors and textures of exposed laminate surfaces complying with the following requirements:
 1. As selected by Architect from laminate manufacturer's full range in the following categories:
 - a. Solid colors, matte finish.
 - b. Patterns, matte finish.

2.6 SOLID-SURFACING-MATERIAL COUNTERTOPS (Public Computing Desks)

- A. Grade: Premium.
- B. Solid-Surfacing-Material Thickness: 1/2 inch.
- C. Colors, Patterns, and Finishes: Provide materials and products that result in colors of solid-surfacing material complying with the following requirements:
 1. As selected by Architect from manufacturer's full range.
- D. Fabricate tops in one piece, unless otherwise indicated. Comply with solid-surfacing-material manufacturer's written recommendations for adhesives, sealers, fabrication, and finishing.
 1. Fabricate tops with shop-applied edges of materials and configuration indicated.
 2. Fabricate tops with shop-applied backsplashes.

2.7 SHOP FINISHING

- A. Grade: Provide finishes of same grades as items to be finished.
- B. General: Finish architectural woodwork at fabrication shop as specified in this Section. Defer only final touchup, cleaning, and polishing until after installation.

BURBANK BRANCH RENOVATIONS, PORTLAND PUBLIC LIBRARY

- C. Preparation for Finishing: Comply with referenced quality standard for sanding, filling countersunk fasteners, sealing concealed surfaces, and similar preparations for finishing architectural woodwork, as applicable to each unit of work.
 - 1. Backpriming: Apply one coat of sealer or primer, compatible with finish coats, to concealed surfaces of woodwork. Apply two coats to back of paneling and to end-grain surfaces. Concealed surfaces of plastic-laminate-clad woodwork do not require backpriming when surfaced with plastic laminate, backing paper, or thermoset decorative panels.
- D. Transparent Finish:
 - 1. Grade: Custom.
 - 2. AWI Finish System TR-5: Catalyzed vinyl.
 - 3. Staining: None required.
 - 4. Open Finish for Open-Grain Woods: Do not apply filler to open-grain woods.
 - 5. Sheen: Satin, 30-50 gloss units.

PART 3 - EXECUTION

3.1 PREPARATION

- A. Before installation, condition woodwork to average prevailing humidity conditions in installation areas.
- B. Before installing architectural woodwork, examine shop-fabricated work for completion and complete work as required, including removal of packing and backpriming.

3.2 INSTALLATION

- A. Grade: Install woodwork to comply with requirements for the same grade specified in Part 2 for fabrication of type of woodwork involved.
- B. Assemble woodwork and complete fabrication at Project site to comply with requirements for fabrication in Part 2, to extent that it was not completed in the shop.
- C. Install woodwork level, plumb, true, and straight. Shim as required with concealed shims. Install level and plumb (including tops) to a tolerance of 1/8 inch in 96 inches.
- D. Scribe and cut woodwork to fit adjoining work, refinish cut surfaces, and repair damaged finish at cuts.
- E. Anchor woodwork to anchors or blocking built in or directly attached to substrates. Secure with countersunk, concealed fasteners and blind nailing as required for complete installation. Use fine finishing nails for exposed fastening, countersunk and filled flush with woodwork and matching final finish if transparent finish is indicated.

BURBANK BRANCH RENOVATIONS, PORTLAND PUBLIC LIBRARY

- F. Standing and Running Trim: Install with minimum number of joints possible, using full-length pieces (from maximum length of lumber available) to greatest extent possible. Do not use pieces less than 36 inches long, except where shorter single-length pieces are necessary.
1. Fill gaps, if any, between top of base and wall with plastic wood filler, sand smooth, and finish same as wood base if finished.
 2. Install wall railings on indicated metal brackets securely fastened to wall framing.
 3. Install standing and running trim with no more variation from a straight line than 1/8 inch in 96 inches.
- G. Countertops: Anchor securely by screwing through corner blocks of base cabinets or other supports into underside of countertop.
1. Align adjacent solid-surfacing-material countertops and form seams to comply with manufacturer's written recommendations using adhesive in color to match countertop. Carefully dress joints smooth, remove surface scratches, and clean entire surface.
 2. Install countertops with no more than 1/8 inch in 96-inch sag, bow, or other variation from a straight line.
 3. Secure backsplashes to walls with adhesive.
 4. Calk space between backsplash and wall with sealant specified in Division 07 Section "Joint Sealants."
- H. Touch up finishing work specified in this Section after installation of woodwork. Fill nail holes with matching filler where exposed.

3.3 ADJUSTING AND CLEANING

- A. Repair damaged and defective woodwork, where possible, to eliminate functional and visual defects; where not possible to repair, replace woodwork. Adjust joinery for uniform appearance.
- B. Clean woodwork on exposed and semiexposed surfaces. Touch up shop-applied finishes to restore damaged or soiled areas.

END OF SECTION 064023

SECTION 072100 - THERMAL INSULATION

PART 1 - GENERAL

1.1 RELATED DOCUMENTS

- A. Drawings and general provisions of the Contract, including General and Supplementary Conditions and Division 01 Specification Sections, apply to this Section.

1.2 SUMMARY

- A. This Section includes the following:
 - 1. Glass-fiber blanket insulation.
 - 2. Spray polyurethane foam insulation.
 - 3. Vapor retarders.

1.3 ACTION SUBMITTALS

- A. Product Data: For each type of product indicated.

1.4 INFORMATIONAL SUBMITTALS

- A. Product Test Reports: Based on evaluation of comprehensive tests performed by a qualified testing agency for insulation products.

1.5 QUALITY ASSURANCE

- A. Source Limitations: Obtain each type of building insulation through one source from a single manufacturer.
- B. Surface-Burning Characteristics: As determined by testing identical products according to ASTM E 84 by a qualified testing agency. Identify products with appropriate markings of applicable testing agency.

1.6 DELIVERY, STORAGE, AND HANDLING

- A. Protect insulation materials from physical damage and from deterioration by moisture, soiling, and other sources. Store inside and in a dry location. Comply with manufacturer's written instructions for handling, storing, and protecting during installation.

PART 2 - PRODUCTS

2.1 MANUFACTURERS

- A. In other Part 2 articles where titles below introduce lists, the following requirements apply to product selection:
 - 1. Available Products: Subject to compliance with requirements, products that may be incorporated into the Work include, but are not limited to, products specified.
 - 2. Available Manufacturers: Subject to compliance with requirements, manufacturers offering products that may be incorporated into the Work include, but are not limited to, manufacturers specified.

2.2 GLASS-FIBER BLANKET INSULATION

- A. Available Manufacturers:
 - 1. CertainTeed Corporation. (20% recycled content)
 - 2. Guardian Fiberglass, Inc. (30% post consumer, 5% post industrial)
 - 3. Johns Manville. (18% post consumer, 7% post industrial)
 - 4. Knauf Fiber Glass. (recycled content NA)
 - 5. Owens Corning. (40% recycled content)
- B. Unfaced, Glass-Fiber Blanket Insulation: ASTM C 665, Type I (blankets without membrane facing); consisting of fibers; with maximum flame-spread and smoke-developed indexes of 25 and 50, respectively; passing ASTM E 136 for combustion characteristics.

2.3 SPRAYED FOAM INSULATION

- A. Sprayed Polyurethane Foam Sealant for Perimeter of Doors and Windows: 1- or 2-component, foamed-in-place, polyurethane foam sealant, 1.5 to 2.0 lb/cu. ft. density; flame spread index of 25 or less according to ASTM E 162; with primer and noncorrosive substrate cleaner recommended by foam sealant manufacturer.
 - 1. Products:
 - a. Great Stuff Window & Door by Dow
 - b. Froth-Pak by Insta-Foam Products, Inc.
 - c. Zerodraft Insulating Air Sealant by Zerodraft.

2.4 VAPOR RETARDERS

- A. Polyethylene Vapor Retarders: ASTM D 4397, 6 mils thick, with maximum permeance rating of 0.13 perm.
- B. Vapor-Retarder Tape: Pressure-sensitive tape of type recommended by vapor-retarder manufacturer for sealing joints and penetrations in vapor retarder.

BURBANK BRANCH RENOVATIONS, PORTLAND PUBLIC LIBRARY

- C. Vapor-Retarder Fasteners: Pancake-head, self-tapping steel drill screws; with fender washers.
- D. Single-Component Nonsag Urethane Sealant: ASTM C 920, Type I, Grade NS, Class 25, Use NT related to exposure, and Use O related to vapor-barrier-related substrates.
- E. Adhesive for Vapor Retarders: Product recommended by vapor-retarder manufacturer and with demonstrated capability to bond vapor retarders securely to substrates indicated.

PART 3 - EXECUTION

3.1 EXAMINATION

- A. Examine substrates and conditions, with Installer present, for compliance with requirements of Sections in which substrates and related work are specified and for other conditions affecting performance.
 - 1. Proceed with installation only after unsatisfactory conditions have been corrected.

3.2 PREPARATION

- A. Clean substrates of substances harmful to insulation or vapor retarders, including removing projections capable of puncturing vapor retarders or of interfering with insulation attachment.

3.3 INSTALLATION, GENERAL

- A. Comply with insulation manufacturer's written instructions applicable to products and application indicated.
- B. Install insulation that is undamaged, dry, and unsoiled and that has not been left exposed at any time to ice, rain, and snow.
- C. Extend insulation in thickness indicated to envelop entire area to be insulated. Cut and fit tightly around obstructions and fill voids with insulation. Remove projections that interfere with placement.
- D. Water-Piping Coordination: If water piping is located within insulated exterior walls, coordinate location of piping to ensure that it is placed on warm side of insulation and insulation encapsulates piping.
- E. For preformed insulating units, provide sizes to fit applications indicated and selected from manufacturer's standard thicknesses, widths, and lengths. Apply single layer of insulation units to produce thickness indicated unless multiple layers are otherwise shown or required to make up total thickness.

3.4 INSTALLATION OF GENERAL BUILDING INSULATION

- A. Apply insulation units to substrates by method indicated, complying with manufacturer's written instructions. If no specific method is indicated, bond units to substrate with adhesive or use mechanical anchorage to provide permanent placement and support of units.
- B. Install mineral-fiber insulation in cavities formed by framing members according to the following requirements:
 - 1. Use insulation widths and lengths that fill the cavities formed by framing members. If more than one length is required to fill cavity, provide lengths that will produce a snug fit between ends.
 - 2. Place insulation in cavities formed by framing members to produce a friction fit between edges of insulation and adjoining framing members.
 - 3. Maintain 3-inch clearance of insulation around recessed lighting fixtures.
- C. Apply foamed-in-place insulation, by spray or froth method to a uniform monolithic density without voids into miscellaneous voids and cavity spaces where shown.

3.5 INSTALLATION OF VAPOR RETARDERS

- A. General: Extend vapor retarder to extremities of areas to be protected from vapor transmission. Secure in place with adhesives or other anchorage system as indicated. Extend vapor retarder to cover miscellaneous voids in insulated substrates, including those filled with loose-fiber insulation.
- B. Seal vertical joints in vapor retarders over framing by lapping not less than two wall studs. Fasten vapor retarders to wood framing at top, end, and bottom edges; at perimeter of wall openings; and at lap joints. Space fasteners 16 inches o.c.
- C. Before installing vapor retarder, apply urethane sealant to flanges of metal framing including runner tracks, metal studs, and framing around door and window openings. Seal overlapping joints in vapor retarders with vapor-retarder tape according to vapor-retarder manufacturer's written instructions. Seal butt joints with vapor-retarder tape. Locate all joints over framing members or other solid substrates.
- D. Firmly attach vapor retarders to metal framing and solid substrates with vapor-retarder fasteners as recommended by vapor-retarder manufacturer.
- E. Seal joints caused by pipes, conduits, electrical boxes, and similar items penetrating vapor retarders with vapor-retarder tape to create an airtight seal between penetrating objects and vapor retarder.
- F. Repair tears or punctures in vapor retarders immediately before concealment by other work. Cover with vapor-retarder tape or another layer of vapor retarder.

3.6 PROTECTION

- A. Protect installed insulation and vapor retarders from damage due to harmful weather exposures, physical abuse, and other causes. Provide temporary coverings or enclosures where insulation is subject to abuse and cannot be concealed and protected by permanent construction immediately after installation.

END OF SECTION 072100

SECTION 072616 - BELOW-GRADE VAPOR RETARDERS

PART 1 - GENERAL

1.1 RELATED DOCUMENTS

- A. Drawings and general provisions of the Contract, including General and Supplementary Conditions and Division 01 Specification Sections, apply to this Section.

1.2 SUMMARY

- A. This Section includes the following:
 - 1. Vapor retarders under slabs-on-grade.

1.3 DEFINITIONS

- A. Vapor Retarder: Material with a water vapor transmission rating of not over 0.04g per square foot per hour.
- B. Vapor Barrier: Material with a water vapor transmission rating of not over 0.015g per square foot per hour.

1.4 SUBMITTALS

- A. Product Data: For each type of product indicated.
- B. Samples for Verification: 12 inch square units for each type of vapor retarder, vapor barrier, or air barrier indicated.

1.5 DELIVERY, STORAGE, AND HANDLING

- A. Protect materials from physical damage and from deterioration by moisture, soiling, and other sources. Store inside and in a dry location. Comply with manufacturer's written instructions for handling, storing, and protecting during installation.

1.6 PROJECT CONDITIONS

- A. Separate and recycle waste materials.

PART 2 - PRODUCTS

2.1 MANUFACTURERS

- A. Available Manufacturers and Products: Subject to compliance with requirements, manufacturers offering products that may be incorporated into the Work include, but are not limited to, the following products listed in Part 2 of this Section.

2.2 VAPOR RETARDERS FOR UNDER SLABS

- A. Vapor Retarder with extremely low permeance for critically sensitive, low permeance floor coverings such as rubber, vinyl, urethane, epoxy and methyl methacrylate, as well as linoleum and wood, having the following qualities:
 - 1. Minimum Permeance: ASTM E-96, not greater than 0.01 perms.
 - 2. Tensile Strength: ASTM E154 or D638, Class A – over 45 lbf/in.
 - 3. Puncture Resistance: ASTM E-154, Class B – over 1700 grams.
 - 4. Water Vapor Barrier: ASTM E-1745, meets or exceeds Class B.
 - 5. Thickness of Barrier (Plastic) ACI 302.1R-96, not less than 15 mils.
- B. Available Products: Subject to compliance with requirements, products that may be incorporated into the Work include, but are not limited to, the following:
 - 1. Stego Wrap, 15 mil thick vapor retarder by Stego Industries LLC, (877) 464-7834.
 - 2. Griffolyn® 15 by Reef Industries.
 - 3. Sealtight Perminator 15 mil Underslab Vapor-Mat by W.R. Meadows, Inc.
 - 4. Viper VaporCheck 16 by Insulation Solutions, Inc.
- C. Vapor-Retarder Tape (for slabs): Stego Warp red polyethylene tape or tape as recommended by the manufacturer.
- D. Double-Stick Edge Tape: Preformed 1-1/2" wide two-sided adhesive. Available products include "Fab Tape" by Reef Industries.
- E. Expansion Joint Filler: Installer may elect to use Deck-O-Foam Expansion Joint Filler by WR Meadows or equal. Foam expansion joint filler with pre-scored removable strip for installation of joint sealant.

PART 3 - EXECUTION

3.1 EXAMINATION

- A. Examine substrates and conditions, with Installer present, for compliance with requirements for Sections in which substrates and related work are specified and other conditions affecting performance.

BURBANK BRANCH RENOVATIONS, PORTLAND PUBLIC LIBRARY

- B. Proceed with installation only after unsatisfactory conditions have been corrected.

3.2 PREPARATION

- A. Clean substrates of substances harmful to vapor retarders, including removing projections capable of puncturing vapor retarders, or of interfering with attachment.
- B. Do not install carpet over concrete slabs until slabs have cured and are sufficiently dry to bond with adhesive and concrete slabs have pH range recommended by carpet manufacturer.

3.3 INSTALLATION, GENERAL

- A. Comply with manufacturer's written instructions applicable to products and application indicated.
- B. Extend retarders in thickness indicated to envelop entire area to be covered. Cut and fit tightly around obstructions. Remove projections that interfere with placement.

3.4 INSTALLATION OF UNDER-SLAB VAPOR RETARDERS

- A. Moisture vapor retarder system shall be installed at all interior floor slabs and as otherwise indicated in the drawings in strict accordance with the manufacturer's printed instructions and as follows:
 1. Snap chalk line along inside perimeter of foundation walls at top of slab elevation.
 2. Without wetting, clean a 3" wide band on the surface of the concrete below the chalk line at approximately mid-slab height. Remove dirt, residual form release, or other bond inhibiting surface contaminants. Grind smooth any surface projections within the band.
 3. While removing the contact paper on the backside, firmly press 2" wide double-stick edge tape onto wall, parallel to the chalk line on the cleaned band at mid-slab elevation.
 4. Remove contact paper on the face side.
 5. Apply a 12" wide strip of vapor retarder covering only the bottom 1" of contact surface on the edge tape. Cut, fit, and seal corner details with vapor retarder seaming tape.
 6. Align top edge of Deck-O-Foam expansion joint material to chalk line, and press material onto remaining 1" of exposed perimeter strip adhesive.
 7. Roll out vapor retarder material, overlapping edge rolls and all seams by 3". Tape all seams with vapor retarder seaming tape.
 8. All tears, punctures, etc. to be repaired and taped as required to maintain the watertight integrity of the vapor retarder system.

3.5 PROTECTION

- A. Protect installed vapor retarders from damage due to harmful weather exposures, physical abuse, and other causes. Provide temporary coverings or enclosures where vapor retarders are subject to abuse and cannot be concealed and protected by permanent construction immediately after installation.

END OF SECTION 072616

SECTION 078413 - PENETRATION FIRESTOPPING

PART 1 - GENERAL

1.1 RELATED DOCUMENTS

- A. Drawings and general provisions of the Contract, including General and Supplementary Conditions and Division 01 Specification Sections, apply to this Section.

1.2 SUMMARY

- A. Section Includes:
 - 1. Penetrations in fire-resistance-rated walls.
 - 2. Penetrations in horizontal assemblies.

1.3 PREINSTALLATION MEETINGS

- A. Preinstallation Conference: Conduct conference at Project site.

1.4 ACTION SUBMITTALS

- A. Product Data: For each type of product proposed. Include product characteristics, typical uses, performance and limitation criteria, test data, and installation instructions.
- B. Shop Drawings: For each through-penetration firestop system, show each kind of construction condition penetrated, relationships to adjoining construction, and kind of penetrating item. Include firestop design designation of testing and inspecting agency acceptable to authorities having jurisdiction that evidences compliance with requirements for each condition required.
- C. Product Schedule: For each penetration firestopping system. Include location, illustration of firestopping system, and design designation of qualified testing and inspecting agency.
 - 1. Engineering Judgments: Where Project conditions require modification to a qualified testing and inspecting agency's illustration for a particular penetration firestopping system, submit illustration, with modifications marked, approved by penetration firestopping system manufacturer's fire-protection engineer as an engineering judgment or equivalent fire-resistance-rated assembly. Obtain approval of authorities having jurisdiction prior to submittal.

1.5 INFORMATIONAL SUBMITTALS

- A. Qualification Data: For Installer.

BURBANK BRANCH RENOVATIONS, PORTLAND PUBLIC LIBRARY

- B. Product Test Reports: For each penetration firestopping system, for tests performed by a qualified testing agency.

1.6 CLOSEOUT SUBMITTALS

- A. Installer Certificates: From Installer indicating that penetration firestopping systems have been installed in compliance with requirements and manufacturer's written instructions.

1.7 QUALITY ASSURANCE

- A. Installer Qualifications: A firm experienced in installing through-penetration firestop systems similar in material, design, and extent to that indicated for this Project, whose work has resulted in construction with a record of successful performance. Qualifications include having the necessary experience, staff, and training to install manufacturer's products per specified requirements. Manufacturer's willingness to sell its through-penetration firestop system products to Contractor or to Installer engaged by Contractor does not in itself confer qualification on buyer.
- B. Preinstallation Conference: Conduct conference at Project site.
- C. Special Inspections: Allow for 1 of each type of firestopping system to be removed and inspected for conformance with approved submittals. All firestopping shall be inspected prior to the installation of ceilings.
- D. Above Ceiling review: Prior to the installation of ceilings, a review of construction completion shall be conducted for firestopping and other items that will not be visible when the ceilings have been installed.

1.8 PROJECT CONDITIONS

- A. Environmental Limitations: Do not install penetration firestopping system when ambient or substrate temperatures are outside limits permitted by penetration firestopping system manufacturers or when substrates are wet because of rain, frost, condensation, or other causes.
- B. Install and cure penetration firestopping materials per manufacturer's written instructions using natural means of ventilations or, where this is inadequate, forced-air circulation.

1.9 COORDINATION

- A. Coordinate construction of openings and penetrating items to ensure that penetration firestopping systems can be installed according to specified firestopping system design.
- B. Coordinate sizing of sleeves, openings, core-drilled holes, or cut openings to accommodate penetration firestopping systems.

PART 2 - PRODUCTS

2.1 PERFORMANCE REQUIREMENTS

A. Fire-Test-Response Characteristics:

1. Perform penetration firestopping system tests by a qualified testing agency acceptable to authorities having jurisdiction.
2. Test per testing standards referenced in "Penetration Firestopping Systems" Article. Provide rated systems complying with the following requirements:
 - a. Penetration firestopping systems shall bear classification marking of a qualified testing agency.
 - 1) UL in its "Fire Resistance Directory."
 - 2) Intertek Group in its "Directory of Listed Building Products."
 - 3) FM Global in its "Building Materials Approval Guide."

2.2 PENETRATION FIRESTOPPING SYSTEMS

A. Penetration Firestopping Systems: Systems that resist spread of fire, passage of smoke and other gases, and maintain original fire-resistance rating of construction penetrated. Penetration firestopping systems shall be compatible with one another, with the substrates forming openings, and with penetrating items if any.

1. Manufacturers: Subject to compliance with requirements, provide products by one of the following:
 - a. 3M Fire Protection Products.
 - b. A/D Fire Protection Systems Inc.
 - c. Hilti, Inc.
 - d. RectorSeal.
 - e. Specified Technologies, Inc.
 - f. Tremco, Inc.

B. Penetrations in Fire-Resistance-Rated Walls: Penetration firestopping systems with ratings determined per ASTM E 814 or UL 1479, based on testing at a positive pressure differential of 0.01-inch wg.

1. F-Rating: Not less than the fire-resistance rating of constructions penetrated.

C. Penetrations in Horizontal Assemblies: Penetration firestopping systems with ratings determined per ASTM E 814 or UL 1479, based on testing at a positive pressure differential of 0.01-inch wg.

1. F-Rating: At least one hour, but not less than the fire-resistance rating of constructions penetrated.
2. T-Rating: At least one hour, but not less than the fire-resistance rating of constructions penetrated except for floor penetrations within the cavity of a wall.

3. W-Rating: Provide penetration firestopping systems showing no evidence of water leakage when tested according to UL 1479.
- D. Exposed Penetration Firestopping Systems: Flame-spread and smoke-developed indexes of less than 25 and 450, respectively, per ASTM E 84.
1. For fire-resistive joint systems exposed to view in public spaces upon completion of Work, provide products that are paintable.
 - a. Mechanical, electrical and elevator machine rooms are not considered public spaces.
- E. Accessories: Provide components for each penetration firestopping system that are needed to install fill materials and to maintain ratings required. Use only those components specified by penetration firestopping system manufacturer and approved by qualified testing and inspecting agency for conditions indicated.
1. Permanent forming/damming/backing materials.
 2. Substrate primers.
 3. Collars.
 4. Steel sleeves.

2.3 FILL MATERIALS

- A. Cast-in-Place Firestop Devices: Factory-assembled devices for use in cast-in-place concrete floors and consisting of an outer sleeve lined with an intumescent strip, a flange attached to one end of the sleeve for fastening to concrete formwork, and a neoprene gasket.
- B. Latex Sealants: Single-component latex formulations that do not re-emulsify after cure during exposure to moisture.
- C. Firestop Devices: Factory-assembled collars formed from galvanized steel and lined with intumescent material sized to fit specific diameter of penetrant.
- D. Intumescent Composite Sheets: Rigid panels consisting of aluminum-foil-faced intumescent elastomeric sheet bonded to galvanized-steel sheet.
- E. Intumescent Putties: Nonhardening, water-resistant, intumescent putties containing no solvents or inorganic fibers.
- F. Intumescent Wrap Strips: Single-component intumescent elastomeric sheets with aluminum foil on one side.
- G. Mortars: Prepackaged dry mixes consisting of a blend of inorganic binders, hydraulic cement, fillers and lightweight aggregate formulated for mixing with water at Project site to form a nonshrinking, homogeneous mortar.
- H. Pillows/Bags: Reusable heat-expanding pillows/bags consisting of glass-fiber cloth cases filled with a combination of mineral-fiber, water-insoluble expansion agents, and fire-retardant

BURBANK BRANCH RENOVATIONS, PORTLAND PUBLIC LIBRARY

additives. Where exposed, cover openings with steel-reinforcing wire mesh to protect pillows/bags from being easily removed.

- I. Silicone Foams: Multicomponent, silicone-based liquid elastomers that, when mixed, expand and cure in place to produce a flexible, nonshrinking foam.
- J. Silicone Sealants: Single-component, silicone-based, neutral-curing elastomeric sealants.

2.4 MIXING

- A. Penetration Firestopping Materials: For those products requiring mixing before application, comply with penetration firestopping system manufacturer's written instructions for accurate proportioning of materials, water (if required), type of mixing equipment, selection of mixer speeds, mixing containers, mixing time, and other items or procedures needed to produce products of uniform quality with optimum performance characteristics for application indicated.

PART 3 - EXECUTION

3.1 EXAMINATION

- A. Examine substrates and conditions, with Installer present, for compliance with requirements for opening configurations, penetrating items, substrates, and other conditions affecting performance of the Work.
- B. Proceed with installation only after unsatisfactory conditions have been corrected.

3.2 PREPARATION

- A. Surface Cleaning: Before installing penetration firestopping systems, clean out openings immediately to comply with manufacturer's written instructions and with the following requirements:
 - 1. Remove from surfaces of opening substrates and from penetrating items foreign materials that could interfere with adhesion of penetration firestopping materials.
 - 2. Clean opening substrates and penetrating items to produce clean, sound surfaces capable of developing optimum bond with penetration firestopping materials. Remove loose particles remaining from cleaning operation.
 - 3. Remove laitance and form-release agents from concrete.
- B. Prime substrates where recommended in writing by manufacturer using that manufacturer's recommended products and methods. Confine primers to areas of bond; do not allow spillage and migration onto exposed surfaces.

3.3 INSTALLATION

- A. General: Install penetration firestopping systems to comply with manufacturer's written installation instructions and published drawings for products and applications.

BURBANK BRANCH RENOVATIONS, PORTLAND PUBLIC LIBRARY

- B. Install forming materials and other accessories of types required to support fill materials during their application and in the position needed to produce cross-sectional shapes and depths required to achieve fire ratings.
 - 1. After installing fill materials and allowing them to fully cure, remove combustible forming materials and other accessories not forming permanent components of firestopping.
- C. Install fill materials by proven techniques to produce the following results:
 - 1. Fill voids and cavities formed by openings, forming materials, accessories and penetrating items to achieve required fire-resistance ratings.
 - 2. Apply materials so they contact and adhere to substrates formed by openings and penetrating items.
 - 3. For fill materials that will remain exposed after completing the Work, finish to produce smooth, uniform surfaces that are flush with adjoining finishes.

3.4 IDENTIFICATION

- A. Wall Identification: Permanently label walls containing penetration firestopping systems with the words "FIRE AND/OR SMOKE BARRIER - PROTECT ALL OPENINGS," using lettering not less than 3 inches high and with minimum 0.375-inch strokes.
 - 1. Locate in accessible concealed floor, floor-ceiling, or attic space at 15 feet from end of wall and at intervals not exceeding 30 feet.
 - 2. Do not install identification on exposed finished wall locations.
- B. Penetration Identification: Identify each penetration firestopping system with legible metal or plastic labels. Attach labels permanently to surfaces adjacent to and within 6 inches of penetration firestopping system edge so labels are visible to anyone seeking to remove penetrating items or firestopping systems. Use mechanical fasteners or self-adhering-type labels with adhesives capable of permanently bonding labels to surfaces on which labels are placed. Include the following information on labels:
 - 1. The words "Warning - Penetration Firestopping - Do Not Disturb. Notify Building Management of Any Damage."
 - 2. Contractor's name, address, and phone number.
 - 3. Designation of applicable testing and inspecting agency.
 - 4. Date of installation.
 - 5. Manufacturer's name.
 - 6. Installer's name.

3.5 FIELD QUALITY CONTROL

- A. Owner will engage a qualified testing agency to perform tests and inspections according to ASTM E 2174.

BURBANK BRANCH RENOVATIONS, PORTLAND PUBLIC LIBRARY

- B. Where deficiencies are found or penetration firestopping system is damaged or removed because of testing, repair or replace penetration firestopping system to comply with requirements.
- C. Proceed with enclosing penetration firestopping systems with other construction only after inspection reports are issued and installations comply with requirements.
- D. Reinstall firestopping materials that have been removed for inspection.

3.6 CLEANING AND PROTECTION

- A. Clean off excess fill materials adjacent to openings as the Work progresses by methods and with cleaning materials that are approved in writing by penetration firestopping system manufacturers and that do not damage materials in which openings occur.
- B. Provide final protection and maintain conditions during and after installation that ensure that penetration firestopping systems are without damage or deterioration at time of Substantial Completion. If, despite such protection, damage or deterioration occurs, immediately cut out and remove damaged or deteriorated penetration firestopping material and install new materials to produce systems complying with specified requirements.

END OF SECTION 078413

SECTION 079200 - JOINT SEALANTS

PART 1 - GENERAL

1.1 RELATED DOCUMENTS

- A. Drawings and general provisions of the Contract, including General and Supplementary Conditions and Division 01 Specification Sections, apply to this Section.

1.2 SUMMARY

- A. Section Includes:
 - 1. Silicone joint sealants.
 - 2. Latex joint sealants.

1.3 ACTION SUBMITTALS

- A. Product Data: For each joint-sealant product indicated.
- B. Samples for Selection: Manufacturer's color charts consisting of strips of cured sealants showing the full range of colors available for each product exposed to view.
- C. Joint-Sealant Schedule: Include the following information:
 - 1. Joint-sealant application, joint location, and designation.
 - 2. Joint-sealant manufacturer and product name.
 - 3. Joint-sealant formulation.
 - 4. Joint-sealant color.

1.4 INFORMATIONAL SUBMITTALS

- A. Product Certificates: For each kind of joint sealant and accessory, from manufacturer.
- B. Product Test Reports: Based on evaluation of comprehensive tests performed by a qualified testing agency, indicating that sealants comply with requirements.
- C. Warranties: Sample of special warranties.

1.5 QUALITY ASSURANCE

- A. Installer Qualifications: An experienced installer who has specialized in installing joint sealants similar in material, design, and extent to those indicated for this Project and whose work has resulted in joint-sealant installations with a record of successful in-service performance.

BURBANK BRANCH RENOVATIONS, PORTLAND PUBLIC LIBRARY

- B. Product Testing: Test joint sealants using a qualified testing agency.
 - 1. Testing Agency Qualifications: An independent testing agency qualified according to ASTM C 1021 to conduct the testing indicated.

1.6 PROJECT CONDITIONS

- A. Do not proceed with installation of joint sealants under the following conditions:
 - 1. When ambient and substrate temperature conditions are outside limits permitted by joint-sealant manufacturer or are below 40 deg F.
 - 2. When joint substrates are wet.
 - 3. Where joint widths are less than those allowed by joint-sealant manufacturer for applications indicated.
 - 4. Where contaminants capable of interfering with adhesion have not yet been removed from joint substrates.

1.7 WARRANTY

- A. Special Installer's Warranty: Manufacturer's standard form in which Installer agrees to repair or replace joint sealants that do not comply with performance and other requirements specified in this Section within specified warranty period.
 - 1. Warranty Period: Two years from date of Substantial Completion.
- B. Manufacturer's Warranty: Manufacturer's standard form in which joint-sealant manufacturer agrees to furnish joint sealants to repair or replace those that do not comply with performance and other requirements specified in this Section within specified warranty period.
 - 1. Warranty Period: Five years from date of Substantial Completion.
- C. Special warranties specified in this article exclude deterioration or failure of joint sealants from the following:
 - 1. Movement of the structure caused by structural settlement or errors attributable to design or construction resulting in stresses on the sealant exceeding sealant manufacturer's written specifications for sealant elongation and compression.
 - 2. Disintegration of joint substrates from natural causes exceeding design specifications.
 - 3. Mechanical damage caused by individuals, tools, or other outside agents.
 - 4. Changes in sealant appearance caused by accumulation of dirt or other atmospheric contaminants.

PART 2 - PRODUCTS

2.1 MATERIALS, GENERAL

- A. Compatibility: Provide joint sealants, backings, and other related materials that are compatible with one another and with joint substrates under conditions of service and application, as demonstrated by joint-sealant manufacturer, based on testing and field experience.
- B. VOC Content of Interior Sealants: Provide sealants and sealant primers for use inside the weatherproofing system that comply with the following limits for VOC content when calculated according to 40 CFR 59, Part 59, Subpart D (EPA Method 24):
 - 1. Architectural Sealants: 250 g/L.
 - 2. Sealant Primers for Nonporous Substrates: 250 g/L.
 - 3. Sealant Primers for Porous Substrates: 775 g/L.
- C. Colors of Exposed Joint Sealants: As selected by Architect from manufacturer's full range.

2.2 SILICONE JOINT SEALANTS

- A. Sealant Type 1: Single-Component, Nonsag, Neutral-Curing Silicone Joint Sealant; ASTM C 920, Type S, Grade NS, Class 100/50, for Use NT.
 - 1. Products: Subject to compliance with requirements, available products that may be incorporated into the Work include, but are not limited to, the following:
 - a. Dow Corning Corporation; 790 (VOC 43); 756 SMS (VOC 87) for cold applications.
 - b. GE Advanced Materials - Silicones; SilPruf LM SCS2700.
 - c. Pecora Corporation; 890 (VOC na).
 - d. Sika Corporation, Construction Products Division; SikaSil-C990.
 - e. Tremco Incorporated; Spectrem 1 (VOC 1).
- B. Sealant Type 2: Not used.
- C. Sealant Type 3: Single-Component, Nonsag, Traffic-Grade, Neutral-Curing Silicone Joint Sealant; ASTM C 920, Type S, Grade NS, Class 100/50, for Use T.
 - 1. Products: Subject to compliance with requirements, available products that may be incorporated into the Work include, but are not limited to, the following:
 - a. Pecora Corporation; 301 NS (VOC 50).
 - b. Tremco Incorporated; Spectrem 800 (VOC 1).
- D. Sealant Type 4: Mildew-Resistant, Single-Component, Acid-Curing Silicone Joint Sealant; ASTM C 920, Type S, Grade NS, Class 25, for Use NT.
 - 1. Products: Subject to compliance with requirements, available products that may be incorporated into the Work include, but are not limited to, the following:

BURBANK BRANCH RENOVATIONS, PORTLAND PUBLIC LIBRARY

- a. Dow Corning Corporation; 786(VOC 33) (Food)
- b. GE Advanced Materials - Silicones; Sanitary SCS1700.
- c. Tremco Incorporated; Tremsil 200 Sanitary (VOC 1).

2.3 LATEX JOINT SEALANTS

- A. Sealant Type 5: Latex Joint Sealant: Acrylic latex or siliconized acrylic latex, ASTM C 834, Type OP, Grade NF.
 1. Products: Subject to compliance with requirements, available products that may be incorporated into the Work include, but are not limited to, the following:
 - a. BASF Building Systems; Sonolac (VOC 41).
 - b. Bostik, Inc.; Chem-Calk 600.
 - c. Pecora Corporation; AC-20 (VOC 31).
 - d. Tremco Incorporated; Tremflex 834.

2.4 JOINT SEALANT BACKING

- A. General: Provide sealant backings of material that are nonstaining; are compatible with joint substrates, sealants, primers, and other joint fillers; and are approved for applications indicated by sealant manufacturer based on field experience and laboratory testing.
- B. Cylindrical Sealant Backings: ASTM C 1330, Type C (closed-cell material with a surface skin), and of size and density to control sealant depth and otherwise contribute to producing optimum sealant performance.
 1. Use Type O (open cell material) at metal-to-metal joints.
- C. Bond-Breaker Tape: Polyethylene tape or other plastic tape recommended by sealant manufacturer for preventing sealant from adhering to rigid, inflexible joint-filler materials or joint surfaces at back of joint. Provide self-adhesive tape where applicable.

2.5 MISCELLANEOUS MATERIALS

- A. Primer: Material recommended by joint-sealant manufacturer where required for adhesion of sealant to joint substrates indicated, as determined from preconstruction joint-sealant-substrate tests and field tests.
- B. Cleaners for Nonporous Surfaces: Chemical cleaners acceptable to manufacturers of sealants and sealant backing materials, free of oily residues or other substances capable of staining or harming joint substrates and adjacent nonporous surfaces in any way, and formulated to promote optimum adhesion of sealants to joint substrates.
- C. Masking Tape: Nonstaining, nonabsorbent material compatible with joint sealants and surfaces adjacent to joints.

PART 3 - EXECUTION

3.1 EXAMINATION

- A. Examine joints indicated to receive joint sealants, with Installer present, for compliance with requirements for joint configuration, installation tolerances, and other conditions affecting joint-sealant performance.
- B. Proceed with installation only after unsatisfactory conditions have been corrected.

3.2 PREPARATION

- A. Surface Cleaning of Joints: Clean out joints immediately before installing joint sealants to comply with joint-sealant manufacturer's written instructions and the following requirements:
 - 1. Remove all foreign material from joint substrates that could interfere with adhesion of joint sealant, including dust, paints (except for permanent, protective coatings tested and approved for sealant adhesion and compatibility by sealant manufacturer), old joint sealants, oil, grease, waterproofing, water repellents, water, surface dirt, and frost.
 - 2. Clean porous joint substrate surfaces by brushing, grinding, mechanical abrading, or a combination of these methods to produce a clean, sound substrate capable of developing optimum bond with joint sealants. Remove loose particles remaining after cleaning operations above by vacuuming or blowing out joints with oil-free compressed air. Porous joint substrates include the following:
 - a. Concrete.
 - b. Masonry.
 - c. Unglazed surfaces of ceramic tile.
 - 3. Remove laitance and form-release agents from concrete.
 - 4. Clean nonporous joint substrate surfaces with chemical cleaners or other means that do not stain, harm substrates, or leave residues capable of interfering with adhesion of joint sealants. Nonporous joint substrates include the following:
 - a. Metal.
 - b. Glass.
 - c. Porcelain enamel.
 - d. Glazed surfaces of ceramic tile.
- B. Joint Priming: Prime joint substrates where recommended by joint-sealant manufacturer or as indicated by preconstruction joint-sealant-substrate tests or prior experience. Apply primer to comply with joint-sealant manufacturer's written instructions. Confine primers to areas of joint-sealant bond; do not allow spillage or migration onto adjoining surfaces.
- C. Masking Tape: Use masking tape where required to prevent contact of sealant or primer with adjoining surfaces that otherwise would be permanently stained or damaged by such contact or by cleaning methods required to remove sealant smears. Remove tape immediately after tooling without disturbing joint seal.

3.3 INSTALLATION OF JOINT SEALANTS

- A. General: Comply with joint-sealant manufacturer's written installation instructions for products and applications indicated, unless more stringent requirements apply.
- B. Sealant Installation Standard: Comply with recommendations in ASTM C 1193 for use of joint sealants as applicable to materials, applications, and conditions indicated.
- C. Install sealant backings of kind indicated to support sealants during application and at position required to produce cross-sectional shapes and depths of installed sealants relative to joint widths that allow optimum sealant movement capability.
 - 1. Do not leave gaps between ends of sealant backings.
 - 2. Do not stretch, twist, puncture, or tear sealant backings.
 - 3. Remove absorbent sealant backings that have become wet before sealant application and replace them with dry materials.
- D. Install bond-breaker tape behind sealants where sealant backings are not used between sealants and backs of joints.
- E. Install sealants using proven techniques that comply with the following and at the same time backings are installed:
 - 1. Place sealants so they directly contact and fully wet joint substrates.
 - 2. Completely fill recesses in each joint configuration.
 - 3. Produce uniform, cross-sectional shapes and depths relative to joint widths that allow optimum sealant movement capability.
- F. Tooling of Nonsag Sealants: Immediately after sealant application and before skinning or curing begins, tool sealants according to requirements specified in subparagraphs below to form smooth, uniform beads of configuration indicated; to eliminate air pockets; and to ensure contact and adhesion of sealant with sides of joint.
 - 1. Remove excess sealant from surfaces adjacent to joints.
 - 2. Use tooling agents that are approved in writing by sealant manufacturer and that do not discolor sealants or adjacent surfaces.
 - 3. Provide concave joint profile per Figure 8A in ASTM C 1193, unless otherwise indicated.
 - a. Use masking tape to protect surfaces adjacent to recessed tooled joints.

3.4 CLEANING

- A. Clean off excess sealant or sealant smears adjacent to joints as the Work progresses by methods and with cleaning materials approved in writing by manufacturers of joint sealants and of products in which joints occur.

BURBANK BRANCH RENOVATIONS, PORTLAND PUBLIC LIBRARY

3.5 PROTECTION

- A. Protect joint sealants during and after curing period from contact with contaminating substances and from damage resulting from construction operations or other causes so sealants are without deterioration or damage at time of Substantial Completion. If, despite such protection, damage or deterioration occurs, cut out and remove damaged or deteriorated joint sealants immediately so installations with repaired areas are indistinguishable from original work.

3.6 JOINT-SEALANT SCHEDULE

- A. Exterior Soft Joints Between Masonry and Metal Door Frames and Windows.
 - 1. Silicone Joint Sealant: Sealant Type 1.
 - 2. Joint-Sealant Color: As selected by Architect from manufacturer's full range of colors.
- B. Under Exterior Door Thresholds.
 - 1. Silicone Joint Sealant: Sealant Type 1.
 - 2. Joint-Sealant Color: As selected by Architect from manufacturer's full range of colors.
- C. Exterior Joints for Which No Other Sealant Type is Indicated.
 - 1. Silicone Joint Sealant: Sealant Type 1.
 - 2. Joint-Sealant Color: As selected by Architect from manufacturer's full range of colors.
- D. Interior Isolation and Contraction Joints in Cast-In-Place Concrete Slabs.
 - 1. Silicone Joint Sealant: Sealant Type 3.
 - 2. Joint-Sealant Color: As selected by Architect from manufacturer's full range of colors.
- E. Concealed Interior Perimeter Joints of Exterior Openings.
 - 1. Silicone Joint Sealant: Sealant Type 1.
 - 2. Joint-Sealant Color: As selected by Architect from manufacturer's full range of colors.
- F. Exposed Interior Perimeter Joints of Exterior Openings.
 - 1. Silicone Joint Sealant: Sealant Type 1.
 - 2. Joint-Sealant Color: As selected by Architect from manufacturer's full range of colors.
- G. Joints between Plumbing Fixtures and Walls and Floors and Between Countertops and Walls.
 - 1. Silicone Joint Sealant: Sealant Type 4.
 - 2. Joint-Sealant Color: As selected by Architect from manufacturer's full range of colors.

BURBANK BRANCH RENOVATIONS, PORTLAND PUBLIC LIBRARY

H. Interior Joints for Which No Other Sealant is Indicated.

1. Latex Joint Sealant: Sealant Type 5.
2. Joint-Sealant Color: As selected by Architect from manufacturer's full range of colors.

END OF SECTION 079200

SECTION 081113 - HOLLOW METAL DOORS AND FRAMES

PART 1 - GENERAL

1.1 RELATED DOCUMENTS

- A. Drawings and general provisions of the Contract, including General and Supplementary Conditions and Division 01 Specification Sections, apply to this Section.

1.2 SUMMARY

- A. Section includes hollow-metal work.
- B. Related Sections:
 - 1. Division 08 Section "Door Hardware" for door hardware for hollow metal doors.
 - 2. Division 09 Sections "Exterior Painting" and "Interior Painting" for field painting hollow metal doors and frames.

1.3 DEFINITIONS

- A. Minimum Thickness: Minimum thickness of base metal without coatings according to SDI A250.8.

1.4 COORDINATION

- A. Coordinate installation of anchorages for hollow metal frames. Furnish setting drawings, templates, and directions for installing anchorages, including sleeves, concrete inserts, anchor bolts, and items with integral anchors. Deliver such items to Project site in time for installation.

1.5 ACTION SUBMITTALS

- A. General: Submittals for Sections 081113, 081416 and 087100 shall be made concurrently.
- B. Product Data: For each type of product indicated. Include construction details, material descriptions, core descriptions, fire-resistance rating, and finishes.
- C. Shop Drawings: Include the following:
 - 1. Elevations of each door design.
 - 2. Details of doors, including vertical and horizontal edge details and metal thicknesses.
 - 3. Frame details for each frame type, including dimensioned profiles and metal thicknesses.
 - 4. Locations of reinforcement and preparations for hardware.
 - 5. Details of each different wall opening condition.
 - 6. Details of anchorages, joints, field splices, and connections.

BURBANK BRANCH RENOVATIONS, PORTLAND PUBLIC LIBRARY

7. Details of accessories.
8. Details of moldings, removable stops, and glazing.

- D. Schedule: Provide a schedule of hollow-metal work prepared by or under the supervision of supplier, using same reference numbers for details and openings as those on Drawings. Coordinate with final Door Hardware Schedule.

1.6 INFORMATIONAL SUBMITTALS

- A. Product Test Reports: Based on evaluation of comprehensive tests performed by a qualified testing agency, for each type of hollow metal door and frame assembly.

1.7 DELIVERY, STORAGE, AND HANDLING

- A. Deliver hollow metal work palletized, wrapped, or crated to provide protection during transit and Project-site storage. Do not use nonvented plastic.
- B. Deliver welded frames with two removable spreader bars across bottom of frames, tack welded to jambs and mullions.
- C. Store hollow metal work under cover at Project site. Place in stacks of five units maximum in a vertical position with heads up, spaced by blocking, on minimum 4-inch- high wood blocking. Do not store in a manner that traps excess humidity.
 1. Provide minimum 1/4-inch space between each stacked door to permit air circulation.

1.8 PROJECT CONDITIONS

- A. Field Measurements: Verify actual dimensions of openings by field measurements before fabrication.

PART 2 - PRODUCTS

2.1 MANUFACTURERS

- A. Manufacturers: Subject to compliance with requirements, provide products by one of the following:
 1. Standard Steel Doors and Frames:
 - a. Ceco Door Products; an Assa Abloy Group company.
 - b. Curries Company.
 - c. J/R Metal Frames Manufacturing, Inc.
 - d. Steelcraft; a division of Ingersoll-Rand.
- B. Source Limitations: Obtain hollow metal work from single source from single manufacturer.

2.2 REGULATORY REQUIREMENTS

- A. Fire-Rated Assemblies: Complying with NFPA 80 and listed and labeled by a qualified testing agency acceptable to authorities having jurisdiction for fire-protection ratings[**and temperature-rise limits**] indicated, based on testing at positive pressure according to NFPA 252 or UL 10C.
 - 1. Smoke- and Draft-Control Assemblies: Provide an assembly with gaskets listed and labeled for smoke and draft control by a qualified testing agency acceptable to authorities having jurisdiction, based on testing according to UL 1784 and installed in compliance with NFPA 105.
- B. Fire-Rated, Borrowed-Light Assemblies: Complying with NFPA 80 and listed and labeled by a testing and inspecting agency acceptable to authorities having jurisdiction for fire-protection ratings indicated, based on testing according to NFPA 257 or UL 9.
- C. Comply with the Americans with Disabilities Act (ADA) and with code provisions as adopted by authorities having jurisdiction.
 - 1. Doors: Provide doors as required by accessibility regulations and requirements of authorities having jurisdiction. These include, but are not limited to, the following:
 - a. Clear Width: 32 inches with door 90 degrees open.
 - b. Maneuvering Clearances: Refer to Code for various side and approach clearances.
 - c. Double-Leaf Doorways: Provide at least one leaf that meets the clear width and maneuvering clearances.
 - d. Two Doors in Series: Provide a distance of four feet plus the width of any door swinging into the space between hinged or pivoted doors.
 - 2. Notify Architect of details or specifications not conforming to code.

2.3 INTERIOR DOORS AND FRAMES

- A. Construct interior doors and frames to comply with the standards indicated for materials, fabrication, hardware locations, hardware reinforcement, tolerances, and clearances, and as specified.
- B. Heavy-Duty Doors and Frames: SDI A250.8, Level 2.
 - 1. Physical Performance: Level B according to SDI A250.4.
 - 2. Doors:
 - a. Type: As indicated in the Door and Frame Schedule.
 - b. Thickness: 1-3/4 inches.
 - c. Face: Uncoated, cold-rolled steel sheet, minimum thickness of 0.042 inch.
 - d. Edge Construction: Model 2, Seamless.
 - a. Core: Kraft-paper honeycomb.
 - 3. Frames:

BURBANK BRANCH RENOVATIONS, PORTLAND PUBLIC LIBRARY

- a. Materials: Uncoated steel sheet, minimum thickness of 0.053 inch.
 - b. Construction: Face welded.
4. Exposed Finish: Factory primed.

2.4 EXTERIOR HOLLOW-METAL DOORS AND FRAMES

- A. Construct exterior doors and frames to comply with the standards indicated for materials, fabrication, hardware locations, hardware reinforcement, tolerances, and clearances, and as specified.
- B. Heavy-Duty Doors and Frames: SDI A250.8, Level 2.
1. Physical Performance: Level B according to SDI A250.4.
 2. Doors:
 - a. Type: As indicated in the Door and Frame Schedule.
 - b. Thickness: 1-3/4 inches
 - c. Face: Metallic-coated steel sheet, minimum thickness of 0.042 inch, with minimum A60 coating.
 - d. Edge Construction: Model 2, Seamless.
 - e. Core: Manufacturer's standard kraft-paper honeycomb, polystyrene, polyurethane, polyisocyanurate, mineral-board, or vertical steel-stiffener core at manufacturer's discretion.
 - 1) Thermal-Rated (Insulated) Doors: Where indicated, provide doors fabricated with thermal-resistance value (R-value) of not less than 10.0 deg F x h x sq. ft./Btu when tested according to ASTM C 1363.
 3. Frames:
 - a. Materials: Metallic-coated steel sheet, minimum thickness of 0.053 inch, with minimum A60 coating.
 - b. Construction: Face welded.
 4. Exposed Finish: Factory primed.

2.5 BORROWED LITES

- A. Hollow-metal frames of uncoated steel sheet, minimum thickness of 0.053 inch.
- B. Construction: Face welded.

2.6 FRAME ANCHORS

- A. Jamb Anchors:
1. Stud-Wall Type: Designed to engage stud, welded to back of frames; not less than 0.042 inch thick.

BURBANK BRANCH RENOVATIONS, PORTLAND PUBLIC LIBRARY

- B. Floor Anchors: Formed from same material as frames, not less than 0.042 inch thick, and as follows:
 - 1. Monolithic Concrete Slabs or Wood Flooring: Clip-type anchors, with two holes to receive fasteners.

2.7 MATERIALS

- A. Cold-Rolled Steel Sheet: ASTM A 1008/A 1008M, Commercial Steel (CS), Type B; suitable for exposed applications.
- B. Hot-Rolled Steel Sheet: ASTM A 1011/A 1011M, Commercial Steel (CS), Type B; free of scale, pitting, or surface defects; pickled and oiled.
- C. Metallic-Coated Steel Sheet: ASTM A 653/A 653M, Commercial Steel (CS), Type B; with minimum A60 metallic coating.
 - 1. Wipe Coat Galvanneal materials will not be considered acceptable.
- D. Frame Anchors: ASTM A 591/A 591M, Commercial Steel (CS), 40Z coating designation; mill phosphatized.
 - 1. For anchors built into exterior walls, steel sheet complying with ASTM A 1008/A 1008M or ASTM A 1011/A 1011M, hot-dip galvanized according to ASTM A 153/A 153M, Class B.
- E. Inserts, Bolts, and Fasteners: Hot-dip galvanized according to ASTM A 153/A 153M.
- F. Powder-Actuated Fasteners in Concrete: Fastener system of type suitable for application indicated, fabricated from corrosion-resistant materials, with clips or other accessory devices for attaching hollow metal frames of type indicated.
- G. Mineral-Fiber Insulation: ASTM C 665, Type I (blankets without membrane facing); consisting of fibers manufactured from slag or rock wool with 6- to 12-lb/cu. ft. density; with maximum flame-spread and smoke-development indexes of 25 and 50, respectively; passing ASTM E 136 for combustion characteristics.
- H. Glazing: Comply with requirements in Division 08 Section "Glazing."
- I. Bituminous Coating: Cold-applied asphalt mastic, SSPC-Paint 12, compounded for 15-mil dry film thickness per coat. Provide inert-type noncorrosive compound free of asbestos fibers, sulfur components, and other deleterious impurities.

2.8 FABRICATION

- A. Fabricate hollow metal work to be rigid and free of defects, warp, or buckle. Accurately form metal to required sizes and profiles, with minimum radius for thickness of metal. Where practical, fit and assemble units in manufacturer's plant. To ensure proper assembly at Project site, clearly identify work that cannot be permanently factory assembled before shipment.

B. Hollow Metal Doors:

1. Fire Door Cores: As required to provide fire-protection[**and temperature-rise**] ratings indicated.
2. Vertical Edges for Single-Acting Doors: Bevel edges 1/8 inch in 2 inches.
3. Top Edge Closures: Close top edges of doors with inverted closures, except provide flush closures at exterior doors of same material as face sheets.
4. Bottom Edge Closures: Close bottom edges of doors with end closures or channels of same material as face sheets.
5. Exterior Doors: Provide weep-hole openings in bottoms of exterior doors to permit moisture to escape. Seal joints in top edges of doors against water penetration.
6. Full hinge cut-outs for non-handed doors will not be acceptable.

C. Hollow Metal Frames: Where frames are fabricated in sections due to shipping or handling limitations, provide alignment plates or angles at each joint, fabricated of same thickness metal as frames.

1. Sidelight Frames: Provide closed tubular members with no visible face seams or joints, fabricated from same material as door frame. Fasten members at crossings and to jambs by butt welding.
2. Provide countersunk, flat- or oval-head exposed screws and bolts for exposed fasteners unless otherwise indicated.
3. Grout Guards: Weld guards to frame at back of hardware mortises in frames to be grouted.
4. Floor Anchors: Weld anchors to bottom of jambs and mullions with at least four spot welds per anchor.
5. Jamb Anchors: Provide number and spacing of anchors as follows:
 - a. Stud-Wall Type: Locate anchors not more than 18 inches from top and bottom of frame. Space anchors not more than 32 inches o.c. and as follows:
 - 1) Three anchors per jamb up to 60 inches high.
 - 2) Four anchors per jamb from 60 to 90 inches high.
 - 3) Five anchors per jamb from 90 to 96 inches high.
 - 4) Five anchors per jamb plus 1 additional anchor per jamb for each 24 inches or fraction thereof above 96 inches high.
 - 5) Two anchors per head for frames above 42 inches wide and mounted in metal-stud partitions.
6. Head Anchors: Two anchors per head for frames more than 42 inches wide and mounted in metal-stud partitions.
7. Door Silencers: Except on weather-stripped doors, drill stops to receive door silencers as follows. Keep holes clear during construction.
 - a. Single-Door Frames: Drill stop in strike jamb to receive three door silencers.

D. Fabricate concealed stiffeners, edge channels, and hardware reinforcement from either cold- or hot-rolled steel sheet.

BURBANK BRANCH RENOVATIONS, PORTLAND PUBLIC LIBRARY

- E. Hardware Preparation: Factory prepare hollow-metal work to receive templated mortised hardware; include cutouts, reinforcement, mortising, drilling, and tapping according to SDI A250.6, the Door Hardware Schedule, and templates.
 - 1. Reinforce doors and frames to receive nontemplated, mortised, and surface-mounted door hardware.
 - 2. Comply with applicable requirements in SDI A250.6 and BHMA A156.115 for preparation of hollow-metal work for hardware.
- F. Stops and Moldings: Provide stops and moldings around glazed lites and louvers where indicated. Form corners of stops and moldings with butted or mitered hairline joints.
 - 1. Single Glazed Lites: Provide fixed stops and moldings welded on secure side of hollow-metal work.
 - 2. Provide fixed frame moldings on outside of exterior and on secure side of interior doors and frames.
 - 3. Provide loose stops and moldings on inside of hollow-metal work.
 - 4. Coordinate rabbet width between fixed and removable stops with glazing and installation types indicated.
 - 5. Where indicated, provide molding kits for existing hollow metal doors.

2.9 ACCESSORIES

- A. Mullions and Transom Bars: Join to adjacent members by welding or rigid mechanical anchors.
- B. Grout Guards: Formed from same material as frames, not less than 0.016 inch thick.

2.10 STEEL FINISHES

- A. Prime Finish: Clean, pretreat, and apply manufacturer's standard primer.
 - 1. Shop Primer: Manufacturer's standard, fast-curing, lead- and chromate-free primer complying with SDI A250.10; recommended by primer manufacturer for substrate; compatible with substrate and field-applied coatings despite prolonged exposure.

PART 3 - EXECUTION

3.1 EXAMINATION

- A. Examine substrates, areas, and conditions, with Installer present, for compliance with requirements for installation tolerances and other conditions affecting performance of the Work.
- B. Examine roughing-in for embedded and built-in anchors to verify actual locations before frame installation.
- C. Proceed with installation only after unsatisfactory conditions have been corrected.

3.2 PREPARATION

- A. Remove welded-in shipping spreaders installed at factory. Restore exposed finish by grinding, filling, and dressing, as required to make repaired area smooth, flush, and invisible on exposed faces.
- B. Drill and tap doors and frames to receive nontemplated, mortised, and surface-mounted door hardware.

3.3 INSTALLATION

- A. General: Install hollow metal work plumb, rigid, properly aligned, and securely fastened in place; comply with Drawings and manufacturer's written instructions.
- B. Hollow Metal Frames: Install hollow metal frames of size and profile indicated. Comply with ANSI/SDI A250.11.
 - 1. Set frames accurately in position, plumbed, aligned, and braced securely until permanent anchors are set. After wall construction is complete, remove temporary braces, leaving surfaces smooth and undamaged.
 - a. At fire-protection-rated openings, install frames according to NFPA 80.
 - b. Where frames are fabricated in sections because of shipping or handling limitations, field splice at approved locations by welding face joint continuously; grind, fill, dress, and make splice smooth, flush, and invisible on exposed faces.
 - c. Install frames with removable glazing stops located on secure side of opening.
 - d. Install door silencers in frames before grouting.
 - e. Remove temporary braces necessary for installation only after frames have been properly set and secured.
 - f. Check plumbness, squareness, and twist of frames as walls are constructed. Shim as necessary to comply with installation tolerances.
 - g. Field apply bituminous coating to backs of frames that will be filled with grout containing antifreezing agents.
 - 2. Floor Anchors: Provide floor anchors for each jamb and mullion that extends to floor, and secure with postinstalled expansion anchors.
 - a. Floor anchors may be set with powder-actuated fasteners instead of postinstalled expansion anchors if so indicated and approved on Shop Drawings.
 - 3. Wood-Stud Partitions: Solidly pack mineral-fiber insulation inside frames.
 - 4. Installation Tolerances: Adjust hollow metal door frames for squareness, alignment, twist, and plumb to the following tolerances:
 - a. Squareness: Plus or minus 1/16 inch, measured at door rabbet on a line 90 degrees from jamb perpendicular to frame head.
 - b. Alignment: Plus or minus 1/16 inch, measured at jambs on a horizontal line parallel to plane of wall.
 - c. Twist: Plus or minus 1/16 inch, measured at opposite face corners of jambs on parallel lines, and perpendicular to plane of wall.

BURBANK BRANCH RENOVATIONS, PORTLAND PUBLIC LIBRARY

- d. Plumbness: Plus or minus 1/16 inch, measured at jambs at floor.
- C. Hollow Metal Doors: Fit hollow metal doors accurately in frames, within clearances specified below. Shim as necessary.
 - 1. Non-Fire-Rated Standard Steel Doors:
 - a. Between Door and Frame Jambs and Head: 1/8 inch plus or minus 1/32 inch.
 - b. Between Edges of Pairs of Doors: 1/8 inch to 1/4 inch plus or minus 1/32 inch.
 - c. At Bottom of Door: 3/4 inch plus or minus 1/32 inch.
 - d. Between Door Face and Stop: 1/16 inch to 1/8 inch plus or minus 1/32 inch.
 - 2. Fire-Rated Doors: Install doors with clearances according to NFPA 80.
 - 3. Smoke-Control Doors: Install doors according to NFPA 105.
- D. Glazing: Comply with installation requirements in Division 08 Section "Glazing" and with hollow metal manufacturer's written instructions.
 - 1. Secure stops with countersunk flat- or oval-head machine screws spaced uniformly not more than 9 inches o.c. and not more than 2 inches o.c. from each corner.

3.4 ADJUSTING AND CLEANING

- A. Final Adjustments: Check and readjust operating hardware items immediately before final inspection. Leave work in complete and proper operating condition. Remove and replace defective work, including hollow metal work that is warped, bowed, or otherwise unacceptable.
- B. Remove grout and other bonding material from hollow metal work immediately after installation.
- C. Prime-Coat Touchup: Immediately after erection, sand smooth rusted or damaged areas of prime coat and apply touchup of compatible air-drying, rust-inhibitive primer.
- D. Metallic-Coated Surfaces: Clean abraded areas and repair with galvanizing repair paint according to manufacturer's written instructions.

END OF SECTION 081113

SECTION 081416 - FLUSH WOOD DOORS

PART 1 - GENERAL

1.1 RELATED DOCUMENTS

- A. Drawings and general provisions of the Contract, including General and Supplementary Conditions and Division 01 Specification Sections, apply to this Section.

1.2 SUMMARY

A. Section Includes:

1. Solid-core doors with wood-veneer faces.
2. Factory finishing flush wood doors.
3. Factory fitting flush wood doors to frames and factory machining for hardware.
4. Factory glazing of wood doors.

B. Related Sections:

1. Division 08 Section "Glazing" for glass view panels in flush wood doors.

1.3 PREINSTALLATION MEETINGS

- A. Preinstallation Conference: Conduct conference at Project site.

1.4 ACTION SUBMITTALS

- A. General: Submittals for Sections 081113, 081416 and 087100 shall be made concurrently.
- B. Product Data: For each type of door indicated. Include details of core and edge construction, and trim for openings. Include factory-finishing specifications.
- C. Shop Drawings: Indicate location, size, and hand of each door; elevation of each kind of door; construction details not covered in Product Data; location and extent of hardware blocking; and other pertinent data.
 1. Dimensions and locations of blocking.
 2. Dimensions and locations of mortises and holes for hardware.
 3. Dimensions and locations of cutouts.
 4. Undercuts.
 5. Doors to be factory finished and finish requirements.
 6. Fire-protection ratings for fire-rated doors.
- D. Samples for Verification:

BURBANK BRANCH RENOVATIONS, PORTLAND PUBLIC LIBRARY

1. Factory finishes applied to actual door face materials, approximately 8 by 10 inches, for each material and finish.

1.5 INFORMATIONAL SUBMITTALS

- A. Warranty: Sample of warranty.

1.6 DELIVERY, STORAGE, AND HANDLING

- A. Comply with requirements of referenced standard and manufacturer's written instructions.
- B. Package doors individually in plastic bags or cardboard cartons.
- C. Mark each door on bottom rail with opening number used on Shop Drawings.

1.7 FIELD CONDITIONS

- A. Environmental Limitations: Do not deliver or install doors until spaces are enclosed and weathertight, wet work in spaces is complete and dry, and HVAC system is operating and maintaining ambient temperature and humidity conditions at occupancy levels during the remainder of the construction period.

1.8 WARRANTY

- A. Warranty: Manufacturer's standard form in which manufacturer agrees to repair or replace doors that fail in materials or workmanship within specified warranty period.
 1. Failures include, but are not limited to, the following:
 - a. Warping (bow, cup, or twist) more than 1/4 inch in a 42-by-84-inch section.
 - b. Telegraphing of core construction in face veneers exceeding 0.01 inch in a 3-inch span.
 2. Warranty shall also include installation and finishing that may be required due to repair or replacement of defective doors.
 3. Warranty Period for Solid-Core Interior Doors: Life of installation.

PART 2 - PRODUCTS

2.1 MANUFACTURERS

- A. Manufacturers: Subject to compliance with requirements, provide products by one of the following:
 1. Flush Wood Doors:

BURBANK BRANCH RENOVATIONS, PORTLAND PUBLIC LIBRARY

- a. Algoma Hardwoods Inc.
- b. Eggers Industries.
- c. Graham Wood Doors; an Assa Abloy Group company.
- d. Marshfield Door Systems, Inc..
- e. VT Industries Inc.

B. Source Limitations: Obtain flush wood doors from single manufacturer.

2.2 FLUSH WOOD DOORS, GENERAL

A. Quality Standard: In addition to requirements specified, comply with WDMA I.S.1-A, "Architectural Wood Flush Doors."

1. Contract Documents contain selections chosen from options in quality standard and additional requirements beyond those of quality standard. Comply with those selections and requirements in addition to quality standard.

B. WDMA I.S.1-A Performance Grade: Extra Heavy Duty.

C. Fire-Rated Wood Doors: Doors complying with NFPA 80 that are listed and labeled by a qualified testing agency, for fire-protection ratings indicated, based on testing at positive pressure according to NFPA 252 and UL 10C.

1. Include all requirements as part of the door construction per Category "A" guidelines."
2. [Temperature-Rise Limit: [Where indicated] [At vertical exit enclosures and exit passageways], provide doors that have a maximum transmitted temperature end point of not more than 450 deg F above ambient after 30 minutes of standard fire-test exposure.]
3. Cores: Provide core specified or mineral core as needed to provide fire-protection rating indicated.
4. Edge Construction: Provide edge construction with intumescent seals concealed by outer stile. Comply with specified requirements for exposed edges.

D. Smoke- and Draft-Control Door Assemblies: Listed and labeled for smoke and draft control, based on testing according to UL 1784.

E. Particleboard-Core Doors:

1. Particleboard: ANSI A208.1, Grade LD-2.
2. Blocking: Provide wood blocking in particleboard-core doors as needed to eliminate through-bolting hardware.

F. Structural-Composite-Lumber-Core Doors:

1. Structural Composite Lumber: WDMA I.S.10.
 - a. Screw Withdrawal, Face: 700 lbf.
 - b. Screw Withdrawal, Edge: 400 lbf.
2. Provide doors with structural-composite-lumber cores instead of particleboard cores for the following doors:

BURBANK BRANCH RENOVATIONS, PORTLAND PUBLIC LIBRARY

- a. Doors indicated to receive exit devices.
- b. Doors where oversized glass lites exceed more than 40 percent of the door surface area.
- c. Doors where louvers exceed more than 40 percent of the door surface area.

G. Mineral-Core Doors:

1. Core: Noncombustible mineral product complying with requirements of referenced quality standard and testing and inspecting agency for fire-protection rating indicated.
2. Blocking: Provide composite blocking with improved screw-holding capability approved for use in doors of fire-protection ratings indicated as needed to eliminate through-bolting hardware.
3. Edge Construction: At hinge stiles, provide laminated-edge construction with improved screw-holding capability and split resistance. Comply with specified requirements for exposed edges.
 - a. Screw-Holding Capability: 550 lbf per WDMA T.M.-10.

2.3 VENEERED-FACED DOORS FOR TRANSPARENT FINISH

A. Interior Solid-Core Doors:

1. Grade: Premium, with Grade A faces.
2. Species: White oak.
3. Cut: Plain sliced (flat sliced).
4. Match between Veneer Leaves: Slip match.
5. Assembly of Veneer Leaves on Door Faces: Running match.
6. Exposed Vertical Edges: Same species as faces - edge Type A.
7. Core: Particleboard except where structural composite lumber is required.
8. Construction: Five plies. Stiles and rails are bonded to core, then entire unit abrasive planed before veneering.

2.4 LIGHT FRAMES

A. Wood Beads for Light Openings in Wood Doors: Provide manufacturer's standard wood beads as follows unless otherwise indicated.

1. Wood Species: Same species as door faces.
2. Profile: Flush rectangular beads.

2.5 FABRICATION

A. Factory fit doors to suit frame-opening sizes indicated. Comply with clearance requirements of referenced quality standard for fitting unless otherwise indicated.

1. Comply with requirements in NFPA 80 for fire-rated doors.

- B. Factory machine doors for hardware that is not surface applied. Locate hardware to comply with DHI-WDHS-3. Comply with final hardware schedules, door frame Shop Drawings, DHI A115-W series standards, and hardware templates.
 - 1. Coordinate with hardware mortises in metal frames to verify dimensions and alignment before factory machining.
- C. Openings: Cut and trim openings through doors in factory.
 - 1. Light Openings: Trim openings with moldings of material and profile indicated. Attach wood rectangular glazing beads flush with door face. Apply shims and sealant as required to set glazing.
 - 2. Glazing: Factory install glazing in doors indicated to be factory finished. Comply with applicable requirements in Section 088000 "Glazing."

2.6 FACTORY FINISHING

- A. General: Comply with referenced quality standard for factory finishing. Complete fabrication, including fitting doors for openings and machining for hardware that is not surface applied, before finishing.
 - 1. Finish faces, all four edges, edges of cutouts, and mortises. Stains and fillers may be omitted on bottom edges, edges of cutouts, and mortises.
- B. Finish doors at factory.
- C. Transparent Finish:
 - 1. Grade: Premium.
 - 2. Finish: WDMA TR-4 conversion varnish or TR-6 catalyzed polyurethane.
 - 3. Staining: None required.
 - 4. Effect: Open-grain finish.
 - 5. Sheen: Satin.

PART 3 - EXECUTION

3.1 EXAMINATION

- A. Examine doors and installed door frames before hanging doors.
 - 1. Verify that frames comply with indicated requirements for type, size, location, and swing characteristics and have been installed with level heads and plumb jambs.
 - 2. Reject doors with defects.
- B. Proceed with installation only after unsatisfactory conditions have been corrected.

3.2 INSTALLATION

- A. Hardware: For installation, see Division 08 Section "Door Hardware."
- B. Installation Instructions: Install doors to comply with manufacturer's written instructions and the referenced quality standard, and as indicated.
 - 1. Install fire-rated doors in corresponding fire-rated frames according to NFPA 80.
 - 2. Install smoke- and draft-control doors according to NFPA 105.
- C. Factory-Fitted Doors: Align in frames for uniform clearance at each edge.
- D. Factory-Finished Doors: Restore finish before installation if fitting or machining is required at Project site.

3.3 ADJUSTING

- A. Operation: Rehang or replace doors that do not swing or operate freely.
- B. Finished Doors: Replace doors that are damaged or that do not comply with requirements. Doors may be repaired or refinished if work complies with requirements and shows no evidence of repair or refinishing.

END OF SECTION 081416

SECTION 085200 - WOOD WINDOWS

PART 1 - GENERAL

1.1 RELATED DOCUMENTS

- A. Drawings and general provisions of the Contract, including General and Supplementary Conditions and Division 01 Specification Sections, apply to this Section.

1.2 SUMMARY

- A. Section includes the following:
 - 1. New replacement window sashes and jamb liners.

1.3 PREINSTALLATION MEETINGS

- A. Preinstallation Conference: Conduct conference at Project site.
 - 1. Review and finalize construction schedule and verify availability of materials, Installer's personnel, equipment, and facilities needed to make progress and avoid delays.
 - 2. Review, discuss, and coordinate the interrelationship of wood windows with other exterior wall components. Include provisions for anchoring, flashing, weeping, sealing perimeters, and protecting finishes.
 - 3. Review and discuss the sequence of work required to construct a watertight and weathertight exterior building envelope.
 - 4. Inspect and discuss the condition of substrate and other preparatory work performed by other trades.

1.4 ACTION SUBMITTALS

- A. Product Data: For each type of product.
 - 1. Include construction details, material descriptions, glazing and fabrication methods, dimensions of individual components and profiles, hardware, and finishes for wood windows.
- B. Shop Drawings: Include plans, elevations, sections, hardware, accessories, insect screens, operational clearances, and details of installation, including anchor, flashing, and sealant installation.
- C. Samples: For each exposed product and for each color specified, 2 by 4 inches in size.
- D. Samples for Selection: For units with factory-applied color finishes.
 - 1. Include similar Samples of hardware and accessories involving color selection.

BURBANK BRANCH RENOVATIONS, PORTLAND PUBLIC LIBRARY

- E. Product Schedule: For wood windows. Use same designations indicated on Drawings.

1.5 INFORMATIONAL SUBMITTALS

- A. Qualification Data: For manufacturer and Installer.
- B. Product Test Reports: For each type of wood window, for tests performed by a qualified testing agency.
 - 1. Large Multiple Window Unit Applications: Provide integral structural metal reinforcement approved by licensed Engineer.
- C. Field quality-control reports.
- D. Sample Warranties: For manufacturer's warranties.

1.6 MATERIALS MAINTENANCE SUBMITTALS

- A. Furnish extra materials that match products installed and that are packaged with protective covering for storage and identified with labels describing contents.
 - 1. Window Screens: Furnish six (4) replacement screens.

1.7 QUALITY ASSURANCE

- A. Manufacturer Qualifications: A manufacturer capable of fabricating wood windows that meet or exceed performance requirements indicated and of documenting this performance by test reports, and calculations.
- B. Manufacturer Source Limitations: Obtain wood windows through one source from a single manufacturer.
- C. Product Options: Drawings indicate size, profiles, and dimensional requirements of wood windows and are based on the specific system indicated. Refer to Division 01 Section "Product Requirements." Do not modify size and dimensional requirements.
 - 1. Do not modify intended aesthetic effects, as judged solely by Architect, except with Architect's approval. If modifications are proposed, submit comprehensive explanatory data to Architect for review.
- D. Sample Installation: Before installing window units, install a mulled window sample window to demonstrate installation procedure. Install to comply with the following requirements, using materials indicated for the completed Work:
 - 1. Coordinate the presence of Architect, Owner, window manufacturer representative, and air barrier manufacturer representative.
 - 2. Review, discuss, and coordinate the interrelationship of windows with other exterior wall components. Include provisions for structural anchorage, glazing, flashing, weeping, sealants, and protection of finishes.

BURBANK BRANCH RENOVATIONS, PORTLAND PUBLIC LIBRARY

3. Review process for sealing joints in top, sides and bottom of mulled units.
 4. Review and discuss the sequence of work required to construct a watertight and weathertight exterior building envelope.
 5. Inspect and discuss the condition of substrate and other preparatory work performed by other trades.
 6. Approval of sample is for relationship of window with air barrier installation; and aesthetic qualities of workmanship.
 7. Approved sample may become part of the completed Work if undisturbed at time of Substantial Completion.
- E. Preinstallation Conference: Conduct conference at Project site to comply with requirements in Division 01 Section "Project Management and Coordination." Review methods and procedures related to wood windows including, but not limited to, the following:
1. Review and finalize construction schedule and verify availability of materials, Installer's personnel, equipment, and facilities needed to make progress and avoid delays.
 2. Review sample installation, discuss, and coordinate the interrelationship of wood windows with other exterior wall components. Include provisions for structural anchorage, glazing, flashing, weeping, sealants, and protection of finishes.
 3. Review and discuss the sequence of work required to construct a watertight and weathertight exterior building envelope.
 4. Inspect and discuss the condition of substrate and other preparatory work performed by other trades.

1.8 PROJECT CONDITIONS

- A. Field Measurements: Verify wood window openings by field measurements before fabrication and indicate measurements on Shop Drawings.
1. Established Dimensions: Where field measurements cannot be made without delaying the Work, establish opening dimensions and proceed with fabricating wood windows without field measurements. Coordinate wall construction to ensure that actual opening dimensions correspond to established dimensions.

1.9 WARRANTY

- A. Special Warranty: Manufacturer's standard form in which manufacturer agrees to repair or replace wood windows that fail in materials or workmanship within specified warranty period.
1. Failures include, but are not limited to, the following:
 - a. Failure to meet performance requirements.
 - b. Structural failures including excessive deflection, water leakage, air infiltration, or condensation.
 - c. Faulty operation of movable sash and hardware.
 - d. Deterioration of wood, metals, vinyl, other materials, and finishes beyond normal weathering.
 - e. Failure of insulating glass.

BURBANK BRANCH RENOVATIONS, PORTLAND PUBLIC LIBRARY

2. Warranty Period:
 - a. Window: Ten years from date of Substantial Completion.
 - b. Glazing: 20 years from date of Substantial Completion.
 - c. Aluminum-Cladding Finish: 20 years from date of Substantial Completion.

PART 2 - PRODUCTS

2.1 MANUFACTURERS

- A. Available Manufacturers: Subject to compliance with requirements, manufacturers offering products that may be incorporated into the Work include, but are not limited to, the following:
 1. Aluminum-Clad Wood Replacement Windows:
 - a. Marvin Windows and Doors;
 - 1) Tilt Pac Double Hung Sash Replacement System.
 - 2) Replacement Casement.
 - b. Other manufacturer offering replacement window products meeting the requirements of this section.

2.2 WOOD WINDOWS

- A. Operating Types: Provide the following operating types in locations indicated on Drawings:
 1. Double hung.
 2. Custom fixed.
- B. Frames and Sashes: Fine-grained wood lumber complying with AAMA/WDMA/CSA 101/I.S.2/A440; kiln dried to a moisture content of not more than 12 percent at time of fabrication; free of visible finger joints, blue stain, knots, pitch pockets, and surface checks larger than 1/32 inch deep by 2 inches wide; water-repellent preservative treated.
 1. Exterior Finish: Aluminum-clad wood.
 - a. Aluminum Finish: Manufacturer's standard fluoropolymer two-coat system with fluoropolymer color topcoat containing not less than 70 percent polyvinylidene fluoride resin by weight and complying with AAMA 2605.
 - b. Color: As selected by Architect from manufacturer's full range.
 2. Interior Finish: Manufacturer's standard factory-prime coat.
 - a. Color: White.
- C. Glass: Clear, insulating-glass units, with low-E coating pyrolytic on second surface or sputtered on second or third surface with argon gas.

BURBANK BRANCH RENOVATIONS, PORTLAND PUBLIC LIBRARY

- D. Hardware, General: Provide manufacturer's standard hardware fabricated from aluminum, stainless steel, carbon steel complying with AAMA 907, or other corrosion-resistant material compatible with adjacent materials; designed to smoothly operate, tightly close, and securely lock windows, and sized to accommodate sash weight and dimensions.
 - 1. Exposed Hardware Color and Finish: As selected by Architect from manufacturer's full range.
- E. Hung Window Hardware:
 - 1. Counterbalancing Mechanism: Complying with AAMA 902, concealed, of size and capacity to hold sash stationary at any open position.
 - 2. Locks and Latches: Allow unobstructed movement of the sash across adjacent sash in direction indicated and operated from the inside only.
 - 3. Tilt Hardware: Releasing tilt latch allows sash to pivot about horizontal axis to facilitate cleaning exterior surfaces from the interior.
 - 4. Handles: Applied sash lift on bottom rail of forward placed operating sash; one per sash.
- F. Weather Stripping: Provide full-perimeter weather stripping for each operable sash unless otherwise indicated.
- G. Fasteners: Noncorrosive and compatible with window members, trim, hardware, anchors, and other components.
 - 1. Exposed Fasteners: Do not use exposed fasteners to the greatest extent possible. For application of hardware, use fasteners that match finish hardware being fastened.

2.3 ACCESSORIES

- A. Simulated Divided Lites: 7/8 inches wide with internal spacer, extruded aluminum exterior bar and wood interior bar. Bars adhered to glass with double coated foam tape.

2.4 INSECT SCREENS

- A. General: Design windows and hardware to accommodate screens in a tight-fitting, removable arrangement, with a minimum of exposed fasteners and latches. Fabricate insect screens to fully integrate with window frame. Locate screens on inside of casement windows and outside of double-hung windows and provide for each operable exterior sash or ventilator.
- B. Aluminum Insect Screen Frames: Manufacturer's standard aluminum alloy complying with SMA 1004. Fabricate frames with mitered or coped joints or corner extrusions, concealed fasteners, and removable PVC spline/anchor concealing edge of frame.
 - 1. Aluminum Tubular Framing Sections and Cross Braces: Roll formed from aluminum sheet with minimum wall thickness as required for class indicated.
 - 2. Finish: Manufacturer's standard finish in color to match window.

BURBANK BRANCH RENOVATIONS, PORTLAND PUBLIC LIBRARY

- C. Glass-Fiber Mesh Fabric: 18-by-14 or 18-by-16 mesh of PVC-coated, glass-fiber threads; woven and fused to form a fabric mesh resistant to corrosion, shrinkage, stretch, impact damage, and weather deterioration; in the following color. Comply with ASTM D 3656.

- 1. Mesh Color: Charcoal gray.

2.5 FABRICATION

- A. Fabricate wood windows in sizes indicated. Include a complete system for assembling components and anchoring windows.
- B. Glaze wood windows in the factory.
- C. Weather strip each operable sash to provide weathertight installation.
- D. Factory Mullions: Provide mullions and cover plates, matching window units, complete with anchors for support to structure and installation of window units. Allow for erection tolerances and provide for movement of window units due to thermal expansion and building deflections, as indicated. Provide mullions and cover plates capable of withstanding design loads of window units. Where factory mullions are not available, provide .060" break metal flashing or cladding matching finish of windows.
 - 1. Seal joints between mullioned units and provide a full-width vinyl flashing cap at the head of the mullioned unit to prevent air and water infiltration.
- E. Complete fabrication, assembly, finishing, hardware application, and other work in the factory to greatest extent possible. Disassemble components only as necessary for shipment and installation. Allow for scribing, trimming, and fitting at Project site.

PART 3 - EXECUTION

3.1 EXAMINATION

- A. Examine openings, substrates, structural support, anchorage, and conditions, with Installer present, for compliance with requirements for installation tolerances and other conditions affecting performance of work. Verify rough opening dimensions, levelness of sill plate, and operational clearances. Examine wall flashings, vapor retarders, water and weather barriers, and other built-in components to ensure a coordinated, weathertight window installation.
 - 1. Proceed with installation only after unsatisfactory conditions have been corrected.

3.2 PREPARATION

- A. Install membrane strip flashing in accordance with manufacturer's recommendations and details on the drawings.

3.3 INSTALLATION

- A. Comply with Drawings, Shop Drawings, and manufacturer's written instructions for installing windows, hardware, accessories, and other components.
- B. Install windows level, plumb, square, true to line, without distortion or impeding thermal movement, anchored securely in place to structural support, and in proper relation to wall flashing and other adjacent construction.

3.4 ADJUSTING, CLEANING, AND PROTECTION

- A. Adjust operating sashes and hardware for a tight fit at contact points and weather stripping for smooth operation and weathertight closure.
- B. Clean exposed surfaces immediately after installing windows. Remove excess sealants, glazing materials, dirt, and other substances.
 - 1. Keep protective films and coverings in place until final cleaning.
- C. Remove and replace sashes if glass has been broken, chipped, cracked, abraded, or damaged during construction period.
- D. Protect window surfaces from contact with contaminating substances resulting from construction operations. If contaminating substances do contact window surfaces, remove contaminants immediately according to manufacturer's written instructions.

END OF SECTION 085200

SECTION 087100 - DOOR HARDWARE

PART 1 - GENERAL

1.1 RELATED DOCUMENTS

- A. Drawings and general provisions of the Contract, including General and Supplementary Conditions and Division 01 Specification Sections, apply to this Section.

1.2 SUMMARY

- A. This Section includes the following:
 - 1. Commercial door hardware for the following:
 - a. Swinging doors.
- B. Related Sections include the following:
 - 1. Division 08 Section "Hollow Metal Doors and Frames" for door silencers provided as part of hollow-metal frames.
 - 2. Division 08 Section "Flush Wood Doors" for integral intumescent seals provided as part of fire-rated labeled assemblies.

1.3 ACTION SUBMITTALS

- A. General: Submittals for Sections 081113, 081416 and 087100 shall be made concurrently.
- B. Product Data: Include construction and installation details, material descriptions, dimensions of individual components and profiles, and finishes.
- C. Samples for Verification: Submit minimum 2-by-4-inch plate Samples of each type of finish required, except primed finish.
- D. Other Action Submittals:
 - 1. Door Hardware Sets: Prepared by or under the supervision of Architectural Hardware Consultant, detailing fabrication and assembly of door hardware, as well as procedures and diagrams. Coordinate the final door hardware sets with doors, frames, and related work to ensure proper size, thickness, hand, function, and finish of door hardware.
 - a. Format: Comply with scheduling sequence and vertical format in DHI's "Sequence and Format for the Hardware Schedule." Double space entries, and number and date each page.
 - b. Format: Use same scheduling sequence and format and use same door numbers as in the Contract Documents.
 - c. Content: Include the following information:

BURBANK BRANCH RENOVATIONS, PORTLAND PUBLIC LIBRARY

- 1) Identification number, location, hand, fire rating, and material of each door and frame.
 - 2) Type, style, function, size, quantity, and finish of each door hardware item. Include description and function of each lockset and exit device.
 - 3) Complete designations of every item required for each door or opening including name and manufacturer.
 - 4) Fastenings and other pertinent information.
 - 5) Location of each door hardware set, cross-referenced to Drawings, both on floor plans and in door and frame schedule.
 - 6) Explanation of abbreviations, symbols, and codes contained in schedule.
 - 7) Mounting locations for door hardware.
 - 8) Door and frame sizes and materials.
 - 9) List of related door devices specified in other Sections for each door and frame.
- d. Submittal Sequence: Submit initial draft of final schedule along with essential Product Data to facilitate the fabrication of other work that is critical in Project construction schedule. Submit the final door hardware sets after Samples, Product Data, coordination with Shop Drawings of other work, delivery schedules, and similar information has been completed and accepted.
2. Keying Schedule: Prepared by or under the supervision of Architectural Hardware Consultant, detailing Owner's final keying instructions for locks. Include schematic keying diagram and index each key set to unique door designations.

1.4 INFORMATIONAL SUBMITTALS

- A. Product Certificates: For electrified door hardware, signed by product manufacturer.
1. Certify that door hardware approved for use on types and sizes of labeled fire doors complies with listed fire door assemblies.
- B. Product Test Reports: For compliance with accessibility requirements, based on evaluation of comprehensive tests performed by manufacturer and witnessed by a qualified testing agency, for door hardware on doors located in accessible routes.
- C. Warranty: Special warranty specified in this Section.

1.5 CLOSEOUT SUBMITTALS

- A. Maintenance Data: For each type of door hardware to include in maintenance manuals. Include final hardware and keying schedule.

1.6 QUALITY ASSURANCE

- A. Installer Qualifications: An experienced installer who has completed door hardware similar in material, design, and extent to that indicated for this Project and whose work has resulted in construction with a record of successful in-service performance.

BURBANK BRANCH RENOVATIONS, PORTLAND PUBLIC LIBRARY

- B. Architectural Hardware Consultant Qualifications: A person who is experienced in providing consulting services for door hardware installations that are comparable in material, design, and extent to that indicated for this Project and who is currently certified by DHI as follows:
 - 1. For door hardware, an Architectural Hardware Consultant (AHC)
- C. Source Limitations: Obtain each type and variety of door hardware from a single manufacturer, unless otherwise indicated.
 - 1. Provide electrified door hardware from same manufacturer as mechanical door hardware, unless otherwise indicated. Manufacturers that perform electrical modifications and that are listed by a testing and inspecting agency acceptable to authorities having jurisdiction are acceptable.
- D. Fire-Rated Door Assemblies: Where fire-rated door assemblies are indicated, provide door hardware rated for use in assemblies complying with NFPA 80 that are listed and labeled by a qualified testing agency, for fire-protection ratings indicated, based on testing at positive pressure according to NFPA 252 or UL 10C, unless otherwise indicated.
- E. Smoke- and Draft-Control Door Assemblies: Where smoke- and draft-control door assemblies are required, provide door hardware that meet requirements of assemblies tested according to UL 1784 and installed in compliance with NFPA 105.
 - 1. Air Leakage Rate: Maximum air leakage of 0.3 cfm/sq. ft. at the tested pressure differential of 0.3-inch wg of water.
- F. Accessibility Requirements: Comply with applicable provisions in the DOJ's 2010 ADA Standards for Accessible Design for door hardware on doors in an accessible route.
 - 1. Provide operating devices that do not require tight grasping, pinching, or twisting of the wrist and that operate with a force of not more than 5 lbf.
 - 2. Comply with the following maximum opening-force requirements:
 - a. Interior, Non-Fire-Rated Hinged Doors: 5 lbf applied perpendicular to door.
 - b. Fire Doors: Minimum opening force allowable by authorities having jurisdiction.
 - 3. Bevel raised thresholds with a slope of not more than 1:2. Provide thresholds not more than 1/2 inch high.
 - 4. Closers: Adjust door and gate closer sweep periods so that, from an open position of 90 degrees, the time required to move the door to a position of 12 degrees from the latch is 5 seconds minimum.
 - 5. Spring Hinges: Adjust door and gate spring hinges so that, from an open position of 70 degrees, the time required to move the door to the closed position is 1.5 seconds minimum.
- G. Keying Conference: Conduct conference at Project site to comply with requirements in Division 01 Section "Project Management and Coordination." In addition to Owner Contractor, and Architect, conference participants shall also include Installer's Architectural Hardware Consultant. Incorporate keying conference decisions into final keying schedule after reviewing door hardware keying system including, but not limited to, the following:

BURBANK BRANCH RENOVATIONS, PORTLAND PUBLIC LIBRARY

1. Function of building, flow of traffic, purpose of each area, degree of security required, and plans for future expansion.
2. Preliminary key system schematic diagram.
3. Requirements for key control system.
4. Address for delivery of keys.

H. Preinstallation Conference: Conduct conference at Project site to comply with requirements in Division 01 Section "Project Management and Coordination." Review methods and procedures related to electrified door hardware including, but not limited to, the following:

1. Inspect and discuss electrical roughing-in and other preparatory work performed by other trades.
2. Review sequence of operation for each type of electrified door hardware.
3. Review and finalize construction schedule and verify availability of materials, Installer's personnel, equipment, and facilities needed to make progress and avoid delays.
4. Review required testing, inspecting, and certifying procedures.

1.7 DELIVERY, STORAGE, AND HANDLING

- A. Inventory door hardware on receipt and provide secure lock-up for door hardware delivered to Project site.
- B. Tag each item or package separately with identification related to the final door hardware sets, and include basic installation instructions, templates, and necessary fasteners with each item or package.
- C. Deliver keys to Owner by registered mail or overnight package service.

1.8 COORDINATION

- A. Coordinate layout and installation of floor-recessed door hardware with floor construction. Cast anchoring inserts into concrete.
- B. Installation Templates: Distribute for doors, frames, and other work specified to be factory prepared. Check Shop Drawings of other work to confirm that adequate provisions are made for locating and installing door hardware to comply with indicated requirements.
- C. Security: Coordinate installation of door hardware, keying, and access control with Owner's security consultant.
- D. Existing Openings: Where new hardware components are scheduled for application to existing construction or where modifications to existing door hardware are required, field verify existing conditions and coordinate installation of door hardware to suit opening conditions and to provide for proper operation.

1.9 WARRANTY

- A. Special Warranty: Manufacturer's standard form in which manufacturer agrees to repair or replace components of door hardware that fail in materials or workmanship within specified warranty period.
 - 1. Failures include, but are not limited to, the following:
 - a. Structural failures including excessive deflection, cracking, or breakage.
 - b. Faulty operation of operators and door hardware.
 - c. Deterioration of metals, metal finishes, and other materials beyond normal weathering and use.
 - 2. Warranty Period: One year from date of Substantial Completion, except as follows:
 - a. Exit Devices: Two years from date of Substantial Completion.
 - b. Manual Closers: 10 years from date of Substantial Completion.

PART 2 - PRODUCTS

2.1 SCHEDULED DOOR HARDWARE

- A. General: Provide door hardware for each door to comply with requirements in this Section and door hardware sets indicated in Part 3 "Door Hardware Sets" Article.
 - 1. Door Hardware Sets: Provide quantity, item, size, finish or color indicated, and named manufacturers' products.
- B. Designations: Requirements for design, grade, function, finish, size, and other distinctive qualities of each type of door hardware are indicated in Part 3 "Door Hardware Sets" Article. Products are identified by using door hardware designations, as follows:
 - 1. Named Manufacturers' Products: Manufacturer and product designation are listed for each door hardware type required for the purpose of establishing minimum requirements.
- C. In other Part 2 articles where titles below introduce lists, the following requirements apply to product selection:
 - 1. Manufacturers: Subject to compliance with requirements, provide products by the manufacturers specified.

2.2 HINGES, GENERAL

- A. Quantity: Provide the following, unless otherwise indicated:
 - 1. Two Hinges: For doors with heights up to 60 inches.
 - 2. Three Hinges: For doors with heights 61 to 90 inches.
 - 3. Four Hinges: For doors with heights 91 to 120 inches.

BURBANK BRANCH RENOVATIONS, PORTLAND PUBLIC LIBRARY

- 4. For doors with heights more than 120 inches, provide 4 hinges, plus 1 hinge for every 30 inches of door height greater than 120 inches.
- B. Template Requirements: Except for hinges and pivots to be installed entirely (both leaves) into wood doors and frames, provide only template-produced units.
- C. Hinge Weight: Unless otherwise indicated, provide the following:
 - 1. Entrance Doors: Heavy-weight hinges.
 - 2. Doors with Closers: Antifriction-bearing hinges.
 - 3. Interior Doors: Antifriction-bearing hinges.
- D. Hinge Base Metal: Unless otherwise indicated, provide the following:
 - 1. Exterior Hinges: Stainless steel, with stainless-steel pin.
 - 2. Interior Hinges: Steel, with steel pin.
 - 3. Hinges for Fire-Rated Assemblies: Steel, with steel pin.
- E. Hinge Options: Where indicated in door hardware sets or on Drawings:
 - 1. Nonremovable Pins: Provide set screw in hinge barrel that, when tightened into a groove in hinge pin, prevents removal of pin while door is closed; for outswinging exterior doors and outswinging corridor doors with locks.
 - 2. Corners: Square.
- F. Fasteners: Comply with the following:
 - 1. Machine Screws: For metal doors and frames. Install into drilled and tapped holes.
 - 2. Wood Screws: For wood doors and frames.
 - 3. Threaded-to-the-Head Wood Screws: For fire-rated wood doors.
 - 4. Screws: Phillips flat-head; machine screws (drilled and tapped holes) for metal doors and wood screws for wood doors and frames. Finish screw heads to match surface of hinges.

2.3 HINGES

- A. Butts and Hinges: BHMA A156.1.
- B. Template Hinge Dimensions: BHMA A156.7.
- C. Available Manufacturers:
 - 1. Hager Companies (HAG).
 - 2. McKinney Products Company; an ASSA ABLOY Group company (MCK).
 - 3. Stanley Commercial Hardware; Div. of The Stanley Works (STH).
- D. The following is a guide for hinge size and type required for this project.

	Manufacturer	Interior:	Exterior
1-3/4" Doors	Stanley	FBB179-4 1/2"	FBB191-4 1/2"
up to 3'-0" wide	Hager	BB1279-4 1/2"	BB1191-4 1/2"

McKinney

TA-TB2714-4 1/2"

TA-TB2314-4 1/2"

2.4 SPRING HINGES

- A. Self-Closing Hinges: BHMA A156.17.
- B. Spring Hinges: Provide No. 1001 6 x 4-1/2 Simplex Full Mortise Double-Acting Spring Butt Hinge by McKinney, Bommer 3029-6, or approved substitute.

2.5 LOCKS AND LATCHES, GENERAL

- A. Accessibility Requirements: Where indicated to comply with accessibility requirements, comply with the U.S. Architectural & Transportation Barriers Compliance Board's "Americans with Disabilities Act (ADA), Accessibility Guidelines for Buildings and Facilities (ADAAG)."
 - 1. Provide operating devices that do not require tight grasping, pinching, or twisting of the wrist and that operate with a force of not more than 5 lbf.
- B. Latches and Locks for Means of Egress Doors: Comply with NFPA 101. Latches shall not require more than 15 lbf to release the latch. Locks shall not require use of a key, tool, or special knowledge for operation.
- C. Lock Trim:
 - 1. Levers: Cast.
 - 2. Escutcheons (Roses): Forged.
 - 3. Operating Device: Lever with escutcheons (roses).
- D. Lock Throw: Comply with testing requirements for length of bolts required for labeled fire doors, and as follows:
 - 1. Bored Locks: Minimum 1/2-inch latchbolt throw.
 - 2. Mortise Locks: Minimum 3/4-inch latchbolt throw.
- E. Backset: 2-3/4 inches, unless otherwise indicated.
- F. Strikes: Manufacturer's standard strike with strike box for each latchbolt or lock bolt, with curved lip extended to protect frame, finished to match door hardware set, and as follows:
 - 1. Strikes for Bored Locks and Latches: BHMA A156.2.
 - 2. Strikes for Mortise Locks and Latches: BHMA A156.13.
 - 3. Flat-Lip Strikes: For locks with three-piece antifriction latchbolts, as recommended by manufacturer.
 - 4. Extra-Long-Lip Strikes: For locks used on frames with applied wood casing trim.

2.6 MORTISED LOCKS AND LATCHES

- A. Manufacturers: Subject to compliance with requirements, provide products by one of the following:

BURBANK BRANCH RENOVATIONS, PORTLAND PUBLIC LIBRARY

- 1. Mechanical Locks and Latches:
 - a. Best Lock Corporation (BLC).
 - b. Corbin Russwin Architectural Hardware; Div. of Yale Security Inc. (CR).
 - c. Sargent Manufacturing Company; an Assa Abloy Group company (SGT).
 - d. Schlage Lock Company; an Ingersoll-Rand Company (SCH).

- B. Mortise Locks: Stamped steel case with steel or brass parts; BHMA Grade 1; Series 1000.

- 1. Provide one of the following manufacturers and designs:
 - a. Best 40H Series
 - b. Corbin/Russwin ML2000 Series
 - c. Sargent 8200 Series
 - d. Schlage L9000 Series

C. Lock Trim: Comply with the following:

- 1. Lockset Designs: Provide the lockset design designated below or, if sets are provided by another manufacturer, provide designs that match those designated:
 - a. Best, 14 design
 - b. Corbin/Russwin, Newport design
 - c. Sargent, LNL design
 - d. Schlage, 06A design

D. Lock Functions: Lock functions as indicated in the hardware schedule shall be as follows:

FUNCTION	SARGENT	SCHLAGE	CORBIN/RUSSWIN	BEST
E (entrance)	16	60	42	F

2.7 BORED LOCKS AND LATCHES

A. Manufacturers: Subject to compliance with requirements, provide products by one of the following:

- 1. Mechanical Locks and Latches:
 - a. Best Lock Corporation (BLC).
 - b. Corbin Russwin Architectural Hardware; Div. of Yale Security Inc. (CR).
 - c. Sargent Manufacturing Company; an Assa Abloy Group company (SGT).
 - d. Schlage Lock Company; an Ingersoll-Rand Company (SCH).

B. Bored Locks: BHMA Grade 1; Series 4000.

- 1. Provide one of the following manufacturers and designs:
 - a. Best: 9K Series
 - b. Corbin Russwin: CL3300 Series.
 - c. Sargent: 10 Line

BURBANK BRANCH RENOVATIONS, PORTLAND PUBLIC LIBRARY

- d. Schlage: ND Series
- C. Auxiliary Locks: BHMA Grade 1.
- D. Lock Trim: Comply with the following:
 - 1. Lockset Designs: Provide the lockset design designated below or, if sets are provided by another manufacturer, provide designs that match those designated:
 - a. Best: 15 C
 - b. Corbin Russwin: NZD
 - c. Sargent: LL
 - d. Schlage: Rhodes
- E. Lock Functions: Lock functions as indicated in the hardware schedule shall be as follows:

FUNCTION	SARGENT	SCHLAGE	CORBIN/RUSWIN	BEST
(1) (utility)	04	80	57	D
(2) (office)	05	53	51	AB
(3) (passage)	15	10	10	N
(4) (classroom)	37	70	55	R
(5) (entrance)	16	60	72	C
(6) (privacy)	65	40	20	L

2.8 LOCK CYLINDERS

- A. Standard Lock Cylinders: BHMA A156.5, Grade 1.
- B. Cylinders: Manufacturer's standard tumbler type, constructed from brass or bronze, stainless steel, or nickel silver, and complying with the following:
 - 1. Number of Pins: Six.
 - 2. Mortise Type: Threaded cylinders with rings and straight- or clover-type cam.
 - 3. Rim Type: Cylinders with back plate, flat-type vertical or horizontal tailpiece, and raised trim ring.
 - 4. Bored-Lock Type: Cylinders with tailpieces to suit locks.
 - a. High-Security Grade: BHMA A156.5, Grade 1A, listed and labeled as complying with pick- and drill-resistant testing requirements in UL 437 (Suffix A).
- C. Construction Keying: Comply with the following:
 - 1. Construction Master Keys: Provide cylinders with feature that permits voiding of construction keys without cylinder removal. Provide 10 construction master keys.
- D. Manufacturers: Subject to compliance with requirements, provide products by one of the following:
 - 1. Cylinders: Same manufacturer as for locks and latches.

BURBANK BRANCH RENOVATIONS, PORTLAND PUBLIC LIBRARY

2.9 KEYING

- A. Keying System: Factory registered, complying with guidelines in BHMA A156.28, Appendix A. Incorporate decisions made in keying conference, and as follows:
 - 1. Existing System: Master key or grand master key locks to Owner's existing system.
 - 2. Keyed Alike: Key all cylinders to same change key.
- B. Keys: Nickel silver.
 - 1. Stamping: Permanently inscribe each key with a visual key control number and include the following notation:
 - a. Notation: Information to be furnished by Owner.
 - 2. Quantity: In addition to one extra key blank for each lock, provide the following:
 - a. Cylinder Change Keys: Three.
 - b. Master Keys: Five.

2.10 CLOSERS

- A. Surface Closers: BHMA A156.4; rack-and-pinion hydraulic type with adjustable sweep and latch speeds controlled by key-operated valves and forged-steel main arm. Comply with manufacturer's written recommendations for size of door closers depending on size of door, exposure to weather, and anticipated frequency of use. Provide factory-sized closers, adjustable to meet field conditions and requirements for opening force.
- B. Manufacturers: Subject to compliance with requirements, provide products by one of the following:
 - 1. Surface-Mounted Closers:
 - a. LCN Closers; an Ingersoll-Rand Company (LCN).
 - b. SARGENT Manufacturing Company; an ASSA ABLOY Group company.
- C. Accessibility Requirements: Where handles, pulls, latches, locks, and other operating devices are indicated to comply with accessibility requirements, comply with the U.S. Architectural & Transportation Barriers Compliance Board's "Americans with Disabilities Act (ADA), Accessibility Guidelines for Buildings and Facilities (ADAAG)."
 - 1. Comply with the following maximum opening-force requirements:
 - a. Interior, Non-Fire-Rated Hinged Doors: 5 lbf applied perpendicular to door.
 - b. Fire Doors: Minimum opening force allowable by authorities having jurisdiction.
- D. Door Closers for Means of Egress Doors: Comply with NFPA 101. Door closers shall not require more than 30 lbf to set door in motion and not more than 15 lbf to open door to minimum required width.

BURBANK BRANCH RENOVATIONS, PORTLAND PUBLIC LIBRARY

- E. Size of Units: Unless otherwise indicated, comply with manufacturer's written recommendations for size of door closers depending on size of door, exposure to weather, and anticipated frequency of use. Provide factory-sized closers, adjustable to meet field conditions and requirements for opening force.
 - 1. LCN:
 - a. Exterior: 4040 Series
 - b. Interior: 4040 Series
 - 2. Sargent:
 - a. Exterior: 281
 - b. Interior: 281
- F. Coordinators: BHMA A156.3.

2.11 PROTECTIVE TRIM UNITS

- A. Size: 1-1/2 inches less than door width on push side and 1/2 inch less than door width on pull side, by height specified in door hardware sets.
- B. Fasteners: Manufacturer's standard machine or self-tapping screws.
- C. Metal Protective Trim Units: BHMA A156.6; beveled top and 2 sides; fabricated from the following material:
 - 1. Material: 0.050-inch- thick stainless steel.
 - 2. Available Manufacturers:
 - a. Burns Manufacturing Incorporated (BM).
 - b. Don-Jo Mfg., Inc. (DJO).
 - c. Hager Companies (HAG).
 - d. IVES Hardware; an Ingersoll-Rand Company (IVS).
 - e. Rockwood Manufacturing Company (RM).
- D. Fabricate protection plates as follows:
 - 1. Push Plates: 16" high by 8" wide.
 - 2. Kick Plates: 10" high by 1-1/2" less than door width for single doors and 1" less than door width for pairs of doors. Kick plates shall be applied to push side of all doors where noted.

2.12 STOPS AND HOLDERS

- A. Stops and Bumpers: BHMA A156.16, Grade 1.
 - 1. Provide wall stops for doors unless floor or other type stops are scheduled or indicated. Do not mount floor stops where they will impede traffic. Where floor or wall stops are not appropriate, provide overhead holders.

2. Provide matching finishes for hardware units at each door or opening, to the greatest extent possible, and except as otherwise indicated. Reduce differences in color and textures as much as commercially possible where the base metal or metal forming process is different for individual units of hardware exposed at the same door or opening. In general, match items to the manufacturer's standard finish for the latch and lock set (or push-pull units if no latch-lock sets) for color and texture.

B. Wall Stops: Wall type bumpers with concealed type flange shall be used where ever possible.

1. Available Products:

- a. Ives - 407 1/2
- b. Door Controls - 3211T
- c. Rockwood - 409

C. Floor Stops: Where wall type bumpers cannot be used, provide dome type, floor mounted stops of the proper height as follows:

1. Available Products:

- a. Ives - 436, 438
- b. Door Controls - 3310X, 3320X
- c. Rockwood - 440, 442

D. Exterior doors striking masonry and doors specified to have door stops and holders, shall have cast bronze wall or floor type door stops with hook or staple type holders to selectively hold doors in open position. The following will be acceptable:

1. Available Products:

- a. Ives - 445, 446
- b. Door Controls - 3237X, 3347X
- c. Rockwood - 473, 477

E. Silencers for Metal Door Frames: BHMA A156.16, Grade 1; neoprene or rubber, minimum diameter 1/2 inch; fabricated for drilled-in application to frame.

2.13 DOOR GASKETING

A. Door Gasketing: BHMA A156.22; air leakage not to exceed 0.50 cfm per foot of crack length for gasketing other than for smoke control, as tested according to ASTM E 283; with resilient or flexible seal strips that are easily replaceable and readily available from stocks maintained by manufacturer.

B. Weatherstripping:

1. Perimeter Gasketing: Apply to head and jamb, forming seal between door and frame. Basis-of-Design Product, No. A626A by National Guard Products or approved substitute.
2. Meeting Stile Gasketing: Fasten to meeting stiles, forming seal when doors are closed. Basis-of-Design Product, No. 600A by National Guard Products or approved substitute.

3. Door Bottoms: Apply to bottom of door, forming seal with threshold when door is closed. Basis-of-Design Product, No. 95WH by National Guard Products or approved substitute.

- C. Smoke-Labeled Gasketing: Assemblies complying with NFPA 105 that are listed and labeled by a testing and inspecting agency acceptable to authorities having jurisdiction, for smoke-control ratings indicated, based on testing according to UL 1784.

1. Provide smoke-labeled gasketing on fire-rated doors and on smoke-labeled doors. Basis-of-Design Product, No. 5050 by National Guard Products or approved substitute.

2.14 THRESHOLDS

- A. Standard: BHMA A156.21.

- B. Accessibility Requirements: Where thresholds are indicated to comply with accessibility requirements, comply with the U.S. Architectural & Transportation Barriers Compliance Board's "Americans with Disabilities Act (ADA), Accessibility Guidelines for Buildings and Facilities (ADAAG)."

1. Bevel raised thresholds with a slope of not more than 1:2. Provide thresholds not more than 1/2 inch high.

- C. Thresholds for Means of Egress Doors: Comply with NFPA 101. Maximum 1/2 inch high.

- D. Manufacturers:

1. Provide No. 896 with door bottom sweep No. 95WH by National Guard Products or approved substitute.

2.15 FABRICATION

- A. Manufacturer's Nameplate: Do not provide products that have manufacturer's name or trade name displayed in a visible location except in conjunction with required fire-rated labels and as otherwise approved by Architect.

1. Manufacturer's identification is permitted on rim of lock cylinders only.

- B. Base Metals: Produce door hardware units of base metal, fabricated by forming method indicated, using manufacturer's standard metal alloy, composition, temper, and hardness. Furnish metals of a quality equal to or greater than that of specified door hardware units and BHMA A156.18. Do not furnish manufacturer's standard materials or forming methods if different from specified standard.

- C. Fasteners: Provide door hardware manufactured to comply with published templates generally prepared for machine, wood, and sheet metal screws. Provide screws according to commercially recognized industry standards for application intended, except aluminum fasteners are not permitted. Provide Phillips flat-head screws with finished heads to match surface of door hardware, unless otherwise indicated.

BURBANK BRANCH RENOVATIONS, PORTLAND PUBLIC LIBRARY

1. Concealed Fasteners: For door hardware units that are exposed when door is closed, except for units already specified with concealed fasteners. Do not use through bolts for installation where bolt head or nut on opposite face is exposed unless it is the only means of securely attaching the door hardware. Where through bolts are used on hollow door and frame construction, provide sleeves for each through bolt.
2. Steel Machine or Wood Screws: For the following fire-rated applications:
 - a. Mortise hinges to doors.
 - b. Strike plates to frames.
 - c. Closers to doors and frames.
3. Steel Through Bolts: For the following fire-rated applications unless door blocking is provided:
 - a. Surface hinges to doors.
 - b. Closers to doors and frames.
 - c. Surface-mounted exit devices.
4. Spacers or Sex Bolts: For through bolting of hollow-metal doors.
5. Fasteners for Wood Doors: Comply with requirements in DHI WDHS.2, "Recommended Fasteners for Wood Doors."

2.16 FINISHES

- A. Standard: BHMA A156.18, as indicated in door hardware sets.
- B. Protect mechanical finishes on exposed surfaces from damage by applying a strippable, temporary protective covering before shipping.
- C. Appearance of Finished Work: Variations in appearance of abutting or adjacent pieces are acceptable if they are within one-half of the range of approved Samples. Noticeable variations in the same piece are not acceptable. Variations in appearance of other components are acceptable if they are within the range of approved Samples and are assembled or installed to minimize contrast.
- D. Provide the following finishes:
 1. Butts and Hinges: 26D
 2. Locks & Lock Trim: 26D
 3. Door Controls - Closers: Sprayed Alum. Finish
 4. Mortise Locks & Latches: 26D
 5. Door Stops 26D/32D
 6. Weatherstripping Aluminum
 7. Threshold Aluminum
 8. Kickplates 32D

PART 3 - EXECUTION

3.1 EXAMINATION

- A. Examine doors and frames, with Installer present, for compliance with requirements for installation tolerances, labeled fire door assembly construction, wall and floor construction, and other conditions affecting performance.
- B. Proceed with installation only after unsatisfactory conditions have been corrected.

3.2 PREPARATION

- A. Steel Doors and Frames: Comply with DHI A115 Series.
 - 1. Surface-Applied Door Hardware: Drill and tap doors and frames according to ANSI A250.6.
- B. Wood Doors: Comply with DHI A115-W Series.

3.3 INSTALLATION

- A. Mounting Heights: Mount door hardware units at heights indicated as follows unless otherwise indicated or required to comply with governing regulations.
 - 1. Standard Steel Doors and Frames: DHI's "Recommended Locations for Architectural Hardware for Standard Steel Doors and Frames."
 - 2. Wood Doors: DHI WDHS.3, "Recommended Locations for Architectural Hardware for Wood Flush Doors."
- B. Install each door hardware item to comply with manufacturer's written instructions. Where cutting and fitting are required to install door hardware onto or into surfaces that are later to be painted or finished in another way, coordinate removal, storage, and reinstallation of surface protective trim units with finishing work specified in Division 09 Sections. Do not install surface-mounted items until finishes have been completed on substrates involved.
 - 1. Set units level, plumb, and true to line and location. Adjust and reinforce attachment substrates as necessary for proper installation and operation.
 - 2. Drill and countersink units that are not factory prepared for anchorage fasteners. Space fasteners and anchors according to industry standards.
- C. Thresholds: Set thresholds for exterior and acoustical doors in full bed of sealant complying with requirements specified in Division 07 Section "Joint Sealants."

3.4 ADJUSTING

- A. Initial Adjustment: Adjust and check each operating item of door hardware and each door to ensure proper operation or function of every unit. Replace units that cannot be adjusted to

BURBANK BRANCH RENOVATIONS, PORTLAND PUBLIC LIBRARY

operate as intended. Adjust door control devices to compensate for final operation of heating and ventilating equipment and to comply with referenced accessibility requirements.

1. Spring Hinges: Adjust to achieve positive latching when door is allowed to close freely from an open position of 30 degrees.
2. Door Closers: Unless otherwise required by authorities having jurisdiction, adjust sweep period so that, from an open position of 70 degrees, the door will take at least 3 seconds to move to a point 3 inches from the latch, measured to the leading edge of the door.

- B. Occupancy Adjustment: Approximately six months after date of Substantial Completion, Installer shall examine and readjust, including adjusting operating forces, each item of door hardware as necessary to ensure function of doors, door hardware, and electrified door hardware.

3.5 CLEANING AND PROTECTION

- A. Clean adjacent surfaces soiled by door hardware installation.
- B. Clean operating items as necessary to restore proper function and finish.
- C. Provide final protection and maintain conditions that ensure that door hardware is without damage or deterioration at time of Substantial Completion.

3.6 DEMONSTRATION

- A. Engage a factory-authorized service representative to train Owner's maintenance personnel to adjust, operate, and maintain door hardware and door hardware finishes. Refer to Division 01 Section "Demonstration and Training."

3.7 DOOR HARDWARE SETS

- A. The hardware sets listed below indicate the items of hardware required for each opening. It is the bidder's responsibility to accurately furnish the proper quantities, items, sizes, weights and functions as required by the plans and specifications. If an opening has, through error, been omitted from the following hardware sets, it shall be the bidder's responsibility to supply hardware of equivalent quality and quantity, as that which is specified for a comparable opening.

SINGLE OUTSIDE DOOR (with lockset)

HW1

Doors 106A

Continuous gear hinge

Lockset (function E)

Closer

Weatherstripping

BURBANK BRANCH RENOVATIONS, PORTLAND PUBLIC LIBRARY

Door Bottom Sweep
Kickplate
Threshold

EMR

HW2

Doors 002A

Hinges
Closer
Lockset (utility function 1)
Wall stop
Smoke gasketing

SINGLE FIRE RATED EXIT

HW3

Doors 201A

Hinges
Closer
Exit Device (reuse existing exit device)
Kickplate
Wall Stop
Smoke gasketing

OFFICE (no smoke seals)

HW4

Doors 106B

Hinges
Locksets (classroom function 4)
Door Stop
Silencers

CORRIDOR (BI-SWING)

HW5

Doors 106D

Double-acting Spring Hinges
Push plates

BURBANK BRANCH RENOVATIONS, PORTLAND PUBLIC LIBRARY

Kickplates

END OF SECTION 087100

SECTION 088000 - GLAZING

PART 1 - GENERAL

1.1 RELATED DOCUMENTS

- A. Drawings and general provisions of the Contract, including General and Supplementary Conditions and Division 01 Specification Sections, apply to this Section.

1.2 SUMMARY

- A. Section includes glazing for the following products and applications, including those specified in other Sections where glazing requirements are specified by reference to this Section:
 - 1. Doors.
- B. Related Sections:
 - 1. Division 08 Section "Flush Wood Doors" for wood doors to be factory glazed.

1.3 DEFINITIONS

- A. Glass Manufacturers: Firms that produce primary glass, fabricated glass, or both, as defined in referenced glazing publications.
- B. Glass Thicknesses: Indicated by thickness designations in millimeters according to ASTM C 1036.
- C. Interspace: Space between lites of an insulating-glass unit.

1.4 ACTION SUBMITTALS

- A. Product Data: For each glass product and glazing material indicated.
- B. Glass Samples: For each type of the following products; 12 inches square.
 - 1. Insulating glass.
- C. Glazing Schedule: List glass types and thicknesses for each size opening and location. Use same designations indicated on Drawings.

1.5 INFORMATIONAL SUBMITTALS

- A. Product Certificates: For glass and glazing products, from manufacturer.

BURBANK BRANCH RENOVATIONS, PORTLAND PUBLIC LIBRARY

- B. Product Test Reports: Based on evaluation of comprehensive tests performed by a qualified testing agency, for insulating glass.
- C. Warranties: Sample of special warranties.

1.6 QUALITY ASSURANCE

- A. Manufacturer Qualifications for Insulating-Glass Units with Sputter-Coated, Low-E Coatings: A qualified insulating-glass manufacturer who is approved by coated-glass manufacturer.
- B. Glass Testing Agency Qualifications: A qualified independent testing agency accredited according to the NFRC CAP 1 Certification Agency Program.
- C. Source Limitations for Glass: Obtain insulating glass from single source from single manufacturer for each glass type.
- D. Source Limitations for Glazing Accessories: Obtain from single source from single manufacturer for each product and installation method.
- E. Glazing Publications: Comply with published recommendations of glass product manufacturers and organizations below, unless more stringent requirements are indicated. Refer to these publications for glazing terms not otherwise defined in this Section or in referenced standards.
 - 1. IGMMA Publication for Insulating Glass: SIGMA TM-3000, "North American Glazing Guidelines for Sealed Insulating Glass Units for Commercial and Residential Use."
- F. Safety Glazing Labeling: Where safety glazing labeling is indicated, permanently mark glazing with certification label of the SGCC or another certification agency acceptable to authorities having jurisdiction or the manufacturer. Label shall indicate manufacturer's name, type of glass, thickness, and safety glazing standard with which glass complies.

1.7 DELIVERY, STORAGE, AND HANDLING

- A. Protect glazing materials according to manufacturer's written instructions. Prevent damage to glass and glazing materials from condensation, temperature changes, direct exposure to sun, or other causes.
- B. Comply with insulating-glass manufacturer's written recommendations for venting and sealing units to avoid hermetic seal ruptures due to altitude change.

1.8 PROJECT CONDITIONS

- A. Environmental Limitations: Do not proceed with glazing when ambient and substrate temperature conditions are outside limits permitted by glazing material manufacturers and when glazing channel substrates are wet from rain, frost, condensation, or other causes.
 - 1. Do not install glazing sealants when ambient and substrate temperature conditions are outside limits permitted by sealant manufacturer or below 40 deg F.

1.9 WARRANTY

- A. Manufacturer's Warranty for Coated-Glass Products: Manufacturer's standard form in which coated-glass manufacturer agrees to replace coated-glass units that deteriorate within specified warranty period. Deterioration of coated glass is defined as defects developed from normal use that are not attributed to glass breakage or to maintaining and cleaning coated glass contrary to manufacturer's written instructions. Defects include peeling, cracking, and other indications of deterioration in coating.

1. Warranty Period: 10 years from date of Substantial Completion.

- B. Manufacturer's Warranty on Insulating Glass: Manufacturer's standard form in which insulating-glass manufacturer agrees to replace insulating-glass units that deteriorate within specified warranty period. Deterioration of insulating glass is defined as failure of hermetic seal under normal use that is not attributed to glass breakage or to maintaining and cleaning insulating glass contrary to manufacturer's written instructions. Evidence of failure is the obstruction of vision by dust, moisture, or film on interior surfaces of glass.

1. Warranty Period: 10 years from date of Substantial Completion.

PART 2 - PRODUCTS

2.1 GLASS PRODUCTS, GENERAL

- A. Thickness: Where glass thickness is indicated, it is a minimum. Provide glass lites in thicknesses as needed to comply with requirements indicated.

1. Minimum Glass Thickness for Exterior Lites: Not less than 6.0 mm.
2. Thickness of Tinted Glass: Provide same thickness for each tint color indicated throughout Project.

- B. Strength: Where float glass is indicated, provide annealed float glass, Kind HS heat-treated float glass, or Kind FT heat-treated float glass. Where heat-strengthened glass is indicated, provide Kind HS heat-treated float glass or Kind FT heat-treated float glass. Where fully tempered glass is indicated, provide Kind FT heat-treated float glass.

- C. Thermal and Optical Performance Properties: Provide glass with performance properties specified, as indicated in manufacturer's published test data, based on procedures indicated below:

1. For monolithic-glass lites, properties are based on units with lites 6.0 mm thick.
2. For insulating-glass units, properties are based on units of thickness indicated for overall unit and for each lite.
3. U-Factors: Center-of-glazing values, according to NFRC 100 and based on LBL's WINDOW 5.2 computer program, expressed as Btu/sq. ft. x h x deg F.
4. Solar Heat-Gain Coefficient and Visible Transmittance: Center-of-glazing values, according to NFRC 200 and based on LBL's WINDOW 5.2 computer program.
5. Visible Reflectance: Center-of-glazing values, according to NFRC 300.

2.2 GLASS PRODUCTS

- A. Heat-Treated Float Glass: ASTM C 1048; Type I; Quality-Q3; Class I (clear) unless otherwise indicated; of kind and condition indicated.
 - 1. Fabrication Process: By horizontal (roller-hearth) process with roll-wave distortion parallel to bottom edge of glass as installed unless otherwise indicated.
 - 2. For uncoated glass, comply with requirements for Condition A.
 - 3. For coated vision glass, comply with requirements for Condition C (other coated glass).

2.3 INSULATING GLASS

- A. Insulating-Glass Units: Factory-assembled units consisting of sealed lites of glass separated by a dehydrated interspace, qualified according to ASTM E 2190, and complying with other requirements specified.
 - 1. Sealing System: Dual seal, with silicone primary seal and butyl secondary seal.
 - 2. Spacer: Manufacturer's standard spacer material and construction.
 - 3. Desiccant: Molecular sieve or silica gel, or blend of both.
- B. Glass: Comply with applicable requirements in "Glass Products" Article as indicated by designations in "Insulating-Glass Types" Article.

2.4 GLAZING GASKETS

- A. Dense Compression Gaskets: Molded or extruded gaskets of profile and hardness required to maintain watertight seal, made from one of the following:
 - 1. Neoprene complying with ASTM C 864.
 - 2. EPDM complying with ASTM C 864.
 - 3. Silicone complying with ASTM C 1115.
 - 4. Thermoplastic polyolefin rubber complying with ASTM C 1115.
- B. Soft Compression Gaskets: Extruded or molded, closed-cell, integral-skinned EPDM, silicone, or thermoplastic polyolefin rubber gaskets complying with ASTM C 509, Type II, black; of profile and hardness required to maintain watertight seal.
 - 1. Application: Use where soft compression gaskets will be compressed by inserting dense compression gaskets on opposite side of glazing or pressure applied by means of pressure-glazing stops on opposite side of glazing.

2.5 GLAZING SEALANTS

- A. General:
 - 1. Compatibility: Provide glazing sealants that are compatible with one another and with other materials they will contact, including glass products, seals of insulating-glass units, and glazing channel substrates, under conditions of service and application, as demonstrated by sealant manufacturer based on testing and field experience.

2. Suitability: Comply with sealant and glass manufacturers' written instructions for selecting glazing sealants suitable for applications indicated and for conditions existing at time of installation.
 3. VOC Content: For sealants used inside of the weatherproofing system, not more than 250 g/L when calculated according to 40 CFR 59, Subpart D.
 4. Colors of Exposed Glazing Sealants: As selected by Architect from manufacturer's full range.
- B. Glazing Sealant: Neutral-curing silicone glazing sealant complying with ASTM C 920, Type S, Grade NS, Class 100/50, Use NT.
1. Products: Subject to compliance with requirements, provide one of the following:
 - a. Dow Corning Corporation; 790.
 - b. GE Advanced Materials - Silicones; SilPruf LM SCS2700.
 - c. May National Associates, Inc.; Bondaflex Sil 290.
 - d. Pecora Corporation; 890.
 - e. Sika Corporation, Construction Products Division; SikaSil-C990.
 - f. Tremco Incorporated; Spectrem 1.

2.6 GLAZING TAPES

- A. Back-Bedding Mastic Glazing Tapes: Preformed, butyl-based, 100 percent solids elastomeric tape; nonstaining and nonmigrating in contact with nonporous surfaces; with or without spacer rod as recommended in writing by tape and glass manufacturers for application indicated; and complying with ASTM C 1281 and AAMA 800 for products indicated below:
1. AAMA 804.3 tape, where indicated.
 2. AAMA 806.3 tape, for glazing applications in which tape is subject to continuous pressure.
 3. AAMA 807.3 tape, for glazing applications in which tape is not subject to continuous pressure.
- B. Expanded Cellular Glazing Tapes: Closed-cell, PVC foam tapes; factory coated with adhesive on both surfaces; and complying with AAMA 800 for the following types:
1. AAMA 810.1, Type 1, for glazing applications in which tape acts as the primary sealant.
 2. AAMA 810.1, Type 2, for glazing applications in which tape is used in combination with a full bead of liquid sealant.

2.7 MISCELLANEOUS GLAZING MATERIALS

- A. General: Provide products of material, size, and shape complying with referenced glazing standard, requirements of manufacturers of glass and other glazing materials for application indicated, and with a proven record of compatibility with surfaces contacted in installation.
- B. Cleaners, Primers, and Sealers: Types recommended by sealant or gasket manufacturer.

BURBANK BRANCH RENOVATIONS, PORTLAND PUBLIC LIBRARY

- C. Setting Blocks: Elastomeric material with a Shore, Type A durometer hardness of 85, plus or minus 5.
- D. Spacers: Elastomeric blocks or continuous extrusions of hardness required by glass manufacturer to maintain glass lites in place for installation indicated.
- E. Edge Blocks: Elastomeric material of hardness needed to limit glass lateral movement (side walking).
- F. Cylindrical Glazing Sealant Backing: ASTM C 1330, Type O (open-cell material), of size and density to control glazing sealant depth and otherwise produce optimum glazing sealant performance.

2.8 FABRICATION OF GLAZING UNITS

- A. Fabricate glazing units in sizes required to fit openings indicated for Project, with edge and face clearances, edge and surface conditions, and bite complying with written instructions of product manufacturer and referenced glazing publications, to comply with system performance requirements.

2.9 MONOLITHIC-GLASS TYPES

- A. Tempered Glass: Clear fully tempered float glass.
 - 1. Thickness: 6.0 mm.
 - 2. Provide safety glazing labeling.
 - 3. Application: Interior glass for doors.

2.10 INSULATING-GLASS TYPES

- A. Insulating Glass: Low-e-coated, clear insulating glass.
 - 1. Overall Unit Thickness: 1 inch.
 - 2. Thickness of Each Glass Lite: 6.0 mm.
 - 3. Outdoor Lite: Float glass.
 - 4. Interspace Content: Air.
 - 5. Indoor Lite: Float glass.
 - 6. Low-E Coating: Pyrolytic or sputtered on second or third surface.
 - 7. Provide tempered glass and safety glazing labeling where required by code.

PART 3 - EXECUTION

3.1 EXAMINATION

- A. Examine framing, glazing channels, and stops, with Installer present, for compliance with the following:

BURBANK BRANCH RENOVATIONS, PORTLAND PUBLIC LIBRARY

1. Manufacturing and installation tolerances, including those for size, squareness, and offsets at corners.
 2. Presence and functioning of weep systems.
 3. Minimum required face and edge clearances.
 4. Effective sealing between joints of glass-framing members.
- B. Proceed with installation only after unsatisfactory conditions have been corrected.

3.2 PREPARATION

- A. Clean glazing channels and other framing members receiving glass immediately before glazing. Remove coatings not firmly bonded to substrates.
- B. Examine glazing units to locate exterior and interior surfaces. Label or mark units as needed so that exterior and interior surfaces are readily identifiable. Do not use materials that will leave visible marks in the completed work.

3.3 GLAZING, GENERAL

- A. Comply with combined written instructions of manufacturers of glass, sealants, gaskets, and other glazing materials, unless more stringent requirements are indicated, including those in referenced glazing publications.
- B. Adjust glazing channel dimensions as required by Project conditions during installation to provide necessary bite on glass, minimum edge and face clearances, and adequate sealant thicknesses, with reasonable tolerances.
- C. Protect glass edges from damage during handling and installation. Remove damaged glass from Project site and legally dispose of off Project site. Damaged glass is glass with edge damage or other imperfections that, when installed, could weaken glass and impair performance and appearance.
- D. Apply primers to joint surfaces where required for adhesion of sealants, as determined by preconstruction testing.
- E. Install setting blocks in sill rabbets, sized and located to comply with referenced glazing publications, unless otherwise required by glass manufacturer. Set blocks in thin course of compatible sealant suitable for heel bead.
- F. Do not exceed edge pressures stipulated by glass manufacturers for installing glass lites.
- G. Provide spacers for glass lites where length plus width is larger than 50 inches.
 1. Locate spacers directly opposite each other on both inside and outside faces of glass. Install correct size and spacing to preserve required face clearances, unless gaskets and glazing tapes are used that have demonstrated ability to maintain required face clearances and to comply with system performance requirements.

BURBANK BRANCH RENOVATIONS, PORTLAND PUBLIC LIBRARY

2. Provide 1/8-inch minimum bite of spacers on glass and use thickness equal to sealant width. With glazing tape, use thickness slightly less than final compressed thickness of tape.
- H. Provide edge blocking where indicated or needed to prevent glass lites from moving sideways in glazing channel, as recommended in writing by glass manufacturer and according to requirements in referenced glazing publications.
- I. Set glass lites in each series with uniform pattern, draw, bow, and similar characteristics.
- J. Set glass lites with proper orientation so that coatings face exterior or interior as specified.

3.4 TAPE GLAZING

- A. Position tapes on fixed stops so that, when compressed by glass, their exposed edges are flush with or protrude slightly above sightline of stops.
- B. Install tapes continuously, but not necessarily in one continuous length. Do not stretch tapes to make them fit opening.
- C. Cover vertical framing joints by applying tapes to heads and sills first and then to jambs. Cover horizontal framing joints by applying tapes to jambs and then to heads and sills.
- D. Place joints in tapes at corners of opening with adjoining lengths butted together, not lapped. Seal joints in tapes with compatible sealant approved by tape manufacturer.
- E. Do not remove release paper from tape until right before each glazing unit is installed.
- F. Apply heel bead of elastomeric sealant.
- G. Center glass lites in openings on setting blocks and press firmly against tape by inserting dense compression gaskets formed and installed to lock in place against faces of removable stops. Start gasket applications at corners and work toward centers of openings.
- H. Apply cap bead of elastomeric sealant over exposed edge of tape.

3.5 SEALANT GLAZING (WET)

- A. Install continuous spacers, or spacers combined with cylindrical sealant backing, between glass lites and glazing stops to maintain glass face clearances and to prevent sealant from extruding into glass channel and blocking weep systems until sealants cure. Secure spacers or spacers and backings in place and in position to control depth of installed sealant relative to edge clearance for optimum sealant performance.
- B. Force sealants into glazing channels to eliminate voids and to ensure complete wetting or bond of sealant to glass and channel surfaces.
- C. Tool exposed surfaces of sealants to provide a substantial wash away from glass.

3.6 CLEANING AND PROTECTION

- A. Protect exterior glass from damage immediately after installation by attaching crossed streamers to framing held away from glass. Do not apply markers to glass surface. Remove nonpermanent labels and clean surfaces.
- B. Protect glass from contact with contaminating substances resulting from construction operations. If, despite such protection, contaminating substances do come into contact with glass, remove substances immediately as recommended in writing by glass manufacturer.
- C. Examine glass surfaces adjacent to or below exterior concrete and other masonry surfaces at frequent intervals during construction, but not less than once a month, for buildup of dirt, scum, alkaline deposits, or stains; remove as recommended in writing by glass manufacturer.
- D. Remove and replace glass that is broken, chipped, cracked, or abraded or that is damaged from natural causes, accidents, and vandalism, during construction period.
- E. Wash glass on both exposed surfaces in each area of Project not more than four days before date scheduled for inspections that establish date of Substantial Completion. Wash glass as recommended in writing by glass manufacturer.

END OF SECTION 088000

SECTION 092300 - GYPSUM PLASTERING

PART 1 - GENERAL

1.1 RELATED DOCUMENTS

- A. Drawings and general provisions of the Contract, including General and Supplementary Conditions and Division 01 Specification Sections, apply to this Section.

1.2 SUMMARY

- A. Section Includes:
 - 1. Cutting and patching of existing gypsum plasterwork.

1.3 ACTION SUBMITTALS

- A. Product Data: For each type of product indicated.

1.4 DELIVERY, STORAGE, AND HANDLING

- A. Store materials inside under cover and keep them dry and protected against damage from weather, direct sunlight, surface contamination, corrosion, construction traffic, and other causes.

1.5 PROJECT CONDITIONS

- A. Comply with ASTM C 842 requirements or gypsum plaster manufacturer's written recommendations, whichever are more stringent.
- B. Room Temperatures: Maintain temperatures at not less than 55 deg F or greater than 80 deg F for at least seven days before application of gypsum plaster, continuously during application, and for seven days after plaster has set or until plaster has dried.
- C. Avoid conditions that result in gypsum plaster drying out too quickly.
 - 1. Distribute heat evenly; prevent concentrated or uneven heat on plaster.
 - 2. Maintain relative humidity levels for prevailing ambient temperature that produce normal drying conditions.
 - 3. Ventilate building spaces in a manner that prevents drafts of air from contacting surfaces during plaster application and until plaster is dry.

PART 2 - PRODUCTS

2.1 GYPSUM BASE

- A. Provide one of the following thicknesses as required for matching thickness.
- B. Gypsum Base for Veneer Plaster: ASTM C 1396/C 1396M.
 - 1. Manufacturers: Subject to compliance with requirements, provide products by one of the following:
 - a. CertainTeed Corp.; ProRoc Veneer Plaster Base.
 - b. Georgia-Pacific Gypsum LLC, Subsidiary of Georgia Pacific; Tough Rock Veneer Plaster Base.
 - c. Lafarge North America Inc.; Plasterbase.
 - d. National Gypsum Company; Kal-Core Regular.
 - e. USG Corporation; Imperial Regular Gypsum Base.
 - 2. Thickness: 1/2 inch.
- C. Gypsum Base for Veneer Plaster, Type X: ASTM C 1396/C 1396M.
 - 1. Manufacturers: Subject to compliance with requirements, provide products by one of the following:
 - a. CertainTeed Corp.; ProRoc Veneer Plaster Base, Type X.
 - b. Georgia-Pacific Gypsum LLC, Subsidiary of Georgia Pacific; Tough Rock Fireguard Veneer Plaster Base.
 - c. National Gypsum Company; Kal-Core Fire-Shield, Type X.
 - d. USG Corporation; Imperial [Firecode] [Ultracode] Gypsum Base.
 - 2. Thickness: 5/8 inch.

2.2 JOINT REINFORCING MATERIALS

- A. General: Comply with joint strength requirements in ASTM C 587 and with gypsum veneer plaster manufacturer's written recommendations for each application indicated.
- B. Joint Tape:
 - 1. Gypsum Base for Veneer Plaster: As recommended by gypsum veneer plaster manufacturer for applications indicated.
- C. Embedding Material for Joint Tape:
 - 1. Gypsum Base for Veneer Plaster: As recommended by gypsum veneer plaster manufacturer for use with joint-tape material and gypsum veneer plaster applications indicated.

BURBANK BRANCH RENOVATIONS, PORTLAND PUBLIC LIBRARY

2.3 ACCESSORIES

- A. General: Comply with ASTM C 841 and coordinate depth of trim and accessories with thicknesses and number of plaster coats required.
- B. Manufacturers: Subject to compliance with requirements, available manufacturers offering products that may be incorporated into the Work include, but are not limited to, the following:
 - 1. Alabama Metal Industries Corporation; a Gibraltar Industries company.
 - 2. Clark Western Building Systems.
 - 3. Dietrich Metal Framing; a Worthington Industries company.
 - 4. MarinoWARE.
- C. Metal Accessories:
 - 1. Cornerite: Fabricated from expanded-metal lath with ASTM A 653/A 653M, G60, hot-dip galvanized zinc coating.
 - 2. Striplath: Fabricated from expanded-metal lath with ASTM A 653/A 653M, G60, hot-dip galvanized zinc coating.
 - 3. Cornerbeads: Fabricated from zinc-coated (galvanized) steel.
 - a. Small nose cornerbead with expanded flanges; use unless otherwise indicated.
 - 4. Casing Beads: Fabricated from zinc-coated (galvanized) steel; square-edged style; with expanded flanges.

2.4 MISCELLANEOUS MATERIALS

- A. Water for Mixing and Finishing Plaster: Potable and free of substances capable of affecting plaster set or of damaging plaster, lath, or accessories.
- B. Bonding Compound: ASTM C 631.

2.5 BASE-COAT PLASTER MATERIALS

- A. Base-Coat Plasters, General: ASTM C 28/C 28M.
- B. Lightweight Gypsum Ready-Mixed Plaster: With mill-mixed perlite aggregate.
 - 1. Products: Subject to compliance with requirements, available products that may be incorporated into the Work include, but are not limited to, the following:
 - a. National Gypsum Company; Gold Bond Gypsolite.
 - b. USG Corporation; Structo-Lite.

2.6 FINISH-COAT PLASTER MATERIALS

- A. Gypsum Ready-Mixed Finish Plaster: Manufacturer's standard, mill-mixed, gaged, interior finish.

BURBANK BRANCH RENOVATIONS, PORTLAND PUBLIC LIBRARY

1. Products: Subject to compliance with requirements, available products that may be incorporated into the Work include, but are not limited to, the following:
 - a. National Gypsum Company; Gold Bond Kal-Kote Smooth.
 - b. USG Corporation; Diamond Brand Interior Finish Plaster.

2.7 GYPSUM VENEER PLASTER

- A. Two-Component Gypsum Veneer Plaster: ASTM C 587, with separate formulations; one for base-coat application and one for finish-coat application over substrates.
 1. Base Coat:
 - a. Manufacturers: Subject to compliance with requirements, provide products by one of the following:
 - 1) National Gypsum Company; Kal-Kote Plaster Base.
 - 2) United States Gypsum Company; Diamond Veneer Basecoat Plaster.
 2. Smooth Finish Coat:
 - a. Manufacturers: Subject to compliance with requirements, provide products by one of the following:
 - 1) National Gypsum Company; Kal-Kote Smooth Finish.
 - 2) United States Gypsum Company; Diamond Veneer Finish Plaster.

2.8 PLASTER MIXES

- A. Mixing: Comply with ASTM C 842 and manufacturer's written instructions for applications indicated.

PART 3 - EXECUTION

3.1 EXAMINATION

- A. Examine nonstructural and structural metal framing, substrates, and hollow-metal frames, for compliance with requirements and other conditions affecting performance of the Work.
- B. Proceed with installation only after unsatisfactory conditions have been corrected.

3.2 PREPARATION

- A. Protect adjacent work from soiling, spattering, moisture deterioration, and other harmful effects caused by plastering.

3.3 INSTALLING PANELS

- A. Gypsum Base for Veneer Plaster: Apply according to ASTM C 844 unless manufacturer's written recommendations are more stringent.
 - 1. Do not allow gypsum base to degrade from exposure to sunlight, as evidenced by fading of paper facing.
 - 2. Erection Tolerance: No more than 1/16-inch offsets between planes of gypsum base panels, and 1/8 inch in 8 feet noncumulative, for level, plumb, warp, and bow.
- B. Fastener Spacing: Comply with ASTM C 844, manufacturer's written recommendations, and fire-resistance-rating requirements.
 - 1. Space screws a maximum of 12 inches o.c. along framing members for wall or ceiling application.

3.4 INSTALLING ACCESSORIES

- A. General: Install according to ASTM C 841.
- B. Cornerbeads: Install at external corners.
- C. Casing Beads: Install at terminations of plasterwork, except where plaster passes behind and is concealed by other work and where metal screeds, bases, or frames act as casing beads.

3.1 REPAIR OF SMALL CRACKS AND MINOR DAMAGE

- A. Remove existing damaged plaster back to a point which sound material is reached.
- B. Remove loose and foreign matter that could impair adhesion.
- C. Fill voids with plaster patching compound; apply with sufficient pressure to eliminate voids and ensure adhesion.
- D. Finish to match adjacent surfaces.

3.2 REPAIR OF LARGE CRACKS

- A. Remove existing damaged plaster back to a point which sound material is reached.
- B. Remove loose and foreign matter that could impair adhesion.
- C. Fill voids with plaster patching compound; apply with sufficient pressure to eliminate voids and ensure adhesion.
- D. Embed tape in wet compound. Apply additional compound to cover tape.
- E. Finish to match adjacent surfaces.

3.3 REPAIR OF DELAMINATED PLASTER LAYERS

- A. Remove existing damaged plaster back to a point which sound material is reached.

- B. Remove loose and foreign matter that could impair adhesion.
- C. Apply bonding agent in accordance with manufacturer's instruction.
- D. Fill voids with plaster patching compound; apply with sufficient pressure to eliminate voids and ensure adhesion.
- E. Finish to match adjacent surfaces.

3.4 REPAIR DAMAGED PLASTER OVER LATH

- A. Remove existing damaged plaster and lath down to framing.
- B. Install gypsum panels. Provide appropriate thickness to match adjacent finished surface.
- C. Apply brown, and finish coats to thickness to match existing plaster.
- D. Finish to match adjacent surfaces.

3.5 PLASTER APPLICATION FOR NEW WORK

- A. Gypsum Veneer Plaster Mixing: Mechanically mix gypsum veneer plaster materials to comply with ASTM C 843 and with gypsum veneer plaster manufacturer's written recommendations.
- B. Gypsum Veneer Plaster Application: Comply with ASTM C 843 and with veneer plaster manufacturer's written recommendations.
 - 1. Two-Component Gypsum Veneer Plaster:
 - a. Base Coat: Hand trowel or machine apply base coat over substrate to a uniform thickness of 1/16 to 3/32 inch. Fill all voids and imperfections.
 - b. Finish Coat: Trowel apply finish-coat plaster over base-coat plaster to a uniform thickness of 1/16 to 3/32 inch.
 - 2. Where gypsum veneer plaster abuts only metal door frames, windows, and other units, groove finish coat to eliminate spalling.
 - 3. Do not apply veneer plaster to gypsum base if paper facing has degraded from exposure to sunlight. Before applying veneer plaster, use remedial methods to restore bonding capability to degraded paper facing according to manufacturer's written recommendations.
- C. Plaster Finishes:
 - 1. Provide troweled finish to match existing, unless otherwise indicated.
- D. Concealed Plaster:
 - 1. Where plaster application will be concealed behind built-in cabinets, similar furnishings, and equipment, apply finish coat.
 - 2. Where plaster application will be concealed above suspended ceilings and in similar locations, finish coat may be omitted.

BURBANK BRANCH RENOVATIONS, PORTLAND PUBLIC LIBRARY

3. Where plaster application will be used as a base for adhesive application of tile and similar finishes, finish coat may be omitted.

3.6 CLEANING AND PROTECTION

- A. Remove temporary protection and enclosure of other work. Promptly remove plaster from door frames, windows, and other surfaces not indicated to be plastered. Repair floors, walls, and other surfaces stained, marred, or otherwise damaged during plastering.

END OF SECTION 092300

SECTION 092900 - GYPSUM BOARD

PART 1 - GENERAL

1.1 RELATED DOCUMENTS

- A. Drawings and general provisions of the Contract, including General and Supplementary Conditions and Division 01 Specification Sections, apply to this Section.

1.2 SUMMARY

- A. This Section includes the following:
 - 1. Interior gypsum board.

1.3 ACTION SUBMITTALS

- A. Product Data: For each type of product indicated.
- B. Samples: For the following products:
 - 1. Trim Accessories: Full-size Sample in 12-inch- long length for each trim accessory indicated.

1.4 STORAGE AND HANDLING

- A. Store materials inside under cover and keep them dry and protected against damage from weather, condensation, direct sunlight, construction traffic, and other causes. Stack panels flat to prevent sagging.

1.5 PROJECT CONDITIONS

- A. Environmental Limitations: Comply with ASTM C 840 requirements or gypsum board manufacturer's written recommendations, whichever are more stringent.
- B. Do not install interior products until installation areas are enclosed and conditioned.
- C. Do not install panels that are wet, those that are moisture damaged, and those that are mold damaged.
 - 1. Indications that panels are wet or moisture damaged include, but are not limited to, discoloration, sagging, or irregular shape.
 - 2. Indications that panels are mold damaged include, but are not limited to, fuzzy or splotchy surface contamination and discoloration.

PART 2 - PRODUCTS

2.1 PERFORMANCE REQUIREMENTS

- A. Fire-Resistance-Rated Assemblies: For fire-resistance-rated assemblies, provide materials and construction identical to those tested in assembly indicated according to ASTM E 119 by an independent testing agency.
- B. STC-Rated Assemblies: For STC-rated assemblies, provide materials and construction identical to those tested in assembly indicated according to ASTM E 90 and classified according to ASTM E 413 by an independent testing agency.

2.2 GYPSUM BOARD, GENERAL

- A. Size: Provide maximum lengths and widths available that will minimize joints in each area and that correspond with support system indicated.

2.3 INTERIOR GYPSUM BOARD

- A. Manufacturers: Subject to compliance with requirements, provide products by one of the following:
 - 1. American Gypsum.
 - 2. CertainTeed Corp.
 - 3. Georgia-Pacific Gypsum LLC.
 - 4. Lafarge North America Inc.
 - 5. National Gypsum Company.
 - 6. PABCO Gypsum.
 - 7. Temple-Inland.
 - 8. USG Corporation.
- B. Type X:
 - 1. Thickness: 5/8 inch.
 - 2. Long Edges: Tapered.
- C. Moisture- and Mold-Resistant Type: Complying with ASTM C1177/C 1177M, moisture- and mold-resistant core and surfaces.
 - 1. Core: 5/8 inch, Type X.
 - 2. Long Edges: Tapered.
 - 3. Mold/Mildew Resistance: 10 when tested in accordance with ASTM D 3273 Standard Test Method for Resistance to Growth of Mold on the Surface of Interior Coatings in an Environmental Chamber.
 - 4. Basis of design Product: "DensArmor Plus Fireguard" as manufactured by G-P Gypsum.
- D. Abuse-Resistant Type: Manufactured to produce greater resistance to surface indentation, through-penetration (impact resistance), and abrasion than standard, regular-type and Type X gypsum board.

BURBANK BRANCH RENOVATIONS, PORTLAND PUBLIC LIBRARY

1. Core: 5/8 inch, Type X.
2. Long Edges: Tapered.
3. Products: Subject to compliance with requirements, provide one of the following:
 - a. National Gypsum Company; Gold Bond Hi-Abuse Wallboard.
 - b. United States Gypsum Co.; SHEETROCK Brand Abuse-Resistant Gypsum Panels.

2.4 TRIM ACCESSORIES

A. Interior Trim: ASTM C 1047.

1. Material:
 - a. Galvanized or aluminum-coated steel sheet or rolled zinc.
 - b. Trim-Tex, Super Seal Tear Away™ L Bead where abutting exterior metal doors and windows.
2. Shapes:
 - a. Cornerbead.
 - b. LC-Bead: J-shaped; exposed long flange receives joint compound.
 - c. L-Bead: L-shaped; exposed long flange receives joint compound.

2.5 JOINT TREATMENT MATERIALS

A. General: Comply with ASTM C 475/C 475M.

B. Joint Tape:

1. Interior Gypsum Wallboard: Paper.

C. Joint Compound for Interior Gypsum Wallboard: For each coat use formulation that is compatible with other compounds applied on previous or for successive coats.

1. Prefilling: At open joints and damaged surface areas, use setting-type taping compound.
2. Embedding and First Coat: For embedding tape and first coat on joints, fasteners, and trim flanges, use setting-type taping or drying-type, all-purpose compound.
 - a. Use setting-type taping with mold-resistant gypsum wallboard.
3. Fill Coat: For second coat, use setting-type, sandable topping or drying-type, all-purpose compound.
4. Finish Coat: For third coat, use drying-type, all-purpose compound.
5. Skim Coat: Not required.

2.6 AUXILIARY MATERIALS

A. General: Provide auxiliary materials that comply with referenced installation standards and manufacturer's written recommendations.

BURBANK BRANCH RENOVATIONS, PORTLAND PUBLIC LIBRARY

- B. Steel Drill Screws: ASTM C 1002, unless otherwise indicated.
 - 1. Use screws complying with ASTM C 954 for fastening panels to steel members from 0.033 to 0.112 inch thick.
 - 2. For fastening cementitious backer units, use screws of type and size recommended by panel manufacturer.
- C. Sound Attenuation Blankets: ASTM C 665, Type I (blankets without membrane facing) produced by combining thermosetting resins with mineral fibers manufactured from glass, slag wool, or rock wool.
 - 1. Fire-Resistance-Rated Assemblies: Available products that may be incorporated into the Work include, but are not limited to, the following:
 - a. Roxul Inc.; Roxul AFB.
 - b. USG Corporation; ThermaFiber SAFB.
- D. Acoustical Joint Sealant: Manufacturer's standard nonsag, paintable, nonstaining latex sealant complying with ASTM C 834. Product effectively reduces airborne sound transmission through perimeter joints and openings in building construction as demonstrated by testing representative assemblies according to ASTM E 90.
 - 1. Products: Subject to compliance with requirements, available products that may be incorporated into the Work include, but are not limited to, the following:
 - a. Pecora Corporation; AC-20 FTR or AIS-919.
 - b. USG Corporation; SHEETROCK Acoustical Sealant.
 - 2. Provide sealants that have a VOC content of 250 g/L or less when calculated according to 40 CFR 59, Subpart D (EPA Method 24).
- E. Thermal Insulation: As specified in Division 07 Section "Thermal Insulation."
- F. Vapor Retarder: As specified in Division 07 Section "Thermal Insulation."

PART 3 - EXECUTION

3.1 EXAMINATION

- A. Examine areas and substrates, with Installer present, and including welded hollow-metal frames and framing, for compliance with requirements and other conditions affecting performance.
- B. Examine panels before installation. Reject panels that are wet, moisture damaged, and mold damaged.
- C. Proceed with installation only after unsatisfactory conditions have been corrected.

3.2 APPLYING AND FINISHING PANELS, GENERAL

- A. Comply with ASTM C 840.
- B. Install ceiling panels across framing to minimize the number of abutting end joints and to avoid abutting end joints in central area of each ceiling. Stagger abutting end joints of adjacent panels not less than one framing member.
- C. Install panels with face side out. Butt panels together for a light contact at edges and ends with not more than 1/16 inch of open space between panels. Do not force into place.
- D. Locate edge and end joints over supports, except in ceiling applications where intermediate supports or gypsum board back-blocking is provided behind end joints. Do not place tapered edges against cut edges or ends. Stagger vertical joints on opposite sides of partitions. Do not make joints other than control joints at corners of framed openings.
- E. Form control and expansion joints with space between edges of adjoining gypsum panels.
- F. Cover both faces of support framing with gypsum panels in concealed spaces (above ceilings, etc.), except in chases braced internally.
 - 1. Unless concealed application is indicated or required for sound, fire, air, or smoke ratings, coverage may be accomplished with scraps of not less than 8 sq. ft. in area.
 - 2. Fit gypsum panels around ducts, pipes, and conduits.
 - 3. Where partitions intersect structural members projecting below underside of floor/roof slabs and decks, cut gypsum panels to fit profile formed by structural members; allow 1/4- to 3/8-inch- wide joints to install sealant.
- G. Isolate perimeter of gypsum board applied to non-load-bearing partitions at structural abutments, except floors. Provide 1/4- to 1/2-inch- wide spaces at these locations, and trim edges with edge trim where edges of panels are exposed. Seal joints between edges and abutting structural surfaces with acoustical sealant.
- H. Wood Framing: Install gypsum panels over wood framing, with floating internal corner construction. Do not attach gypsum panels across the flat grain of wide-dimension lumber, including floor joists and headers. Float gypsum panels over these members, or provide control joints to counteract wood shrinkage.
- I. STC-Rated Assemblies: Seal construction at perimeters, behind control joints, and at openings and penetrations with a continuous bead of acoustical sealant. Install acoustical sealant at both faces of partitions at perimeters and through penetrations. Comply with ASTM C 919 and with manufacturer's written recommendations for locating edge trim and closing off sound-flanking paths around or through assemblies, including sealing partitions above acoustical ceilings.
- J. Fire-Resistance-Rated Gypsum Board Assemblies: Provide fire-resistive joint system at the top of fire-resistance-rated gypsum board assemblies. Provide firestop system around any structural penetration of wall assembly.
- K. Smoke-Rated Gypsum Board Assemblies: Provide a tight, taped joint at the top of smoke-rated assemblies and around any penetrations to assemblies at both side of the assembly. The use of acoustical sealant will be acceptable to fill gaps up to 3/8 inch wide.

3.3 APPLYING INTERIOR GYPSUM BOARD

- A. Install interior gypsum board in the following locations:
 - 1. Type X: Vertical and surfaces, unless otherwise indicated.
 - 2. Abuse-Resistant Type: As indicated on Drawings.
 - 3. Moisture- and Mold-Resistant Type: As indicated on Drawings.
- B. Single-Layer Application:
 - 1. On ceilings, apply gypsum panels before wall/partition board application to greatest extent possible and at right angles to framing, unless otherwise indicated.
 - 2. On partitions/walls, apply gypsum panels horizontally (perpendicular to framing), unless otherwise indicated or required by fire-resistance-rated assembly, and minimize end joints.
 - a. Stagger abutting end joints not less than one framing member in alternate courses of panels.
 - b. At stairwells and other high walls, install panels horizontally, unless otherwise indicated or required by fire-resistance-rated assembly.
 - 3. Fastening Methods: Apply gypsum panels to supports with steel drill screws.

3.4 INSTALLING TRIM ACCESSORIES

- A. General: For trim with back flanges intended for fasteners, attach to framing with same fasteners used for panels. Otherwise, attach trim according to manufacturer's written instructions.
- B. Control Joints: Install control joints at locations indicated on Drawings or according to ASTM C 840 and in specific locations approved by Architect for visual effect.
- C. Interior Trim: Install in the following locations:
 - 1. Cornerbead: Use at outside corners, unless otherwise indicated.
 - 2. LC-Bead: Use at exposed panel edges.
 - 3. L-Bead: Use where indicated.

3.5 FINISHING GYPSUM BOARD

- A. General: Treat gypsum board joints, interior angles, edge trim, control joints, penetrations, fastener heads, surface defects, and elsewhere as required to prepare gypsum board surfaces for decoration. Promptly remove residual joint compound from adjacent surfaces.
- B. Prefill open joints and damaged surface areas.
- C. Apply joint tape over gypsum board joints, except those with trim having flanges not intended for tape.

BURBANK BRANCH RENOVATIONS, PORTLAND PUBLIC LIBRARY

- D. Gypsum Board Finish Levels: Finish panels to levels indicated below and according to ASTM C 840:
1. Level 1: Ceiling plenum areas, concealed areas, and where indicated.
 2. Level 2: Where indicated on Drawings.
 3. Level 3: Where indicated on Drawings.
 4. Level 4: At panel surfaces that will be exposed to view, unless otherwise indicated.
 5. Level 5: Not required.
- E. Glass-Mat, Water-Resistant Backing Panels: Finish according to manufacturer's written instructions.

3.6 FIELD QUALITY CONTROL

- A. Above-Ceiling Observation: Before Contractor installs gypsum board ceilings, conduct an above-ceiling observation and report deficiencies in the Work observed. Do not proceed with installation of gypsum board to ceiling support framing until deficiencies have been corrected.
1. Complete the following in areas to receive gypsum board ceilings:
 - a. Installation, insulation, and leak and pressure testing of water piping systems.
 - b. Installation of air-duct systems.
 - c. Installation of air devices.
 - d. Installation of mechanical system control-air tubing.
 - e. Installation of ceiling support framing.
 - f. Installation of Penetration Firestopping and Fire-Resistive Joint Systems.

3.7 PROTECTION

- A. Protect installed products from damage from weather, condensation, direct sunlight, construction, and other causes during remainder of the construction period.
- B. Remove and replace panels that are wet, moisture damaged, and mold damaged.
1. Indications that panels are wet or moisture damaged include, but are not limited to, discoloration, sagging, or irregular shape.
 2. Indications that panels are mold damaged include, but are not limited to, fuzzy or splotchy surface contamination and discoloration.

END OF SECTION 092900

SECTION 096400 - WOOD FLOORING

PART 1 - GENERAL

1.1 RELATED DOCUMENTS

- A. Drawings and general provisions of the Contract, including General and Supplementary Conditions and Division 01 Specification Sections, apply to this Section.

1.2 SUMMARY

- A. This Section includes cutting, patching and refinishing existing field-finished wood flooring.

1.3 SUBMITTALS

- A. Product Data: For each type of product indicated.
- B. Shop Drawings: Show installation details including location and layout of each type of wood flooring and accessory.
- C. Samples for Verification: For each type of wood flooring and accessory, with stain color and finish required, approximately 12 inches long and of same thickness and material indicated for the Work and showing the full range of normal color and texture variations expected.

1.4 QUALITY ASSURANCE

- A. Source Limitations: For field-finished wood flooring, obtain each species, grade, and cut of wood from one source with resources to provide materials and products of consistent quality in appearance and physical properties.
- B. Hardwood Flooring: Comply with NOFMA's "Official Flooring Grading Rules" for species, grade, and cut.
 - 1. Certification: Provide flooring that carries NOFMA grade stamp on each bundle or piece.

1.5 DELIVERY, STORAGE, AND HANDLING

- A. Deliver wood flooring materials in unopened cartons or bundles.
- B. Protect wood flooring from exposure to moisture. Do not deliver wood flooring until after concrete, masonry, plaster, ceramic tile, and similar wet work is complete and dry.
- C. Store wood flooring materials in a dry, warm, ventilated, weathertight location.

1.6 PROJECT CONDITIONS

- A. Conditioning period begins not less than seven days before wood flooring installation, is continuous through installation, and continues not less than seven days after wood flooring installation.
 - 1. Environmental Conditioning: Maintain an ambient temperature between 65 and 75 deg F and relative humidity planned for building occupants in spaces to receive wood flooring during the conditioning period.
 - 2. Wood Flooring Conditioning: Move wood flooring into spaces where it will be installed, no later than the beginning of the conditioning period.
 - a. Do not install flooring until it adjusts to relative humidity of, and is at same temperature as, space where it is to be installed.
 - b. Open sealed packages to allow wood flooring to acclimatize immediately on moving flooring into spaces in which it will be installed.
- B. After conditioning period, maintain relative humidity and ambient temperature planned for building occupants.
- C. Install factory-finished wood flooring after other finishing operations, including painting, have been completed.

PART 2 - PRODUCTS

2.1 FIELD-FINISHED WOOD FLOORING

- A. Solid-Wood, Strip Flooring: Kiln dried to 6 to 9 percent maximum moisture content, tongue and groove and end matched, and with backs channeled (kerfed) for stress relief.
 - 1. Species and Grade: Select red oak.
 - 2. Cut: Plain sawn.
 - 3. Thickness: Match existing.
 - 4. Face Width: Match existing.
 - 5. Lengths: Random-length strips complying with applicable grading rules.
- B. Urethane Finish System: Complete solvent-based, oil-modified system of compatible components that is recommended by finish manufacturer for application indicated.
 - 1. VOC Content: When calculated according to 40 CFR 59, Subpart D (EPA Method 24), as follows:
 - a. Finish Coats and Floor Sealers: Not more than 350 g/L.
 - 2. Finish Coats: Formulated for multicoat application on wood flooring.
 - a. Available Products: Subject to compliance with requirements, products that may be incorporated into the Work include, but are not limited to, the following:
 - 1) Basic Coatings, Inc..

BURBANK BRANCH RENOVATIONS, PORTLAND PUBLIC LIBRARY

- 2) BonaKemi USA Inc..
- 3) Dura Seal, Sherwin-Williams Company (The).
- 4) Ecolab Inc., Huntington Brand.
- 5) Hillyard, Inc..
- 6) Polo-Plaz Coatings, National Coatings Company.

3. Floor Sealer: Pliable, penetrating type.

- C. Wood Filler: Compatible with finish system components and recommended by filler and finish manufacturers for use indicated. If required to match approved Samples, provide pigmented filler.

2.2 ACCESSORY MATERIALS

- A. Sheathing Paper: Plain building paper.
- B. Fasteners: As recommended by manufacturer, but not less than that recommended in NWFA's "Installation Guidelines: Wood Flooring."

PART 3 - EXECUTION

3.1 EXAMINATION

- A. Examine substrates, areas and conditions, with Installer present, for compliance with requirements for maximum moisture content, installation tolerances, and other conditions affecting performance of wood flooring.
1. Verify that substrates comply with tolerances and other requirements specified in other Sections.
 2. Proceed with installation only after unsatisfactory conditions have been corrected.

3.2 PREPARATION

- A. Broom or vacuum clean substrates to be covered immediately before product installation. After cleaning, examine substrates for moisture, alkaline salts, carbonation, or dust. Proceed with installation only after unsatisfactory conditions have been corrected.

3.3 INSTALLATION

- A. Comply with flooring manufacturer's written installation instructions, but not less than applicable recommendations in NWFA's "Installation Guidelines: Wood Flooring."
- B. Provide expansion space at walls and other obstructions and terminations of flooring of not less than 3/4 inch.
- C. Sheathing Paper: Where strip or plank flooring is nailed to solid-wood subfloor, install flooring over a layer of sheathing paper.

- D. Solid-Wood, Strip Flooring: Blind nail or staple flooring to substrate.
 - 1. For flooring of face width more than 3 inches, do the following:
 - a. Install countersunk screws at each end of each piece in addition to blind nailing. Cover screw heads with wood plugs glued flush with flooring.
 - b. Install no fewer than 2 countersunk nails at each end of each piece, spaced not more than 16 inches along length of each piece, in addition to blind nailing. Fill holes with matching wood filler.

3.4 FIELD FINISHING

- A. Machine-sand flooring to remove offsets, ridges, cups, and sanding-machine marks that would be noticeable after finishing. Vacuum and tack with a clean cloth immediately before applying finish.
 - 1. Comply with applicable recommendations in NWFA's "Installation Guidelines: Wood Flooring."
- B. Fill and repair wood flooring seams and defects.
- C. Cover wood flooring before finishing.
- D. Apply floor-finish materials in number of coats recommended by finish manufacturer for application indicated, but not less than one coat of floor sealer and three finish coats.
- E. Do not cover wood flooring after finishing until finish reaches full cure, and not before seven days after applying last finish coat.

3.5 PROTECTION

- A. Protect installed wood flooring during remainder of construction period with covering of heavy kraft paper or other suitable material. Do not use plastic sheet or film that might cause condensation.
 - 1. Do not move heavy and sharp objects directly over kraft-paper-covered wood flooring. Protect flooring with plywood or hardboard panels to prevent damage from storing or moving objects over flooring.

END OF SECTION 096400

SECTION 096513 - RESILIENT BASE AND ACCESSORIES

PART 1 - GENERAL

1.1 RELATED DOCUMENTS

- A. Drawings and general provisions of the Contract, including General and Supplementary Conditions and Division 01 Specification Sections, apply to this Section.

1.2 SUMMARY

- A. Section Includes:
 - 1. Resilient base.

1.3 ACTION SUBMITTALS

- A. Product Data: For each type of product indicated.
- B. Samples for Initial Selection: For each type of product indicated.
- C. Samples for Verification: For each type of product indicated, in manufacturer's standard-size Samples but not less than 12 inches long, of each resilient product color, texture, and pattern required.
- D. Product Schedule: For resilient products.

1.4 DELIVERY, STORAGE, AND HANDLING

- A. Store resilient products and installation materials in dry spaces protected from the weather, with ambient temperatures maintained within range recommended by manufacturer, but not less than 50 deg F or more than 90 deg F.

1.5 PROJECT CONDITIONS

- A. Maintain ambient temperatures within range recommended by manufacturer, but not less than 70 deg F or more than 95 deg F, in spaces to receive resilient products during the following time periods:
 - 1. 48 hours before installation.
 - 2. During installation.
 - 3. 48 hours after installation.
- B. After installation and until Substantial Completion, maintain ambient temperatures within range recommended by manufacturer, but not less than 55 deg F or more than 95 deg F.

BURBANK BRANCH RENOVATIONS, PORTLAND PUBLIC LIBRARY

- C. Install resilient products after other finishing operations, including painting, have been completed.

PART 2 - PRODUCTS

2.1 THERMOSET-RUBBER BASE

- A. Manufacturers: Subject to compliance with requirements, provide products by one of the following:
 - 1. Burke Mercer Flooring Products, Division of Burke Industries Inc.
 - 2. Flexco.
 - 3. Roppe Corporation, USA.
- B. Product Standard: ASTM F 1861, Type TS (rubber, vulcanized thermoset), Group I (solid, homogeneous).
 - 1. Style and Location:
 - a. Style A, Straight: Provide in areas with carpet.
 - b. Style B, Cove: Provide in areas with resilient flooring.
- C. Thickness: 0.125 inch.
- D. Height: 4 inches.
- E. Lengths: Coils in manufacturer's standard length.
- F. Outside Corners: Job formed or preformed.
- G. Inside Corners: Job formed or preformed.
- H. Colors: As selected by Architect from full range of industry colors.

2.2 VINYL MOLDING ACCESSORY

- A. Manufacturers: Subject to compliance with requirements, provide products by one of the following:
 - 1. Armstrong World Industries, Inc.
 - 2. Burke Mercer Flooring Products, Division of Burke Industries Inc.
 - 3. Flexco.
 - 4. Johnsonite; A Tarkett Company.
 - 5. Musson Rubber Company.
 - 6. Roppe Corporation, USA.
- B. Colors and Patterns: As selected by Architect from full range of industry colors.
- C. Profile and Dimensions:

BURBANK BRANCH RENOVATIONS, PORTLAND PUBLIC LIBRARY

1. Reducer Strip between Wood and Carpet: EG-XX-L by Johnsonite or approved substitute.

2.3 INSTALLATION MATERIALS

- A. Trowelable Leveling and Patching Compounds: Latex-modified, portland cement based or blended hydraulic-cement-based formulation provided or approved by manufacturer for applications indicated.
- B. Adhesives: Water-resistant type recommended by manufacturer to suit resilient products and substrate conditions indicated.
 1. Use adhesives that comply with the following limits for VOC content when calculated according to 40 CFR 59, Subpart D (EPA Method 24):
 - a. Cove Base Adhesives: Not more than 50 g/L.

PART 3 - EXECUTION

3.1 EXAMINATION

- A. Examine substrates, with Installer present, for compliance with requirements for maximum moisture content and other conditions affecting performance of the Work.
- B. Verify that finishes of substrates comply with tolerances and other requirements specified in other Sections and that substrates are free of cracks, ridges, depressions, scale, and foreign deposits that might interfere with adhesion of resilient products.
- C. Proceed with installation only after unsatisfactory conditions have been corrected.

3.2 PREPARATION

- A. Prepare substrates according to manufacturer's written instructions to ensure adhesion of resilient products.
- B. Fill cracks, holes, and depressions in substrates with trowelable leveling and patching compound and remove bumps and ridges to produce a uniform and smooth substrate.
- C. Do not install resilient products until they are same temperature as the space where they are to be installed.
 1. Move resilient products and installation materials into spaces where they will be installed at least 48 hours in advance of installation.
- D. Sweep and vacuum clean substrates to be covered by resilient products immediately before installation.

3.3 RESILIENT BASE INSTALLATION

- A. Comply with manufacturer's written instructions for installing resilient base.
- B. Apply resilient base to walls, columns, pilasters, casework and cabinets in toe spaces, and other permanent fixtures in rooms and areas where base is required.
- C. Install resilient base in lengths as long as practicable without gaps at seams and with tops of adjacent pieces aligned.
- D. Tightly adhere resilient base to substrate throughout length of each piece, with base in continuous contact with horizontal and vertical substrates.
- E. Do not stretch resilient base during installation.
- F. Preformed Corners: If selected by contractor, install preformed corners before installing straight pieces.
- G. Job-Formed Corners:
 - 1. Outside Corners: Use straight pieces of maximum lengths possible and form with returns not less than 3 inches in length.
 - a. Form without producing discoloration (whitening) at bends.
 - 2. Inside Corners: Use straight pieces of maximum lengths possible and form with returns not less than 3 inches in length.
 - a. Miter or cope corners to minimize open joints.

3.4 RESILIENT ACCESSORY INSTALLATION

- A. Comply with manufacturer's written instructions for installing resilient accessories.
- B. Resilient Molding Accessories: Butt to adjacent materials and tightly adhere to substrates throughout length of each piece. Install reducer strips at edges of carpet and resilient floor covering that would otherwise be exposed.

3.5 CLEANING AND PROTECTION

- A. Comply with manufacturer's written instructions for cleaning and protection of resilient products.
- B. Perform the following operations immediately after completing resilient product installation:
 - 1. Remove adhesive and other blemishes from exposed surfaces.
 - 2. Sweep and vacuum surfaces thoroughly.
 - 3. Damp-mop surfaces to remove marks and soil.

BURBANK BRANCH RENOVATIONS, PORTLAND PUBLIC LIBRARY

- C. Protect resilient products from mars, marks, indentations, and other damage from construction operations and placement of equipment and fixtures during remainder of construction period.
- D. Cover resilient products until Substantial Completion.

END OF SECTION 096513

SECTION 096813 - TILE CARPETING

PART 1 - GENERAL

1.1 RELATED DOCUMENTS

- A. Drawings and general provisions of the Contract, including General and Supplementary Conditions and Division 01 Specification Sections, apply to this Section.

1.2 SUMMARY

- A. Section includes modular carpet tile.
- B. Related Requirements:
 - 1. Section 096513 "Resilient Base and Accessories" for resilient wall base and accessories installed with carpet tile.

1.3 PREINSTALLATION MEETINGS

- A. Preinstallation Conference: Conduct conference at Project site.
 - 1. Review methods and procedures related to carpet tile installation including, but not limited to, the following:
 - a. Review delivery, storage, and handling procedures.
 - b. Review ambient conditions and ventilation procedures.
 - c. Review subfloor preparation procedures.
 - 2. Review methods and procedures related to curing and protection of concrete substrate.

1.4 ACTION SUBMITTALS

- A. Product Data: For each type of product.
 - 1. Include manufacturer's written data on physical characteristics, durability, and fade resistance.
 - 2. Include manufacturer's written installation recommendations for each type of substrate.
- B. Samples for Initial Selection: For each type of carpet tile.
 - 1. Include Samples of exposed edge, transition, and other accessory stripping involving color or finish selection.

BURBANK BRANCH RENOVATIONS, PORTLAND PUBLIC LIBRARY

- C. Samples for Verification: For each of the following products and for each color and texture required. Label each Sample with manufacturer's name, material description, color, pattern, and designation indicated on Drawings and in schedules.
 - 1. Carpet Tile: Full-size Sample.
 - 2. Exposed Edge, Transition, and Other Accessory Stripping: 12-inch-long Samples.
- D. Product Schedule: For carpet tile. Use same designations indicated on Drawings.
- E. Sustainable Product Certification: Provide ANSI/NSF 140 certification for carpet products.

1.5 INFORMATIONAL SUBMITTALS

- A. Qualification Data: For Installer.
- B. Product Test Reports: For carpet tile, for tests performed by a qualified testing agency.
- C. Sample Warranty: For special warranty.

1.6 CLOSEOUT SUBMITTALS

- A. Maintenance Data: For carpet tiles to include in maintenance manuals. Include the following:
 - 1. Methods for maintaining carpet tile, including cleaning and stain-removal products and procedures and manufacturer's recommended maintenance schedule.
 - 2. Precautions for cleaning materials and methods that could be detrimental to carpet tile.

1.7 MAINTENANCE MATERIAL SUBMITTALS

- A. Furnish extra materials, from the same product run, that match products installed and that are packaged with protective covering for storage and identified with labels describing contents.
 - 1. Carpet Tile: Full-size units equal to 5 percent of amount installed for each type indicated, but not less than 10 sq. yd..

1.8 QUALITY ASSURANCE

- A. Installer Qualifications: An experienced installer who is certified by the International Certified Floorcovering Installers Association at the Commercial II certification level.

1.9 DELIVERY, STORAGE, AND HANDLING

- A. Comply with CRI's "CRI Carpet Installation Standard."

BURBANK BRANCH RENOVATIONS, PORTLAND PUBLIC LIBRARY

1.10 FIELD CONDITIONS

- A. Comply with CRI's "CRI Carpet Installation Standard" for temperature, humidity, and ventilation limitations.
- B. Environmental Limitations: Do not deliver or install carpet tiles until spaces are enclosed and weathertight, wet-work in spaces is complete and dry, and ambient temperature and humidity conditions are maintained at levels planned for building occupants during the remainder of the construction period.
- C. Do not install carpet tiles over concrete slabs until slabs have cured and are sufficiently dry to bond with adhesive and concrete slabs have pH range recommended by carpet tile manufacturer.
- D. Where demountable partitions or other items are indicated for installation on top of carpet tiles, install carpet tiles before installing these items.

1.11 WARRANTY

- A. Special Warranty for Carpet Tiles: Manufacturer agrees to repair or replace components of carpet tile installation that fail in materials or workmanship within specified warranty period.
 - 1. Warranty does not include deterioration or failure of carpet tile due to unusual traffic, failure of substrate, vandalism, or abuse.
 - 2. Failures include, but are not limited to, the following:
 - a. More than 10 percent edge raveling, snags, and runs.
 - b. Dimensional instability.
 - c. Excess static discharge.
 - d. Loss of tuft-bind strength.
 - e. Loss of face fiber.
 - f. Delamination.
 - 3. Warranty Period: 10 years from date of Substantial Completion.

PART 2 - PRODUCTS

2.1 CARPET TILE

- A. Manufacturer: Subject to compliance with requirements, provide product by the following:
 - 1. [Beaulieu Group LLC.](#)
 - 2. [Bentley Prince Street, Inc.](#)
 - 3. [Interface, LLC.](#)
 - 4. [J&J Invision; J&J Industries, Inc.](#)
 - 5. [Mannington Mills, Inc.](#)
 - 6. [Mohawk Group \(The\); Mohawk Carpet, LLC.](#)
 - 7. [Patcraft; a division of Shaw Industries, Inc.](#)
 - 8. [Shaw Contract Group; a Berkshire Hathaway company.](#)

9. Tandus; a Tarkett company.
- B. Color: As selected by Architect from manufacturer's full range.
- C. Pattern: [**Match Architect's samples**] **<Insert pattern>**.
- D. Fiber Content: [**100 percent nylon 6, 6**] [**100 percent nylon 6**] [**100 percent polypropylene**] [**100 percent wool**] [**80 percent wool; 20 percent nylon 6, 6**] [**80 percent wool; 20 percent nylon 6**] **<Insert percentage>**.
- E. Fiber Type: **<Insert proprietary fiber type>**.
- F. Pile Characteristic: [**Level-loop**] [**Cut**] [**Cut-and-loop**] **<Insert construction>** pile.
- G. Yarn Twist: **<Insert TPI>**.
- H. Yarn Count: **<Insert count>**.
- I. Density: **<Insert oz./cu. yd. >**.
- J. Pile Thickness: **<Insert>** inches.
- K. Stitches: **<Insert stitches per inch>** per inch.
- L. Gage: **<Insert ends per inch>**.
- M. Surface Pile Weight: **<Insert oz./sq. yd. >** oz./sq. yd..
- N. Total Weight: **<Insert oz./sq. yd. >** for finished carpet tile.
- O. Primary Backing/Backcoating: [**Manufacturer's standard composite materials**] [**PVC**] [**Fiberglass-reinforced PVC**] [**Fiberglass-reinforced amorphous resin**] [**Reinforced polyurethane composite cushion**] [**Reinforced polyurethane composite**] [**Reinforced thermoplastic copolymer**] **<Insert specific primary backing materials; consult manufacturers>**.
- P. Secondary Backing: [**Manufacturer's standard material**] **<Insert specific secondary backing material>**.
- Q. Backing System: **<Insert proprietary name>**.
- R. Size: [**18 by 18 inches**] [**24 by 24 inches**] [**18 by 36 inches**] [**36 by 36 inches**] **<Insert dimensions>**.
- S. Applied Treatments:
1. Soil-Resistance Treatment: Manufacturer's standard treatment.
 2. Antimicrobial Treatment: Manufacturer's standard treatment that protects carpet tiles as follows:

BURBANK BRANCH RENOVATIONS, PORTLAND PUBLIC LIBRARY

- a. Antimicrobial Activity: Not less than 2-mm halo of inhibition for gram-positive bacteria, not less than 1-mm halo of inhibition for gram-negative bacteria, and no fungal growth, according to AATCC 174.

T. Sustainable Design Requirements:

1. Sustainable Product Certification: [**Silver**] [**Gold**] [**Platinum**] level certification according to ANSI/NSF 140.

U. Performance Characteristics:

1. Flooring Radiant Panel: ASTM E648 Direct Glue Down Mode – Class 1
2. NBS Smoke Chamber: ASTM E662 Flaming Mode – 450 or less
3. Electrostatic Propensity: Less than [**3.5**] [**3.0**] kV per AATCC 134.
4. Environmental Requirements: Provide carpet that complies with testing and product requirements of Carpet and Rug Institute's "Green Label Plus" program.

2.2 INSTALLATION ACCESSORIES

- A. Trowelable Leveling and Patching Compounds: Latex-modified, hydraulic-cement-based formulation provided or recommended by carpet tile manufacturer.
- B. Adhesives: Water-resistant, mildew-resistant, nonstaining, pressure-sensitive type to suit products and subfloor conditions indicated, that comply with flammability requirements for installed carpet tile, and are recommended by carpet tile manufacturer for releasable installation.
- C. Edge/Transition Strips: Refer to Section 096513 “Resilient Base and Accessories.”

PART 3 - EXECUTION

3.1 EXAMINATION

- A. Examine substrates, areas, and conditions, with Installer present, for compliance with requirements for maximum moisture content, alkalinity range, installation tolerances, and other conditions affecting carpet tile performance.
- B. Examine carpet tile for type, color, pattern, and potential defects.
- C. Wood Subfloors: Verify the following:
 1. Underlayment over subfloor complies with requirements specified in Section 061600 "Sheathing."
 2. Underlayment surface is free of irregularities and substances that may interfere with adhesive bond or show through surface.
- D. Proceed with installation only after unsatisfactory conditions have been corrected.

BURBANK BRANCH RENOVATIONS, PORTLAND PUBLIC LIBRARY

3.2 PREPARATION

- A. General: Comply with CRI's "Carpet Installation Standards" and with carpet tile manufacturer's written installation instructions for preparing substrates indicated to receive carpet tile.
- B. Use trowelable leveling and patching compounds, according to manufacturer's written instructions, to fill cracks, holes, depressions, and protrusions in substrates. Fill or level cracks, holes and depressions 1/8 inch wide or wider, and protrusions more than 1/32 inch unless more stringent requirements are required by manufacturer's written instructions.
- C. Concrete Substrates: Remove coatings, including curing compounds, and other substances that are incompatible with adhesives and that contain soap, wax, oil, or silicone, without using solvents. Use mechanical methods recommended in writing by adhesive and carpet tile manufacturers.
- D. Broom and vacuum clean substrates to be covered immediately before installing carpet tile.

3.3 INSTALLATION

- A. General: Comply with CRI's "CRI Carpet Installation Standard," Section 18, "Modular Carpet" and with carpet tile manufacturer's written installation instructions.
- B. Installation Method: As recommended in writing by carpet tile manufacturer.
- C. Maintain dye-lot integrity. Do not mix dye lots in same area.
- D. Maintain pile-direction patterns recommended in writing by carpet tile manufacturer.
- E. Cut and fit carpet tile to butt tightly to vertical surfaces, permanent fixtures, and built-in furniture including cabinets, pipes, outlets, edgings, thresholds, and nosings. Bind or seal cut edges as recommended by carpet tile manufacturer.
- F. Extend carpet tile into toe spaces, door reveals, closets, open-bottomed obstructions, removable flanges, alcoves, and similar openings.
- G. Maintain reference markers, holes, and openings that are in place or marked for future cutting by repeating on carpet tile as marked on subfloor. Use nonpermanent, nonstaining marking device.
- H. Install pattern parallel to walls and borders.
- I. Access Flooring: Stagger joints of carpet tiles so carpet tile grid is offset from access flooring panel grid. Do not fill seams of access flooring panels with carpet adhesive; keep seams free of adhesive.

3.4 CLEANING AND PROTECTION

- A. Perform the following operations immediately after installing carpet tile:

BURBANK BRANCH RENOVATIONS, PORTLAND PUBLIC LIBRARY

1. Remove excess adhesive and other surface blemishes using cleaner recommended by carpet tile manufacturer.
 2. Remove yarns that protrude from carpet tile surface.
 3. Vacuum carpet tile using commercial machine with face-beater element.
- B. Protect installed carpet tile to comply with CRI's "Carpet Installation Standard," Section 20, "Protecting Indoor Installations."
- C. Protect carpet tile against damage from construction operations and placement of equipment and fixtures during the remainder of construction period. Use protection methods indicated or recommended in writing by carpet tile manufacturer.

END OF SECTION 096813

SECTION 099113 - EXTERIOR PAINTING

PART 1 - GENERAL

1.1 RELATED DOCUMENTS

- A. Drawings and general provisions of the Contract, including General and Supplementary Conditions and Division 01 Specification Sections, apply to this Section.

1.2 SUMMARY

- A. This Section includes surface preparation and the application of paint systems on the following exterior substrates:
 - 1. Galvanized metal.
 - 2. Wood.
- B. This Section includes exposed exterior items and surfaces with low VOC coatings complying with ME DEP regulations.
- C. Related Sections include the following:
 - 1. Division 09 Section "Interior Painting" for surface preparation and the application of paint systems on interior substrates.

1.3 ACTION SUBMITTALS

- A. Product Data: For each type of product. Include preparation requirements and application instructions.
- B. Samples for Initial Selection: For each type of topcoat product.
- C. Samples for Verification: For each type of paint system and each color and gloss of topcoat.
 - 1. Submit Samples on rigid backing, 8 inches square.
 - 2. Step coats on Samples to show each coat required for system.
 - 3. Label each coat of each Sample.
 - 4. Label each Sample for location and application area.
- D. Product List: For each product indicated, include the following:
 - 1. Cross-reference to paint system and locations of application areas. Use same designations indicated on Drawings and in schedules.
 - 2. VOC content.

BURBANK BRANCH RENOVATIONS, PORTLAND PUBLIC LIBRARY

1.4 QUALITY ASSURANCE

- A. **Applicator Qualifications:** Engage an experienced Applicator who has completed painting system applications similar in material, design, and extent to those indicated for this Project, whose work has resulted in applications with a record of successful in-service performance.
- B. **Source Limitations:** Obtain primers and undercoat materials for each coating system from the same manufacturer as the finish coats.

1.5 DELIVERY, STORAGE, AND HANDLING

- A. Store materials not in use in tightly covered containers in well-ventilated areas with ambient temperatures continuously maintained at not less than 45 deg F.
 - 1. Maintain containers in clean condition, free of foreign materials and residue.
 - 2. Remove rags and waste from storage areas daily.

1.6 PROJECT CONDITIONS

- A. Apply paints only when temperature of surfaces to be painted and ambient air temperatures are between 50 and 95 deg F.
- B. Do not apply paints in snow, rain, fog, or mist; when relative humidity exceeds 85 percent; at temperatures less than 5 deg F above the dew point; or to damp or wet surfaces.

PART 2 - PRODUCTS

2.1 MANUFACTURERS

- A. **Available Manufacturers:** Subject to compliance with requirements, manufacturers offering products that may be incorporated into the Work include, but are not limited to, the following:
 - 1. Benjamin Moore & Co.
 - 2. California Paints.
 - 3. PPG Architectural Finishes, Inc. (Pittsburgh Paints, Glidden Professional, Flood Stains)
 - 4. Sherwin-Williams Company (The).

2.2 PAINT, GENERAL

- A. **Material Compatibility:**
 - 1. Provide materials for use within each paint system that are compatible with one another and substrates indicated, under conditions of service and application as demonstrated by manufacturer, based on testing and field experience.
 - 2. For each coat in a paint system, provide products recommended in writing by manufacturers of topcoat for use in paint system and on substrate indicated.

BURBANK BRANCH RENOVATIONS, PORTLAND PUBLIC LIBRARY

- B. VOC Compliance for Exterior Paints and Coatings: Provide the manufacturer's formulation for the products specified below that are VOC compliant with the State of Maine Department of Environmental Protection Regulation, "Chapter 151: Architectural and Industrial Maintenance (AIM) Coatings" and the following chemical restrictions expressed in grams per liter:
1. Flat Paints and Coatings: VOC content of not more than 100 g/L.
 2. Non-Flat Paints and Coatings: VOC content of not more than 150 g/L.
 3. Non-Flat Paints and Coatings - High Gloss: VOC content of not more than 250 g/L.
 4. Anticorrosive (Rust Preventative) Coatings: VOC content of not more than 400 g/L.
 5. Fire Resistant Coatings: VOC content of not more than 350 g/L.
 6. Industrial Maintenance Coatings (IMC): VOC content of not more than 340 g/L.
 7. Primers, Sealers, and Undercoaters: VOC content of not more than 200 g/L.
 8. Quick-Dry Enamels: VOC content of not more than 250 g/L.
 9. Quick-Dry Primers, Sealers, and Undercoaters: VOC content of not more than 200 g/L.
 10. Specialty Primers, Sealers, and Undercoaters: VOC content of not more than 350 g/L.
 11. Wood Preservatives: VOC content of not more than 350 g/L.
- C. Colors: Provide color selections made by the Architect. Allow for up to 5 different color selections.

2.3 METAL PRIMERS

- A. Galvanized Metal Primer: Factory-formulated galvanized metal primer for exterior application.
1. Benjamin Moore; Moore's IMC Acrylic Metal Primer No. M04.
 2. Devco Coatings: 4020-1000 Devflex 4020PF DTM Primer & Flat Finish. (91 g/L)
 3. Pittsburgh Paints: 90-709 Pitt-Tech One Pack Interior/Exterior Primer/Finish DTM Industrial Enamel. (123 g/L)
 4. Sherwin-Williams; IMC DTM Acrylic Primer/Finish, B66W1. (150 g/L)

2.4 WOOD PRIMERS

- A. Exterior Latex Wood Primer: Factory-formulated acrylic wood primer for exterior application.
1. Cal: Trouble-Shooter 100% Acrylic Latex Primer 45100.
 2. Glidden Professional; 6001-1200, Hydrosealer Primer Sealer. (100g/L)
 3. Moore; Super Spec Latex Exterior Primer #169.
 4. Pittsburgh Paints; 6-609 SpeedHide House and Trim Wood Primer Flat. (89 g/L)
 5. S-W: A-100 Exterior Latex Primer B42W41 Series. (87 g/L)
- B. Wood-Knot Sealer: Sealer recommended in writing by topcoat manufacturer for use in paint system indicated.

2.5 EXTERIOR LATEX PAINTS

- A. Low-Luster Acrylic Latex Paint:
1. Cal: 100% Acrylic Latex House & Trim Paint, Eggshell Finish 40100.

BURBANK BRANCH RENOVATIONS, PORTLAND PUBLIC LIBRARY

2. Glidden Professional: 2412-XXXXV Ultrahide 150 Exterior Satin Paint. (50 g/L)
3. Moore: Super Spec Low Lustre Latex House Paint #185.
4. PPG: Speedhide Exterior Satin Latex, 6-2000XI Series. (<50 g/L)
5. S-W: SuperPaint Exterior Latex Satin, A89-100 Series. (49 g/L)

B. Semi-Gloss Acrylic Latex Paint:

1. Cal: 100% Acrylic Latex House & Trim Paint, Satin Gloss 40200.
2. Glidden Professional: 2416-XXXXV, Ultrahide 150 Exterior Semi-Gloss Paint. (50 g/L)
3. Moore: Super Spec Latex House & Trim Paint #170.
4. PPG: Speedhide Exterior Semi-Gloss Latex, 6-900XI Series. (<50 g/L)
5. S-W: SuperPaint Exterior Latex Gloss, A84 Series. (132 g/L)

C. Exterior Semi-Gloss Acrylic Enamel: Factory-formulated semi-gloss acrylic enamel for exterior application.

1. Benjamin Moore; DTM Acrylic Semi-Gloss Enamel M29: Applied at a dry film thickness of not less than 2.0 mils.
2. California Paints: Rust Stop DTM 100% Acrylic Semi-Gloss, 10XX.
3. Devco Coatings; 4216-XXXX, High Performance Waterborne Acrylic Semi-Gloss Enamel.
4. Pittsburgh Paints: 6-900XI Speedhide Exterior Semi-Gloss Latex: Applied at a dry film thickness of not less than 1.5 mils.
5. Sherwin-Williams; IMC DTM Acrylic Coating Semi-Gloss (Waterborne) B66W200 Series. (250 g/L)

PART 3 - EXECUTION

3.1 EXAMINATION

- A. Examine substrates and conditions, with Applicator present, for compliance with requirements for maximum moisture content and other conditions affecting performance of work.
- B. Maximum Moisture Content of Substrates: When measured with an electronic moisture meter as follows:
 1. Wood: 15 percent.
- C. Verify suitability of substrates, including surface conditions and compatibility with existing finishes and primers.
- D. Begin coating application only after unsatisfactory conditions have been corrected and surfaces are dry.
 1. Beginning coating application constitutes Contractor's acceptance of substrates and conditions.

3.2 PREPARATION

- A. Comply with manufacturer's written instructions and recommendations in "MPI Architectural Painting Specification Manual" applicable to substrates and paint systems indicated.
- B. Remove plates, machined surfaces, and similar items already in place that are not to be painted. If removal is impractical or impossible because of size or weight of item, provide surface-applied protection before surface preparation and painting.
 - 1. After completing painting operations, use workers skilled in the trades involved to reinstall items that were removed. Remove surface-applied protection if any.
 - 2. Do not paint over labels of independent testing agencies or equipment name, identification, performance rating, or nomenclature plates.
- C. Clean substrates of substances that could impair bond of paints, including dirt, oil, grease, and incompatible paints and encapsulants.
 - 1. Remove incompatible primers and reprime substrate with compatible primers as required to produce paint systems indicated.
- D. Galvanized-Metal Substrates: Remove grease and oil residue from galvanized sheet metal fabricated from coil stock by mechanical methods to produce clean, lightly etched surfaces that promote adhesion of subsequently applied paints. Uniformly abrade galvanized surfaces with a palm sander and 60 grit aluminum oxide so surface is free of oil and surface contaminants.
- E. Wood Substrates:
 - 1. Scrape and clean knots, and apply coat of knot sealer before applying primer.
 - 2. Sand surfaces that will be exposed to view, and dust off.
 - 3. Prime edges, ends, faces, undersides, and backsides of wood.
 - 4. After priming, fill holes and imperfections in the finish surfaces with putty or plastic wood filler. Sand smooth when dried.

3.3 APPLICATION

- A. Apply paints according to manufacturer's written instructions.
 - 1. Use applicators and techniques suited for paint and substrate indicated.
 - 2. Paint surfaces behind movable items same as similar exposed surfaces. Before final installation, paint surfaces behind permanently fixed items with prime coat only.
 - 3. Paint both sides and edges of exterior doors and entire exposed surface of exterior door frames.
 - 4. Paint entire exposed surface of window frames and sashes.
 - 5. Do not paint over labels of independent testing agencies or equipment name, identification, performance rating, or nomenclature plates.
 - 6. Apply an additional coat of primer on metal surfaces that have been shop primed.
- B. Tinting: Tint primer of colors such as reds, yellows, and oranges with a gray basecoat system designed to help provide color coverage.

BURBANK BRANCH RENOVATIONS, PORTLAND PUBLIC LIBRARY

- C. If undercoats or other conditions show through topcoat, apply additional coats until cured film has a uniform paint finish, color, and appearance. Give special attention to ensure edges, corners, crevices, welds, and exposed fasteners receive a dry film thickness equivalent to that of flat surfaces. When using colors such as red, yellow or orange, an extra coat of finish may be necessary. Notify Architect when additional coats do not fix the problem.
- D. Apply paints to produce surface films without cloudiness, spotting, holidays, laps, brush marks, roller tracking, runs, sags, ropiness, or other surface imperfections. Cut in sharp lines and color breaks.

3.4 CLEANING AND PROTECTION

- A. At end of each workday, remove rubbish, empty cans, rags, and other discarded materials from Project site.
- B. After completing paint application, clean spattered surfaces. Remove spattered paints by washing, scraping, or other methods. Do not scratch or damage adjacent finished surfaces.
- C. Protect work of other trades against damage from paint application. Correct damage to work of other trades by cleaning, repairing, replacing, and refinishing, as approved by Architect, and leave in an undamaged condition.
- D. At completion of construction activities of other trades, touch up and restore damaged or defaced painted surfaces.

3.5 EXTERIOR PAINTING SCHEDULE

- A. VOC Compliance, General: Provide the manufacturers' formulations for the products specified below that comply with the VOC requirements for the State of Maine Department of Environmental Protection in paragraph 2.02.C of this Section.
- B. Galvanized-Metal Substrates: Provide the following finish systems over exterior hollow metal doors and frames:
 - 1. Semi-Gloss Acrylic-Enamel Finish: Two finish coats over a rust-inhibitive primer.
 - a. Primer: Exterior galvanized metal primer.
 - b. Finish Coats: Exterior semi-gloss acrylic enamel.
- C. Dressed Lumber Substrates: Including wood trim. Provide the following paint finish systems over new wood surfaces:
 - 1. Latex System:
 - a. Prime Coat: Exterior latex wood primer.
 - b. Intermediate Coat: Acrylic latex matching topcoat.
 - c. Topcoat: Low-luster or Semigloss acrylic latex paint to match existing.
- D. Wood Panel Substrates: Including MDO plywood siding.

BURBANK BRANCH RENOVATIONS, PORTLAND PUBLIC LIBRARY

1. Latex System:
 - a. Prime Coat: Exterior latex wood primer.
 - b. Intermediate Coat: Acrylic latex matching topcoat.
 - c. Topcoat: Low-luster or Semigloss acrylic latex paint to match existing.

END OF SECTION 099113

SECTION 099123 - INTERIOR PAINTING

PART 1 - GENERAL

1.1 RELATED DOCUMENTS

- A. Drawings and general provisions of the Contract, including General and Supplementary Conditions and Division 01 Specification Sections, apply to this Section.

1.2 SUMMARY

- A. This Section includes surface preparation and the application of paint systems on the following interior substrates:
 - 1. Steel.
 - 2. Galvanized metal.
 - 3. Wood.
 - 4. Gypsum board.
 - 5. Plaster.
- B. This Section includes exposed interior items and surfaces with low VOC coatings complying with ME DEP regulations.
- C. Related Sections include the following:
 - 1. Division 05 Sections for shop priming of metal substrates with primers specified in this Section.
 - 2. Division 06 Sections for shop priming carpentry with primers specified in this Section.
 - 3. Division 08 Sections for factory priming windows and doors with primers specified in this Section.
 - 4. Division 09 painting Sections for special-use coatings.
 - 5. Division 09 Section "Exterior Painting" for surface preparation and the application of paint systems on exterior substrates.

1.3 ACTION SUBMITTALS

- A. Product Data: For each type of product. Include preparation requirements and application instructions.
- B. Samples for Initial Selection: For each type of topcoat product.
- C. Samples for Verification: For each type of paint system and in each color and gloss of topcoat.
 - 1. Submit Samples on rigid backing, 8 inches square.
 - 2. Step coats on Samples to show each coat required for system.
 - 3. Label each coat of each Sample.
 - 4. Label each Sample for location and application area.

BURBANK BRANCH RENOVATIONS, PORTLAND PUBLIC LIBRARY

- D. Product List: For each product indicated, include the following:
 - 1. Cross-reference to paint system and locations of application areas. Use same designations indicated on Drawings and in schedules.
 - 2. VOC content.

1.4 MAINTENANCE MATERIAL SUBMITTALS

- A. Furnish extra materials that match products installed and that are packaged with protective covering for storage and identified with labels describing contents.
 - 1. Paint: 5 percent, but not less than 1 gal. of each material and color applied.
- B. Coating Maintenance Manual: Upon conclusion of the project, the Contractor or paint manufacturer/supplier shall furnish a coating maintenance manual, such as Sherwin-Williams "Custodian Project Color and Product Information" report or equal. Manual shall include an Area Summary with finish schedule, Area Detail designating where each product/color/finish was used, product data pages, Material Safety Data Sheets, care and cleaning instructions, touch-up procedures, and color samples of each color and finish used.

1.5 QUALITY ASSURANCE

- A. Applicator Qualifications: Engage an experienced Applicator who has completed painting system applications similar in material, design, and extent to those indicated for this Project, whose work has resulted in applications with a record of successful in-service performance.
- B. Source Limitations: Obtain primers and undercoat materials for each coating system from the same manufacturer as the finish coats.

1.6 DELIVERY, STORAGE, AND HANDLING

- A. Store materials not in use in tightly covered containers in well-ventilated areas with ambient temperatures continuously maintained at not less than 45 deg F.
 - 1. Maintain containers in clean condition, free of foreign materials and residue.
 - 2. Remove rags and waste from storage areas daily.

1.7 PROJECT CONDITIONS

- A. Apply paints only when temperature of surfaces to be painted and ambient air temperatures are between 50 and 95 deg F.
- B. Do not apply paints when relative humidity exceeds 85 percent; at temperatures less than 5 deg F above the dew point; or to damp or wet surfaces.

PART 2 - PRODUCTS

2.1 MANUFACTURERS

- A. Available Manufacturers: Subject to compliance with requirements, manufacturers offering products that may be incorporated into the Work include, but are not limited to, the following:
1. Benjamin Moore & Co.
 2. California Paints.
 3. PPG Architectural Finishes, Inc. (Pittsburgh Paints, Glidden Professional, Flood Stains)
 4. Sherwin-Williams Company (The).
- B. Products: Subject to compliance with requirements, provide one of the products listed in other Part 2 articles for the paint category indicated.

2.2 PAINT, GENERAL

- A. Material Compatibility:
1. Provide materials for use within each paint system that are compatible with one another and substrates indicated, under conditions of service and application as demonstrated by manufacturer, based on testing and field experience.
 2. For each coat in a paint system, provide products recommended in writing by manufacturers of topcoat for use in paint system and on substrate indicated.
- B. VOC Compliance for Interior Paints and Coatings: Provide the manufacturer's formulation for the products specified below that are VOC compliant with the State of Maine Department of Environmental Protection Regulation, "Chapter 151: Architectural and Industrial Maintenance (AIM) Coatings" and the following chemical restrictions expressed in grams per liter:
1. Flat Paints and Coatings: VOC content of not more than 100 g/L.
 2. Non-Flat Paints and Coatings: VOC content of not more than 150 g/L.
 3. Non-Flat Paints and Coatings - High Gloss: VOC content of not more than 250 g/L.
 4. Anticorrosive (Rust Preventative) Coatings: VOC content of not more than 400 g/L.
 5. Fire Resistive Coatings: VOC content of not more than 350 g/L.
 6. Industrial Maintenance Coatings (IMC): VOC content of not more than 340 g/L.
 7. Primers, Sealers, and Undercoaters: VOC content of not more than 200 g/L.
 8. Quick-Dry Enamels: VOC content of not more than 250 g/L.
 9. Quick-Dry Primers, Sealers, and Undercoaters: VOC content of not more than 200 g/L.
 10. Specialty Primers, Sealers, and Undercoaters: VOC content of not more than 350 g/L.
 11. Stains: VOC content of not more than 250 g/L.
 12. Wood Preservatives: VOC content of not more than 350 g/L.
- C. Colors: Provide color selections made by the Architect. Allow for up to 5 different color selections.

BURBANK BRANCH RENOVATIONS, PORTLAND PUBLIC LIBRARY

2.3 PRIMERS/SEALERS

A. Alkali-Resistant Primer/Sealer:

1. Cal: ProPrime Undercoater Primer-Sealer 54500.
2. Glidden Professional: 3210-1200 Gripper Interior/Exterior Primer Sealer. (100 g/L)
3. Moore: Super Spec Latex Enamel Undercoater & Primer Sealer #253.
4. PPG: 4-603 Perma-Crete Interior/Exterior Acrylic Latex Alkali Resistant Primer. (88 g/L)
5. S-W: Prep Rite Masonry Primer B28W200 Series.

B. Low-VOC Latex Primer/Sealer:

1. Cal: Envirotech Zero VOC Interior Latex Primer/Sealer, 64600.
2. Moore: Pristine Eco Spec Interior Latex Primer Sealer, No. 231
3. Glidden Professional: 9116-1200 LifeMaster No VOC Interior Primer. (0 g/L)
4. PPG: Pure Performance Interior Latex Primer, 9-900 Series. (0 g/L)
5. SW: ProMar 200 Zero VOC Interior Latex Primer B28W02600 Series. (0 g/L)]

C. High-Build Primer/Sealer:

1. Cal: Hide-A-Spray, 91-20. (VOC 76 g/L)
2. Glidden Professional: 1040-1200, High Build Surfacer Interior Primer Sealer. (100g/L)
3. PPG: 6-1 Speedhide Interior MaxBuild High Build Surfacer. (<50 g/L)
4. SW: PrepRite High Build Interior Latex Primer/Surfacer B28W601 (VOC 74 g/L).
5. Moore: Super Spec Satin-Fil 172 (VOC 31g/L)

2.4 METAL PRIMERS

A. Rust-Inhibitive Primer (Water Based):

1. Cal: Rust Stop DTM 100% Acrylic Semi-Gloss, 10XX.
2. Devoe Coatings: 4020-1000 Devflex 4020PF DTM Primer & Flat Finish. (91 g/L)
3. Moore: IMC Acrylic Metal Primer M04. (51 g/L)
4. Pittsburgh Paints; 90-712 Pitt-Tech One Pack Interior/Exterior Primer Finish DTM Industrial Enamel. (123 g/L)
5. S-W: IMC Pro-Cryl Universal Primer, B66-310 Series. (100 g/L)

2.5 WOOD PRIMERS

A. Latex-Based Wood Primer:

1. Cal: ASAP "30" 50300.
2. Glidden Professional: 3210-1200 Gripper Interior/Exterior Primer Sealer. (100 g/L)
3. Moore: Super Spec Latex Enamel Undercoater & Primer Sealer #253.
4. PPG: Seal Grip Interior Primer/Finish, 17-951. (45 g/L)
5. S-W: PrepRite Classic Latex Primer B28W101 Series.

BURBANK BRANCH RENOVATIONS, PORTLAND PUBLIC LIBRARY

- B. Wood-Knot Sealer: Sealer recommended in writing by topcoat manufacturer for use in paint systems indicated.

2.6 LATEX PAINTS

A. Low-VOC Latex (Flat):

1. California Paints: Rust Stop DTM 100% Acrylic Semi-Gloss, 633XX.
2. Glidden Professional: 1209-XXXXN Ultra-hide No VOC Interior Flat Paint (0 g/L)
3. Moore: Eco Spec Interior Latex Flat, No. 219.
4. PPG: 6-4110XI Series, Speedhide zero Interior Zero VOC Interior Flat Latex. (0 g/L)
5. SW: ProMar 200 Zero VOC Interior Latex Flat B30-2600 Series. (0 g/L)]

B. Low-VOC Latex (Low Luster):

1. California Paints: Rust Stop DTM 100% Acrylic Semi-Gloss, 631XX.
2. Glidden Professional: 1411-XXXX Ultra-hide No VOC Interior Eggshell Paint (0 g/L)
3. Moore: Pristine Eco Spec Interior Latex Eggshell, No. 223
4. PPG: 6-4310XI Series, Speedhide zero Interior Zero VOC Latex Eggshell Interior. (0 g/L)
5. SW: ProMar 200 Zero VOC Interior Latex Eg-Shell B20-2600 Series. (0 g/L)]

C. Low-VOC Latex (Semi-gloss):

1. California Paints: Rust Stop DTM 100% Acrylic Semi-Gloss, 663XX.
2. Glidden Professional: 1415-XXXXN Ultra-hide No VOC Interior Semi-Gloss Paint (0 g/L)
3. Moore: Pristine Acrylic Semi-Gloss, No. 214
4. PPG: 6-4510XI Series, Speedhide zero Interior Zero VOC Latex Semi-Gloss. (0 g/L)
5. SW: ProMar 200 Zero VOC Interior Latex Semi-Gloss B31-2600 Series. (0 g/L)]

PART 3 - EXECUTION

3.1 EXAMINATION

- A. Examine substrates and conditions, with Applicator present, for compliance with requirements for maximum moisture content and other conditions affecting performance of work.
- B. Maximum Moisture Content of Substrates: When measured with an electronic moisture meter as follows:
 1. Wood: 15 percent.
 2. Gypsum Board: 12 percent.
 3. Plaster: 12 percent.
- C. Verify suitability of substrates, including surface conditions and compatibility with existing finishes and primers.

BURBANK BRANCH RENOVATIONS, PORTLAND PUBLIC LIBRARY

- D. Begin coating application only after unsatisfactory conditions have been corrected and surfaces are dry.
 - 1. Beginning coating application constitutes Contractor's acceptance of substrates and conditions.

3.2 PREPARATION

- A. Comply with manufacturer's written instructions applicable to substrates indicated.
- B. Remove plates, machined surfaces, and similar items already in place that are not to be painted. If removal is impractical or impossible because of size or weight of item, provide surface-applied protection before surface preparation and painting.
 - 1. After completing painting operations, use workers skilled in the trades involved to reinstall items that were removed. Remove surface-applied protection if any.
 - 2. Do not paint over labels of independent testing agencies or equipment name, identification, performance rating, or nomenclature plates.
- C. Clean substrates of substances that could impair bond of paints, including dirt, oil, grease, and incompatible paints and encapsulants.
 - 1. Remove incompatible primers and reprime substrate with compatible primers as required to produce paint systems indicated.
- D. Steel Substrates: Remove rust and loose mill scale. Clean using methods recommended in writing by paint manufacturer.
- E. Shop-Primed Steel Substrates: Clean field welds, bolted connections, and abraded areas of shop paint, and paint exposed areas with the same material as used for shop priming to comply with SSPC-PA 1 for touching up shop-primed surfaces.
- F. Galvanized-Metal Substrates: Remove grease and oil residue from galvanized sheet metal fabricated from coil stock by mechanical methods to produce clean, lightly etched surfaces that promote adhesion of subsequently applied paints. Uniformly abrade galvanized surfaces with a palm sander and 60 grit aluminum oxide so surface is free of oil and surface contaminants.
- G. Wood Substrates:
 - 1. Scrape and clean knots, and apply coat of knot sealer before applying primer.
 - 2. Sand surfaces that will be exposed to view, and dust off.
 - 3. Prime edges, ends, faces, undersides, and backsides of wood.
 - 4. After priming, fill holes and imperfections in the finish surfaces with putty or plastic wood filler. Sand smooth when dried.
- H. Gypsum Board Substrates: Do not begin paint application until finishing compound is dry and sanded smooth.
- I. Plaster Substrates: Do not begin paint application until plaster is fully cured and dry.

- J. Existing Painted Surfaces: Remove any loose paint by scraping or sanding. Sand any rough or “orange peel” or crazing areas.

3.3 APPLICATION

- A. Apply paints according to manufacturer's written instructions.
 - 1. Use applicators and techniques suited for paint and substrate indicated.
 - 2. Paint surfaces behind movable equipment and furniture same as similar exposed surfaces. Before final installation, paint surfaces behind permanently fixed equipment or furniture with prime coat only.
 - 3. Paint front and backsides of access panels, removable or hinged covers, and similar hinged items to match exposed surfaces.
 - 4. Apply an additional coat of primer on metal surfaces that have been shop primed.
- B. Tinting: Tint primer of colors such as reds, yellows, and oranges with a gray basecoat system designed to help provide color coverage.
 - 1. Do not tint prime or base coat for multi-colored finishes.
- C. If undercoats or other conditions show through topcoat, apply additional coats until cured film has a uniform paint finish, color, and appearance. Give special attention to ensure edges, corners, crevices, welds, and exposed fasteners receive a dry film thickness equivalent to that of flat surfaces. When using colors such as red, yellow or orange, an extra coat of finish may be necessary. Notify Architect when additional coats do not fix the problem.
- D. Apply paints to produce surface films without cloudiness, spotting, holidays, laps, brush marks, roller tracking, runs, sags, ropiness, or other surface imperfections. Cut in sharp lines and color breaks.
- E. Painting Fire Suppression, Plumbing, HVAC, Electrical, Communication, and Electronic Safety and Security Work:
 - 1. Paint the following work where exposed in equipment rooms: Not required.
 - 2. Paint the following work where exposed in occupied spaces:
 - a. Equipment, including panelboards.
 - b. Uninsulated metal piping.
 - c. Uninsulated plastic piping.
 - d. Pipe hangers and supports.
 - e. Metal conduit.
 - f. Plastic conduit.
 - g. Duct, equipment, and pipe insulation having cotton or canvas insulation covering or other paintable jacket material.
 - h. Interior of ductwork where visible through grilles, vents or diffusers.
 - i. Other items as directed by Architect.

BURBANK BRANCH RENOVATIONS, PORTLAND PUBLIC LIBRARY

3.4 CLEANING AND PROTECTION

- A. At end of each workday, remove rubbish, empty cans, rags, and other discarded materials from Project site.
- B. After completing paint application, clean spattered surfaces. Remove spattered paints by washing, scraping, or other methods. Do not scratch or damage adjacent finished surfaces.
- C. Protect work of other trades against damage from paint application. Correct damage to work of other trades by cleaning, repairing, replacing, and refinishing, as approved by Architect, and leave in an undamaged condition.
- D. At completion of construction activities of other trades, touch up and restore damaged or defaced painted surfaces.

3.5 INTERIOR PAINTING SCHEDULE

- A. VOC Compliance, General: Provide the manufacturers' formulations for the products specified below that comply with the VOC requirements for the State of Maine Department of Environmental Protection in paragraph 2.2 of this Section.
- B. Steel and Galvanized Metal Substrates: Including, but not limited to steel doors and frames, handrails, wood door glass lite kits, metal fabrications; see Division 05 Section "Metal Fabrications", and miscellaneous metal items.
 - 1. Low-VOC Latex Over DTM Primer System:
 - a. Prime Coat: DTM anticorrosive metal primer.
 - b. Intermediate Coat: Low-VOC latex paint matching topcoat.
 - c. Topcoat: Low-VOC latex semi-gloss paint.
- C. Wood Substrates: Including wood trim [and **windows**].
 - 1. Low-VOC Latex System:
 - a. Prime Coat: Interior latex-based wood primer.
 - b. Intermediate Coat: Low-VOC latex paint matching topcoat.
 - c. Topcoat: Low-VOC latex (semigloss) paint.
- D. Gypsum Board Substrates:
 - 1. Low-VOC Latex System:
 - a. Prime Coat: Low-VOC latex primer/sealer.
 - b. Intermediate Coat: Low-VOC latex paint matching topcoat.
 - c. Topcoat: Low-VOC latex (flat) paint on ceilings, (eggshell) paint on walls.
- E. Fiberglass-Faced Gypsum Board Substrates:
 - 1. Low-VOC Latex System:

BURBANK BRANCH RENOVATIONS, PORTLAND PUBLIC LIBRARY

- a. Prime Coat: High-Build Primer/Sealer.
- b. Intermediate Coat: Low-VOC latex paint matching topcoat.
- c. Topcoat: Low-VOC latex (eggshell) paint.

F. Plaster Substrates:

1. Low-VOC Latex System:

- a. Prime Coat: Alkali-resistant primer/sealer.
- b. Intermediate Coat: Low-VOC latex paint matching topcoat.
- c. Topcoat: Low-VOC latex (flat) paint on ceilings, (eggshell) paint on walls.

END OF SECTION 099123

SECTION 102600 - WALL AND DOOR PROTECTION

PART 1 - GENERAL

1.1 RELATED DOCUMENTS

- A. Drawings and general provisions of the Contract, including General and Supplementary Conditions and Division 01 Specification Sections, apply to this Section.

1.2 SUMMARY

- A. Section Includes:
 - 1. Corner guards.

1.3 ACTION SUBMITTALS

- A. Product Data: For each type of product.
 - 1. Include construction details, material descriptions, impact strength, dimensions of individual components and profiles, and finishes.

1.4 DELIVERY, STORAGE, AND HANDLING

- A. Store wall and door protection in original undamaged packages and containers inside well-ventilated area protected from weather, moisture, soiling, extreme temperatures, and humidity.
 - 1. Maintain room temperature within storage area at not less than 70 deg F during the period plastic materials are stored.

PART 2 - PRODUCTS

2.1 MANUFACTURERS

- A. Source Limitations: Obtain wall- and door-protection products from single source from single manufacturer.

2.2 CORNER GUARDS

- A. Surface-Mounted, Metal Corner Guards): Fabricated from one-piece, formed or extruded metal with formed edges; with 90-degree turn to match wall condition.

BURBANK BRANCH RENOVATIONS, PORTLAND PUBLIC LIBRARY

1. Basis-of-Design Product: Subject to compliance with requirements, provide Stainless Steel surface Mount Corner Guard by IPC or comparable product by one of the following:
 - a. Balco, Inc.
 - b. Construction Specialties, Inc.
 - c. Pawling.
 - d. Tepromark International, Inc.
2. Material: Stainless steel, Type 304.
 - a. Thickness: Minimum 0.0500 inch.
 - b. Finish: Directional satin, No. 4.
 - c. Height: 48 inches.
3. Wing Size: Nominal 2 by 2 inches.
4. Corner Radius: 1/8 inch.
5. Mounting: Flat-head, countersunk screws through factory-drilled mounting holes.

2.3 MATERIALS

- A. Fasteners: Aluminum, nonmagnetic stainless-steel, or other noncorrosive metal screws, bolts, and other fasteners compatible with items being fastened. Use security-type fasteners where exposed to view.

2.4 FABRICATION

- A. Fabricate wall and door protection according to requirements indicated for design, performance, dimensions, and member sizes, including thicknesses of components.
- B. Factory Assembly: Assemble components in factory to greatest extent possible to minimize field assembly. Disassemble only as necessary for shipping and handling.
- C. Quality: Fabricate components with uniformly tight seams and joints and with exposed edges rolled. Provide surfaces free of wrinkles, chips, dents, uneven coloration, and other imperfections. Fabricate members and fittings to produce flush, smooth, and rigid hairline joints.

2.5 FINISHES

- A. Protect finishes on exposed surfaces from damage by applying a strippable, temporary protective covering before shipping.
- B. Appearance of Finished Work: Noticeable variations in same piece are not acceptable. Variations in appearance of adjoining components are acceptable if they are within the range of approved Samples and are assembled or installed to minimize contrast.

BURBANK BRANCH RENOVATIONS, PORTLAND PUBLIC LIBRARY

PART 3 - EXECUTION

3.1 INSTALLATION

- A. Installation Quality: Install wall protection according to manufacturer's written instructions, level, plumb, and true to line without distortions. Do not use materials with chips, cracks, voids, stains, or other defects that might be visible in the finished Work.

3.2 CLEANING

- A. Immediately after completion of installation, clean plastic covers and accessories using a standard ammonia-based household cleaning agent.

END OF SECTION 102600

SECTION 142416 – LU/LA ELEVATOR

PART 1 - GENERAL

1.1 RELATED DOCUMENTS

- A. Drawings and general provisions of the Contract, including General and Supplementary Conditions and other Division 01 Specification Sections, apply to this Section.

1.2 SUMMARY

A. Section Includes:

- 1. Limited Use/Limited Application (LU/LA) Hydraulic Passenger Elevator.
- 2. The scope of this section of work is the provision and installation of a LU/LA Elevator, all the necessary equipment required to fully complete the installation, and coordinate between the other associated work required by other trades. The equipment specifications are based on the Symmetry Elevating Solutions Elevation LU/LA product design.

B. Related Requirements:

- 1. Section 015000 "Temporary Facilities and Controls" for limitations and procedures governing temporary use of Owner's facilities.

1.3 REGULATORY REQUIREMENTS

A. Provide passenger elevator in compliance with:

- 1. ASME A17.1 - Safety Code for Elevators and Escalators.
- 2. ASME A17.5 - Elevator and Escalator Electrical Equipment.
- 3. Requirements of Americans with Disabilities Act.

1.4 SUBMITTALS

A. Product Information:

- 1. Submit manufacturer's installation instructions including preparation, and equipment handling requirements.
- 2. Show maximum and average power necessity.

B. Shop Drawings:

- 1. Show typical details of assembly, erection and anchorage.
- 2. Include wiring diagrams for power, control, and signal systems.
- 3. Show complete layout and location of equipment, including required clearances and coordination with shaftway

BURBANK BRANCH RENOVATIONS, PORTLAND PUBLIC LIBRARY

1.5 QUALITY ASSURANCE

- A. Manufacturer: Company shall contain personnel with not less than ten (10) years of experience in the design and fabrication of LU/LA elevators.
- B. Technical Services: Manufacturer and authorized dealer shall work with architects, engineers and contractors to adapt the LU/LA elevator to the design and structural requirements of the building, site, and code requirements.
- C. Unit shall be tested in the factory before shipment. Elevator equipment shall meet or exceed the National and Local standards.
- D. All load ratings and safety factors shall meet or exceed those specified by all governing agencies and be certified by an independent professional engineer.
- E. Installer Qualifications: Factory trained and licensed to install equipment of this scope, with evidence of experience with specified equipment. Installing company shall have qualified people available to ensure fulfillment of maintenance and callback service.

1.6 DELIVERY, STORAGE, AND HANDLING

- A. Products stored in manufacturer's unopened packaging until ready for installation.
- B. Components stored off the ground in a dry covered space, protected from weather conditions.

1.7 PROJECT CONDITIONS

- A. LU/LA Elevator not to be used for hoisting materials or personnel during construction.

1.8 WARRANTY

- A. Unit shall have a THREE (3) year limited parts warranty covering replacement of defective parts of the basic unit, including all electrical and drive system components, at no cost. Labor costs required to replace parts is not included. Preventative maintenance agreement required.

1.9 MAINTENANCE SERVICE

- A. Maintenance of a LU/LA elevator shall consist of regular cleaning, inspection, and adjustment of the unit at intervals not longer than every six (6) months. Rule 10.2.1 of ASME A17.1 requires all LU/LA elevators to be inspected every six (6) months. Provide Maintenance contract for one (1) year.
- B. Maintenance of the LU/LA elevator until shall consist of regular cleaning, inspection, adjustment, lubrication and examination not less than every six (6) months. Repair or replace parts when necessary. Rule 10.2.1 of ASME A17.1 requires all LU/LA elevators to be inspected every six (6) months. Proved emergency call back service for this maintenance period.
- C. Maintenance work to be performed by factory trained and licensed technician.

PART 2 - PRODUCTS

2.1 MANUFACTURER

- A. Acceptable Manufacturer: Symmetry Elevating Solutions.
- B. Approved Installer: All-Ways Accessible, Inc., 128 Hall Street, Suite F, Concord, NH 03301 800-684-0270.

2.2 LIMITED USE/LIMITED APPLICATION (LU/LA) ELEVATOR

A. Symmetry Elevating Solutions LU/LA Elevator:

- 1. Capacity: 1400 lbs.
- 2. Car Size: Maximum of 42 by 60 inches.
- 3. Platform Configuration: Single opening, rail-right.
- 4. Travel: 9 foot, 4 inches.
- 5. Stops: Two.
- 6. Speed: 30 feet/minute.
- 7. Pit Depth: As indicated on the drawings.
- 8. Overhead Clearance: Total overhead clearance required is 108" (existing construction with alternate top car clearance device), 132" (new construction) above the upper landing level for standard height car.
- 9. Power Requirements:
 - a. 208/230 VAC, 30 Amp, Single Phase.
 - b. A Separate 115 VAC 15 Amp circuit is required for car lighting.
- 10. Hydraulic Power Unit:
 - a. The pump shall utilize a 4 HP high efficiency, low power consumption motor.
 - b. The pump, submerged motor and valve shall be pre-wired, ready for connection to the controller in the field.
 - c. Acceleration, deceleration, and leveling speed controls shall be provided in the Up and Down directions. Full speed adjustment shall be provided in the Down direction only.
 - d. Two speed operation shall be provided.
 - e. Adjustable pressure relief valves shall be provided.
 - f. Manual emergency lowering valve shall be provided.
 - g. Pressure gauges and pressure gauge isolation valves shall be provided.
 - h. Manual valve isolation between pump unit and jack shall be provided.
 - i. Negative pressure switch shall be provided.
 - j. Testing: Shall be factory tested prior to shipment.
 - k. Muffler shall be provided for vibration & noise damping during elevator operation.
- 11. Cylinder:
 - a. Construction: Steel pipe with cylinder head having an internal guide ring and self-adjusting, self-lubricating packing.

BURBANK BRANCH RENOVATIONS, PORTLAND PUBLIC LIBRARY

- b. Safety Valve: Cylinder shall be equipped with an overspeed safety valve to prevent uncontrolled car descent.
12. Plunger:
- a. Construction: Shall be machined steel shaft equipped with a stop, electrically welded to bottom end, to prevent plunger from leaving shaft cylinder.
 - b. Diameter: 90mm.
13. Components:
- a. Suspension system: 1:2 system using (2) 3/8" - 7×19 Galvanized aircraft cables integrated with rams header sheave mounted to the plunger.
 - b. Guide Rail: Shall consist of two 8 lb. tee rails. Provide brackets to hold rail assembly to walls. Rail shall be furnished with steel splice plates and hardware.
 - c. Car Frame: Shall be equipped with non-metallic faced roller guide wheels.
 - d. Leveling Device: Provide Hall-effect Sensor based device integrated with tapeless Selector Package to maintain car within 1/4" of the landing.
14. Controls:
- a. Selective collective PLC-based controller (Programmable Logic Controller) with Hardware Circuit Monitoring.
 - b. "Self Diagnostic System" utilizing diagnostic codes displayed in car to provide information in the event the elevator will not operate. All required redundancies are monitored by the PLC and verified by a hardware monitoring system in compliance with A17.1 2.26.9.3.
 - c. Visual & Audible directional indicators passing chime.
 - d. All Elevator Electrical Systems shall conform to ASME A17.5.
15. Car Doors:
- a. Size 3'0" × 6'8".
 - b. Closed Loop Linear 2 speed Door Operator.
 - c. Car Door Equipped with a full height safety light screen.
 - d. Car Door with electric switch to ensure the car door is closed prior to the operation of the elevator.
16. Hoistway Doors:
- a. Size: Minimum Dimensions 3'0" W x 6'8" H.
 - b. Type and installation of doors and frames must comply with ASME A17.1, all local codes and manufacturer's layout drawings.
 - c. Locking Device: Door shall have a concealed locking device, interlocked with the car operation, to interrupt electrical power when the door is not securely closed and a car is not at the landing zone.
17. Safety Features:

- a. Slack cable protection: Provide an electronically monitored and mechanically actuated hardened steel device that stops and sustains the car in the event of breakage or slackening of cables.
- b. Terminal stopping Device: Shall be provided at the top and bottom of the car travel.
- c. Provide a platform toe guard at the car entrance.
- d. Battery powered emergency operation system:
 - 1) Powers a light in the car.
 - 2) Powers an emergency alarm system.
 - 3) Powers a system to allow car to stop at the next available floor, then run down to the bottom floor stopping at each floor along the way. Door cycles at each landing.
 - 4) The batteries shall be re-chargeable type complete with an automatic re-charging system.
- e. Emergency operation of Car Lights with half illumination level.
- f. 1/2" x 2" Flat Handrail #4 SS with returned ends.
- g. Overspeed valve.
- h. Final limit switch.
- i. Low oil protection timer circuit.

2.3 CAB DESIGN

A. Cab Design:

1. Interior Walls: Metal Panel (Standard).
2. Interior Wall Finish (Standard).
3. Car Doors: Ivory (Standard).
4. Custom Cab Options: None.
5. Fire Service Options: None.
6. Floor: Prepared 1/4" flooring by others. (Carpet)
7. Lighting:
 - a. 115 VAC, single phase, 15 Amps.
 - b. Failure of one lamp shall not cause the remaining lamps to extinguish.
 - c. Lights shall turn on automatically when the elevator door is opened and stay on while the elevator is in use. Lights will automatically turn off after a predetermined time interval when the elevator is not in use.
 - d. Overhead low power consumption LED light fixtures.
 - e. Color: Black.

B. Call Stations:

1. Control Panel:
 - a. One momentary pressure illuminated button for each landing.
 - b. Keyed in car stop switch and alarm button.
 - c. Door open & close buttons.
 - d. Hands free ADA phone.

BURBANK BRANCH RENOVATIONS, PORTLAND PUBLIC LIBRARY

- e. Digital position indicator.
 - f. Finish: Stainless steel.
2. Hall Call Stations: One momentary pressure illuminated button for selecting the users desired direction of travel per landing.

PART 3 - EXECUTION

3.1 EXAMINATION

- A. Do not begin installation until preliminary work including hoistway, landings and machine space has been properly prepared.
- B. Verify shaft and machine space are of correct size and within tolerance.
- C. Verify required landings and openings are of correct size and within tolerances.
- D. Verify hoistway shaft and machine room temperature is designed to have maintainable temperatures between 50°F–90°F.
- E. Verify machine room, when required, is provided with lighting, light switch, convenience outlets and meets the clear space requirements of ASME A17.1 & NEC.
- F. Verify hoistway and openings are of correct size and within tolerance.
- G. Verify electrical power is available and of correct characteristics.
- H. If preliminary work is the responsibility of another installer, notify Architect of unsatisfactory preparation before proceeding.

3.2 PREPARTION

- A. Clean surfaces thoroughly prior to installation..
- B. Prepare surfaces using the methods recommended by the manufacturer for achieving the optimum performance of LU/LA elevator.

3.3 INSTALLATION

- A. Unit shall be installed and operated in accordance with the ICC/A117.1, NAEC and ASME A17.1 Guidelines.
- B. A dedicated electrical supply provided to the disconnect shall be capable of supplying sufficient power.
- C. GC to coordinate “work by others” with elevator contractor.

BURBANK BRANCH RENOVATIONS, PORTLAND PUBLIC LIBRARY

- D. The installation of the LU/LA elevator shall be made in accordance with approved plans and specifications and to the manufacturer's installation instructions.
- E. Startup and test unit in accordance with manufacturer's instructions.

3.4 FIELD QUALITY CONTROL

- A. Perform tests in compliance with ASME A17.1 as required by authorities having jurisdiction.
- B. Load the LU/LA elevator to rated capacity and test for several cycles to insure proper operation. No mechanical failures shall occur and no wear that would affect the reliability of the unit shall be detected.
- C. Schedule tests with agencies and Architect, Owner, and Contractor present.

3.5 ADJUSTING

- A. Adjust for smooth acceleration and deceleration.
- B. Adjust automatic floor leveling feature at each floor to provide stopping zone of 1/4".
- C. Adjust door operation.

3.6 PROTECTION

- A. Protect installed products until completion of project.
- B. Touch-up, repair or replace damaged products before Substantial Completion.
- C. Clean unit prior to final inspection.

END OF SECTION 011000



COOK

GC



MARK: EF-3
PROJECT: 1428 Portland Library - Burbank
DATE: 2/3/2015

DRAWING NOT AVAILABLE

Performance

Qty	Catalog Number	Flow (CFM)	SP (inwc)	Nominal RPM	Input Watts
1	GC-146	105	.100	900	36

Altitude (ft): 0 Temperature (F): 70

Motor Information

Volts/Ph/Hz	Nameplate Amps
115/1/60	.313

Sound Data Inlet Sound Power by Octave Band

1	2	3	4	5	6	7	8	LwA	dBA	Sones	HVISONes
44	50	50	48	42	35	30	20	48	34	1.7	1.2

Accessories:

- WHITE PLASTIC GRILLE
- 100 SERIES DAMPER

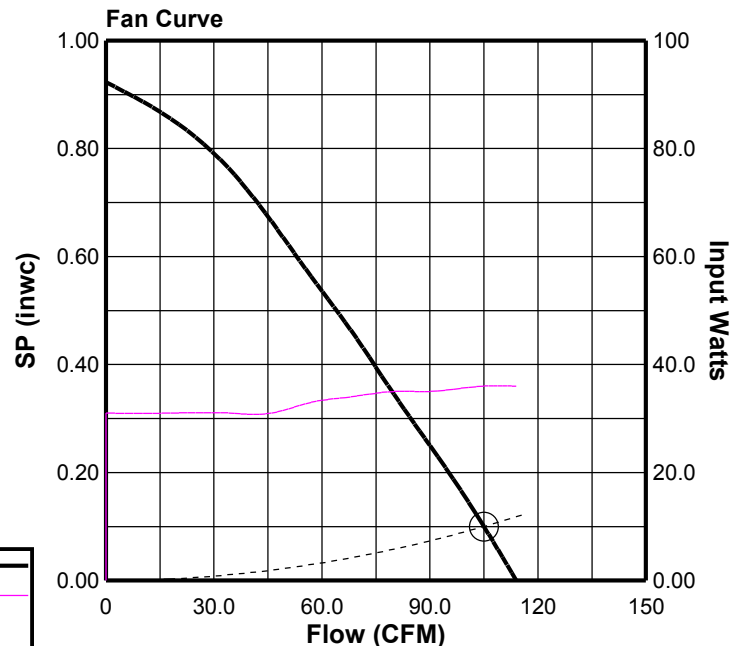



COOK

PROJECT: 1428 Portland Library - Burbank

DATE: 2/3/2015

GEMINI

PLASTIC GRILLE

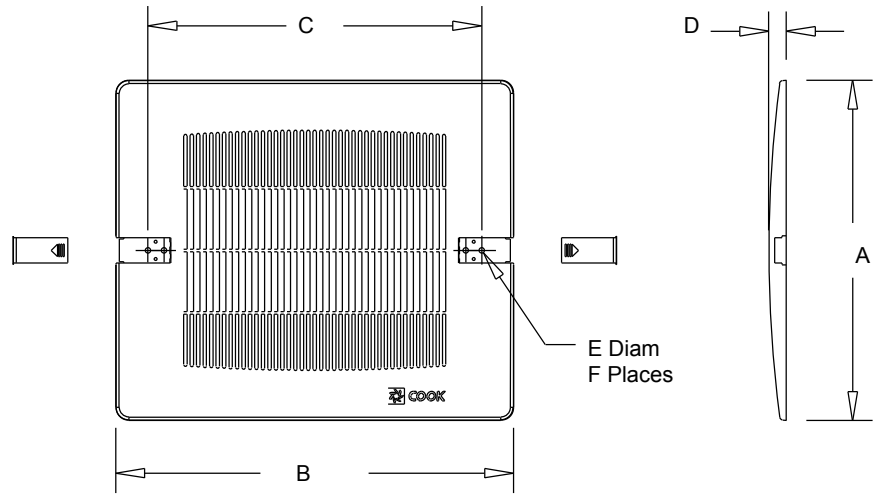

Dimensions (inches)

Mark	Qty	Description	A	B	C	D	E Diam	F Places
EF-3	1	WHITE PLASTIC GRILLE	13-1/4	15-1/2	13	1/4	1/4	4

Heavy Duty Commercial Ceiling Fans

PROJECT
DATE
SHEET OF
ENGINEER
ARCHITECT
CONTRACTOR
SUBMITTED BY

NOTE: All measurements are calculated from ceiling or beam line with "J" hook mounted securely in center of 1/2" deep conduit box and downrod supplied on rubber roller (See illustration).

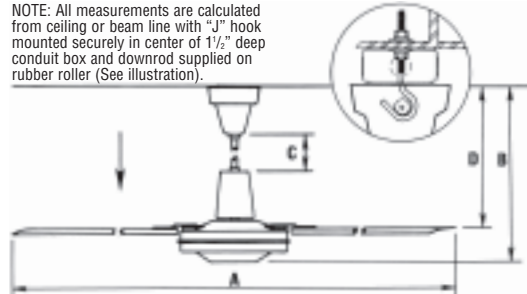

CEILING FAN DIMENSIONS* (mm)				
MODELS SUPPLIED WITH 8" & 24" DOWNROD				
MODEL SERIES	A	B	C	D
36201***	36"	33 1/2"	19"	30 1/2"
48201***	48"	33 1/2"	19"	30 1/2"
56001LC***	56"	33 1/2"	19"	30 1/2"

* Allow for 1/2" variance in "J" hook depth.
*** Note for 8" downrod subtract 13" from measurement scale "C".



Ceiling Fans to be furnished as specified, Leading Edge. Fans to be U.L. listed Standard 507 with matching U.L. listed solid state controls. All motors to be direct-drive permanent split capacitor type, with permanently sealed ball bearings. All motors to have built in, self-resetting (internal) thermal overload protector TI9700.

All fans to have factory installed Secondary Support Cable Assembly connected to motor shaft, with minimum 6 feet galvanized cable 1/8" 7x7 with rated breaking strength of 1700 lbs. and must comply with CSA std. C22.2 Sept. 1986.

Fan blades to be straight with rolled edge design for maximum efficiency. Note: Fans installed with blade height less than 10' from floor must have rolled edge blades minimum 3/8" thick in compliance with U.L. 507.

Fans to be labeled in accordance with U.L. 507 "Mounted blade height to floor of 7 feet acceptable".

Fans used with motor speed controls must be labeled in accordance with U.L. 507 "Suitable for use with solid state motor speed controls".

Model 56001LC is cULus listed

Factory supplied accessories to include:

- A) Solid state motor speed controls (U.L. listed)
- B) Special length downrods
- C) Totally enclosed impact resistant fan guard
- D) Tilted canopy cover
- E) Outdoor location installation kit

SCHEDULE

ITEM	QTY.	MARK	MODEL NUMBER	BLADE SWEEP	CFM	AREA COVERAGE	RPM	VOLTS	AMPS	ACCESSORIES	REMARKS



Heavy Duty Commercial Ceiling Fans

NOTE: All measurements are calculated from ceiling or beam line with "J" hook mounted securely in center of 1/2" deep conduit box and downrod supplied on rubber roller (See illustration).

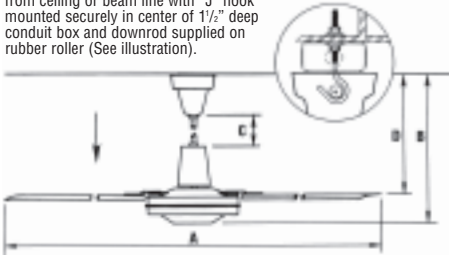

HEAVY DUTY COMMERCIAL MODELS

MODEL NUMBER	BLADE SWEEP	COLOR	VOLTS	CYCLE	FULL LOAD AMPS	FULL LOAD WATTS	RPM	MAX CFM†	AREA COVER-AGE PER FAN††	WEIGHT
36201	36"	WHT	120	50/60	.65	75	395	12,500	1600 sq.ft.	20 lbs
48201	48"	WHT	120	50/60	.85	86	315	21,000	2025 sq.ft.	22 lbs
56001LC	56"	WHT	120	50/60	1.0	110	265	25,500	3025 sq.ft.	24 lbs

ACCESSORIES & MISCELLANEOUS ITEMS

MODEL NUMBER	ITEM
28001	FAN GUARD 62" DIAMETER FOR 56" FANS ◆
28002	FAN GUARD 52" DIAMETER FOR COMMERCIAL 36" AND 48" FAN ONLY ◆
99994	TILTED CANOPY COVER
99990	DOWNRODS - 8", 12", 24", 30", 36", 48" (FOR LONGER SIZES - CONSULT FACTORY)

Fan Guards ship via UPS ◆

Custom models available. Consult with factory for information and specifications.

OPTIONAL SOLID STATE MOTOR SPEED CONTROLS

MODEL NUMBER	VOLTS	AMPS	CONTROLS	CONTROLS	CONTROLS
			36"/120 3620-1 UNITS	48"/120 4820-1 UNITS	56"/120 56001LC UNITS
12003	120	3	3	2	2
12006	120	6	7	5	5
12008	120	8	10	6	6
12012	120	12	12	10	10

NOISELESS MECHANICAL CONTROL

12001N	120	1	1	1	For use with 48" and 56" models only.
12005N	120	5	2	2	

3 YEAR WARRANTY REGISTRATION AGAINST MANUFACTURERS DEFECTS IS INCLUDED WITH EACH FAN.

† Effective amount of air volume moved past a plane 20ft. from fan, industry test. All specifications subject to change and improvement.

†† Area coverage rated for heat destratification at 20' blade mounting height.

SUBMITTAL DATA: MSY-GE15NA-8 & MUY-GE15NA2

15,000 BTU/H WALL-MOUNTED AIR-CONDITIONING SYSTEMS

Job Name:

System Reference:

Date:



Indoor Unit: MSY-GE15NA-8

 Wireless Remote
Controller

Outdoor Unit: MUY-GE15NA2

GENERAL FEATURES

- Wall-mounted indoor unit
- Standard Hybrid Catechin Prefilter is included with indoor unit
- Quiet operation
- Auto fan speed control: Quiet, Low, Medium, High, and Super High
- Hand-held Wireless Remote Controller
- Indoor unit powered from outdoor unit using A-Control
- Auto restart following a power outage
- Anti-allergy Enzyme Filter
- Limited warranty: five years parts and seven years compressor

ACCESSORIES

Outdoor Unit

- Outdoor Mounting Pad (ULTRILITE1)
- Drain Pan Heater (MAC-640BH-U)
- 3-1/4" Mounting Base [Pair] (DSD-400P)
- Drain Pan Socket (MAC-860DS)
- Air Outlet Guide (MAC-889SG)
- Wall Mounting Bracket (CWMB1)

Indoor Unit

- BlueDiamond MaxiBlue Condensate Pump (X87-721, 230V)
- Sauermann Condensate Pump (SI30-230, 230V)
- Anit-Allergy Enzyme Filter (MAC-408FT-E)
- Platinum Catalyst Deodorizing Filter (MAC-308FT-E)
- Drain Pan Level Sensor (DPLS1)

Controller Options

- Wireless Wall-mounted Remote Controller Kit (MHK1)*
 - Portable Central Controller (MCCH1)*
 - Outdoor Air Sensor (MOS1)*
 - Wired Wall-mounted Controller (PAR-31MAA requires MAC-333IF)*
 - Simple MA Remote Controller (PAC-YT53CRAU requires MAC-333IF)*
- *See Submittal for information on each option.
- System Control Interface (MAC-333IF)

SPECIFICATIONS

Cooling *1

Rated Capacity.....	14,000 Btu/h
Capacity Range.....	3,100 - 18,200 Btu/h
Rated Total Input	1,080 W
Maximum Total Input	2,000 W
SEER	21.6 Btu/h/W

Rating Conditions:

*1 Cooling | Indoor: 80° F (27° C) DB / 67° F (19° C) WB

*1 Cooling | Outdoor: 95° F (35° C) DB / 75° F (24° C) WB

Electrical Requirements

Power Supply	208 / 230V, 1-Phase, 60 Hz
Breaker Size	15 A

Voltage

Indoor - Outdoor S1-S2	AC 208 / 230V
Indoor - Outdoor S2-S3	DC +/- 24V
Indoor - Remote Controller	MKH1 DC 3V PAR-31MAA DC 12V PAC-YT53CRAU DC 12V

Operating Conditions

Cooling

Indoor Intake Air Temp. (Max.)	90° F (32° C) DB / 73° F (23° C) WB
	(Min.) 67° F (19° C) DB / 57° F (14° C) WB
Outdoor Intake Air Temp. (Max.)	115° F (46° C) DB
	(Min.) 14° F (-10° C) DB

Indoor Unit

MCA.....	1.0 A
Blower Motor (ECM).....	0.76 F.L.A.
Blower Motor Output.....	30 W
Airflow (Quiet - Lo - Med - Hi - Super Hi)	
Cooling.....	205-272-335-420-533 Dry CFM 170-237-300-385-498 Wet CFM
Sound Pressure Level (Quiet - Lo - Med - Hi - Super Hi)	
Cooling.....	26-32-38-44-49 dB(A)
External Finish Color	Munsell 1.0Y 9.2/0.2
Dimension Unit	
Inches:.....	11-5/8 H x 31-7/16 W x 9-1/8 D
mm:	295 H x 798 W x 232 D
Weight Unit.....	22 lbs. / 10kg
Field Drainpipe Size O.D.....	19/32" x 15 mm

Outdoor Unit

MCA.....	12 A
Fan Motor (ECM).....	0.50 F.L.A.
Sound Pressure Level	
Cooling *1.....	49 dB(A)
External Finish Color	Munsell 3Y 7.8/1.1
External Dimensions	
Inches:.....	21-5/8 H x 31-1/2 W x 11-1/4 D
mm:	550 H x 800 W x 285 D
Weight	80 lbs. / 36kg
Refrigerant Type.....	R410A
Refrigerant Pipe	
Gas Side O.D.....	1/2" x / 12.7mm
Liquid Side O.D.....	1/4" / 6.35 mm
Refrigerant Pipe Length	
Height Difference (Max.)	40' / 12 m
Length (Max.)	65' / 20 m
Connection Method	
Indoor/Outdoor	Flared

DIMENSIONS: MSY-GE15NA-8 & MUY-GE15NA2

MSY-GE15NA-8

Unit: inch

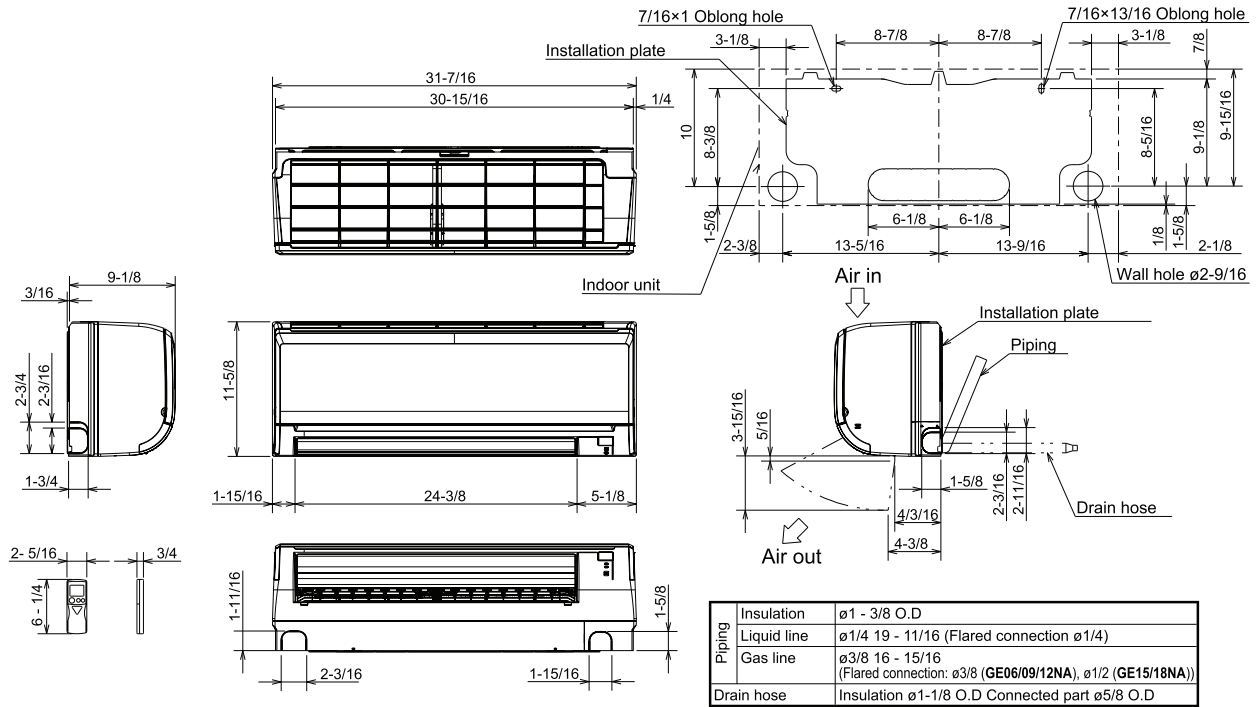

MUY-GE15NA2

Unit: inch

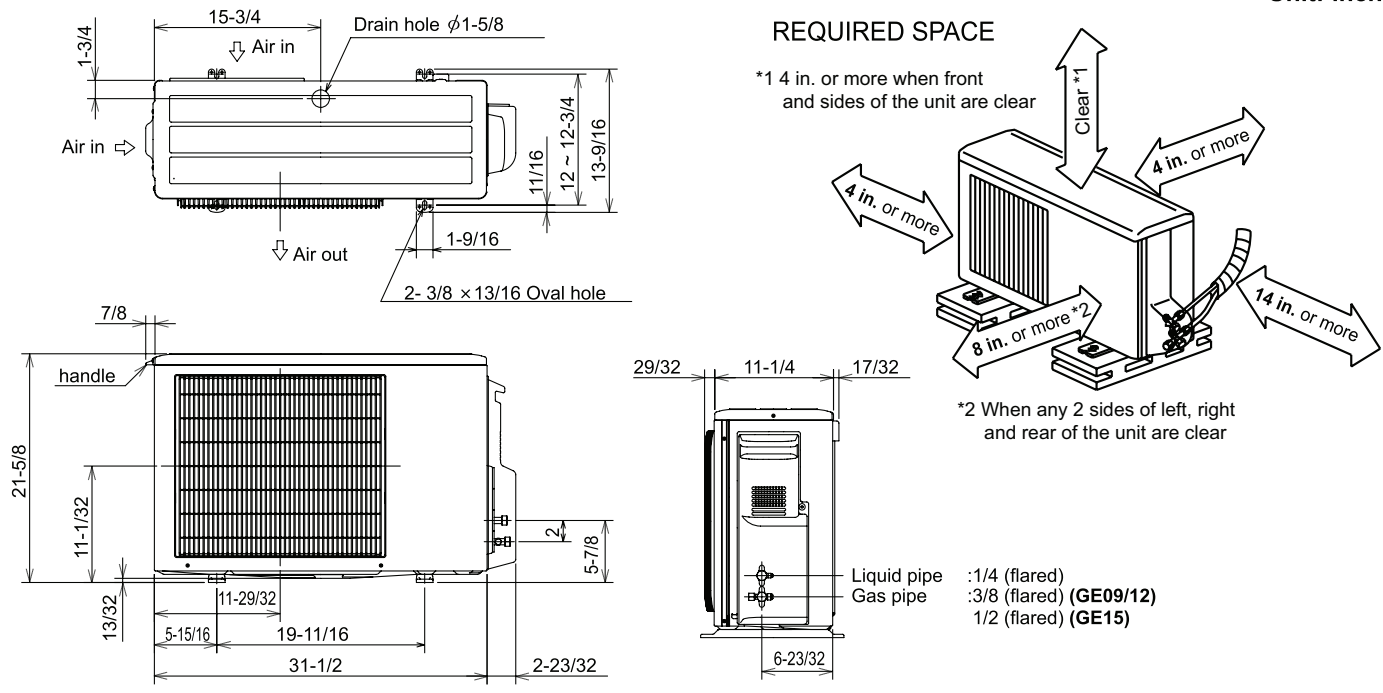

Intertek

INVERTER

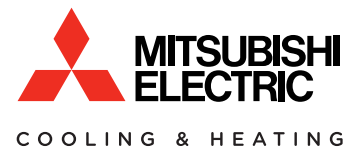

1340 Satellite Boulevard
Suwanee, GA 30024
Tel: 678-376-2900 • Fax: 800-889-9904
Toll Free: 800-433-4822
www.mehvac.com

SUBMITTAL DATA: MSY-GE09NA-8 & MUY-GE09NA2

9,000 BTU/H WALL-MOUNTED AIR-CONDITIONING SYSTEMS

Job Name:

System Reference:

Date:



Indoor Unit: MSY-GE09NA-8

 Wireless Remote
Controller

Outdoor Unit: MUY-GE09NA2

GENERAL FEATURES

- Wall-mounted indoor unit
- Standard Hybrid Catechin Prefilter is included with indoor unit
- Quiet operation
- Auto fan speed control: Quiet, Low, Medium, High, and Super High
- Hand-held Wireless Remote Controller
- Indoor unit powered from outdoor unit using A-Control
- Auto restart following a power outage
- Anti-allergy Enzyme Filter
- Limited warranty: five years parts and seven years compressor

ACCESSORIES

Outdoor Unit

- Outdoor Mounting Pad (ULTRILITE1)
- Drain Pan Heater (MAC-640BH-U)
- 3-1/4" Mounting Base [Pair] (DSD-400P)
- Drain Pan Socket (MAC-860DS)
- Air Outlet Guide (MAC-889SG)
- Wall Mounting Bracket (CWMB1)

Indoor Unit

- BlueDiamond MaxiBlue Condensate Pump (X87-721, 230V)
- Sauermann Condensate Pump (SI30-230, 230V)
- Anit-Allergy Enzyme Filter (MAC-408FT-E)
- Platinum Catalyst Deodorizing Filter (MAC-308FT-E)
- Drain Pan Level Sensor (DPLS1)

Controller Options

- Wireless Wall-mounted Remote Controller Kit (MHK1)*
 - Portable Central Controller (MCCH1)*
 - Outdoor Air Sensor (MOS1)*
 - Wired Wall-mounted Controller (PAR-31MAA requires MAC-333IF)*
 - Simple MA Remote Controller (PAC-YT53CRAU requires MAC-333IF)*
- *See Submittal for information on each option.
- System Control Interface (MAC-333IF)

SPECIFICATIONS

Cooling *1

Rated Capacity.....	9,000 Btu/h
Capacity Range.....	3,800 - 12,200 Btu/h
Rated Total Input	660 W
Maximum Total Input	1,200 W
SEER	23.2 Btu/h/W

Rating Conditions:

- *1 Cooling | Indoor: 80° F (27° C) DB / 67° F (19° C) WB
- *1 Cooling | Outdoor: 95° F (35° C) DB / 75° F (24° C) WB

Electrical Requirements

Power Supply	208 / 230V, 1-Phase, 60 Hz
Breaker Size	15 A

Voltage

Indoor - Outdoor S1-S2	AC 208 / 230V
Indoor - Outdoor S2-S3	DC +/- 24V
Indoor - Remote Controller.....	MKH1 DC 3V
	PAR-31MAA DC 12V
	PAC-YT53CRAU DC 12V

Operating Conditions

Cooling

Indoor Intake Air Temp. (Max.)	90° F (32° C) DB / 73° F (23° C) WB
	(Min.) 67° F (19° C) DB / 57° F (14° C) WB
Outdoor Intake Air Temp. (Max.)	115° F (46° C) DB
	(Min.) 14° F (-10° C) DB

Indoor Unit

MCA.....	1.0 A
Blower Motor (ECM).....	0.76 F.L.A.
Blower Motor Output.....	30 W
Airflow (Quiet - Lo - Med - Hi - Super Hi)	
Cooling	145-170-237-321-399 Dry CFM
	109-134-201-286-364 Wet CFM
Sound Pressure Level (Quiet - Lo - Med - Hi - Super Hi)	
Cooling	19-22-30-37-43 dB(A)
External Finish Color	Munsell 1.0Y 9.2/0.2
Dimension Unit	
Inches:.....	11-5/8 H x 31-7/16 W x 9-1/8 D
mm:	295 H x 798 W x 232 D
Weight Unit	22 lbs. / 10kg
Field Drainpipe Size O.D.	19/32" x 15 mm

Outdoor Unit

MCA.....	12 A
Fan Motor (ECM).....	0.50 F.L.A.
Sound Pressure Level	
Cooling *1.....	46 dB(A)
External Finish Color	Munsell 3Y 7.8/1.1
External Dimensions	
Inches:.....	21-5/8 H x 31-1/2 W x 11-1/4 D
mm:	550 H x 800 W x 285 D
Weight	66 lbs. / 30kg
Refrigerant Type	R410A
Refrigerant Pipe	
Gas Side O.D.	3/8 " / 9.52 mm
Liquid Side O.D.	1/4" / 6.35 mm
Refrigerant Pipe Length	
Height Difference (Max.)	40' / 12 m
Length (Max.)	65' / 20 m
Connection Method	
Indoor/Outdoor	Flared

DIMENSIONS: MSY-GE09NA-8 & MUY-GE09NA2

MSY-GE09NA-8

Unit: inch

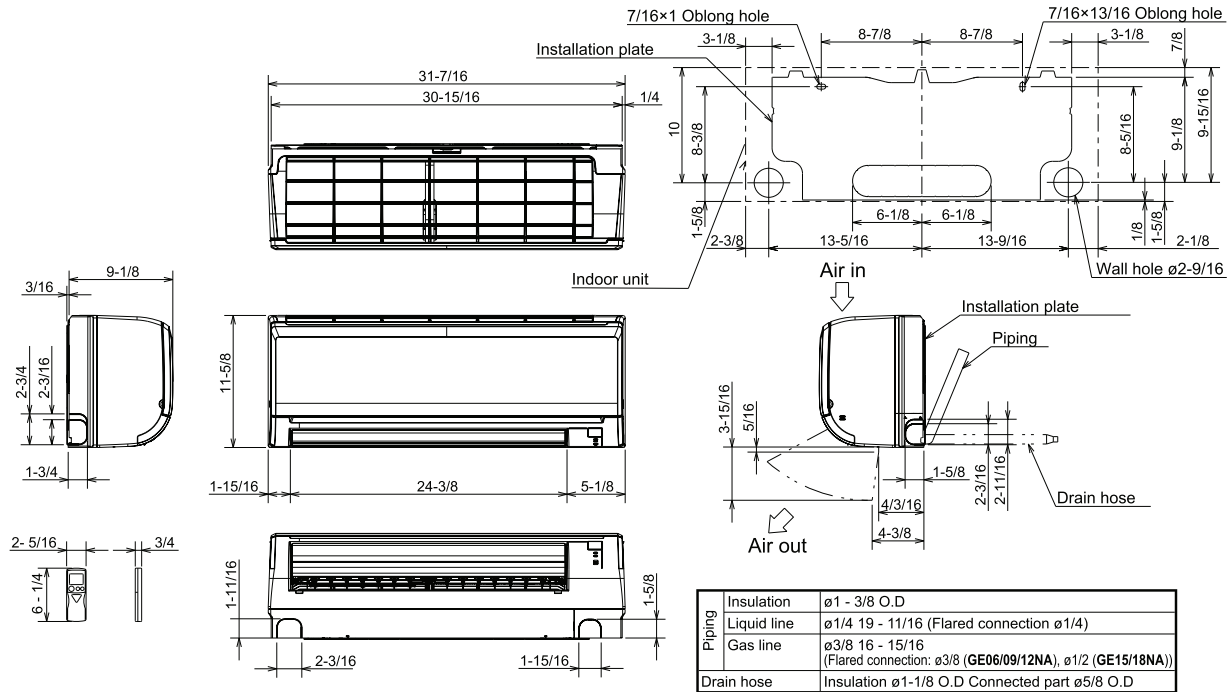

MUY-GE09NA2

Unit: inch

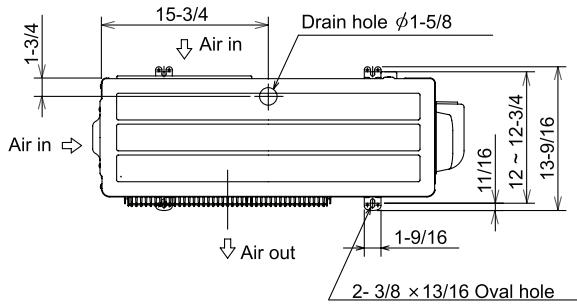

REQUIRED SPACE

*1 4 in. or more when front and sides of the unit are clear

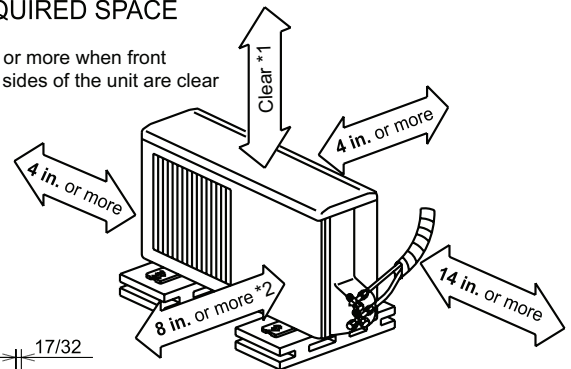

*2 When any 2 sides of left, right and rear of the unit are clear

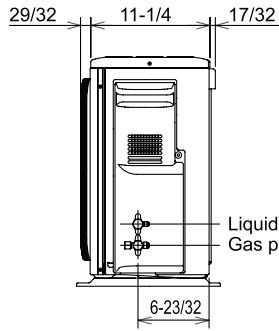
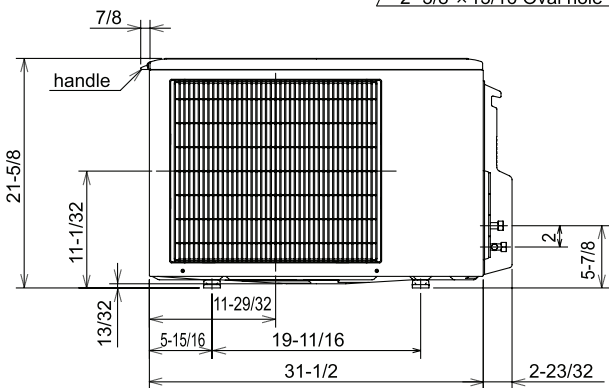

Liquid pipe :1/4 (flared)
Gas pipe :3/8 (flared) (GE09/12)
 1/2 (flared) (GE15)

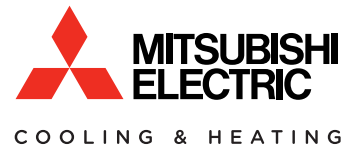

1340 Satellite Boulevard
Suwanee, GA 30024
Tele: 678-376-2900 • Fax: 800-889-9904
Toll Free: 800-433-4822
www.mehvac.com

SUBMITTAL DATA: MSY-GE24NA & MUY-GE24NA

24,000 BTU/H WALL-MOUNTED AIR-CONDITIONING SYSTEMS

Job Name:	Location:	Date:
Purchaser:	Engineer:	
Submitted to:	For <input type="checkbox"/> Reference <input type="checkbox"/> Approval <input type="checkbox"/> Construction	
System Designation:	Schedule No.:	



Indoor Unit: MSY-GE24NA



Wireless Handheld Remote Controller



Outdoor Unit: MUY-GE24NA

GENERAL FEATURES

- Wall-mounted indoor unit
- Standard Hybrid Catechin Prefilter is included with indoor unit
- Quiet operation
- Auto fan speed control: Quiet, Low, Medium, High, and Super High
- Hand-held Wireless Remote Controller
- Indoor unit powered from outdoor unit using A-Control
- Auto restart following a power outage
- Anti-allergy Enzyme Filter
- Limited warranty: five years parts and seven years compressor

ACCESSORIES

Outdoor Unit

- Three-pole Disconnect Switch (TAZ-MS303)
- Air Outlet Guide (MAC-886-SG-E)
- Mounting Base (DSD-400N)
- Mounting Pad (ULTRILITE1)
- Drain Socket Assembly (MAC-860DS)

Indoor Unit

- Condensate Pump (SI3100-230; 230V)
- Replacement Anti-allergy Enzyme Filters (MAC-2310FT-E; 2/set)

Controller Options

- Wireless Wall-mounted Remote Controller Kit (MHK1)*
- Portable Central Controller (MCCH1)*
- Outdoor Air Sensor (MOS1)*
- Wired Wall-mounted Controller (PAR-31MAA requires MAC-333IF)*
- Simple MA Remote Controller (PAC-YT53CRAU requires MAC-333IF)*

*See Submittal for information on each option.

- System Control Interface (MAC-333IF)
- Remote Temperature Sensor (M21-JKO-307)
- Lockdown Bracket for Hand-held Controller (RCMKP1CB)



DIMENSIONS: MSY-GE24NA & MUY-GE24NA

MSY-GE24NA

Unit: inch

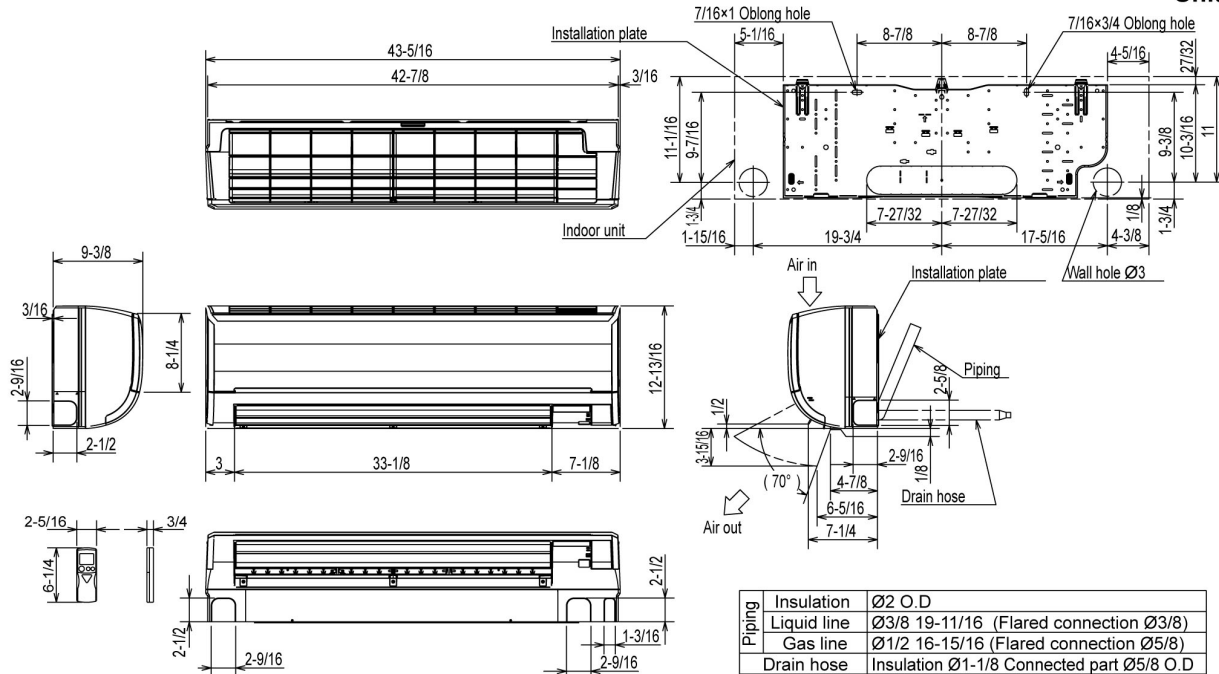

MUY-GE24NA

Unit: inch

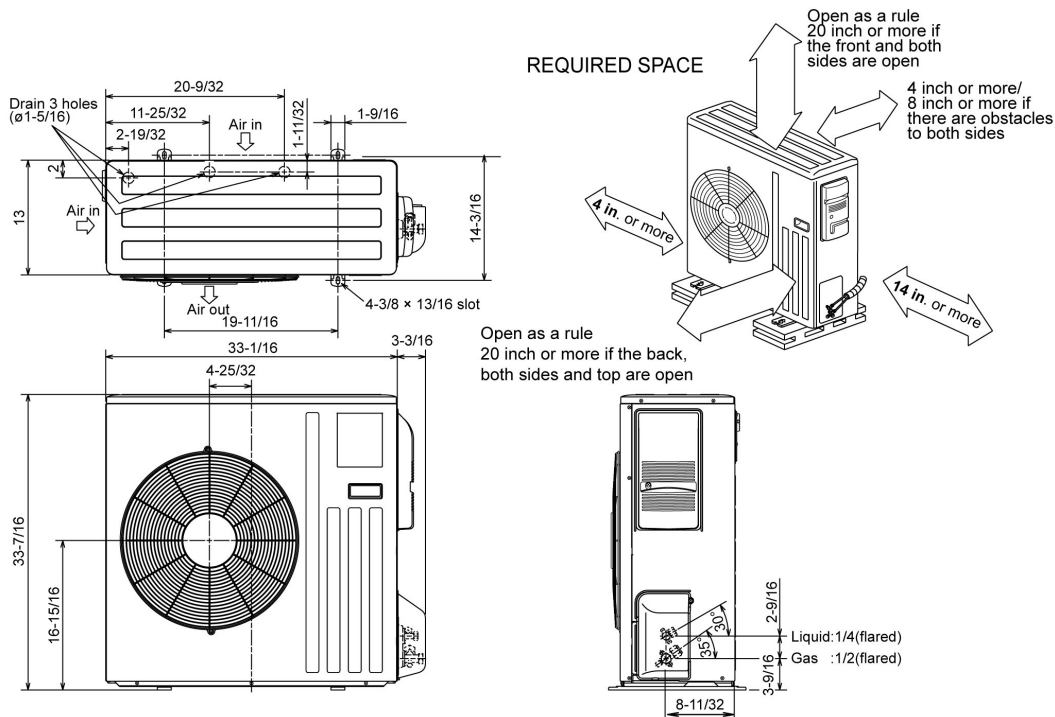

Intertek



1340 Satellite Boulevard
Suwanee, GA 30024
Tele: 678-376-2900 • Fax: 800-889-9904
Toll Free: 800-433-4822
www.mehvac.com

SUBMITTAL DATA: MSY-GE12NA-8 & MUY-GE12NA2

12,000 BTU/H WALL-MOUNTED AIR-CONDITIONING SYSTEMS

Job Name:

System Reference:

Date:



Indoor Unit: MSY-GE12NA-8

 Wireless Remote
Controller

Outdoor Unit: MUY-GE12NA2

GENERAL FEATURES

- Wall-mounted indoor unit
- Standard Hybrid Catechin Prefilter is included with indoor unit
- Quiet operation
- Auto fan speed control: Quiet, Low, Medium, High, and Super High
- Hand-held Wireless Remote Controller
- Indoor unit powered from outdoor unit using A-Control
- Auto restart following a power outage
- Anti-allergy Enzyme Filter
- Limited warranty: five years parts and seven years compressor

ACCESSORIES

Outdoor Unit

- Outdoor Mounting Pad (ULTRILITE1)
- Drain Pan Heater (MAC-640BH-U)
- 3-1/4" Mounting Base [Pair] (DSD-400P)
- Drain Pan Socket (MAC-860DS)
- Air Outlet Guide (MAC-889SG)
- Wall Mounting Bracket (CWMB1)

Indoor Unit

- BlueDiamond MaxiBlue Condensate Pump (X87-721, 230V)
- Sauermann Condensate Pump (SI30-230, 230V)
- Anit-Allergy Enzyme Filter (MAC-408FT-E)
- Platinum Catalyst Deodorizing Filter (MAC-308FT-E)
- Drain Pan Level Sensor (DPLS1)

Controller Options

- Wireless Wall-mounted Remote Controller Kit (MHK1)*
 - Portable Central Controller (MCCH1)*
 - Outdoor Air Sensor (MOS1)*
 - Wired Wall-mounted Controller (PAR-31MAA requires MAC-333IF)*
 - Simple MA Remote Controller (PAC-YT53CRAU requires MAC-333IF)*
- *See Submittal for information on each option.
- System Control Interface (MAC-333IF)

SPECIFICATIONS

Cooling *1

Rated Capacity.....	12,000 Btu/h
Capacity Range.....	3,800 - 13,600 Btu/h
Rated Total Input	960 W
Maximum Total Input	1,300 W
SEER	22.7 Btu/h/W

Rating Conditions:

- *1 Cooling | Indoor: 80° F (27° C) DB / 67° F (19° C) WB
- *1 Cooling | Outdoor: 95° F (35° C) DB / 75° F (24° C) WB

Electrical Requirements

Power Supply	208 / 230V, 1-Phase, 60 Hz
Breaker Size	15 A

Voltage

Indoor - Outdoor S1-S2	AC 208 / 230V
Indoor - Outdoor S2-S3	DC +/- 24V
Indoor - Remote Controller.....	MKH1 DC 3V PAR-31MAA DC 12V PAC-YT53CRAU DC 12V

Operating Conditions

Cooling

Indoor Intake Air Temp. (Max.)	90° F (32° C) DB / 73° F (23° C) WB
	(Min.) 67° F (19° C) DB / 57° F (14° C) WB
Outdoor Intake Air Temp. (Max.)	115° F (46° C) DB
	(Min.) 14° F (-10° C) DB

Indoor Unit

MCA.....	1.0 A
Blower Motor (ECM).....	0.76 F.L.A.
Blower Motor Output.....	30 W
Airflow (Quiet - Lo - Med - Hi - Super Hi)	
Cooling	145-170-237-321-399 Dry CFM 109-134-201-286-364 Wet CFM
Sound Pressure Level (Quiet - Lo - Med - Hi - Super Hi)	
Cooling	19-22-30-37-43 dB(A)
External Finish Color	Munsell 1.0Y 9.2/0.2
Dimension Unit	
Inches:.....	11-5/8 H x 31-7/16 W x 9-1/8 D
mm:	295 H x 798 W x 232 D
Weight Unit.....	22 lbs. / 10kg
Field Drainpipe Size O.D.....	19/32" x 15 mm

Outdoor Unit

MCA.....	12 A
Fan Motor (ECM).....	0.50 F.L.A.
Sound Pressure Level	
Cooling *1.....	49 dB(A)
External Finish Color	Munsell 3Y 7.8/1.1
External Dimensions	
Inches:.....	21-5/8 H x 31-1/2 W x 11-1/4 D
mm:	550 H x 800 W x 285 D
Weight	77Lbs. / 35kg
Refrigerant Type	R410A
Refrigerant Pipe	
Gas Side O.D.....	3/8 " / 9.52 mm
Liquid Side O.D.....	1/4" / 6.35 mm
Refrigerant Pipe Length	
Height Difference (Max.).....	40' / 12 m
Length (Max.).....	65' / 20 m
Connection Method	
Indoor/Outdoor.....	Flared

DIMENSIONS: MSY-GE12NA-8 & MUY-GE12NA2

MSY-GE12NA-8

Unit: inch

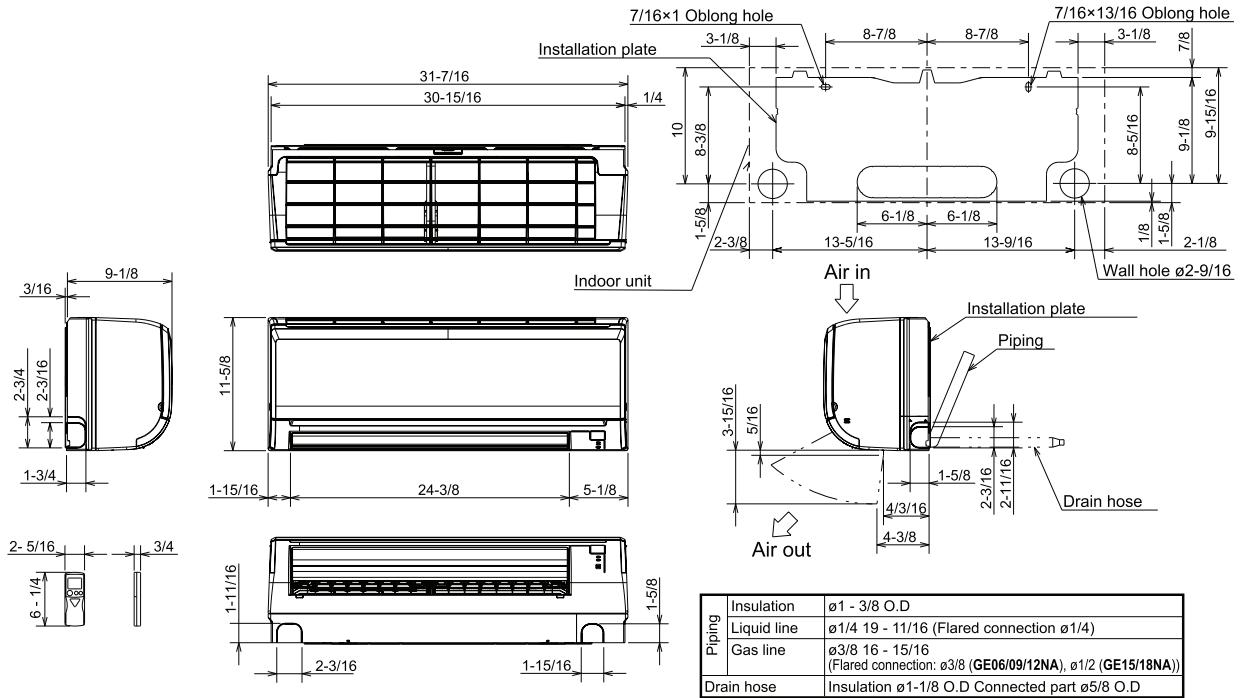

MUY-GE12NA2

Unit: inch

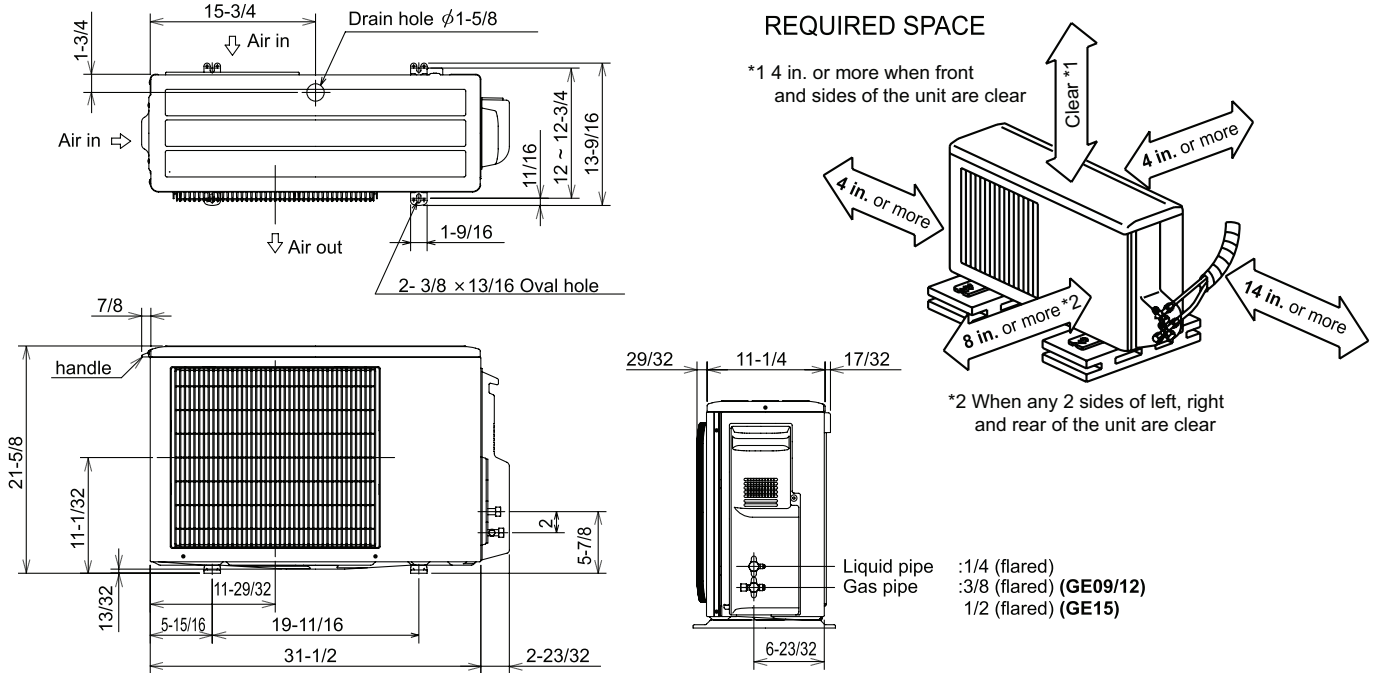

Intertek

INVERTER

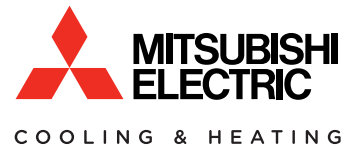

1340 Satellite Boulevard
Suwanee, GA 30024
Tele: 678-376-2900 • Fax: 800-889-9904
Toll Free: 800-433-4822
www.mehvac.com