

Job Name: _____

System Reference: _____ Date: _____



Indoor Unit: MSZ-FH12NA



Wireless Remote Controller



Outdoor Unit: MUZ-FH12NA

ACCESSORIES:

Indoor Unit

- Condensate Pump (BlueDiamond X87-711/721; 115/230V)
- Condensate Pump (Sauermann SI30-115/230; 115/230V)
- Replacement Platinum Deodorizing Filter (MAC-3000FT-E)
- Replacement Anti-allergy Enzyme Filter (MAC-2330FT-E)

Outdoor Unit

- Base Pan Heater (MAC-640BH-U)
- Drain Socket (MAC-860DS)

Controls

- Wireless Controller (MHK1)
- Wired Remote Controller PAR-31MAA (Requires MAC-333IF-E)
- Wireless Interface for kumo cloud™ (PAC-WHS01WF-E)
- Thermostat Interface (PAC-US444CN-1)

SPECIFICATIONS:

Rated Conditions (Capacity / Input)		
Cooling ¹	Btu/h / W	12,000 / 870
Heating at 47° F ²	Btu/h / W	13,600 / 950

Capacity Range		Minimum	Maximum
Cooling ¹	Btu/h	2,500	13,600
Heating at 47° F ²	Btu/h	3,700	21,000
Heating at 17° F ³	Btu/h	-	13,600
Heating at 5° F ⁴	Btu/h	-	13,600

1. Cooling | Indoor: 80° F (27° C) DB / 67° F (19° C) WB; Outdoor: 95° F (35° C) DB / 75° F (24° C) WB*
 2. Heating at 47° F | Indoor: 70° F (21° C) DB / 60° F (16° C) WB; Outdoor: 47° F (8° C) DB / 43° F (6° C) WB*
 3. Heating at 17° F | Indoor: 70° F (21° C) DB / 60° F (16° C) WB; Outdoor: 17° F (-8° C) DB / 15° F (-9° C) WB*
 4. Heating at 5° F | Indoor: 70° F (21° C) DB / 60° F (16° C) WB; Outdoor: 5° F (-15° C) DB / 5° F (-15° C) WB
- * Rating Conditions per AHRI Standard

Operating Conditions (Indoor Intake Air Temp.) (Max./ Min.)	
Cooling ⁵	90° F (32° C) DB / 67° F (19° C) DB
Heating	80° F (27° C) DB / 70° F (21° C) DB

Operating Conditions (Outdoor Intake Air Temp.) (Max./ Min.)	
Cooling ⁵	115° F (46° C) DB / 14° F (-10° C) DB
Heating	75° F (24° C) DB / -13° F (-25° C) DB**

⁵ Applications should be restricted to comfort cooling only; equipment cooling applications are not recommended for low ambient temperature conditions.
^{**} System cuts out at -18° F (-28° C) to avoid thermistor error and automatically restarts at -14° F (-26° C).

AHRI Efficiency Ratings	
SEER	26.1
HSPF	12.5
COP at 47° F	4.2
COP at 17° F	3.34

Energy Star® Yes

ENERGY STAR products are third-party certified by an EPA-recognized Certification Body.

Specifications are subject to change without notice.

Electrical Power Requirements	208 / 230V, 1-Phase, 60 Hz
-------------------------------	----------------------------

Minimum Circuit Ampacity (MCA)		
Indoor / Outdoor	A	1 / 11

Indoor Unit		
Blower Motor (ECM)	F.L.A.	0.67
Blower Motor Output	W	30
SHF / Moisture Removal		0.83 / 1.9 pt./h
Field Drainpipe Size O.D.	In.(mm)	5/8 (15)

Outdoor Unit		
Compressor		DC INVERTER-driven Twin Rotary
Fan Motor (ECM)	F.L.A.	0.50

Airflow Rate (Lo - Med - Hi - Super Hi - Powerful)			
Indoor (Cooling)	DRY	CFM	137-167-221-304-398
	WET		117-143-190-261-342
Indoor (Heating)	DRY		140-167-225-325-454
			1,190 / 1,320
Outdoor			

Sound Pressure Level (Lo - Med - Hi - Super Hi - Powerful)			
Indoor	Cooling	dB(A)	21-24-29-36-41
	Heating		21-24-29-36-42
Outdoor	Cooling		49
	Heating		51

External Dimensions		
Indoor (H x W x D)	In.(mm)	12 + 11/16 x 36-7/16 x 9-3/16 (305 +17 x 925 x 234)
Outdoor (H x W x D)		21-5/8 x 31-1/2 x 11-1/4 (550 x 800 x 285)

Net Weight		
Indoor	Lbs.(kg)	29 (12)
Outdoor		83 (38)

External Finish	
Indoor	Munsell 1.0Y 9.2 / 0.2
Outdoor	Munsell No. 3Y 7.8 / 1.1

Refrigerant	R410A ; 2 lb. 9 oz.
-------------	---------------------

Refrigerant Piping (Flared)		
Liquid (High Pressure)	In.(mm)	1/4 (6.35)
Gas (Low Pressure)		3/8 (9.52)
Max. Total Refrigerant Pipe Length (Height Diff.)	Ft. (m)	40 (12)
Max. Total Refrigerant Pipe Length (Length.)		65 (20)

DIMENSIONS: MSZ-FH12NA & MUZ-FH12NA

MSZ-FH12NA

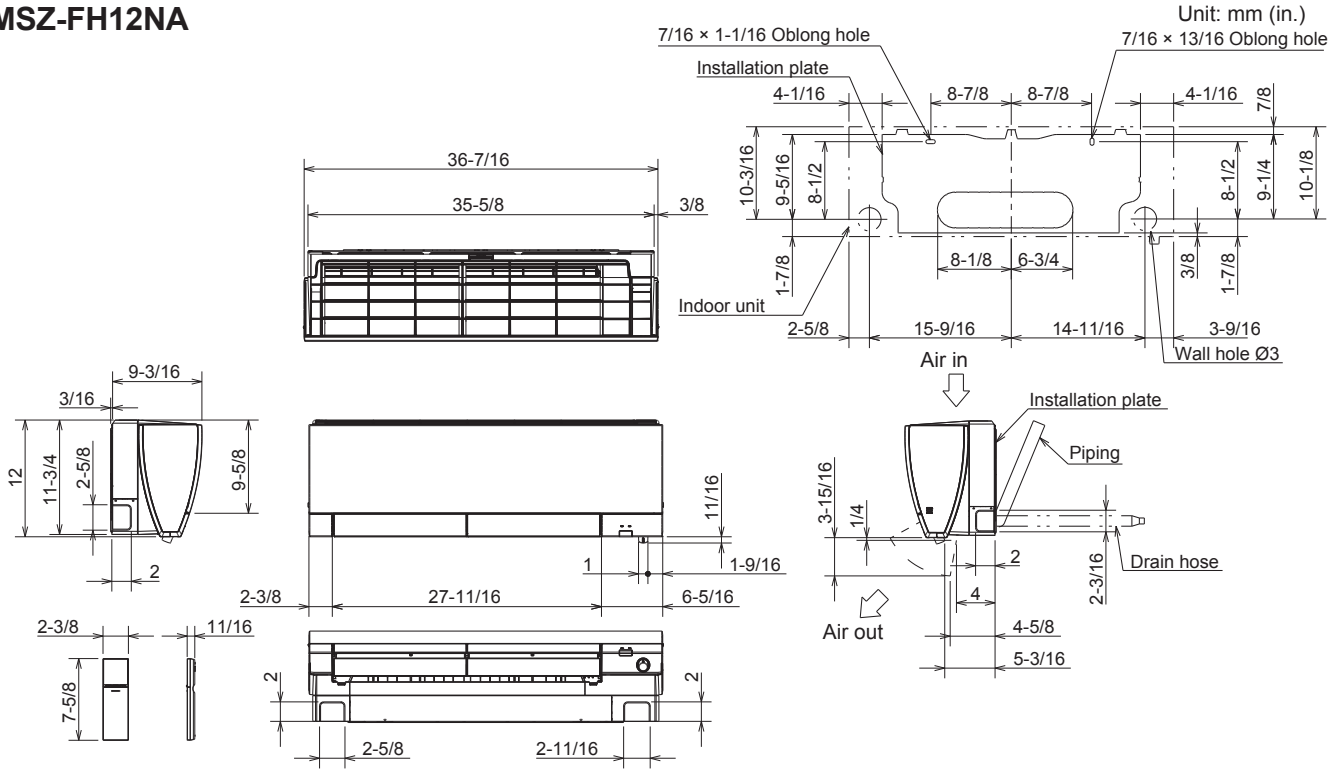

MUZ-FH12NA

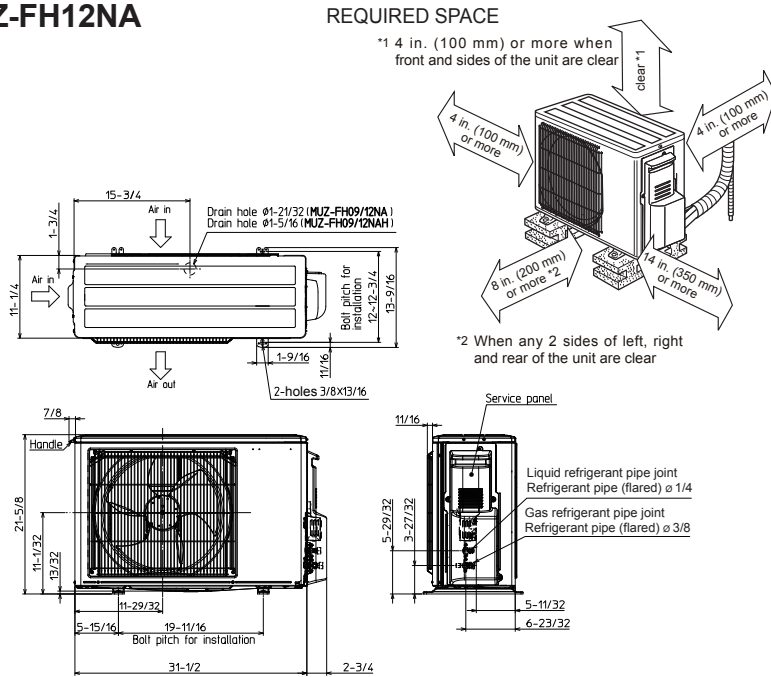

COOLING & HEATING

1340 Satellite Boulevard, Suwanee, GA 30024
 Toll Free: 800-433-4822 www.mehvac.com

