

# PERMIT ISSUED

**City of Portland, Maine - Building or Use Permit Application**  
 389 Congress Street, 04101 Tel: (207) 874-8703, Fax: (207) 874-8716

|                       |                                   |                     |
|-----------------------|-----------------------------------|---------------------|
| Permit No:<br>03-0857 | Issue Date:<br><b>JUL 22 2003</b> | CBL:<br>131 K004001 |
|-----------------------|-----------------------------------|---------------------|

|   |   |  |                        |
|---|---|--|------------------------|
| Location of Construction:<br>112 Pleasant Ave | Owner Name:<br>Capelluti Joseph H &       | Owner Address:<br>112 Pleasant Ave <b>CITY OF PORTLAND</b> | Phone:<br>207-774-3827 |
| Business Name:                                | Contractor Name:<br>Ledgewater Pools Inc. | Contractor Address:<br>223 Woodville Road Falmouth         | Phone:                 |
| Lessee/Buyer's Name                           | Phone:                                    | Permit Type:<br>Swimming Pools                             | Zone:<br><b>R-5</b>    |

|                            |  |  |                              |   |
|----------------------------|--|--|------------------------------|---|
| Past Use:<br>single family | Proposed Use:<br>single family - install inground 14' x 29' oval swimming pool | Permit Fee:<br>\$228.00  | Cost of Work:<br>\$23,000.00 | CEO District:<br>3  |
|                            |  | FIRE DEPT: <input type="checkbox"/> Approved <input checked="" type="checkbox"/> Denied<br>Signature: <i>[Signature]</i> |                              | INSPECTION:<br>Use Group: <b>U</b> Type: <b>Pool</b><br><b>BOCA 99</b><br>Signature: <i>[Signature]</i> |

**Proposed Project Description:**  
 install inground 14' x 29' oval swimming pool

**PEDESTRIAN ACTIVITIES DISTRICT (P.A.D.)**

Action:  Approved  Approved w/Conditions  Denied

Signature: \_\_\_\_\_ Date: \_\_\_\_\_

|                          |                                 |                        |
|--------------------------|---------------------------------|------------------------|
| Permit Taken By:<br>trmm | Date Applied For:<br>07/22/2003 | <b>Zoning Approval</b> |
|--------------------------|---------------------------------|------------------------|

1. This permit application does not preclude the Applicant(s) from meeting applicable State and Federal Rules.
2. Building permits do not include plumbing, septic or electrical work.
3. Building permits are void if work is not started within six (6) months of the date of issuance. False information may invalidate a building permit and stop all work..

|  |   |   |
|--|---|---|
| <b>Special Zone or Reviews</b><br><input type="checkbox"/> Shoreland<br><input type="checkbox"/> Wetland<br><input type="checkbox"/> Flood Zone<br><input type="checkbox"/> Subdivision<br><input type="checkbox"/> Site Plan<br>Maj <input type="checkbox"/> Minor <input type="checkbox"/> MM <input type="checkbox"/><br>Date: <b>7/22/03</b> | <b>Zoning Appeal</b><br><input type="checkbox"/> Variance<br><input type="checkbox"/> Miscellaneous<br><input type="checkbox"/> Conditional Use<br><input type="checkbox"/> Interpretation<br><input type="checkbox"/> Approved<br><input type="checkbox"/> Denied<br>Date: _____ | <b>Historic Preservation</b><br><input checked="" type="checkbox"/> Not in District or Landmark<br><input type="checkbox"/> Does Not Require Review<br><input type="checkbox"/> Requires Review<br><input type="checkbox"/> Approved<br><input type="checkbox"/> Approved w/Conditions<br><input type="checkbox"/> Denied<br>Date: <b>7/22/03</b> |
|--|---|---|

**PERMIT ISSUED**

**JUL 22 2003**

**CITY OF PORTLAND**

### CERTIFICATION

I hereby certify that I am the owner of record of the named property, or that the proposed work is authorized by the owner of record and that I have been authorized by the owner to make this application as his authorized agent and I agree to conform to all applicable laws of this jurisdiction. In addition, if a permit for work described in the application is issued, I certify that the code official's authorized representative shall have the authority to enter all areas covered by such permit at any reasonable hour to enforce the provision of the code(s) applicable to such permit.

SIGNATURE OF APPLICANT \_\_\_\_\_ ADDRESS \_\_\_\_\_ DATE \_\_\_\_\_ PHONE \_\_\_\_\_

RESPONSIBLE PERSON IN CHARGE OF WORK, TITLE \_\_\_\_\_ DATE \_\_\_\_\_ PHONE \_\_\_\_\_

# DISPLAY THIS CARD ON PRINCIPAL FRONTAGE OF WORK CITY OF PORTLAND

Please Read  
Application And  
Notes, If Any,  
Attached

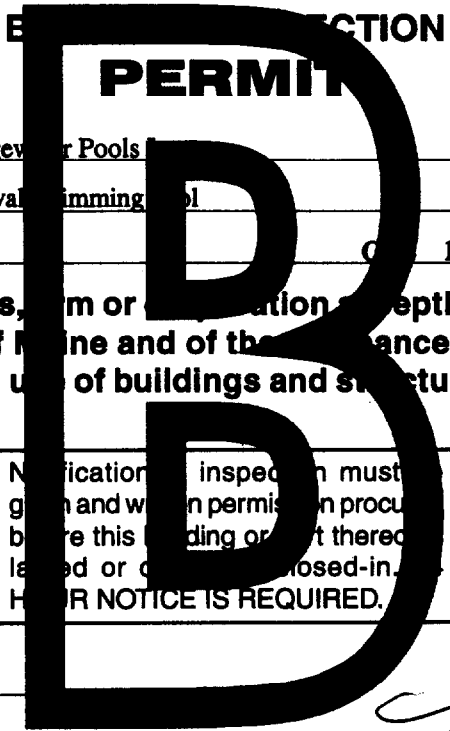

Permit Number: 030857

This is to certify that Capelluti Joseph H &/Ledger Pools  
has permission to install inground 14' x 29' oval swimming pool  
AT 112 Pleasant Ave 131 K004001

provided that the person or persons, firm or corporation accepting this permit shall comply with all of the provisions of the Statutes of the State and of the Ordinances of the City of Portland regulating the construction, maintenance and use of buildings and structures, and of the application on file in this department.

Apply to Public Works for street line and grade if nature of work requires such information.

Notification of inspection must be given and work on permit in progress before this building or part thereof is leased or occupied. 24 HOUR NOTICE IS REQUIRED.

A certificate of occupancy must be procured by owner before this building or part thereof is occupied.

**OTHER REQUIRED APPROVALS**

Fire Dept. PERMIT ISSUED  
Health Dept. \_\_\_\_\_  
Appeal Board \_\_\_\_\_  
Other JUL 22 2003  
Department Name

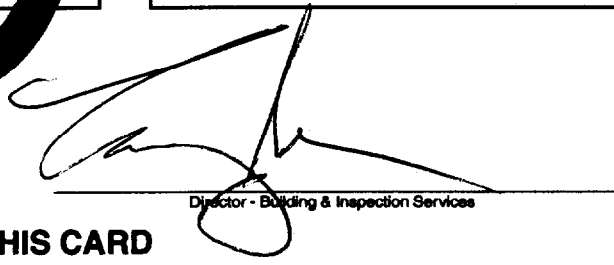
  
Director - Building & Inspection Services

**CITY OF PORTLAND**

**PENALTY FOR REMOVING THIS CARD**

Gate will have  
lock @ 54" above  
grade - on outside  
of fence + will have  
self closer

6' high  
Solid wooden  
fence

4' high  
solid fence

Gate will open  
away - w/ self  
closing device -  
latch will be 3" below  
top of fence on  
pool side.

6' high  
Solid fence

4' high  
chain link  
fence - will add slats  
to reduce openings

1" = 20'

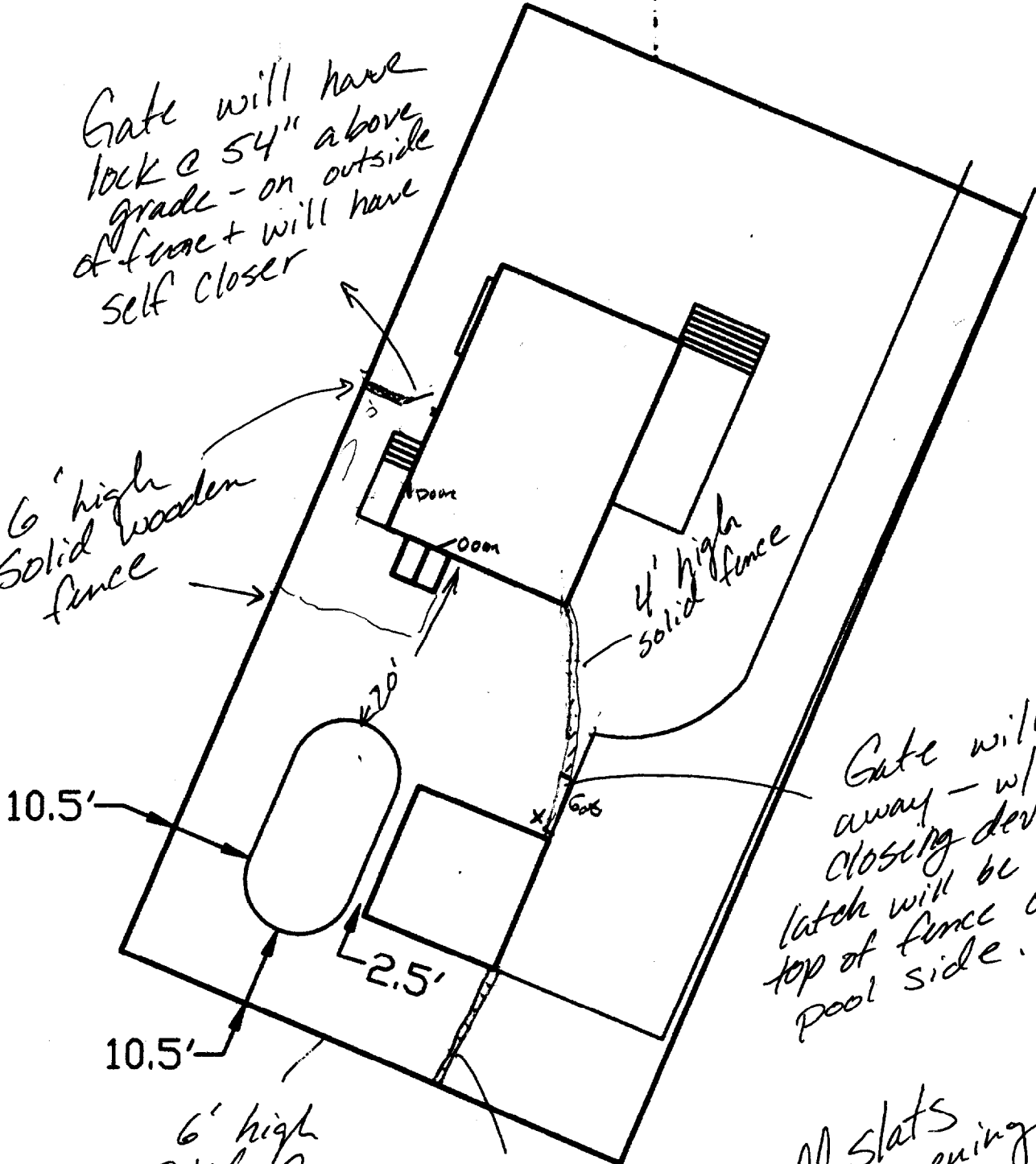

# BUILDING PERMIT INSPECTION PROCEDURES

Please call 874-8703 or 874-8693 to schedule your inspections as agreed upon

Permits expire in 6 months, if the project is not started or ceases for 6 months.

The Owner or their designee is required to notify the inspections office for the following inspections and provide adequate notice. Notice must be called in 48-72 hours in advance in order to schedule an inspection:

By initializing at each inspection time, you are agreeing that you understand the inspection procedure and additional fees from a "Stop Work Order" and "Stop Work Order Release" will be incurred if the procedure is not followed as stated below.

**Pre-construction Meeting:** Must be scheduled with your inspection team upon receipt of this permit. Jay Reynolds, Development Review Coordinator at 874-8632 must also be contacted at this time, before any site work begins on any project other than single family additions or alterations.

**Footing/Building Location Inspection:** Prior to pouring concrete

*Setbacks*

*N/A* **Re-Bar Schedule Inspection:** Prior to pouring concrete

*N/A* **Foundation Inspection:** Prior to placing ANY backfill

**Framing/Rough Plumbing/Electrical:** Prior to any insulating or drywalling

**Final/Certificate of Occupancy:** Prior to any occupancy of the structure or use. NOTE: There is a \$75.00 fee per inspection at this point.

Certificate of Occupancy is not required for certain projects. Your inspector can advise you if your project requires a Certificate of Occupancy. All projects DO require a final inspection

       If any of the inspections do not occur, the project cannot go on to the next phase, REGARDLESS OF THE NOTICE OR CIRCUMSTANCES.

       **CERIFICATE OF OCCUPANICES MUST BE ISSUED AND PAID FOR, BEFORE THE SPACE MAY BE OCCUPIED**

*J. J. Gallant*  
Signature of applicant/designee

        
Date

*2/22/03*

        
Signature of Inspections Official

        
Date

CBL: *131-K-4* Building Permit #: *03-0857*

# Pool Installation/Construction Permit Application

If you or the property owner owes real estate or personal property taxes or user charges on any property within the City, payment arrangements must be made before permits of any kind are accepted.

|   |   |   |
|---|---|---|
| Location/Address of Construction: <u>112 Pleasant Ave.</u>  |   |   |
| Total Square Footage of Proposed Structure  |   | Square Footage of Lot                           |
| Tax Assessor's Chart, Block & Lot<br>Chart#      Block#      Lot#   | Owner: <u>Joseph &amp; Vanessa Capelluti</u>              | Telephone: <u>774-3827</u>                      |
| Lessee/Buyer's Name (If Applicable)   | Applicant name, address & telephone: <u>Same as Above</u> | Cost Of Work: \$ <u>23,000</u><br>Fee: \$ _____ |
| Dimensions of pool: <u>14 x 29</u> Above or below ground: <u>Below</u>  |   |   |
| Dimensions of decking and/or any platforms, sheds, or other structures: <u>NONE</u>   |   |   |
| Contractor's name, address & telephone: <u>Ledgewake Pools, Inc. 223 Woodville Rd. Falmouth, Maine 797-7752</u>   |   |   |
| Whom should we contact when the permit is ready: <u>Joseph Capelluti</u>  |   |   |
| Mailing address: <u>112 Pleasant Ave. Portland, Maine 04103</u>   |   |   |
| We will contact you by phone when the permit is ready. You must come in and pick up the permit and review the requirements before starting any work, with a Plan Reviewer. <b>A stop work order will be issued and a \$100.00 fee if any work starts before the permit is picked up.</b> PHONE: <u>774-3827</u> |   |   |

**IF THE REQUIRED INFORMATION IS NOT INCLUDED IN THE SUBMISSIONS THE PERMIT WILL BE AUTOMATICALLY DENIED AT THE DISCRETION OF THE BUILDING/PLANNING DEPARTMENT, WE MAY REQUIRE ADDITIONAL INFORMATION IN ORDER TO APPROVE THIS PERMIT.**

*I hereby certify that I am the Owner of record of the named property, or that the owner of record authorizes the proposed work and that I have been authorized by the owner to make this application as his/her authorized agent. I agree to conform to all applicable laws of this jurisdiction. In addition, if a permit for work described in this application is issued, I certify that the Code Official's authorized representative shall have the authority to enter all areas covered by this permit at any reasonable hour to enforce the provisions of the codes applicable to this permit.*

|   |             |
|---|-------------|
| Signature of applicant: <u>Joseph Capelluti</u> | Date: _____ |
|---|-------------|

**This is NOT a permit; you may not commence ANY work until the permit is issued. If you are in a Historic District you may be subject to additional permitting and fees with the Planning Department on the 4<sup>th</sup> floor of City Hall**

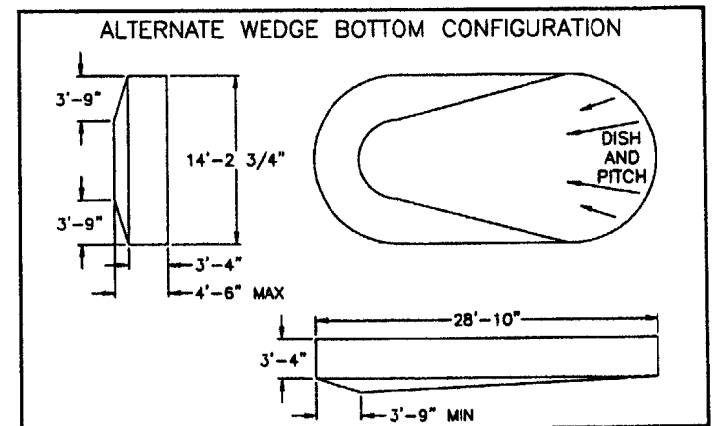
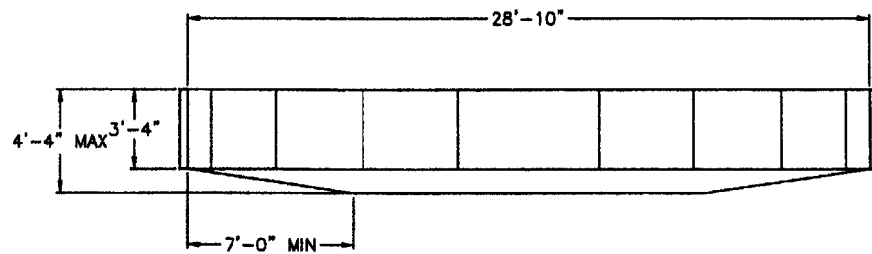
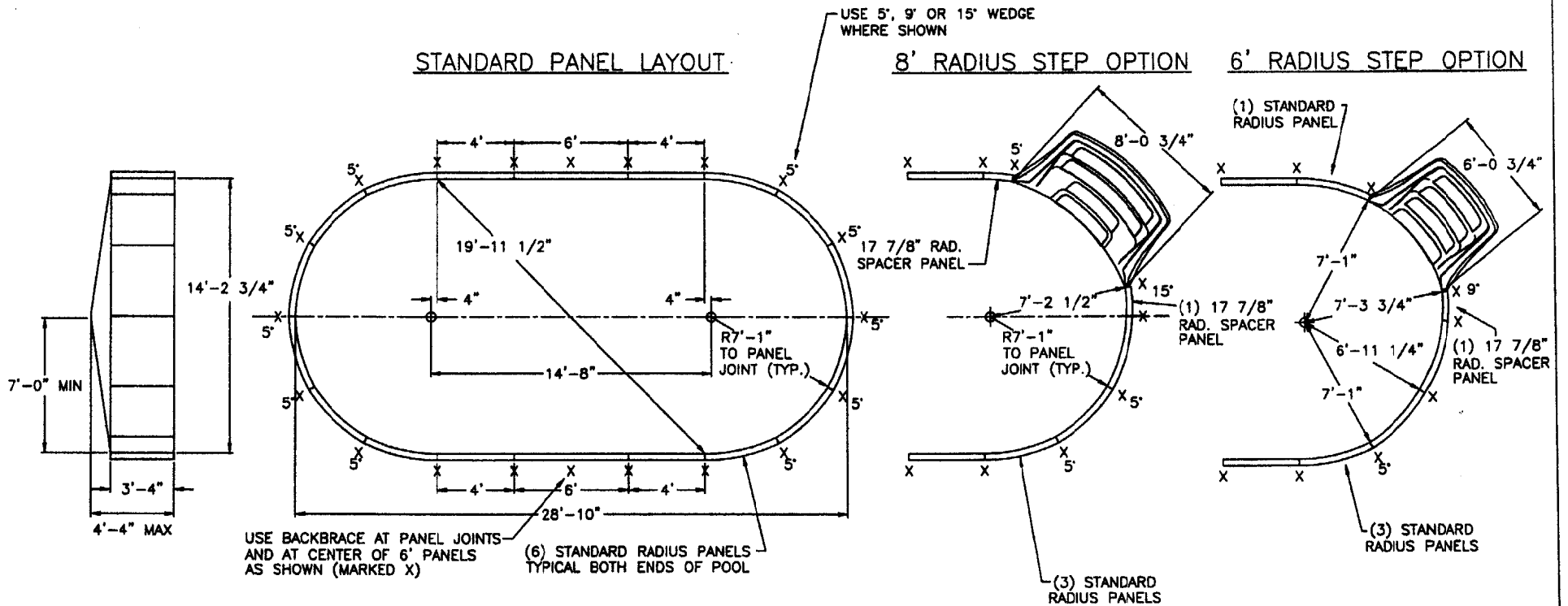

**NON-DIVING POOL**  
USE OF DIVING EQUIPMENT IS PROHIBITED

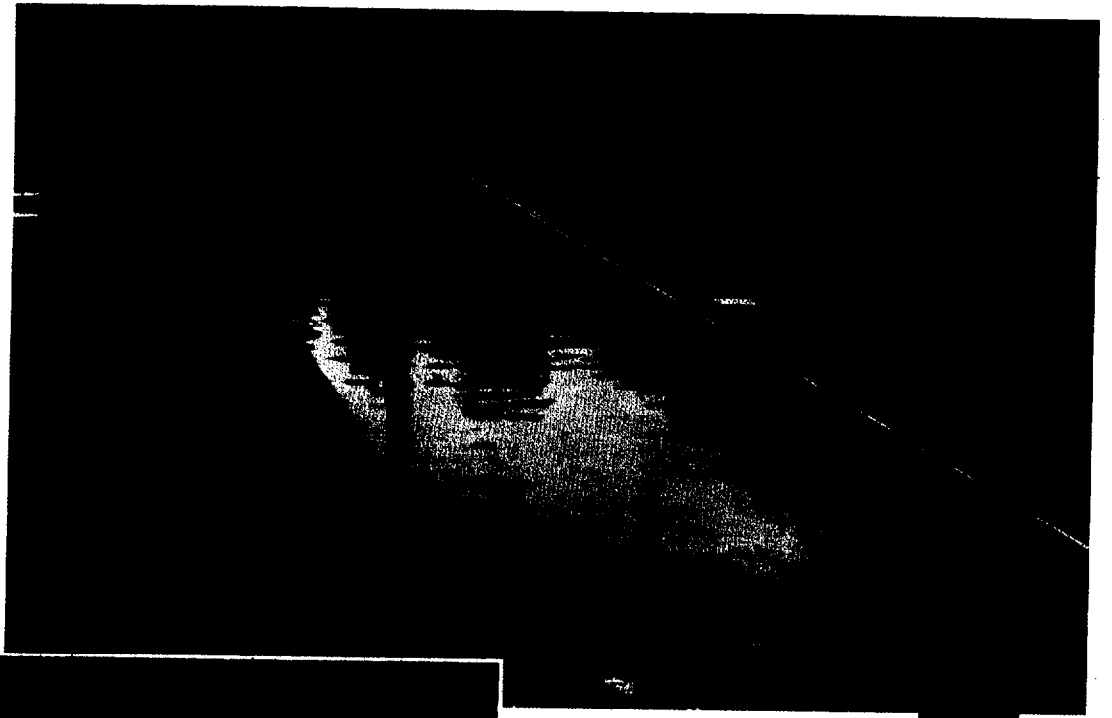

16

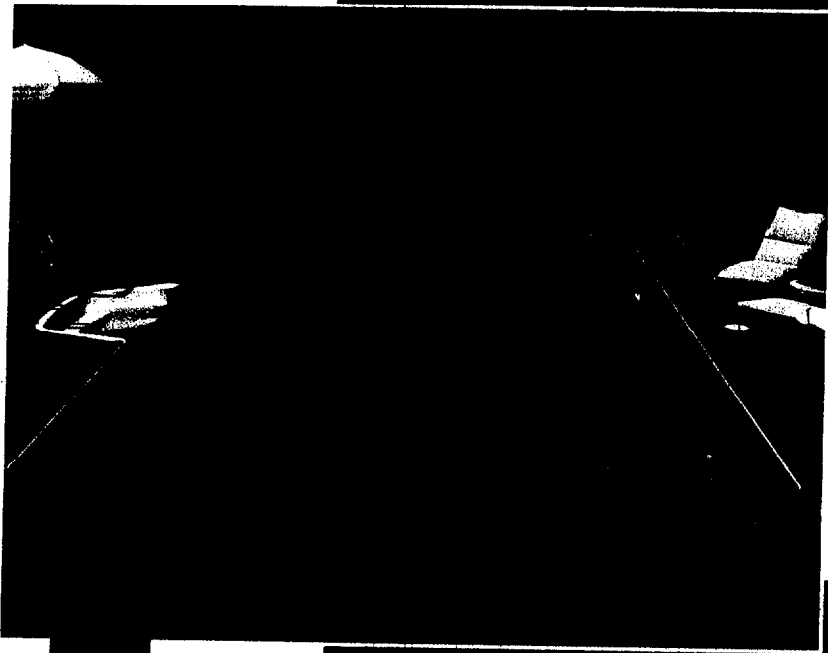

17

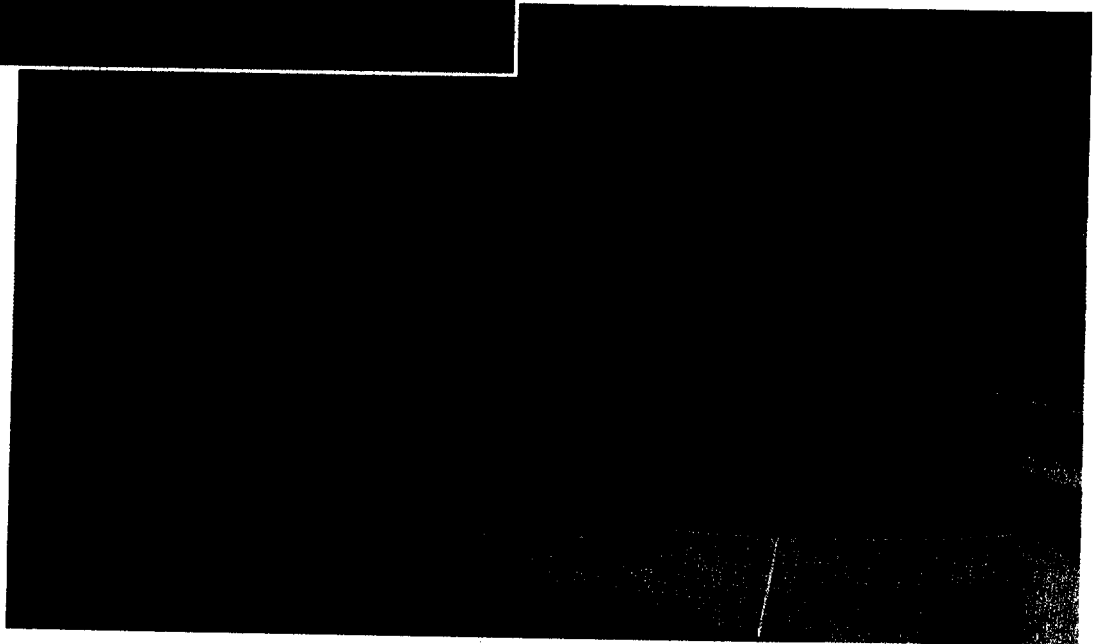

18