

# Installation and Service Instructions

for use by heating contractor



## Vitodens 100-W

### B1HA Series and B1KA Combi Boiler

Wall-Mounted, gas-fired condensing boilers

On demand domestic hot water with Combi boiler

Heating input: 21 to 125 MBH  
6.2 to 36.6 kW



## VITODENS® 100-W



### IMPORTANT

Read and save these instructions for future reference.

## Safety, Installation and Warranty Requirements

Please ensure that these instructions are read and understood before commencing installation. Failure to comply with the instructions listed below and details printed in this manual can cause product/property damage, severe personal injury, and/or loss of life. Ensure all requirements below are understood and fulfilled (including detailed information found in manual subsections).

■ **Product documentation**

Read all applicable documentation before commencing installation. Store documentation near boiler in a readily accessible location for reference in the future by service personnel.

► *For a listing of applicable literature, please see section entitled "Important Regulatory and Safety Requirements".*



■ **Warranty**

Information contained in this and related product documentation must be read and followed. Failure to do so renders the warranty null and void.



■ **Licensed professional heating contractor**

The installation, adjustment, service and maintenance of this equipment must be performed by a licensed professional heating contractor.

► *Please see section entitled "Important Regulatory and Installation Requirements".*



■ **Contaminated air**

Air contaminated by chemicals can cause by-products in the combustion process, which are poisonous to inhabitants and destructive to Viessmann equipment.

► *For a listing of chemicals which cannot be stored in or near the boiler room, please see subsection entitled "Combustion Air Supply".*



■ **Advice to owner**

Once the installation work is complete, the heating contractor must familiarize the system operator/ultimate owner with all equipment, as well as safety precautions/requirements, shutdown procedure, and the need for professional service annually before the heating season begins.

■ **Carbon monoxide**

Improper installation, adjustment, service and/or maintenance can cause flue products to flow into living space. Flue products contain poisonous carbon monoxide gas.

► *For information pertaining to the proper installation, adjustment, service and maintenance of this equipment to avoid formation of carbon monoxide, please see instructions supplied with burner.*



■ **Fresh air**

This equipment requires fresh air for safe operation and must be installed ensuring provisions for adequate combustion and ventilation air exist.

► *For information pertaining to the fresh air requirements of this product, please see subsection entitled "Combustion Air Supply".*

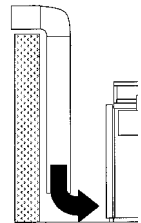

■ **Equipment venting**

Never operate boiler without an installed venting system. An improper venting system can cause carbon monoxide poisoning.

► *For information pertaining to venting and chimney requirements, please see section entitled "Venting Connection". All products of combustion must be safely vented to the outdoors.*



**! WARNING**

**Installers must follow local regulations with respect to installation of carbon monoxide detectors. Follow manufacturer's maintenance schedule of the boiler.**

<b>Safety</b>	<b>Safety, Installation and Warranty Requirements</b> .....	2
	<b>Important Regulatory and Installation Requirements</b> .....	5
<b>General Information</b>	<b>About these Installation Instructions</b> .....	7
	<b>Applicability</b> .....	8
	<b>Product Information</b> .....	8
<b>Dimensions</b>	<b>Mechanical Room</b> .....	9
	<b>Minimum Clearances</b> .....	10
	<b>Boiler Dimensions</b> .....	10
	<b>Boiler Mounting</b> .....	13
<b>Connections</b>	<b>Boiler Connections</b> .....	17
	Vent connections .....	17
	Proper piping practice .....	18
	Gas connection and piping.....	18
	Gas piping pressure test.....	19
	Heating water connections .....	20
	Condensate connection.....	21
	Fill siphon with water .....	21
	<b>Safety Connections and Pressure Testing</b> .....	22
	Installing safety devices on the boiler.....	22
	Low water cut-off .....	22
	Hot water temperature and system pressure.....	23
	Performing pressure test on the boiler.....	23
	<b>Installation Examples</b> .....	24
	General .....	24
	Clearances .....	24
	Heating circuit pumps .....	24
	Waterside flow .....	25
	Built-in pump .....	26
	B1HA with one heating circuit .....	27
	B1HA with one heating circuit, DHW tank and LLH .....	28
	B1HA with one heating circuit and DHW tank.....	29
	B1KA with one heating circuit.....	30
	B1KA with one heating circuit and LLH .....	31
	B1KA with one heating circuit without LLH .....	32
	Boiler in heating/cooling application .....	33
	Boiler with low water cut-off (remote mounted, field supplied) .....	34
	<b>Venting</b> .....	34
	<b>Neutralization Unit</b> .....	35
	<b>Accessing Electrical Connections</b> .....	36
<b>Control Connections</b>	<b>Accessing Electrical Connections</b> .....	36
	Removing the front cover .....	36
	Rotating the control unit and opening the power/pump module.....	36
	Optional operating control - OpenTherm (OT) .....	37
	Room thermostat connect .....	37
	Closing the control unit .....	38
	Reinstalling the front panel .....	38

	Page
<b>Start-up, Inspection and Maintenance</b>	
Necessary Tools .....	39
Testing/analysis equipment.....	39
Overview of Controls and Indicators .....	39
Control and display elements .....	39
Check Power Supply Connection.....	39
Setup Menu Overview .....	40
Filling and Bleeding the Heating System .....	40
Select Appropriate Gas Type .....	42
Converting Gas Type on the Control Unit .....	42
Measure Static Pressure and Running Pressure.....	42
Checking the CO <sub>2</sub> Content/Relay Tests .....	44
High Altitude Setting .....	45
Setting Required Heating Input.....	45
Configuring DHW Tank Sensor Input.....	46
Setting the Unit of Measurement (temperature unit).....	46
Setting the DHW Comfort Function .....	46
Clock Natural Gas Meter .....	47
Check all Primary and Secondary Circuit Connections for Leaks.....	47
Perform Combustion Analysis .....	47
Check Venting System for Leaks.....	48
Removing the front Panel .....	48
Removing the Burner .....	49
Check Burner Gasket and Cylinder Assembly for Damage .	49
Check and Adjust Ignition and Ionization Electrodes.....	50
Check Condensate Drain and Clean Siphon.....	50
Check Neutralization Unit .....	51
Clean Combustion Chamber/Heat Exchanger Surfaces... .	51
Check Diaphragm Expansion Tank and System Pressure .	52
Check Function of Safety Valves.....	52
Check Gas Pipes and Fittings for Leaks .....	52
Install Burner .....	53
Reinstall Front Panel .....	53
<b>Troubleshooting</b>	
Troubleshooting Steps .....	54
Changing Room Temperature .....	54
Diagnosis .....	55
Boiler Connection .....	58
<b>Additional Information</b>	
Electrical Connections to the Terminal Strip for Accessories .	64
Technical Data .....	65
Burner Program Sequence of Operation .....	69
B1HA 26, 35 Wiring Diagram .....	71
B1KA 35 Wiring Diagram .....	72
Parts List.....	73
Installation Fittings .....	84
Maintenance Record .....	85
Lighting and Operating Instructions.....	86

## Important Regulatory and Installation Requirements

### Codes

The installation of this unit shall be in accordance with local codes or, in the absence of local codes, use CAN/CSA-B149.1 or .2 Installation Codes for Gas Burning Appliances for Canada. For U.S. installations use the National Fuel Gas Code ANSI Z223.1. Always use latest editions of codes.

- ▶ *Leave all literature at the installation site and advise the system operator/ultimate owner where the literature can be found. Contact Viessmann for additional copies.*

In Canada all electrical wiring is to be done in accordance with the latest edition of CSA C22.1 Part 1 and/or local codes. In the U.S. use the National Electrical Code ANSI/NFPA 70. The heating contractor must also comply with both the Standard for Controls and Safety Devices for Automatically Fired Boilers, ANSI/ASME CSD-1, and the Installation Code for Hydronic Heating Systems, CSA B214 (latest edition), where required by the authority having jurisdiction.

- ▶ *This product comes with several safety instruction labels attached. Do not remove! Contact Viessmann immediately if replacement labels are required.*

CSD-1 Field Testing of High Limit Switches for Vitodens boilers – where required by law.

VISSMANN IS NOT RESPONSIBLE FOR ANY DAMAGES THAT THE FOLLOWING TEST PROCEDURE MAY RESULT IN BY OVERHEATING THE SYSTEM.

The Vitodens 100/200 boilers are equipped with flow switches that when activated disable or enable the burner to operate.

The fixed high limit, when tripped, produces a fault that will require manual reset of the boiler control.

Fixed High Limit fault simulation method #1:

- Close the boiler valve and jump the flow switch.
- Run the boiler at high fire and it will shut down by the coding card (in WB2B models, set coding address 06 to max.) but should continue to stack the boiler temp until the fixed high limit is tripped.
- Once the fixed high limit is tripped, slowly open the boiler valve to safely cool the boiler down.

Fixed High Limit fault simulation method #2:

- Throttle the boiler valve to a point where the burner will run with as little flow as possible.
- Run the boiler to high fire via relays test.
- When the burner shuts down on the electronic limit, close the ball valve to stop the flow.
- The boiler temp should continue to stack to trip the fixed high limit.
- Once the fixed high limit is tripped, slowly open the boiler valve to safely cool the boiler down.

Fixed High Limit fault simulation method #3:

- Remove one of the wires connected to limit switch, this will produce a fault in the boilers control that requires manual reset.

**Important Regulatory and Installation Requirements** *(continued)*

For installations on the Commonwealth of Massachusetts, the following modifications to NFPA-54 chapter 10 apply:  
Excerpt from 248 CMR 5-08:

- 2(a) For all side-wall horizontally vented gas fueled equipment installed in every dwelling, building or structure used in whole or in part for residential purposes, including those owned or operated by the Commonwealth and where the side-wall exhaust vent termination is less than (7) feet above finished grade in the area of the venting, including but not limited to decks and porches, the following requirements shall be satisfied:
1. **INSTALLATION OF CARBON MONOXIDE DETECTORS.** At the time of installation of the side-wall horizontal vented gas fueled equipment, the installing plumber or gas fitter shall observe that a hard wired carbon monoxide detector with an alarm and battery back-up is installed on the floor level where the gas equipment is to be installed. In addition, the installing plumber or gas fitter shall observe that a battery operated or hard wired carbon monoxide detector with an alarm is installed on each additional level of the dwelling, building or structure served by the side-wall horizontal vented gas fueled equipment. It shall be the responsibility of the property owner to secure the services of qualified licensed professional for the installation of hard-wired carbon monoxide detectors.
    - a. In the event that the side-wall horizontally vented gas fueled equipment is installed in a crawl space or an attic, the hard-wired carbon monoxide detector with alarm and battery back-up may be installed on the next adjacent floor level.
    - b. In the event that the requirements of this subdivision can not be met at the time of completion of installation, the owner shall have a period of thirty (30) days to comply with the above requirements; provided, however, that during said thirty (30) day period, a battery operated carbon monoxide detector with an alarm shall be installed.
  2. **APPROVED CARBON MONOXIDE DETECTORS.** Each carbon monoxide detector as required in accordance with the above provisions shall comply with NFPA 720 and be ANSI/UL 2034 listed and IAS certified.
  3. **SIGNAGE.** A metal or plastic identification plate shall be permanently mounted to the exterior of the building at a minimum height of eight (8) feet above grade directly in line with the exhaust vent terminal for the horizontally vented gas fueled heating appliance or equipment. The sign shall read, in print size no less than one-half (1/2) inch in size, "GAS VENT DIRECTLY BELOW. KEEP CLEAR OF ALL OBSTRUCTIONS".
  4. **INSPECTION.** The state or local gas inspector of the side-wall horizontally vented gas fueled equipment shall not approve the installation unless, upon inspection, the inspector observes carbon monoxide detectors and signage installed in accordance with the provisions of 248 CMR 5.08(2)(a) 1 through 4.
- (b) **EXEMPTIONS:** The following equipment is exempt from 248 CMR 5.08(2)(a) 1 through 4:
1. The equipment listed in Chapter 10 entitled "Equipment Not Required To Be Vented" in the most current edition of NFPA 54 as adopted by the Board; and
  2. Product Approved side-wall horizontally vented gas fueled equipment installed in a room or structure separate from the dwelling, building or structure used in whole or in part for residential purposes.

**Important Regulatory and Installation Requirements** *(continued)*

**Working on the equipment**

The installation, adjustment, service, and maintenance of this boiler must be performed by a licensed professional heating contractor who is qualified and experienced in the installation, service, and maintenance of hot water boilers. There are no user serviceable parts on the boiler, burners, or control.

Ensure main power supply to equipment, the heating system, and all external controls has been deactivated. Close main gas supply valve. Take precautions in all instances to avoid accidental activation of power during service work.

**Technical literature**

Literature for the Vitodens boiler:

- Technical Data Manual
- Installation and Service Instructions
- Operating Instructions and User's Information Manual
- Vitodens Venting System Installation Instructions
- Quick Start Guide
- Instructions of other products utilized and installed
- Installation codes mentioned in this manual and as locally applicable

- ▶ *The completeness and functionality of field supplied electrical controls and components must be verified by the heating contractor. This includes low water cutoffs, flow switches (if used), staging controls, pumps, motorized valves, air vents, thermostats, etc.*
- ▶ *Leave all literature at the installation site and advise the system operator/ultimate owner where the literature can be found. Contact Viessmann for additional copies.*
- ▶ *This product comes with several safety instruction labels attached. Do not remove! Contact Viessmann immediately if replacement labels are required.*

**About these Installation Instructions**

 Take note of all symbols and notations intended to draw attention to potential hazards or important product information. These include "WARNING", "CAUTION", and "IMPORTANT". See below.

 **WARNING**

Indicates an imminently hazardous situation which, if not avoided, could result in death, serious injury or substantial product/property damage.

▶ *Warnings draw your attention to the presence of potential hazards or important product information.*

 **CAUTION**

Indicates an imminently hazardous situation which, if not avoided, may result in minor injury or product/property damage.

▶ *Cautions draw your attention to the presence of potential hazards or important product information.*

**IMPORTANT**

▶ *Helpful hints for installation, operation or maintenance which pertain to the product.*



▶ *This symbol indicates that additional, pertinent information is to be found.*

▶ *This symbol indicates that other instructions must be referenced.*

**IMPORTANT**

The boiler serial number must be provided when ordering replacement parts. Both the 16-digit serial number bar code label and the 12-digit ASME serial number correlate to each other. Providing either serial number is sufficient.

Model No.	Serial No.
B1HA 26	7560853□□□□□□□□
B1HA 35	7560854□□□□□□□□
B1KA 35	7560855□□□□□□□□

Stainless steel Inox-Radial heat exchanger

ASME stamp 12-digit serial number location (metallic plate riveted on the heat exchanger)

Serial No. location (16-digit bar code white label located inside the boiler compartment and underneath the boiler)

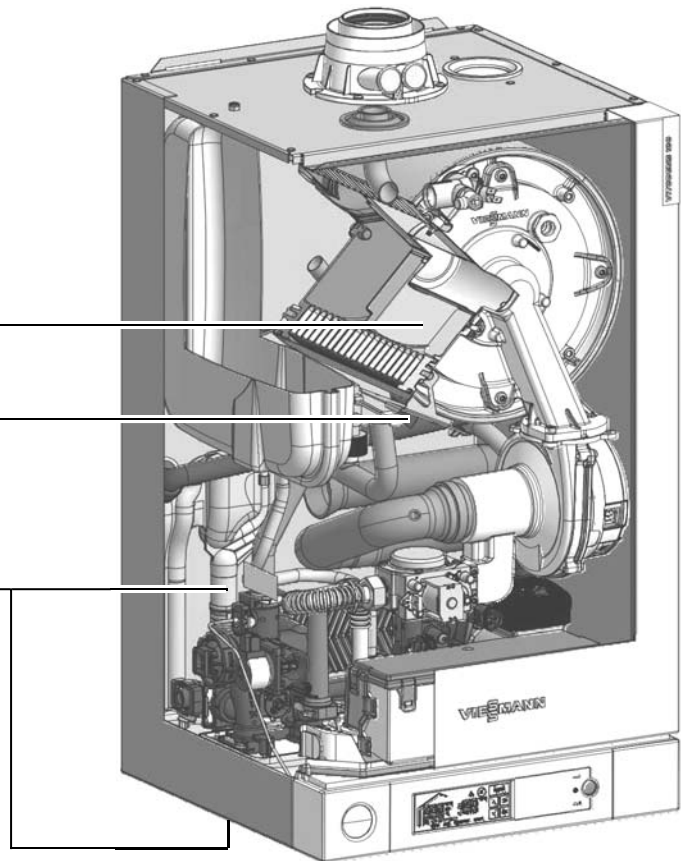

**Product Information**

The Vitodens 100-W B1HA is available as a gas condensing boiler for the connection of one DHW tank or as a gas condensing combi boiler B1KA with an integral plate heat exchanger for DHW heating. For the connection of heating circuits and the DHW tank or the DCW/DHW piping for the B1KA, see installation examples starting on page 27. In the factory set condition, the Vitodens 100-W is set up for operation with constant boiler water temperature. By connecting an outdoor temperature sensor (included with installation accessories), the boiler can be operated in weather-compensated mode. The following are integrated: closed loop hydraulic system with 2 connections for heating system supply and return, and 2 connections for DHW tank heating (B1HA) or on demand DHW heating (B1KA).

These boilers are only intended for installation in close loop heating systems. The following components are integrated into the boiler:

- Circulation pump
- 3-way diverter valve
- Pressure relief valve
- Diaphragm expansion vessel (B1KA only)
- Plate heat exchanger for DHW heating (B1KA only)



## Mechanical Room

During the early stages of new home design, we recommend that proper consideration be given to constructing a separate mechanical room dedicated to gas- or oil-fired equipment including domestic hot water storage tanks.

The boiler must be located in a heated indoor space, near a floor drain, and as close as possible to the wall.

Whenever possible, install boiler near an outside wall so that it is easy to duct the venting system to the boiler.

Locate boiler on walls capable of supporting the weight of the boiler filled with water (see section entitled "Technical Data" on page 66 for information required for total boiler weight calculation). Ensure that boiler location does not interfere with proper circulation of combustion and ventilation air of other fuel burning equipment (if applicable) within the mechanical room.

The maximum room temperature of the mechanical room where the boiler is located must not exceed 104°F (40°C).

### IMPORTANT

#### Boiler operation in marine environments (damp, salty coastal areas):

The service life of the boiler's exposed metallic surfaces, such as the casing and fan housing, is directly influenced by proximity to damp and salty marine environments. In such areas, higher concentration levels of chlorides from sea spray, coupled with relative humidity, can lead to degradation of the exposed metallic surfaces mentioned above. Therefore, it is imperative that boilers installed in such environments not be installed using direct vent systems which draw outdoor air for combustion. Such boilers must be installed using room air dependent vent systems; i.e. using room air for combustion. The indoor air will have a much lower relative humidity and, hence, potential corrosion will be minimized.



### WARNING

If you notice fire coming from the appliance, call the fire department immediately! Do not attempt to extinguish the fire unless qualified to do so.



### WARNING

Fire causes a risk of burns and explosion!

- Shut down the boiler
- Close fuel shut-off valves
- Use a tested fire extinguisher, class ABC.



### WARNING

Incorrect ambient conditions can lead to damage to the heating system and put safe operation at risk.

#### Installation area conditions

- Ensure ambient temperatures are higher than 32°F (0°C) and lower than 104°F (40°C).
- Prevent the air from becoming contaminated by halogenated hydrocarbons (e.g. as contained in paint solvents or cleaning fluids) and excessive dust (e.g. through grinding or polishing work). Combustion air for the heating process, and ventilation of the boiler room must be free of corrosive contaminants. To that end, any boiler must be installed in an area that has no chemical exposure. The list to the right indicates the main, currently known sources.
- Avoid continuously high levels of humidity (e.g. through frequent drying of laundry).
- Never close existing ventilation openings.

#### Sources of combustion and ventilation air contaminants.

##### Areas likely to contain contaminants:

- New building construction
- Swimming pools
- Remodelling areas, hobby rooms
- Garages with workshops
- Furniture refinishing areas
- Dry cleaning/laundry areas and establishments
- Auto body shops
- Refrigeration repair shops
- Metal fabrication plants
- Plastic manufacturing plants
- Photo processing plants
- Beauty salons

##### Products containing contaminants:

- Chlorine-type bleaches, detergents and cleaning solvents found in household laundry rooms
- Paint and varnish removers
- Hydrochloric acid, muriatic acid
- Chlorine-based swimming pool chemicals
- Spray cans containing chlorofluorocarbons
- Chlorinated waxes and cleaners
- Cements and glues
- Refrigerant leaks
- Calcium chloride used for thawing
- Sodium chloride used for water softening salt
- Permanent wave solutions
- Adhesives used to fasten building products and other similar items
- Antistatic fabric softeners used in clothes dryers

#### Before set-up

Before placing boiler in its installation location, ensure all necessary accessories are installed.



### CAUTION

The boiler must be installed in such a way that gas ignition system components are protected from water (spraying, splashing, etc.) during boiler operation and service.

# Minimum Clearances

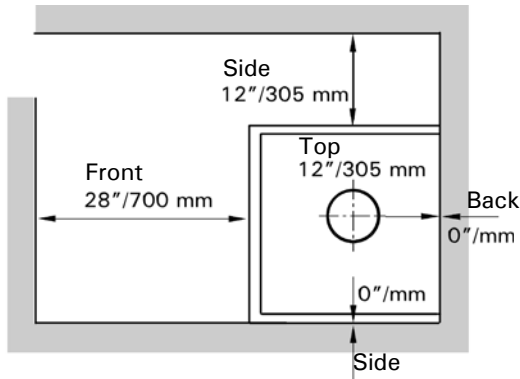

### Recommended minimum boiler clearances to combustibles

**Note:** The Vitodens 100-W boiler has passed the zero inches vent clearance to combustibles testing requirements dictated by the boiler Harmonized Standard ANSI Z21.13. CSA 4.9 (latest edition) and therefore is listed for zero clearance to combustibles when vented with a single-wall special venting system (AL-29-4C material) or UL/ULC-listed CPVC gas vent material. The zero inches vent clearance to combustibles for the Vitodens 100-W boiler supercedes the clearance to combustibles listing that appears on the special venting system label.

Top clearance - 12" (30 cm).



See the Vitodens Venting System Installation Instructions.

### Clearance to combustibles

Top	Front	Rear	Left	Right	Vent pipe *1
0	0 AL, CL	0	0	0	0

\*1 Refer to the Installation Instructions of the Vitodens Venting System for details.

AL = Alcove  
CL = Closet

# Boiler Dimensions

## Dimensions overview without bottom piping connections

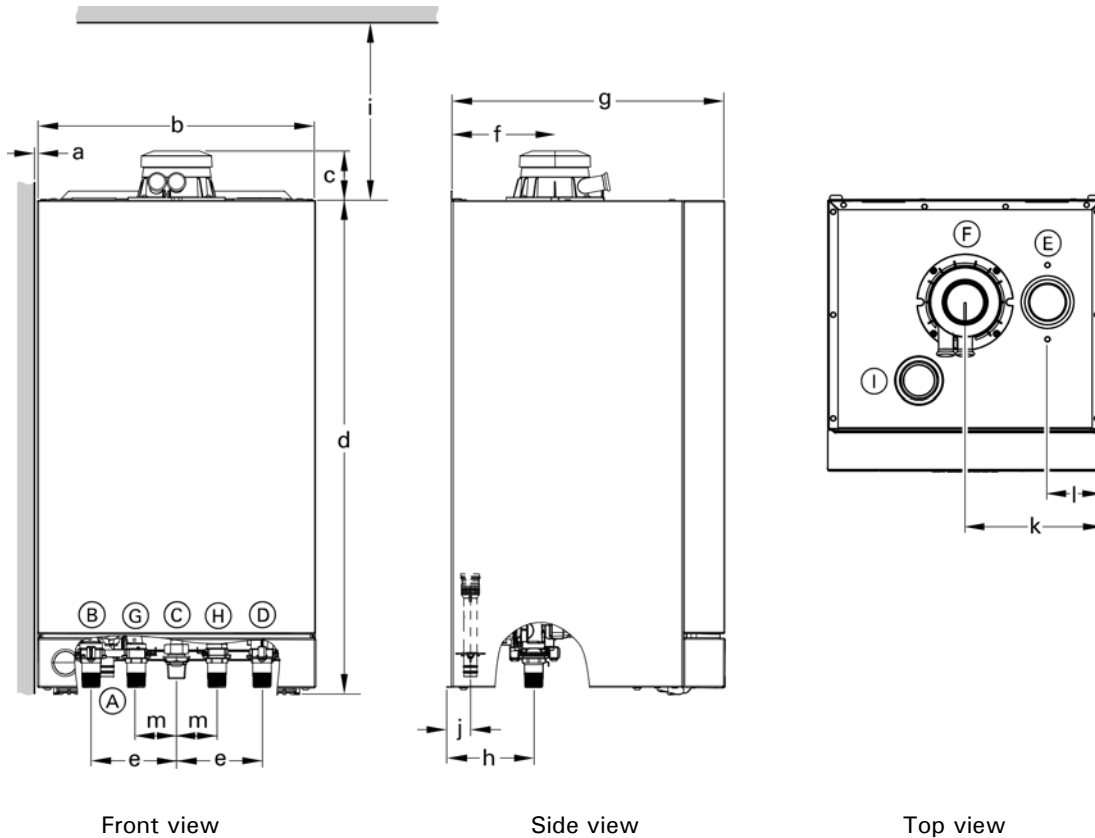

### Vitodens 100-W, B1HA series and B1KA combi

#### Legend

- (A) Condensate drain, plastic hose Ø 1 in. (Ø 22 mm)
- (B) Boiler water supply, NPT 3/4 in. (male thread)
- (C) Gas connection, NPT 3/4 in. (male thread)
- (D) Boiler water return, NPT 3/4 in. (male thread)
- (E) Combustion air opening for double pipe system
- (F) Combustion air opening for coaxial system/gas vent adaptor
- (G) - For B1HA series, DHW tank heating supply NPT 3/4 in. (male thread)  
- For B1KA combi, DHW, NPT 1/2 in. (male thread)
- (H) - For B1HA series, DHW tank heating return NPT 3/4 in. (male thread)  
- For B1KA combi, DCW, NPT 1/2 in. (male thread)
- (I) Opening for pressure relief valve



When preparing gas, water and electrical connections in the field, see section entitled "Boiler Mounting" on page 13 of this manual for information regarding the installation of the wall mounting bracket.

**Note:** The B1HA DHW supply and return connections are supplied capped. For installations that require DHW tank connections remove caps. For installations that do not require DHW tank connections leave caps installed.

#### Dimensions

- a 1/4 in. (5 mm) - both sides of the boiler
- b 15 3/4 in. (400 mm)
- c 2 5/8 in. (68 mm)
- d 27 1/2 in. (700 mm)
- e 4 7/8 in. (123 mm)
- f 6 in. (150 mm)
- g 15 3/4 in. (400 mm)
- h 5 in. (125 mm)
- i ≥ 9 3/8 in. (≥ 250 mm)
- j 1 1/8 in. (34 mm)
- k 7 7/8 in. (200 mm)
- l 3 1/8 in. (80 mm)
- m 2 1/4 in. (58 mm)

### IMPORTANT

The maximum ambient temperature must not exceed 104° F (40° C).

- Heating water connections, DHW tank connections (B) and (D), DCW (G) / DHW (H) (where applicable) and gas connection to be made in the field. See connection-specific section for details.
- See subsection entitled "Power supply connection" for details regarding power supply to the Vitodens 100-W boiler.

**Boiler Dimensions** *(continued)*

Piping connections for Vitodens 100-W,  
B1HA series and B1KA

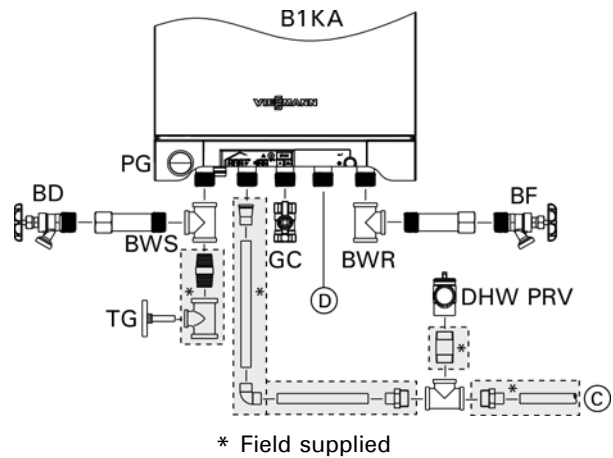
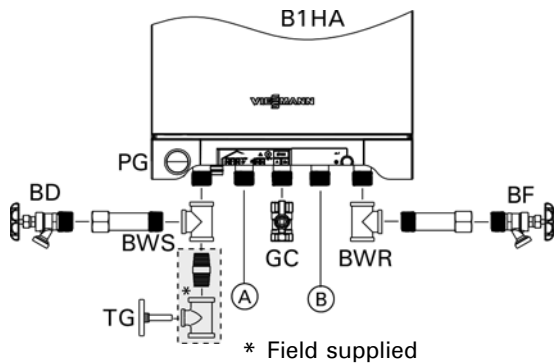
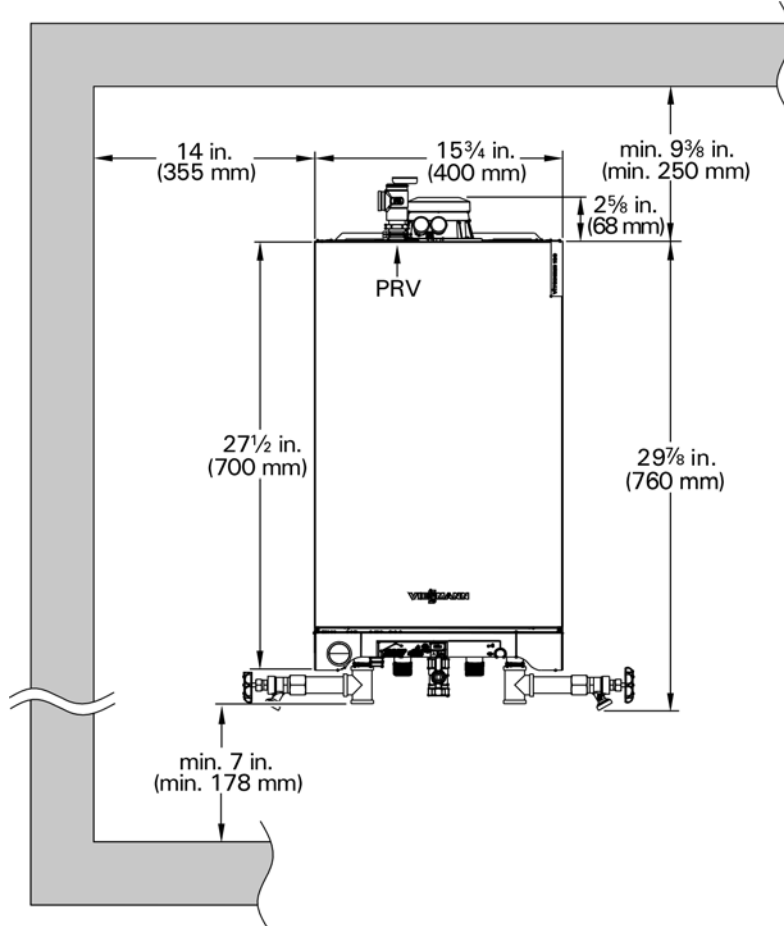

**Legend**

- (A) - DHW tank heating supply for B1HA boilers
- (B) - DHW tank heating return for B1HA boilers
- (C) - DHW for B1KA boiler
- (D) - DCW for B1KA boiler
- BWR Boiler water return
- BWS Boiler water supply
- BD Boiler drain
- BF Boiler fill
- GC Gas connection
- PRV Pressure relief valve
- PG Pressure gauge
- VC Venting connection
- TG Temperature gauge
- DHW PRV Domestic hot water pressure relief valve (150 psi)

**Note:** The B1HA DHW supply and return connections are supplied capped. For installations that require DHW tank connections remove caps. For installations that do not require DHW tank connections leave caps installed.

## Boiler Mounting

### Boiler installation

The Vitodens 100-W boiler can be wall-mounted on:

- a brick/concrete wall
- wood studs
- metal studs
- boiler stand

### Mounting Vitodens 100-W boiler

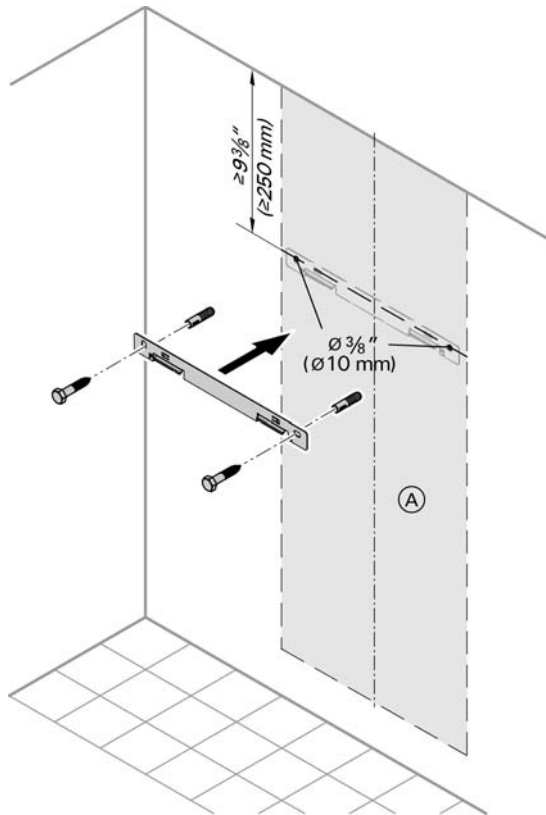

### Legend

- Ⓐ Boiler mounting

Following are the installation instructions for the mounting bracket on each material. Skip to the installation instructions applicable to your installation requirements.

### Installation of mounting bracket on brick/concrete wall:

1. Drill holes [ $\varnothing \frac{3}{8}$  in. (10 mm)].
2. Align wall mounting boiler bracket and attach to wall with the screws and plastic anchors supplied.



### CAUTION

Whichever mounting method is used, ensure that the boiler bracket is tightly and securely fastened to wall. Failure to secure the boiler properly could cause loosening, posing a severe safety hazard.

**Boiler Mounting** *(continued)*

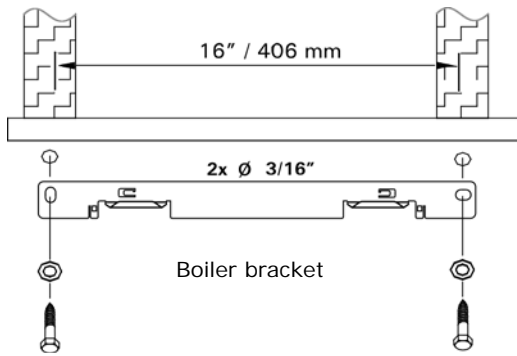

**Boiler mounting bracket installation on wood studs**

Install mounting bracket on wood studs as per illustration. Drill  $3/16$  in. pilot holes to insert mounting bolts. Ensure that holes are located in the center of each wood stud. Secure with bolts to wooden studs as shown.

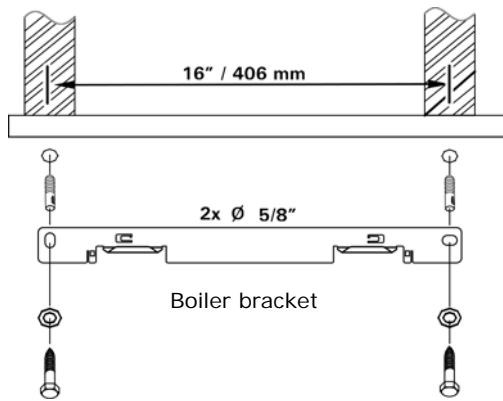
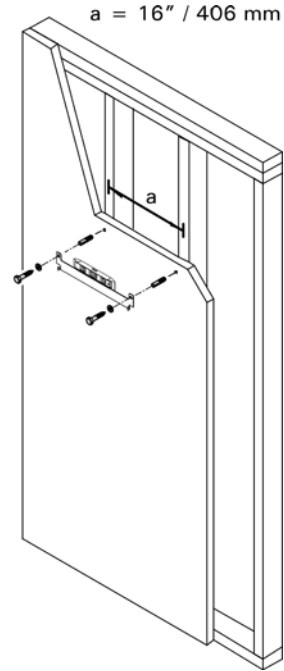

**Boiler mounting bracket installation on metal studs**

Install mounting bracket on metal studs as per illustration. Drill  $5/8$  in. pilot holes to insert anchors. Ensure that holes are located in the center of each metal stud. Use appropriate fasteners to mount boiler mounting bracket to metal studs (not supplied). Secure with bolts to metal studs as shown.

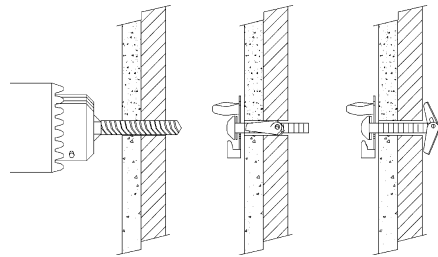

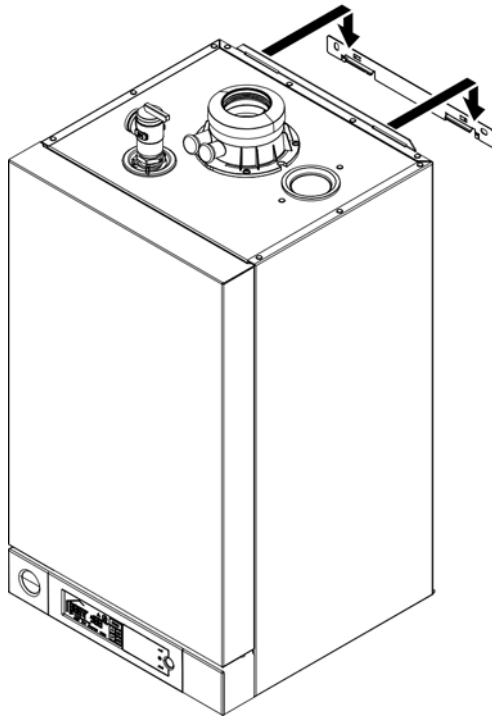
**Boiler Mounting** *(continued)***Mounting the boiler to the wall**

**Note:** Prior to installing the boiler verify that the minimum mounting clearances are met.

1. Mount boiler onto the mounting bracket, ensure the boiler is level.

**Boiler Mounting** *(continued)*

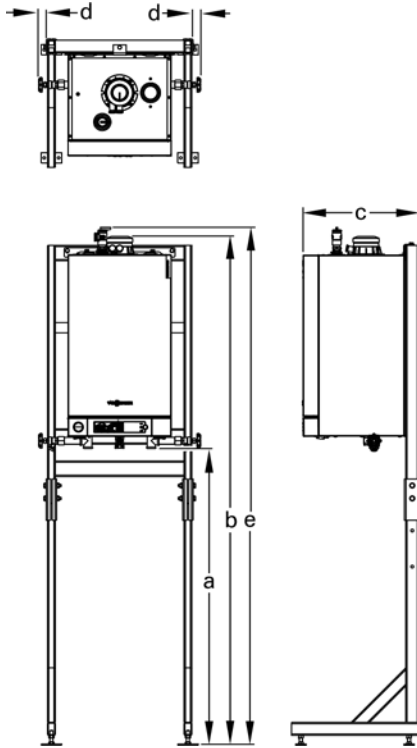

**Boiler mounting frame dimensions**

The boiler stand is used for free-standing installation of a single boiler within the mechanical room.

When using the boiler stand, ensure that the stand is securely fastened to the floor (recommended concrete expansion anchors are Hilti model KB-TZ 3/8 x 4 or equivalent).

The Vitodens 100-W, does not come with a mounting template. The wall location for the frame, mounting bracket and all vents must be field calculated.

Vitodens 100-W, B1HA 26, 35, B1KA 35		
a * 1	in. (mm)	45 5/8 (1160)
b * 1	in. (mm)	77 3/4 (1975)
c	in. (mm)	17 3/4 (450)
d	in. (mm)	1 1/4 (33)
e	in. (mm)	79 (2007)

\* 1 K 1/2 in. (12.7 mm) for adjustment of the levelling feet.

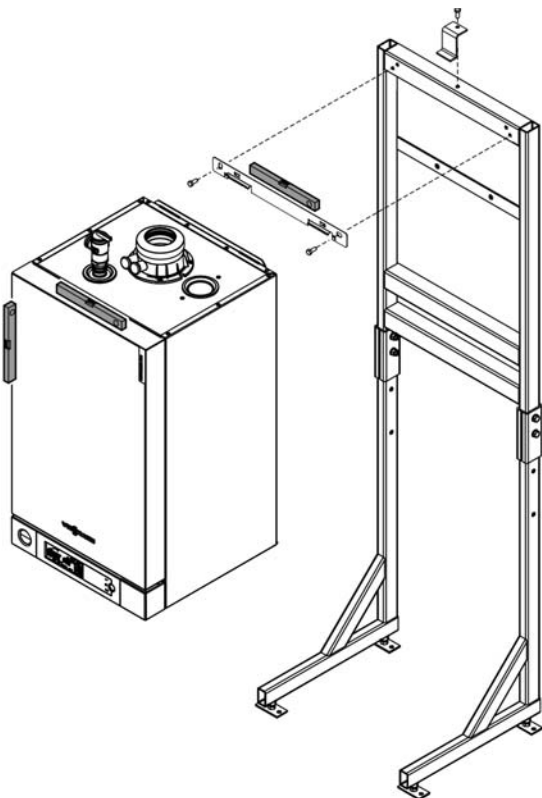

**Boiler mounting bracket and frame**

1. Attach the wall mounting bracket (supplied with the boiler) to the boiler mounting bracket frame using the supplied hardware. Ensure that the wall mounting bracket is level.
2. Move the rack into position and secure to the floor (and to the wall if needed).

**CAUTION**

The boiler must be level both vertically and horizontally to ensure proper draining of the condensate.



Refer to the single boiler rack Installation Instructions for more details.



## Boiler Connections

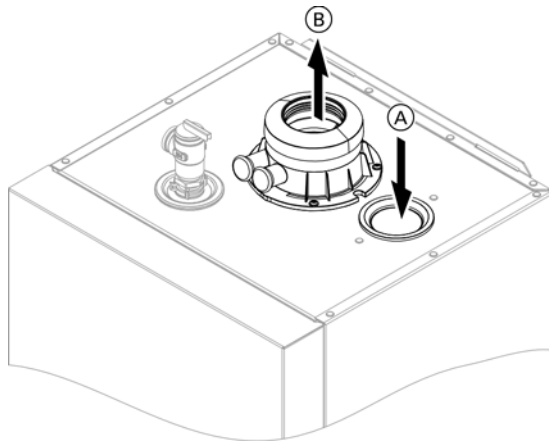

### Legend

- Ⓐ Combustion air inlet cover
- Ⓑ Flue gas vent adaptor

Coaxial combustion air inlet cover shown installed.  
 For coaxial venting system, remove the cover from the flue gas vent adaptor.

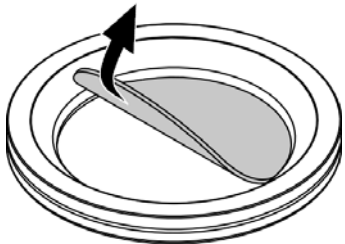

When utilizing the combustion air inlet cover Ⓐ for Vitodens 100-W series boilers, remove the center section and leave the rubber seal in place.

### Vent connections

The Vitodens 100-W boiler comes with a preinstalled vent pipe adaptor (as shown).  
 Run venting system, single-pipe, two-pipe or coaxial, through the side wall, roof or chimney, taking the shortest possible route and at a rising angle (min. 3°).



Refer to the Vitodens Venting System Installation Instructions.

**Boiler Connections** *(continued)*

2 imperfect threads

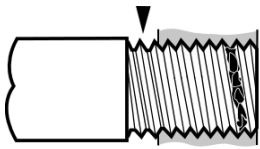

Use moderate amount of dope

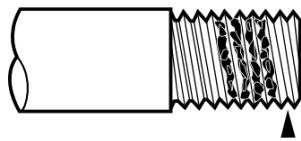

Leave 2 threads bare

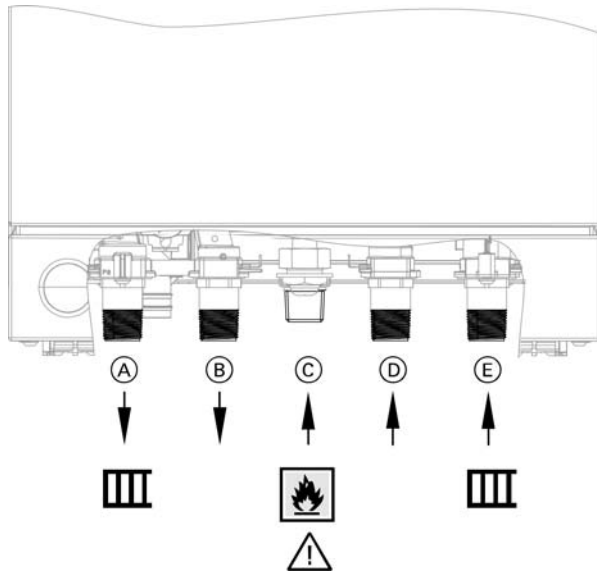
**Legend**

- Ⓐ Boiler water supply connection NPT 3/4 in. (male thread)
- Ⓑ DHW tank heating supply NPT 3/4 in. (male thread)  
(for B1HA) or DHW connection NPT 1/2 in. (male thread)  
(for B1KA)
- Ⓒ Gas connection NPT 3/4 in. (male thread)
- Ⓓ DHW tank heating return NPT 3/4 in. (male thread)  
(for B1HA) or DCW connection NPT 1/2 in. (male thread)  
(for B1KA)
- Ⓔ Boiler water return connection NPT 3/4 in. (male thread)

**Note:** The B1HA DHW supply and return connections are supplied capped. For installations that require DHW tank connections remove caps. For installations that do not require DHW tank connections leave caps installed.

**Proper piping practice**

Support piping by proper suspension method.  
Piping must not rest on or be supported by boiler.

**Gas connection and piping**

1. Make gas connection in accordance with codes CAN/CSA B149.1 or 2 in Canada. In the United States, use the National Fuel Gas Code ANSI Z223.1/NFPA 54, as well as local codes where applicable.
2. Close gas shutoff valve on boiler.
3. Perform leak test.
4. Bleed air from gas supply pipe.

See following page for details on gas connection and piping.

**Boiler Connections** *(continued)*

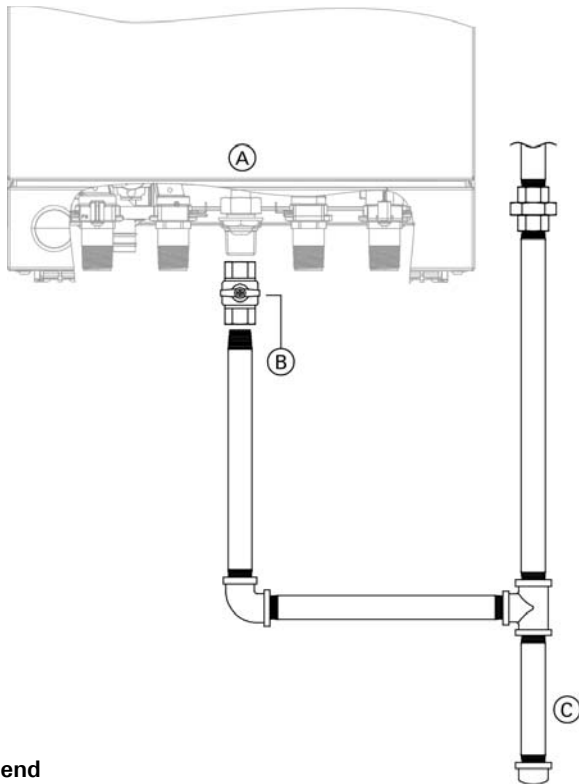

**Legend**

- (A) Gas connection
- (B) Accessible manual gas shutoff (factory supplied)
- (C) Drip leg

**IMPORTANT**

Max. gas supply pressure: 14 "w.c.  
 ½ psig = 14 "w.c.

**! WARNING**

Never check for gas leaks with an open flame.

**! WARNING**

Exposing boiler gas pressure regulator and gas valve to extreme pressures renders warranty null and void.

**Gas connection and piping** *(continued)*

1. Refer to current CAN/CSA B149.1 or 2 in Canada. In the United States, use the National Fuel Gas Code ANSI Z223.1/NFPA 54, as well as local codes for gas piping requirements and sizing. Pipe size to the boiler must be determined based on:
  - pipe length
  - number of fittings
  - maximum input requirements of all gas appliances in the residence.

**IMPORTANT**

**Design piping layout in such a way that piping does not interfere with serviceable components.**

2. Before connecting boiler to gas line, install ground joint union, capped drip leg and a manual equipment shutoff valve. Valves must be listed by a nationally recognized testing agency. Make boiler gas connection as shown on the left.

Gas connection (NPT).....Ø ¾ in.

3. Perform gas piping pressure test as described in the following subsection.
4. Identify shutoff valves as such with a tab and familiarize operator / ultimate owner of boiler with these valves.

**! WARNING**

The gas supply piping must be leak tested before placing the boiler in operation.

**! CAUTION**

Ensure that gas piping is large enough for all appliances in the residence. No noticeable gas pressure drop in the gas line must occur when any unit (or combination of units) lights or runs.

**Gas piping pressure test**

When performing the gas piping pressure test, ensure the following requirements are met.

1. Isolate the boiler from the gas supply piping system using the individual manual shutoff valve during pressure tests equal to or less than ½ psig (14 "w.c.)
2. The boiler and its individual shutoff valve must be disconnected from the gas supply piping system during any pressure testing of that system at test pressures in excess of ½ psig (14 "w.c.)
3. Perform leak test. Use approved liquid spray solution for bubble test. Ensure that no liquid is sprayed on any electrical components, wires or connectors. Do not allow leak detection fluid to contact gas valve regulator or regulator vent opening.
4. Correct any and all deficiencies.
5. Remove air from gas line.

**Boiler Connections** *(continued)*

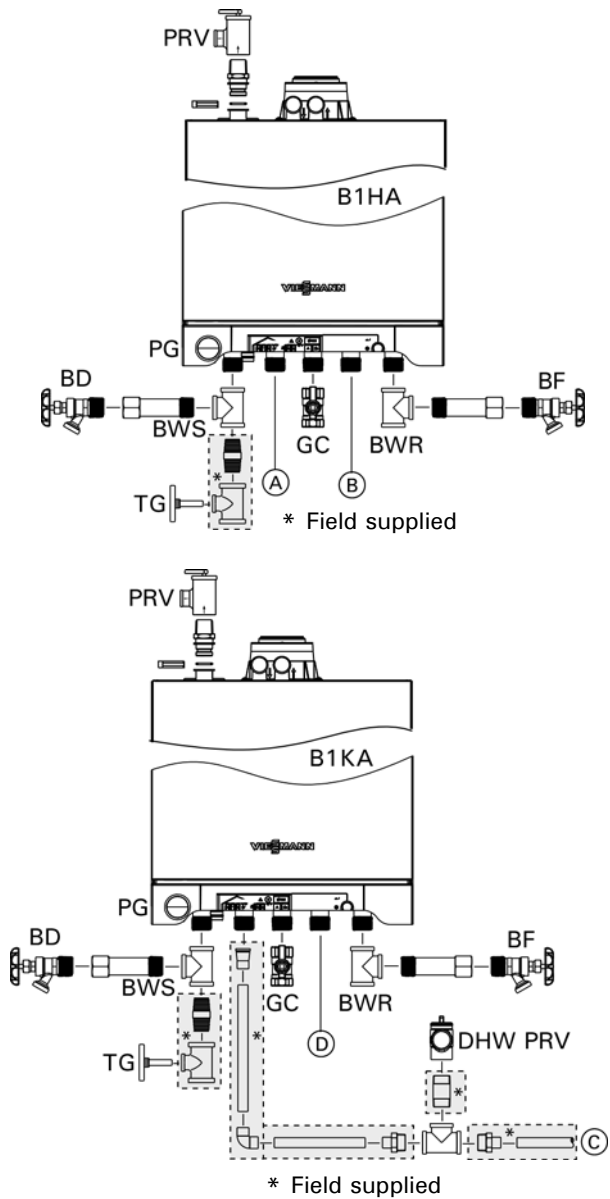

**Legend**

- (A) - DHW tank heating supply for B1HA boilers
- (B) - DHW tank heating return for B1HA boilers
- (C) - DHW for B1KA boiler
- (D) - DCW for B1KA boiler
- BWR Boiler water return
- BWS Boiler water supply
- BD Boiler drain
- BF Boiler fill
- GC Gas connection
- PRV Pressure relief valve
- PG Pressure gauge
- VC Venting connection
- TG Temperature gauge
- DHW PRV Domestic hot water pressure relief valve (150 psi)

**Heating water connections**

1. Thoroughly flush heating system (particularly before connecting the boiler to an existing system).
2. Connect boiler to the heating system.  
**Note:** Use an approved pipe sealant or teflon tape when connecting the installation fittings.

Max. operating pressure.....3 bar (45 psig)  
 Test pressure.....4 bar (60 psig)

**IMPORTANT**

**Damage resulting from pressure exceeding those values stated is not covered by Viessmann warranty.**

- Use a two-hand wrench method when tightening fittings or piping onto the boiler connectors. Use one wrench to prevent the boiler pipes from twisting and the second wrench to tighten the fitting or piping. Failure to support the boiler connection could damage the boiler and its internal piping.

**! WARNING**

**The pressure gage is a sensitive component and may be damaged if the boiler connections are not supported by using a second wrench when tightening fittings and/or piping.**

- All plumbing must meet or exceed all local state and national plumbing codes.

**IMPORTANT**

**SUPPORT ALL PIPING USING HANGERS. DO NOT support piping by the boiler or its components.**

- Use isolation valves to isolate system components.
- The B1HA DHW tank heating supply and return ports must remain capped if the DHW tank is not used.

**Note:** The B1HA DHW supply and return connections are supplied capped. For installations that require DHW tank connections remove caps. For installations that do not require DHW tank connections leave caps installed.

**Boiler Connections** *(continued)*

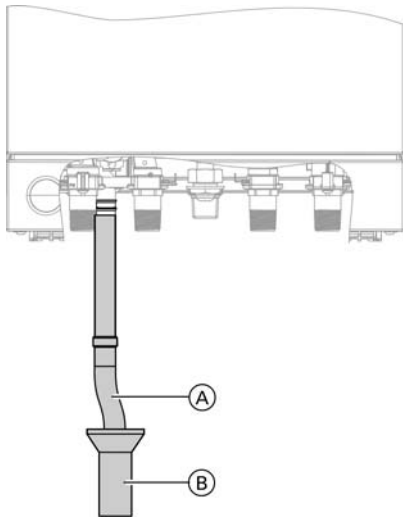

**Legend**

- (A) Flexible discharge tubing
- (B) Discharge tubing

**Condensate connection**

The Vitodens 100-W boiler comes with a built-in condensate trap. An external trap is not required when connecting the field drain to flexible discharge tubing. Discharge tubing (field supplied) must be of 1 in. diameter. Use CPVC, PVC or other material approved by codes listed below.

In the U.S. the drain pipe and fittings must conform to ANSI standards and ASTM D1785 or D2846. CPVC or PVC cement and primer must conform to ASTM D2564 or F493. In Canada use CSA or ULC listed schedule 40 CPVC or PVC drain pipe, fittings and cement.

If the condensate outlet of the Vitodens 100-W boiler is lower than the drain, a condensate pump must be installed. Select a pump which is approved for condensing boiler applications. To avoid condensate spillage, select a pump with an overflow switch. The drain connection must terminate into an open or vented drain as close to the boiler as possible to prevent siphoning of the boiler drain.

1. Install the condensate drain pipe with a suitable gradient.
2. Discharge condensate from the boiler into the drainage system, either directly or (if required) via a neutralization unit (accessory).



Installation Instructions of Neutralization Unit (if applicable)

**IMPORTANT**

Pipe ventilation must take place between the siphon trap and the neutralization unit (if applicable).

**IMPORTANT**

Do not connect the drain pipe from any other appliance, such as water softener backwash pipe, to Vitodens condensate drain pipe.

**Fill siphon with water**

Fill a minimum of 10 fl. oz. (0.3 liters) of water into the boiler adaptor.



**WARNING**

At initial start-up, flue gases may be emitted from the condensate drain. Fill the siphon with water before start-up.

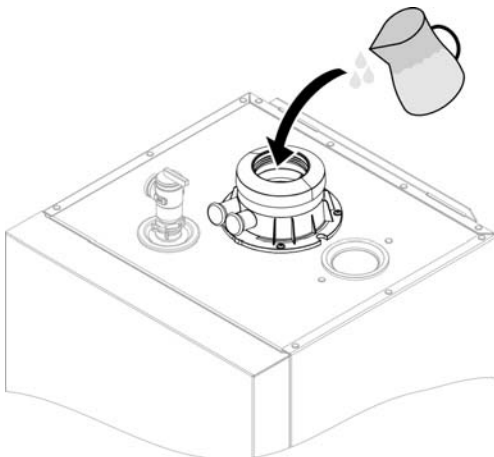

## Safety Connections and Pressure Testing

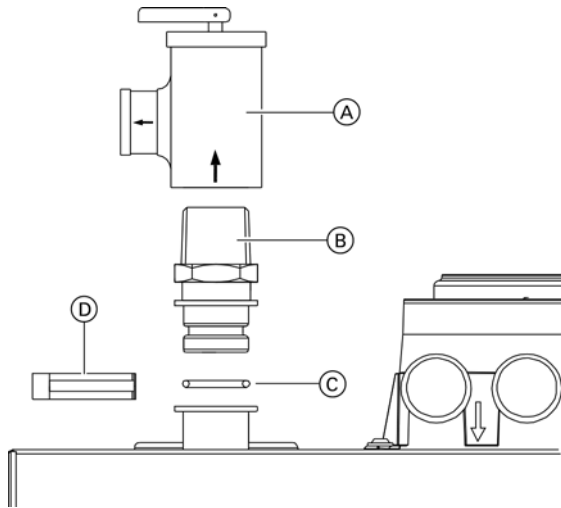

**Legend**

- Ⓐ Pressure relief valve
- Ⓑ Brass adaptor NPT
- Ⓒ O-ring
- Ⓓ Retaining clip

Minimum connection diameters:

Pressure relief valve..... 3/4 in.  
 Discharge pipe ..... 3/4 in.

### IMPORTANT

**Install the (approved) factory supplied pressure relief valve. Removal of air from the system must occur via use of air vent(s) in the system supply. To ensure the boiler can be purged of all air, ensure supply/return water lines do not contain restrictive piping where air could be trapped.**

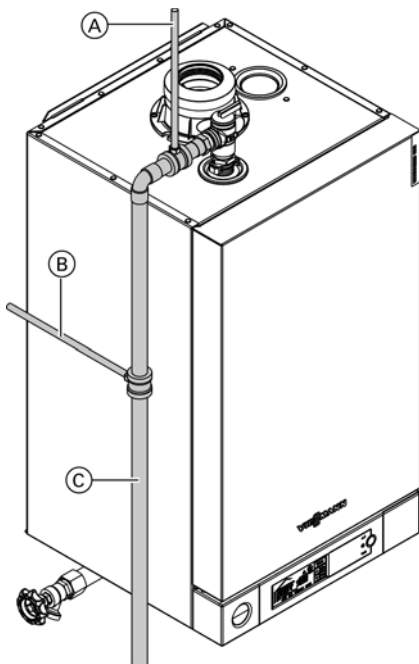

**Installing safety devices on the boiler**

1. Assemble the brass adaptor (Ⓑ), O-ring (Ⓒ), and retaining clip (Ⓓ) to the boiler.
  2. Apply sufficient amount of pipe sealant to adaptor (Ⓑ).
  3. Install pressure relief valve (Ⓐ) and tighten.
  4. Install discharge pipe on pressure relief valve in such a way that...
    - the end of the pipe is not threaded.
    - the pressure relief discharge pipe extends to a floor drain and ends approximately 6 in. (150 mm) above the drain.
- Ensure that...
- there is no shutoff valve installed in the discharge pipe.
  - discharge pipe diameter is not reduced.
  - discharge is not piped to outdoors.

**! WARNING**

**Do not install an isolation valve between boiler and pressure relief valve.**

**The discharge pipe for the pressure relief valve must be oriented to prevent scalding of attendants.**

**Pipe pressure relief valve discharge pipe close to floor drain. Never pipe discharge pipe to the outdoors.**

**Low water cut-off**

A low water cut-off may be required by local codes. Do not install an isolation valve between boiler and low water cutoff (see subsection entitled "Boiler with low water cutoff" on page 34 in these instructions).

**Pressure relief valve discharge pipe**

The pressure relief valve discharge pipe (Ⓒ) must be supported using either a ceiling mounted support (Ⓐ) or a wall mounted support (Ⓑ).

**Legend**

- Ⓐ Ceiling mounted support (field supplied)
- Ⓑ Wall mounted support (field supplied)
- Ⓒ Pressure relief valve discharge pipe (field supplied)

**Safety Connections and Pressure Testing** *(continued)*

**Hot water temperature and system pressure**

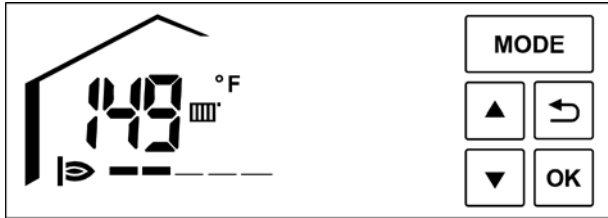

The boiler water temperature reading is constantly displayed during operation.

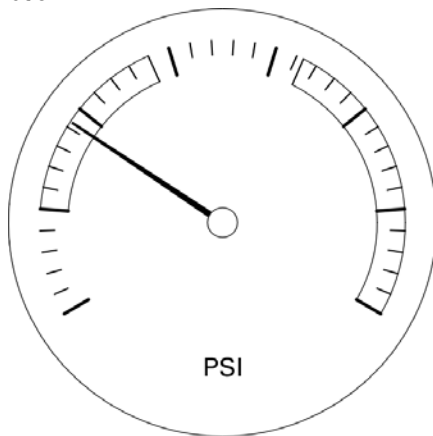

The boiler water pressure reading is displayed on an analog gauge.

**Performing pressure test on the boiler**

The boiler must be leak tested before being placed in operation. Before boiler is connected to piping or electrical power supply, it must be hydrostatically pressure tested.

1. Cap all supply and return connections (3/4 in. NPT).
2. Connect a 1/2 in. garden hose to boiler drain valve at the bottom of the boiler and fill boiler slowly until pressure gauge indicates max. 4 bar (60 psig).
3. Maintain pressure for 15 minutes. During time of pressure testing, do not leave boiler unattended.
4. Inspect all pipe joint connections and safety devices with a flashlight for leaks. A lower manometer reading than 4 bar (60 psig) usually indicates loss of water due to leakage. All leaks must be repaired.
5. After 15 minutes, release water pressure from boiler by opening boiler drain valve slowly, remove caps from supply and return connections as well as the 3/4 in. cap from pressure relief valve connection and install pressure relief valve immediately instead of 3/4 in. cap.

After boiler has passed the pressure test, proceed with the installation.

**! WARNING**

**Exposing the boiler to pressures and temperatures in excess of those listed will result in damage, and will render warranty null and void.**

See page 40 for fill procedure.

## Installation Examples

### General

The schematics on the following pages are to be seen as guidelines only. They further do not display all system varieties, safety devices, or concepts possible. Specific system layouts may be further discussed with the local Viessmann sales representative office.

### Clearances

A minimum of 2 in. (51 mm) circumferential clearance from non-insulated hot water pipes to combustible construction must be maintained. In cases where the pipes are insulated with pipe insulation of appropriate and sufficient thickness and insulation values, the above clearance may be reduced to 0" (refer to local gas codes).



### CAUTION

**For underfloor heating applications, an additional immersion or strap-on aquastat must be installed in the low temperature underfloor loop (downstream of the mixing valve) to de-energize the pump and/or boiler to prevent overheating. High water temperatures can damage concrete slabs.**

### Heating circuit pumps

Heating pumps with Vitodens 100-W are preinstalled.

- Grundfos 15-78 (factory set to speed 3)

Refer to the graphs on pages 25 and 26 for the proper waterside boiler friction loss calculations.

A low-loss header **must** be used when the **system** flow rate exceeds the maximum (or minimum) flow rate of the Vitodens 100-W boiler. An alternative method may be used, such as primary secondary piping using closely spaced tees.

A low-loss header offers additional benefits not provided by a pair of closely spaced tees. Viessmann strongly recommends and prefers the use of a low-loss header over closely spaced tees.

Use standard friction loss method for pipe sizing. Observe boiler maximum and minimum flow rate limitations. If system flow rate exceeds boiler maximum flow rate (as stated on page 25) or if system flow rate is unknown, Viessmann strongly recommends the installation of a low-loss header. See page 35 for low-loss header information or refer to the Vitodens Venting System Installation Instructions.

### IMPORTANT

**Pump selection must be based on accurate system flow and pressure drop calculations (including DHW sizing).**



## Installation Examples

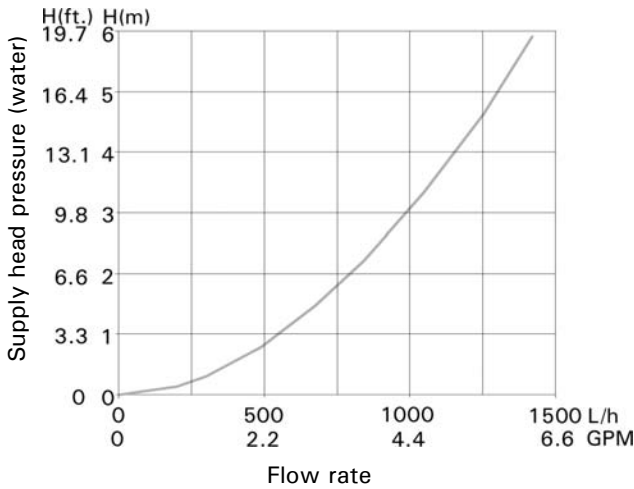

Pressure drop (primary circuit) for Vitodens 100-W, B1HA 26, 35 and B1KA 35  
 For sizing an on-site circulation system.  
 Max. flow rate: 6.2 GPM (1400 L/h)

### Waterside flow (primary circuit)

The Vitodens 100-W, B1HA/B1KA is designed for closed loop, forced circulation hot water heating systems only.

Use standard friction loss method for pipe sizing. Observe boiler maximum and minimum flow rate limitations. If system flow rate exceeds boiler maximum flow rate (as stated above), falls below the minimum flow rate or if system flow rate is unknown, Viessmann strongly recommends the installation of a low-loss header.

An alternative method may be used, such as primary secondary piping using closely spaced tees. A low-loss header offers additional benefits not provided by a pair of closely spaced tees. Viessmann therefore strongly recommends and prefers the use of a low-loss header over closely spaced tees. Refer to the Technical Data manual for low-loss header information.

Boiler maximum flow rate 6.2 GPM (1400 L/h)

Model B1HA 26		1 boiler
Output (NG/LPG)		
	MBH	88
$\Delta t$ for NG/LPG		
20°F (11°C) rise	GPM (L/h)	8.8 (1999)
25°F (14°C) rise	GPM (L/h)	7.0 (1599)
30°F (17°C) rise	GPM (L/h)	5.9 (1332)
35°F (19.5°C) rise	GPM (L/h)	5.0 (1142)
40°F (22°C) rise	GPM (L/h)	4.4 (999)

Boiler maximum flow rate 6.2 GPM (1400 L/h)

Model B1HA 35/B1KA 35		1 boiler
Output (NG/LPG)		
	MBH	117
$\Delta t$ for NG/LPG		
20°F (11°C) rise	GPM (L/h)	11.7 (2657)
25°F (14°C) rise	GPM (L/h)	9.4 (2126)
30°F (17°C) rise	GPM (L/h)	7.8 (1771)
35°F (19.5°C) rise	GPM (L/h)	6.7 (1518)
40°F (22°C) rise	GPM (L/h)	5.9 (1328)

**Installation Examples** *(continued)*

**Built-in pump**

Grundfos UPS15-78 three speed heating circuit/DHW production pump for Vitodens 100-W B1HA 26/35 and B1KA 35 boilers (in the factory setting, the pump speed is preset to 'speed three')

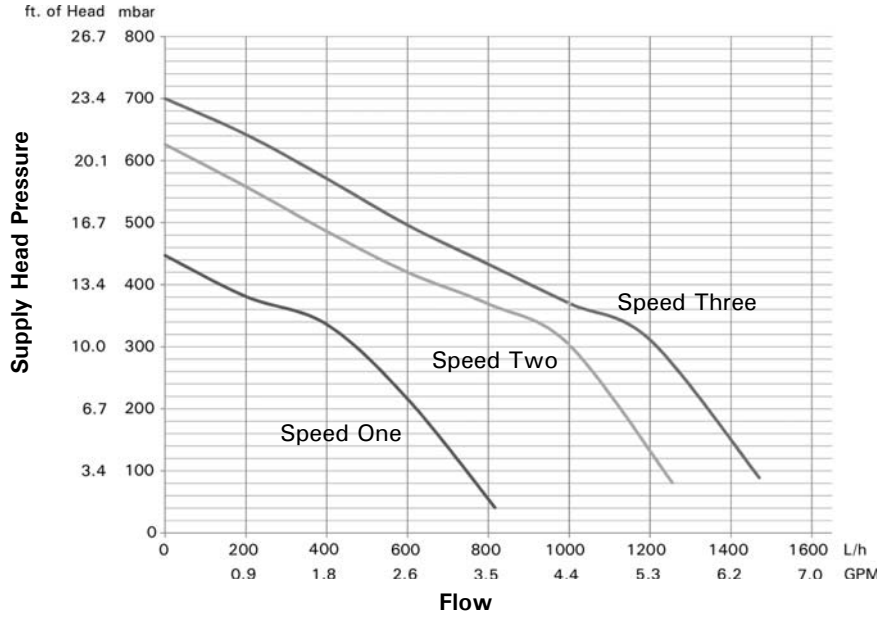

Pump Model	Grundfos UPS15-78	
Rated voltage	VAC	115
Rated current	A max.	1.15
	A min.	0.8
Capacitor	μF	8
Power consumption	W max.	130
	W min.	80

**Built-in pump, Grundfos UPS15-78 residual head pressure**

Residual head of built-in pump at speed 3 (factory set).

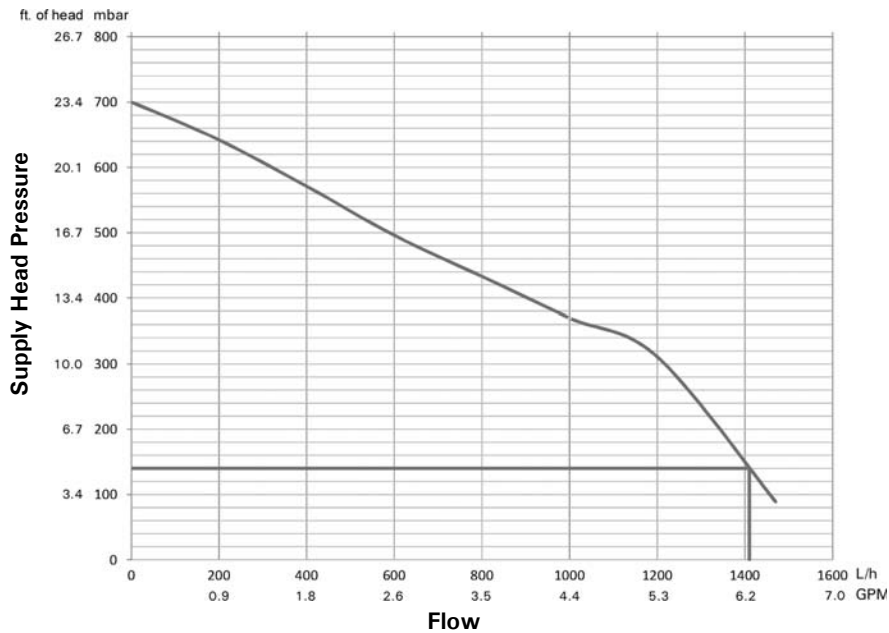

**Installation Examples** *(continued)*

Vitodens 100-W, B1HA 26, 35 with one heating circuit

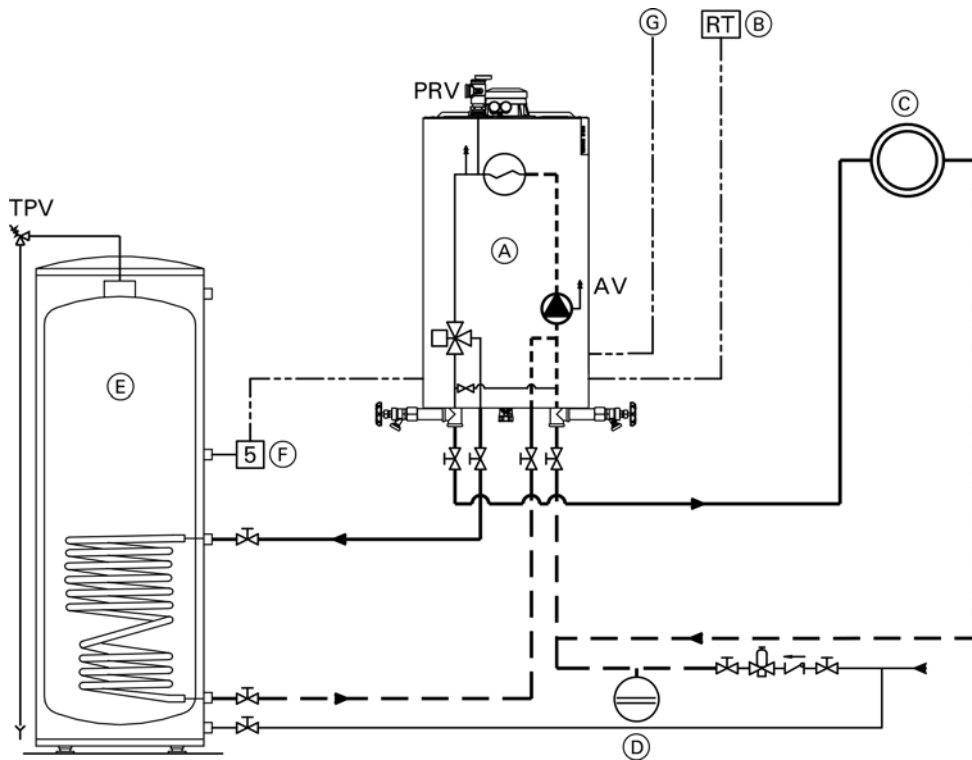

**Legend**

- AV Air vent
- PRV Pressure relief valve
- TPV Temperature and pressure relief valve
- (A) Vitodens 100-W
- (B) Room thermostat
- (C) Heating circuit
- (D) Expansion tank
- (E) DHW storage tank
- (F) DHW tank temperature sensor
- (G) Outdoor temperature sensor (OTS)

**Note:** The use of a low-loss header is recommended if the water flow rate is less than 1.7 GPM (400 L/h) or more than 6.2 GPM (1400 L/h).  
The low-loss header is available as accessory part.

**IMPORTANT**

Ensure that a pressure activated by-pass is installed if there are system component(s) in (C) that may isolate the flow to the pump.

**Maximum Flow Rates**

Model B1HA		26	35
Output	MBH	88	117
$\Delta t$			
30°F (17°C) rise	GPM (L/h)	5.9 (1332)	7.8 (1772)*
35°F (19.5°C) rise	GPM (L/h)	5.0 (1142)	6.7 (1522)*
40°F (22°C) rise	GPM (L/h)	4.4 (999)	5.9 (1328)

\* Requires low loss header or closely spaced tees.

**Installation Examples** *(continued)*

Vitodens 100-W, B1HA 26, 35 with...

- DHW storage tank
- low-loss header
- one heating circuit

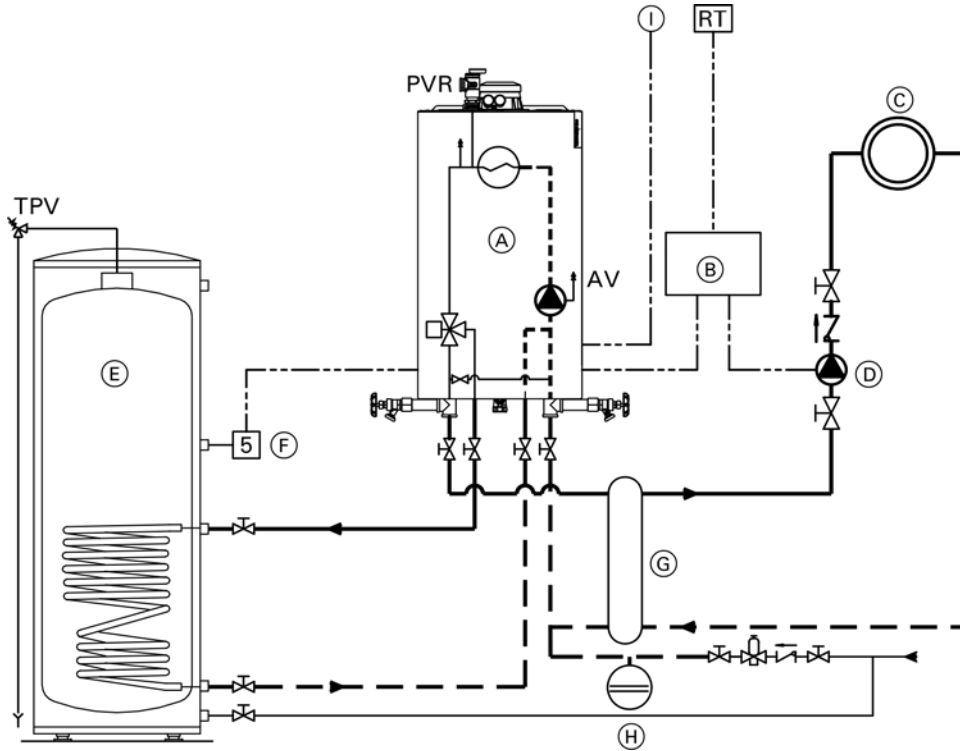

**Legend**

- AV Air vent
- PRV Pressure relief valve
- TPV Temperature and pressure relief valve
- (A) Vitodens 100-W gas-fired condensing boiler
- (B) External boiler controller with room thermostat connection (field supplied)
- (C) Heating circuit
- (D) Heating circuit pump (field supplied)
- (E) DHW storage tank
- (F) DHW tank temperature sensor
- (G) Low-loss header (there is no LLH temperature sensor available for the B1HA)
- (H) Expansion tank
- (I) Outdoor temperature sensor (OTS)

**Note:** The use of a low-loss header is recommended if the water flow rate is less than 1.7 GPM (400 L/h) or more than 6.2 GPM (1400 L/h). The low-loss header is available as accessory part.

**IMPORTANT**

DHW supply and return piping between boiler DHW connections and the Viessmann DHW tank connections, shall be a minimum of 1 in. nominal pipe diameter (irrespective of the 3/4 in. DHW connection outlet sizes provided on the boiler and the DHW tank).

This ensures that the head of the pump is fully utilized to overcome the resistance of the DHW heat exchanger coil and to provide sufficient water flow to the boiler heat exchanger.

In non-Viessmann DHW tank applications, perform, in addition to the above, accurate calculations for DHW tank coil pressure drop versus boiler pump head to ensure sufficient water flow to the boiler heat exchanger.

Failure to heed the above instructions may cause boiler short-cycling and inadequate DHW supply.

**Maximum Flow Rates**

Model B1HA		26	35
Output	MBH	88	117
$\Delta t$			
30°F (17°C) rise	GPM (L/h)	5.9 (1332)	7.8 (1772)*
35°F (19.5°C) rise	GPM (L/h)	5.0 (1142)	6.7 (1522)*
40°F (22°C) rise	GPM (L/h)	4.4 (999)	5.9 (1328)

\* Requires low loss header or closely spaced tees.

**Installation Examples** *(continued)*

Vitodens 100-W, B1HA 26, 35 with DHW storage tank and one heating circuit

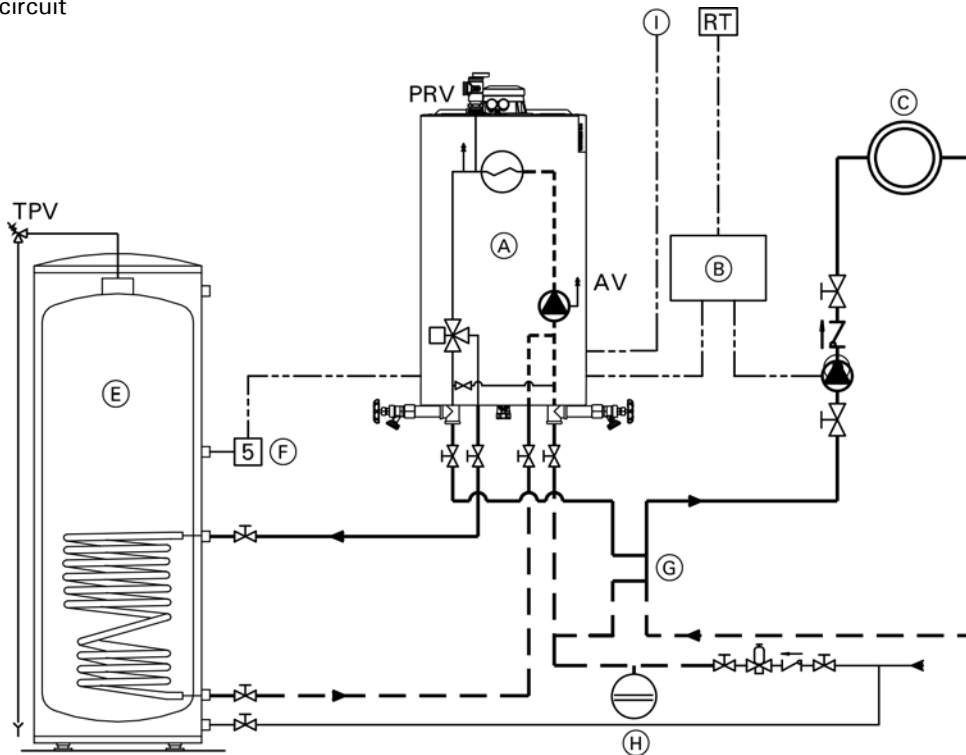

**Legend**

- AV Air vent
- PRV Pressure relief valve
- TPV Temperature and pressure relief valve
- (A) Vitodens 100-W gas-fired condensing boiler
- (B) External boiler controller (field supplied)
- (C) Heating circuit
- (D) Heating circuit pump with room thermostat connection (field supplied)
- (E) DHW storage tank
- (F) DHW tank temperature sensor
- (G) Closely spaced tees, 4x pipe Ø or 12 in. (305 mm)\*
- (H) Expansion tank
- (I) Outdoor temperature sensor (OTS)

\* A low-loss header offers additional benefits not provided by a pair of closely spaced tees. Viessmann strongly recommends and prefers the use of a low-loss header over closely spaced tees. See page 17 for details.

**Note:** The use of a low-loss header is recommended if the water flow rate is less than 1.7 GPM (400 L/h) or more than 6.2 GPM (1400 L/h). The low-loss header is available as an accessory part.

**IMPORTANT**

DHW supply and return piping between boiler DHW connections and the Viessmann DHW tank connections, shall be a minimum of 1 in. nominal pipe diameter (irrespective of the ¾ in. DHW connection outlet sizes provided on the boiler and the DHW tank).

This ensures that the head of the pump is fully utilized to overcome the resistance of the DHW heat exchanger coil and to provide sufficient water flow to the boiler heat exchanger.

In non-Viessmann DHW tank applications, perform, in addition to the above, accurate calculations for DHW tank coil pressure drop versus boiler pump head to ensure sufficient water flow to the boiler heat exchanger.

Failure to heed the above instructions may cause boiler short-cycling and inadequate DHW supply.

**Maximum Flow Rates**

Model B1HA		26	35
Output	MBH	88	117
Δ t			
30°F (17°C) rise	GPM (L/h)	5.9 (1332)	7.8 (1772)*
35°F (19.5°C) rise	GPM (L/h)	5.0 (1142)	6.7 (1522)*
40°F (22°C) rise	GPM (L/h)	4.4 (999)	5.9 (1328)

\* Requires low loss header or closely spaced tees.

**Installation Examples** *(continued)*

Vitodens 100-W, B1KA 35 with one heating circuit

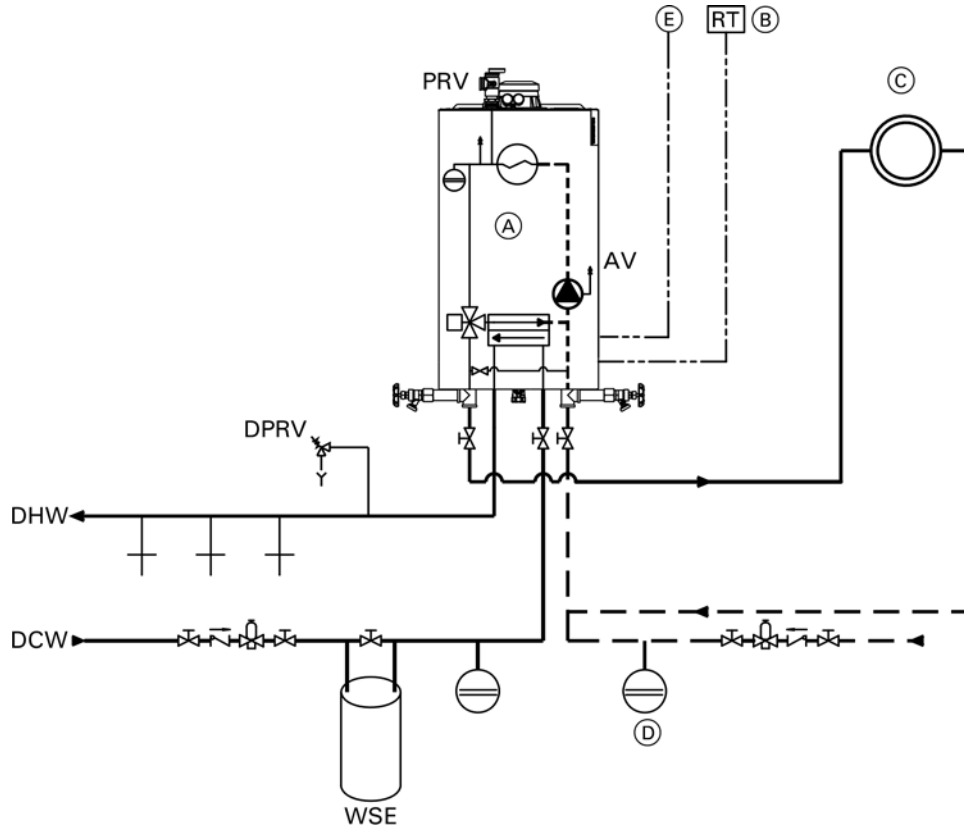

**Legend**

- AV Air vent
- PRV Pressure relief valve (boiler)
- DPRV Pressure relief valve (DHW 150 psi)
- WSE Water softener equipment
- DHW Domestic hot water
- DCW Domestic cold water
- (A) Vitodens 100-W
- (B) Room thermostat
- (C) Heating circuit
- (D) Expansion tank
- (E) Outdoor temperature sensor (OTS)

**Note:** The use of a low-loss header is recommended if the water flow rate is less than 1.7 GPM (400 L/h) or more than 6.2 GPM (1400 L/h). The low-loss header is available as accessory part.

Built-in pump residual head for the heating system side is 4.3 ft. of water column at the boiler maximum flow rate of 6.2 GPM.

**Maximum Flow Rates**

Model B1KA		35
Output	MBH	117
$\Delta t$		
30°F (17°C) rise	GPM (L/h)	7.8 (1772)*
35°F (19.5°C) rise	GPM (L/h)	6.7 (1522)*
40°F (22°C) rise	GPM (L/h)	5.9 (1328)

\* Requires low loss header or closely spaced tees.

**Installation Examples** *(continued)*

Vitodens 100-W, B1KA 35 with...

- low-loss header
- one heating circuit

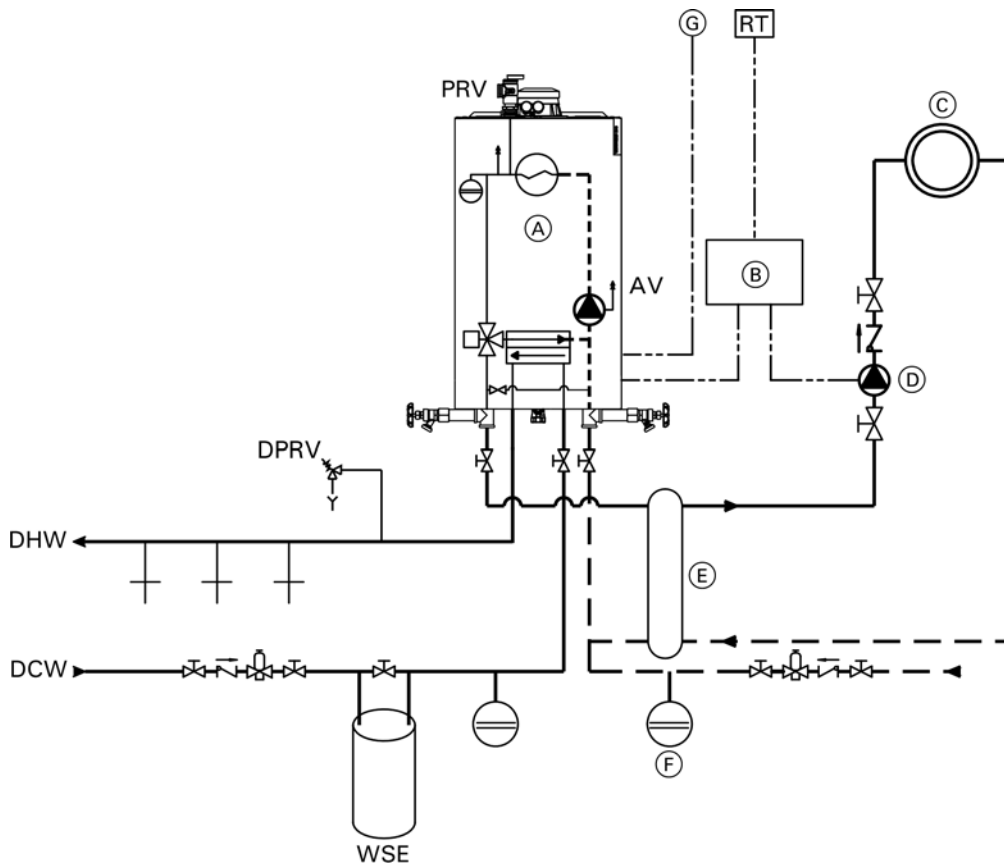

**Legend**

- AV Air vent
- PRV Pressure relief valve (boiler)
- DPRV Pressure relief valve (DHW 150 psi)
- WSE Water softener equipment
- DHW Domestic hot water
- DCW Domestic cold water
- (A) Vitodens 100-W gas-fired condensing boiler
- (B) External boiler / system controller with room thermostat connection (field supplied)
- (C) Heating circuit
- (D) Heating circuit pump (field supplied)
- (E) Low-loss header (there is no LLH temperature sensor available for the B1KA)
- (F) Expansion tank
- (G) Outdoor temperature sensor (OTS)

**Note:** The use of a low-loss header is recommended if the water flow rate is less than 1.7 GPM (400 L/h) or more than 6.2 GPM (1400 L/h).  
The low-loss header is available as accessory part.

**Maximum Flow Rates**

Model B1KA		35
Output	MBH	117
$\Delta t$		
30°F (17°C) rise	GPM (L/h)	7.8 (1772)*
35°F (19.5°C) rise	GPM (L/h)	6.7 (1522)*
40°F (22°C) rise	GPM (L/h)	5.9 (1328)

\* Requires low loss header or closely spaced tees.

**Installation Examples** *(continued)*

Vitodens 100-W, B1KA 35 with one heating circuit without LLH

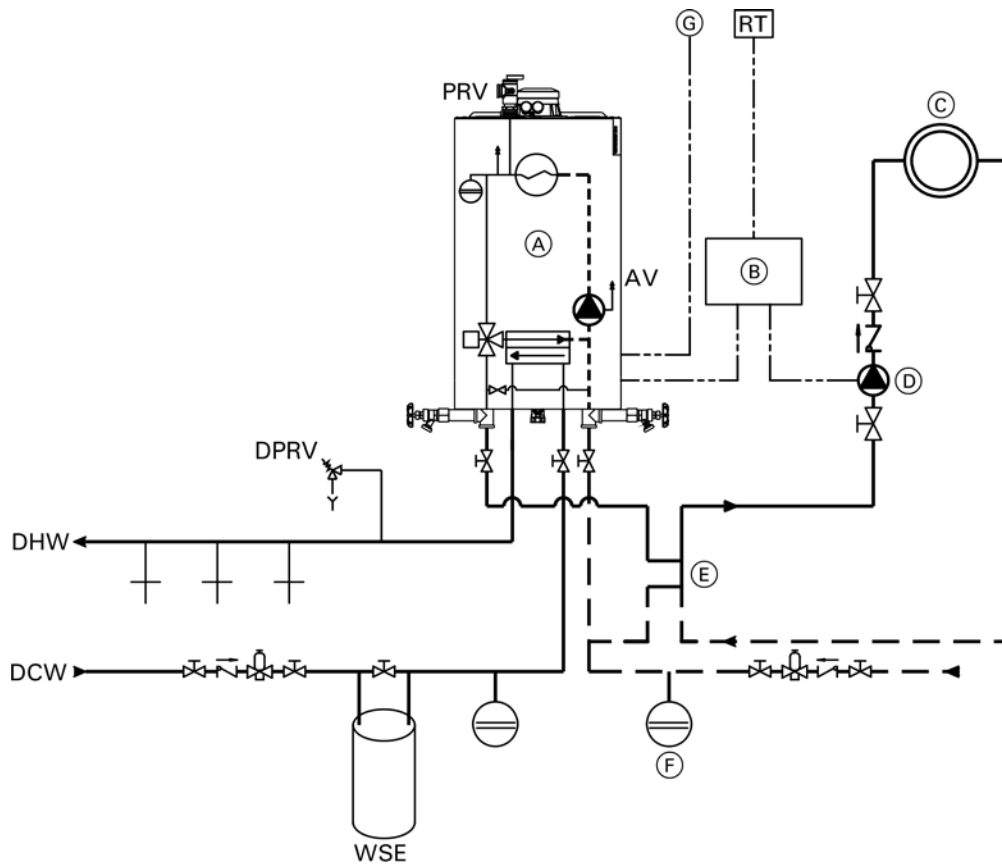

**Legend**

- AV Air vent
- PRV Pressure relief valve (boiler)
- DPRV Pressure relief valve (DHW 150 psi)
- WSE Water softener equipment
- DHW Domestic hot water
- DCW Domestic cold water
- (A) Vitodens 100-W gas-fired condensing boiler
- (B) External system controller (field supplied)
- (C) Heating circuit
- (D) Heating circuit pump with room thermostat connection (field supplied)
- (E) Closely spaced tees, 4x pipe Ø or 12 in. (305 mm) \* 1
- (F) Expansion tank
- (G) Outdoor temperature sensor (OTS)

\* 1 A low-loss header offers additional benefits not provided by a pair of closely spaced tees. Viessmann strongly recommends and prefers the use of a low-loss header over closely spaced tees. See page 17 for details.

**Note:** The use of a low-loss header is recommended if the water flow rate is less than 1.7 GPM (400 L/h) or more than 6.2 GPM (1400 L/h). The low-loss header is available as an accessory part.

**Maximum Flow Rates**

Model B1KA		35
Output	MBH	117
Δ t		
30°F (17°C) rise	GPM (L/h)	7.8 (1772)*
35°F (19.5°C) rise	GPM (L/h)	6.7 (1522)*
40°F (22°C) rise	GPM (L/h)	5.9 (1328)

\* Requires low loss header or closely spaced tees.



**Installation Examples** *(continued)*

**Boiler in heating/cooling application**

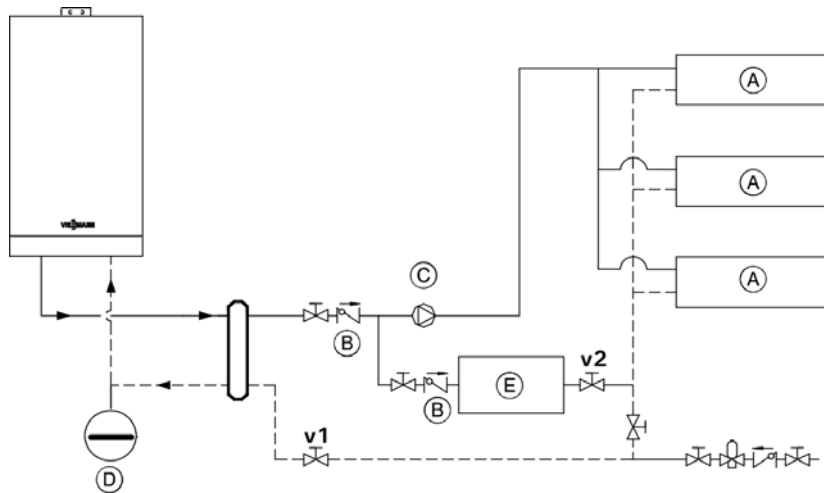

**Legend**

- Ⓐ Heating/Cooling unit
- Ⓑ Spring-loaded flow check valve
- Ⓒ Circulation pump
- Ⓓ Expansion tank
- Ⓔ Water chiller

**IMPORTANT**

**Viessmann strongly suggests that the valves pictured above be labelled "v1" and "v2".**

The boiler, when used in connection with a refrigeration system, must be installed ensuring the chilled medium is piped in parallel to the boiler with appropriate valves to prevent the chilled medium from entering the boiler.

The boiler piping system of a hot water heating boiler connected to heating coils located in air handling units where they may be exposed to refrigerated air circulation must be equipped with flow control valves or other automatic means to prevent gravity circulation of the boiler water during the cooling cycle.

Check installation instructions of the chiller manufacturer carefully for additional requirements.

**Cooling season starts:**

Close valve v1 and open valve v2.

**Heating season starts:**

Close valve v2 and open valve v1.

**Installation Examples** *(continued)*

**Boiler with low water cut-off (remote-mounted, field supplied)**

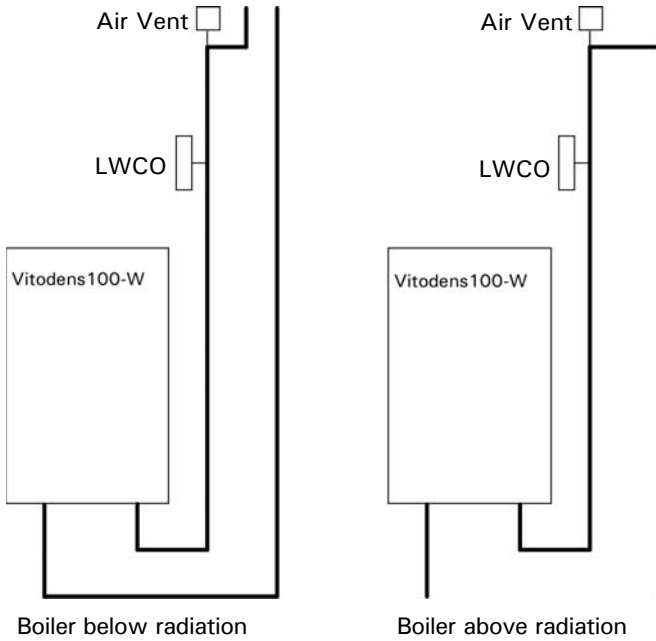

A low water cut-off may be required by local codes. Do not install an isolation valve between boiler and low water cut-off.

Follow the installation instructions of the low water cut-off manufacturer.

For low water cut-off wiring information specific to your application, refer to applicable wiring diagram on the boiler front panel.

**Note:** The Vitodens 100-W boiler has a built-in flow switch, which may be accepted by local codes in lieu of a low water cut-off.

**Venting**

**CAUTION**

Under certain climatic conditions some building materials may be affected by flue products expelled in close proximity to unprotected surfaces. Sealing or shielding of the exposed surfaces with a corrosion resistant material (e.g. aluminum sheeting) may be required to prevent staining or deterioration. The protective material should be attached and sealed (if necessary) to the building before attaching the vent termination. It is strongly recommended to install the vent termination on the leeward side of the building.



For detailed installation information and specific venting requirements, reference the Vitodens Venting System Installation Instructions supplied with the boiler.

# Neutralization Unit

## Accessories for the Vitodens 100-W

Neutralization Unit for Single-Boiler Applications with neutralizing granulate for Vitodens 100-W, B1HA 26, 35 and B1KA 35  
Part No. 7134 231

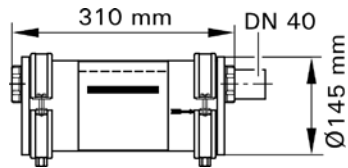

### Low-Loss Header

- Type 80/60 [max. flow rate 19.5 GPM (4.4 m<sup>3</sup>/h)]
- Type 120/80 [max. flow rate 35.2 GPM (8 m<sup>3</sup>/h)]

A low-loss header offers additional benefits not provided by a pair of closely spaced tees. Viessmann strongly recommends and prefers the use of a low-loss header over closely spaced tees. When used in conjunction with the Vitodens 100-W boiler, the low-loss header acts as hydraulic break, decoupling boiler and system circuits from each other (no sensor required). It is recommended to use the low-loss header in applications in which the total system flow rate exceeds the maximum or falls below the minimum flow rate of the Vitodens 100-W boiler.

For maximum boiler flow rates, see the table on page 25 in this manual.

Viessmann strongly recommends the use of a low-loss header in cases where the system head and flow rates are unknown.

In addition, the low-loss header helps eliminate air and debris [D] from the heating system. See illustrations for Low-loss header design and the principle of operation.

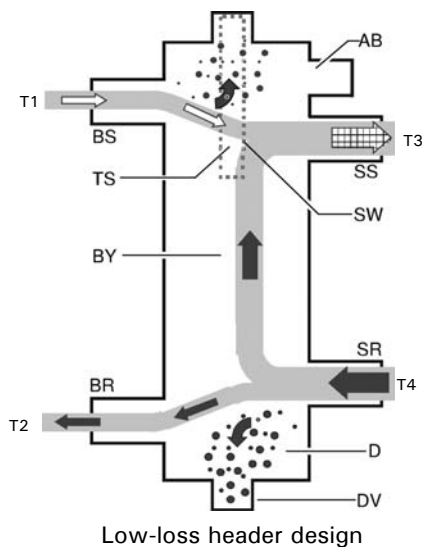

Low-loss header design

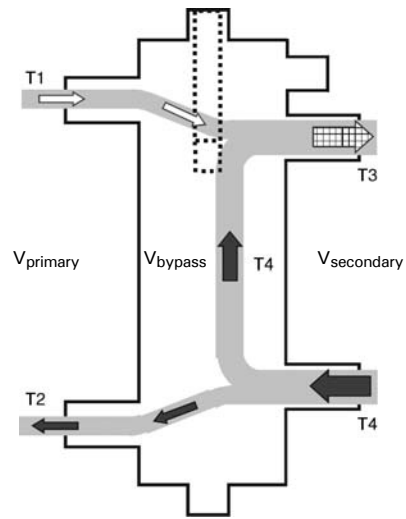

Principal of operation

The low-loss header is available in the following sizes. Select the size based on the maximum system flow rate of your application.

Model No.	Max. system flow rate
Type 80/60	19.5 GPM (4.4 m <sup>3</sup> /h)
Type 120/80	35.2 GPM (8 m <sup>3</sup> /h)

### Legend

AB	Air Bleed	DV	Drain Valve
BR	Boiler Return	SR	System Return
BS	Boiler Supply	SS	System Supply
BY	Bypass (with laminar flow)	TS	Viessmann Temp. Sensor (not used)
D	Debris and/or air	SW	Sensor Well
T1	Boiler supply temp.	T3	System supply temp.
T2	Boiler return temp.	T4	System return temp.

- $V_{primary}$  Boiler circuit flow rate
- $V_{secondary}$  Heating circuit flow rate
- $V_{bypass}$  Bypass flow rate
- $Q_{primary}$  Heat supplied by boiler
- $Q_{secondary}$  Heat consumed by system

$$V_{primary} < V_{secondary}$$

$$T1 > T3$$

$$T2 = T4$$

$$Q_{primary} = Q_{secondary}$$

$$T1 \text{ } 176^{\circ}\text{F (}80^{\circ}\text{C)}$$

$$V_{secondary} = V_{primary} + V_{bypass}$$

## IMPORTANT

When installing a low-loss header, system mixed supply temperature (T3) must be calculated as follows

$$T3 = \frac{T1 \times V_{primary} + T4 \times V_{bypass}}{V_{secondary}}$$

## Accessing Electrical Connections

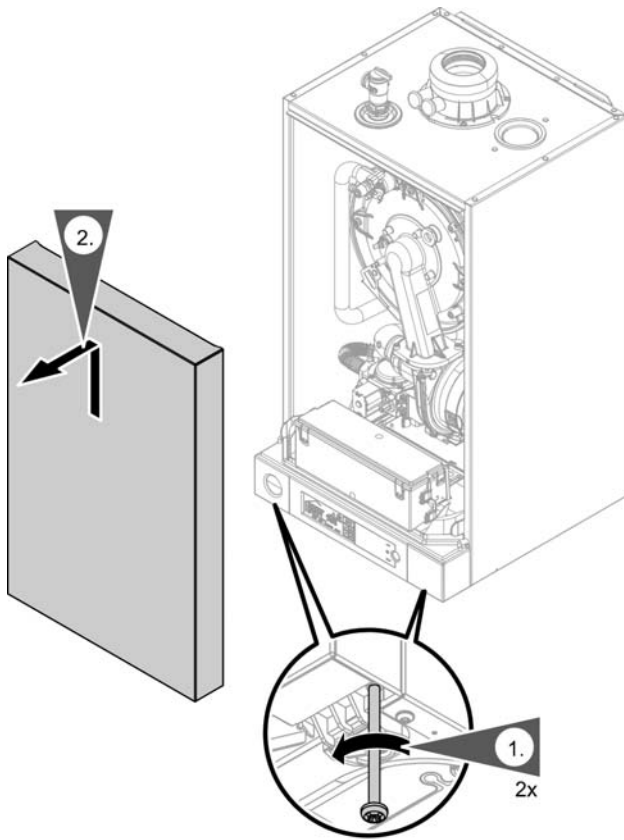

### Removing the front cover

1. Loosen retaining screws, screws are captive and do not need to be fully removed.
2. Remove the front panel.

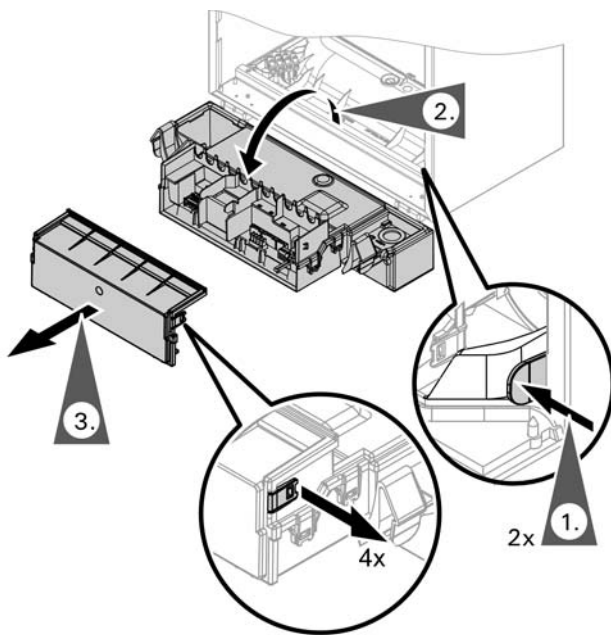

### Rotating the control unit and opening the power/pump module

1. Press in the control retaining tabs.
2. With retaining tabs pressed in rotate the control forward and down.
3. Release the 4 boiler cover retaining clips and pull cover off.

**Accessing Electrical Connections** *(continued)*

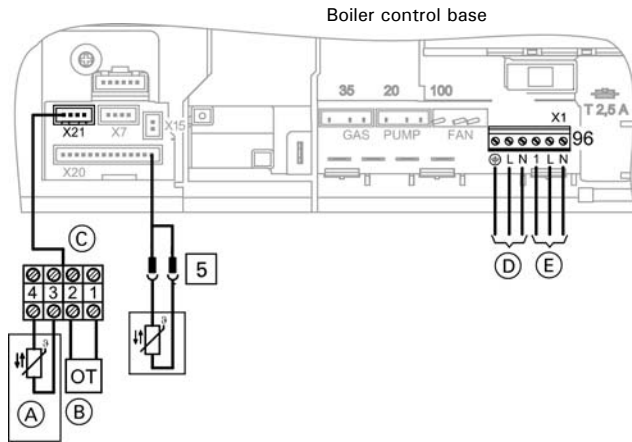

**Legend**

- (A) Viessmann outdoor temperature sensor (OTS) (field wiring)
- (B) OpenTherm (OT) 0-10V (field wiring)
- (C) Connection cable terminal
- (D) Power supply
- (E) Accessories 120VAC\*
- 5 DHW tank temperature sensor or aquastat (field supplied) (B1HA only)

\* When using the operating methods 'operation without room temperature thermostat' or 'weather compensated operation without room temperature thermostat' a jumper must be installed on terminal 96, refer to page 64.

**Optional operating control - OpenTherm (OT)**

**What is OpenTherm (OT)?**

The OpenTherm (OT) protocol is a point-to-point communication system, which connects a boiler with a room controller or other devices. The room temperature feedback calculates a heating demand (water temperature request) and transmits it to the boiler. The boiler will adjust the heat input accordingly (low-high modulation).

Follow the installation instructions of the field supplied operating controls.

**5 B1HA:**

- For Viessmann DHW tanks: Tank temperature sensor (plug on the cable harness outside the control unit - red connectors labelled "5").
- Operation without DHW tank: Set the set DHW temperature to "OFF".

**Note:** When connecting accessories observe the separate installation instructions provided with them.



Refer to the Operating Instructions.

**Room thermostat connection OpenTherm (OT)**

24VAC thermostats require a field supplied switching relay to OT connection (ie Taco SR501 or Honeywell RA889A-1001)

Connect Room Thermostat (Dry Contact) to OT connection

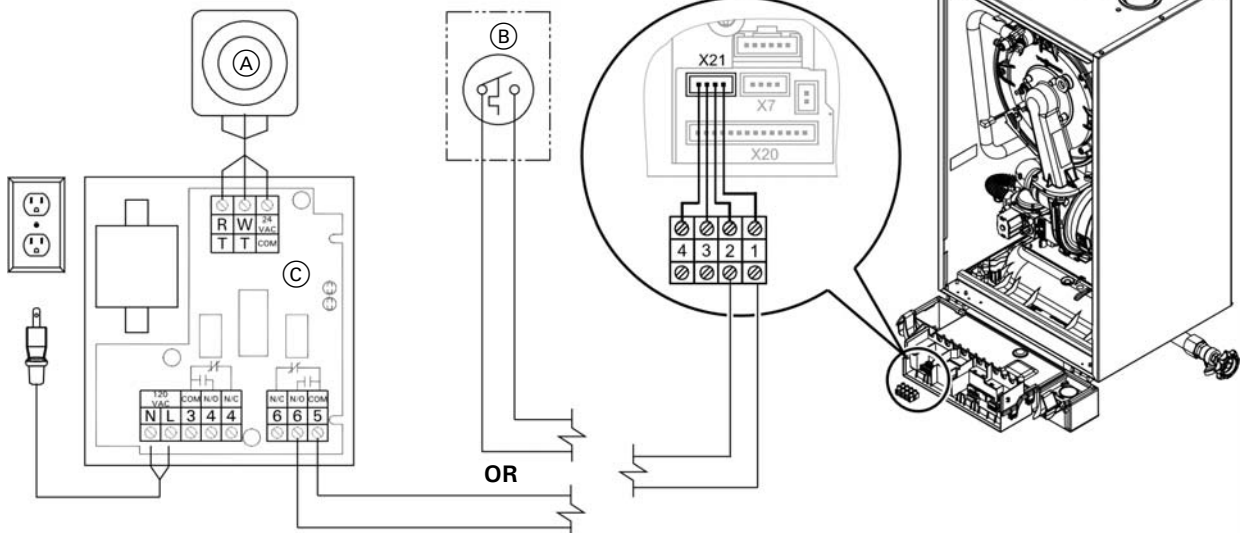

**Legend**

- (A) Room thermostat (24VAC)
- (B) Room thermostat (dry contact)
- (C) Switching relay

5784 568 - 02

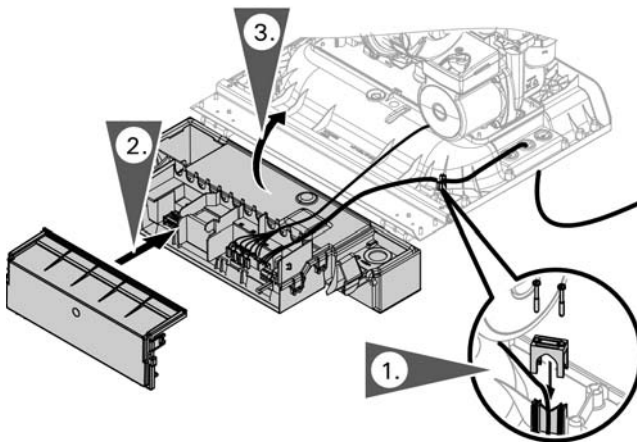
**Accessing Electrical Connections** *(continued)***Closing the control unit**

1. Connect the electrical accessories as per project design.
2. Secure all cables with strain reliefs.
3. Flip control upward and lock into position.

**CAUTION**

Electrical cables may become damaged if in contact with hot components. When running and securing connecting cables on site, ensure that the maximum permissible temperatures of the cables are not exceeded.

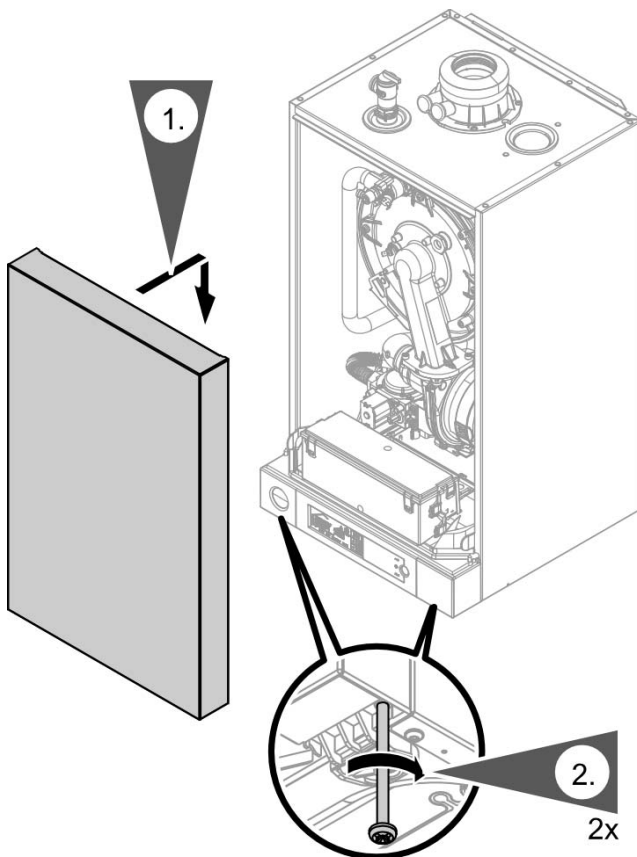
**Reinstalling the front panel**

1. Set front panel on the guide rails and push in place.
2. Tighten screws at the bottom.

**IMPORTANT**

Read and follow, where applicable, the safety instructions of all labels and stickers attached to boiler surfaces. Do not remove any of these instructions. Contact Viessmann if any replacement labels are required.

## Necessary Tools

### Testing/analysis equipment (use only calibrated equipment)

- Multimeter to measure 0 - 12A, 120V and  $\Omega$  resistances
- Flue gas analyzer to measure % CO<sub>2</sub> or O<sub>2</sub> (i.e. Bacharach fluid samplers or suitable electronic flue gas analyzer)
- Manometer to measure gas pressure 0 to 11 "w.c. (accurately) and up to 28 "w.c. gas pressure (or a non-electric Magnehelic® manometer may also be utilized)
- Stack thermometer 0 to 500°F (0 to 260°C)
- Carbon monoxide measuring equipment 0 to 400 ppm.

### Special items

- Approved leak detection fluid for natural gas
- Pipe joint sealant
- Garden hose for bleeding boiler heat exchanger and pressure testing

### Cleaning supplies

- Plastic hand brush
- Rags

## Overview of Controls and Indicators

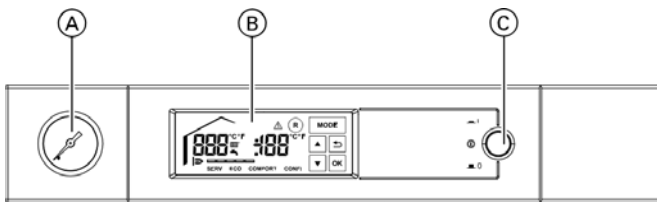

### Legend

- Ⓐ Pressure gage
- Ⓑ LCD display unit
- Ⓒ Power switch ON/OFF

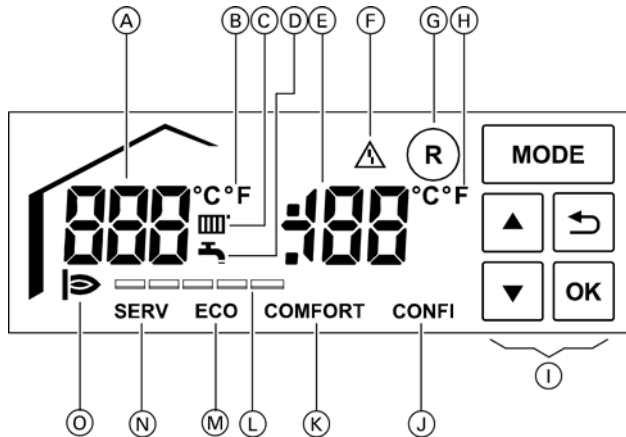

### Control and display elements

The control unit is preset at the factory for standard operation. Your heating system is ready for use. The factory presets may be individually adjusted to suit your specific requirements.

### Legend

- Ⓐ Display value or "F" (fault)
- Ⓑ Temperature in °F/°C (in conjunction with the display value)
- Ⓒ Heating mode
- Ⓓ DHW heating
- Ⓔ Display value or fault code
- Ⓕ Fault indicator
- Ⓖ Burner fault reset
- Ⓗ Temperature in °F/°C (in conjunction with the display value)
- Ⓘ On-screen buttons
- Ⓙ Commissioning setting active (contractors only)
- Ⓚ DHW comfort function active (only for B1KA)
- Ⓛ Current burner output (each bar = 20% \*)
- Ⓜ DHW comfort function not active (only for B1KA)
- Ⓝ Service setting active (contractors only)
- Ⓞ Burner in operation

## Check Power Supply Connection

### IMPORTANT

In Canada all electrical wiring is to be done in accordance with the latest edition of CSA C22.1 Part 1 and/or local codes. In the U.S. use the National Electrical Code ANSI/NFPA 70. The heating contractor must also comply with both the Standard for Controls and Safety Devices for Automatically Fired Boilers, ANSI, ASME CSD-1.

A power module is supplied with the Vitodens 100-W boiler, which requires a 120VAC power supply, for simplified installation the boiler is equipped with a 3-prong plug for use with a standard 120VAC wall receptacle.

The voltage at connector X3 must be 120V (see wiring diagram).

## Setup Menu Overview

Item #	Function	Setting Options	Description	Default Setting
1	Filling (see page 40)	0 - Fill mode OFF	After pressing 'OK' the filling function is active. This process will automatically terminate after 30 min.	0
		1 - Fill mode ON		
2	Reduce max. heating output (see page 45)	00 - Low fire (25%)	"The max. heating output can be adjusted according to the requirements of the system. The adjusted heating output should be tested by measuring the gas throughput.	00
		26-99 - Modulation Range (26-99%)		
		100 - High fire (100%)		
3	Altitude setting (see page 45)	0 - < or = 5000 ft (1500 m)	"Adjusts the boiler for high altitude operation.	0
		1-5 - Do Not Adjust		
		6 - > 5000 ft (1500 m)		
4	Do not adjust!	--	--	0
5	Fuel Type (see page 42)	0 - Natural Gas	"The gas type can be converted from natural gas to LPG. Conversion kit is required.	0
		1 - LPG		
6	Do not adjust!	--	--	0
7	Parameter reset	1 - Vitodens 100-W B1KA-35	The parameter is fixed based on the boiler type and size. When replacing the boiler control, refer to boiler rating on the boiler to set model and size. After adjusting the parameter cycle the boiler power and verify the parameter setting.	#
		2 - Vitodens 100-W B1HA-26		
		3 - Vitodens 100-W B1HA-35		
		4-99 - Do Not Adjust		
8	Outdoor Temp. Sensor	0 - NTC 10K Ohm	"The right outside temp. sensor has to be adjusted.	0
		1 - Do not Adjust		
9	Button Tone	0 - On	"The signal tone for display operation can be switched off.	0
		1 - Off		
10	Backlight Display - Standby Mode	0 - Dimmed	"The display backlighting for standby is either dimmed or off.	0
		1 - Off (no back)		
11	Display Contrast	0-6	The display contrast is adjustable from 0 to 6. The higher the value, the greater the contrast.	3
12	Eco/Comfort (B1KA Only) (see page 46)	0 - Eco	"The comfort function makes DHW available faster at the selected set DHW temperature. Only available Vitodens 100-W B1KA	0
		1 - Comfort		
13	Temperature Unit (see page 46)	0 - °C	"The temperature displayed can be set to °C (Celsius) to °F (Fahrenheit).	1
		1 - °F		
14	DHW sensor type (B1HA) (see page 46)	0 - DHW Temp. Sensor (NTC 10K Ohm)	"The boiler either works with a tank sensor (NTC 10kOhm - Supplied) or with a tank aquastat (field supplied)	0
		1 - Aquastat (Dry Contact)		

## Filling and Bleeding the Heating System

**⚠ CAUTION**

Unsuitable fill water increases the level of deposits and corrosion, and may lead to damage to the equipment.

- Thoroughly flush the entire heating system prior to filling with water.
- Only use fill water of potable quality.
- Soften fill water harder than 150 ppm temporary hardness.
- Inhibitors or antifreeze additives suitable for heating systems may be added manually.

### Activating boiler pump (bleeding program)

1. Close the gas shut-off valve.
2. Switch ON the power supply.
3. Tap MODE.

4. ▼/▲ until CONF1 flashes.
5. OK to confirm.  
"P" appears in the left hand display area. The right hand display area flashes.
6. Use ▼/▲ to select "12".
7. OK to confirm.  
"1" flashes in the left hand display area.
8. OK to confirm.  
"0" flashes in the right hand display area.
9. Use ▼/▲ to select "1".
10. OK to confirm.  
Filling is activated. The boiler circuit pump is running, the 3-way diverter valve moves to its centre position. This function terminates automatically after 30 min. or when the ON/OFF switch is switched off.



**Filling and Bleeding the Heating System** *(continued)*

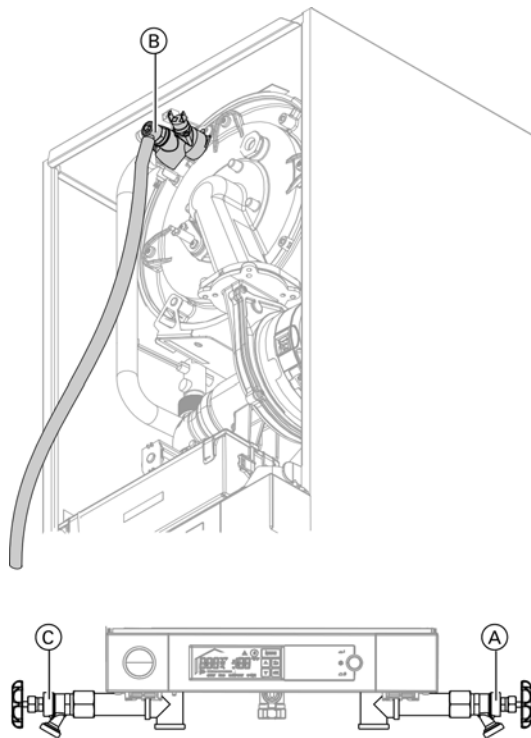

To fill and remove air from the heat exchanger:

- Connect a hose to the boiler filling tap (A) and connect the other end to fresh water supply (or heating medium).
- Connect the hose (supplied with the boiler) to the bleeding port (B) on top of the supply pipe.
- Open the fresh water supply valve and then open the boiler filling tap (A) slowly to fill the boiler with water. Isolation valves (not shown) to isolate system components must be closed during fill/bleed process.
- Using the supplied key, open the bleeding port (B) on the heat exchanger until no sound of escaping air is heard. Open valve (C) to release the remaining air. Close the valves.
- Flush the boiler heat exchanger via the boiler supply and return (for at least 10 min.) until all air has been removed from the boiler.
- When the drain tap (B) begins to bleed water, close the boiler drain valve and open system isolation valves (field supplied).

1. Open system isolation valves (if installed).
  - Note:** Before filling the heating system with water, check that all necessary flow check valves are installed.
2. Check inlet pressure of the diaphragm expansion tank.
  - Note:** If the nitrogen pressure of the precharged expansion tank is less than the static pressure of the system, inflate membrane pressure to slightly exceed pressure of system. The static pressure required at the tank is based upon the static height of the system. The system fill pressure value must be equal to the expansion tank pressure value at approx. 60°F (15.6°C).
3. To remove debris and/or sludge ensure that the system piping is flushed out. Failure to do so may cause sediment in the boiler causing overheating and damage not covered by warranty.
  - Note:** System fill pressure must be approximately 3 psig higher than the static head when the system is cold.
4. Optional:
  - Fill the heating system with water at the boiler filling tap (A) and drain air completely from the drain tap (C).
  - Note:** Water treatment should be considered in areas where it is known that boiler feed water contains a high mineral content and hardness. In areas where freezing might occur, an antifreeze may be added to the system water to protect the system. Please adhere to the specifications given by the antifreeze manufacturer. Do not use automotive silicate-based antifreeze. Please observe that an antifreeze/water mixture may require a backflow preventer within the automatic water feed and influence components such as diaphragm expansion tanks, radiation, etc. A 30% antifreeze content will provide freeze-up protection to -10°F (-23°C). Do not use antifreeze other than specifically made for hot water heating systems. System also may contain components which might be negatively affected by antifreeze. Check total system frequently when filled with antifreeze.
5. Check system pressure.
6. Ensure proper / adequate fuel supply exists.
  - Open gas shutoff valve.
  - Max. boiler operating pressure.....45 psig
  - Min. boiler operating pressure.....12 psig
  - Pressure relief valve.....30 psig

The Vitodens 100-W boiler is for use with gases whose characteristics fall within the following ranges. Do not use any other types of gas.

	Natural gas	Liquid Propane gas
Heating value (gross) Btu/ft <sup>3</sup>	970 to 1100	2466 to 2542
Specific gravity	0.57 to 0.70	1.522 to 1.574
Ultimate carbon dioxide (CO <sub>2</sub> ) %	11.7 to 12.2	13.73 to 13.82

1. Verify that the fuel type listed on the boiler rating plate is the correct type for the installation being attempted.
2. Once verified, record the fuel type in Maintenance Record on page 85.

## Converting Gas Type on the Control Unit

1. Turn on the power.
2. Tap MODE.
3. Tap ▼/▲ until CONFI flashes.
4. Tap OK to acknowledge. There is a "P" in the left hand display. The right hand display flashes.
5. Tap ▼/▲ until "12" is set.
6. Tap OK to acknowledge. "1" flashes in the hand display.
7. Tap ▼/▲ until "5" is set.
8. Tap OK to acknowledge. "0" or "1" flashes in the right hand display.
9. Tap ▼/▲ to set the gas type. "0" for natural gas and "1" for liquid propane.
10. Tap OK to acknowledge.
11. Turn the power OFF then ON. The parameters set are now saved.

## Measure Static Pressure and Running Pressure

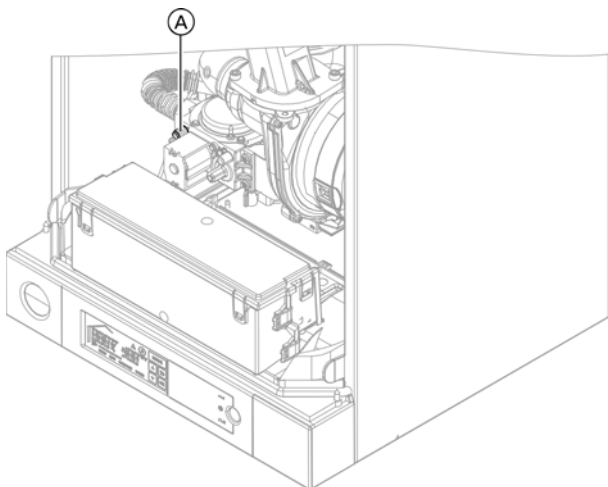

### Legend

Ⓐ Inlet gas pressure measurement port

Measuring running gas supply pressure, using test nipple Ⓐ

### Static pressure

1. To measure static and/or running pressure remove burner cover panel as per the removal instructions on page 38.
2. Close gas shutoff valve.
3. Loosen screw in test nipple Ⓐ on the gas combination valve, do not remove completely. Connect calibrated manometer.
4. Open the gas shutoff valve.
5. Measure static pressure. Values must be:
  - 14 "w.c. max. for NG
  - 14 "w.c. max. for LPG
6. Enter measured value into Maintenance Record on page 85 in this manual.
7. Start up boiler, using the on/off service switch (field supplied).

## IMPORTANT

**A CO<sub>2</sub> measurement (see page 44) must be taken before and after working on gas appliances to eliminate health risks and to guarantee the satisfactory condition of the system.**

**Measure Static Pressure and Running Pressure** *(continued)*

8. All measurements must be made under high-fire conditions.

**Note:** Use suitable measuring instruments calibrated with a minimum resolution of 0.04 "w.c. for measuring the running pressure.

Measure the running pressure; value must be:

Running supply pressure with Natural gas	Running supply pressure with Liquid propane gas	Corrective action
under 4 "w.c.	under 10 "w.c.	Do not attempt adjustment. Call local gas utility to increase pressure.
4 to 14 "w.c.	10 to 14 "w.c.	Start up boiler.
over 14 "w.c.	over 14 "w.c.	Do not attempt adjustment. Call local gas utility to decrease pressure. Boiler valve must not be exposed to pressure over 14 "w.c.

9. Enter gas type into Maintenance Record on page 85 in this manual.
10. Switch off the heating system ON/OFF service switch (boiler is shut down), close the gas shut-off valve, remove the manometer and re-tighten the screw in the test nipple (A).
11. Open gas shutoff valve and check that the test nipple (A) and all gas connections are gas-tight.

 **WARNING**  
 Ensure that there is no open flame in the room.

 **WARNING**  
 Never purge a gas line into a combustion chamber. Never use matches, candles, flame, or other sources of ignition for purpose of checking leakage. Use a soap-and-water solution to check for leakage. A failure to follow this warning could result in fire, explosion, personal injury, or death.

## Checking the CO<sub>2</sub> Content/Relay Tests

The Vitodens 100-W is factory-set for natural gas. During commissioning or maintenance, the CO<sub>2</sub> and CO have to be measured at the boiler flue adaptor test port to check the flue integrity. We recommend measuring O<sub>2</sub>, as the value is unmistakable regarding lambda (air/gas). The O<sub>2</sub> content fluctuates between 7.5 % and 3.2 %. The CO/CO<sub>2</sub> ratio has to be less than 0.004.

If the actual CO<sub>2</sub> or O<sub>2</sub> and CO values deviate from the stated range, check the balanced flue system for leaks. If flue installation is OK, change the gas valve.

**Note:** Operate the appliance with uncontaminated combustion air to prevent operating faults and damage.

**Note:** When the boiler is initially turned on, a self-diagnostic check is initiated. Wait until the temperature display is stabilized and the boiler's actual temperature is displayed.

For high altitude operation above 5,000 ft (1,500 m), refer to page 45 first.

For conversion to propane, see the separate instructions. The CO<sub>2</sub> value lies within the range of;

- 7.5 to 10.5% for natural gas and 10 to 12% for liquid propane gas. The CO<sub>2</sub> value measured must be compared with the above CO<sub>2</sub> value.

	CO <sub>2</sub>	
	high-fire	low-fire
<b>NG range</b>	7.5-10.5%	6.5-10%
<b>Target value</b>	9.1%	8.5%
<b>LPG range</b>	10.0-12.0%	9-11.5%
<b>Target value</b>	10.7%	10.0%

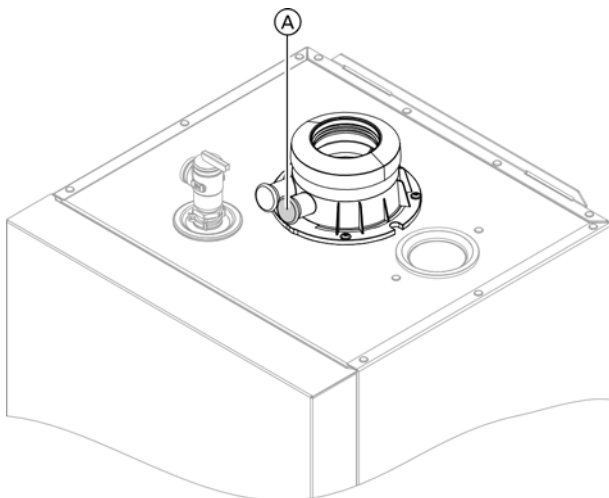

(A) Flue gas measuring port

1. Connect a flue gas analyzer at flue gas port (A) on the boiler flue connection.
2. Start the boiler and check for leaks.
3. To check the CO<sub>2</sub> content the burner output can be adjusted manually.
  1. Tap MODE.
  2. Press ▼/▲ until "SERV" is displayed.
  3. OK to confirm. OFF appears on the display. Test mode is then not activated.
  4. Use ▼/▲ to select the burner output;

Shown on the Display	Burner output
OFF	0%
-	20%
--	40%
---	60%
----	80%
-----	100%

5. Confirm your settings with OK. The bars stop flashing.
4. Check the CO<sub>2</sub> content for the upper heating output (100%).
5. Check the CO<sub>2</sub> content for the lower heating output (20%). The CO<sub>2</sub> content must be between 0.5% and 1.0% below the value of the upper heating output.
6. ■ If the CO<sub>2</sub> content lies within the indicated range, continue with point 8.  
 ■ If the CO<sub>2</sub> content lies outside the indicated range, check the flue gas/ventilation air system for tightness; remedy any leaks. Replace gas valve if required.
7. Re-check the CO<sub>2</sub> content for the higher and lower heating output.
8. Terminate test mode:
  1. ▼/▲ until "SERV" flashes.
  2. OK to confirm. The selected value flashes.
  3. until OFF flashes.
  4. OK to confirm. When "SERV" disappears, test mode is terminated.
9. Shut down the boiler, remove the flue gas analyzer and close flue gas measuring port (A).

## High Altitude Setting

To match the burner output for high altitude setting.

1. Tap MODE.
2. Tap ▼/▲ until CONF1 flashes.
3. Tap OK to confirm.  
"P" is displayed in left hand display area. The right hand display area flashes. Enter 12 with ▼/▲.
4. OK to confirm.  
"1" flashes in left hand display area.
5. Use ▼/▲ to select "3".
6. OK to confirm.  
The right keypad flashes  
Here, the unit of measurement (temperature unit) can be adjusted.  
0 = <= 5,000 ft. (1500 m)  
1 - 5 = not adjust  
6 = > 5,000 ft. (1500 m)
7. Tap ▼/▲ to select altitude.
8. OK to confirm.  
The selected value is adopted.

## Setting Required Heating Input

The maximum heating output can be reduced according to the system requirements.

1. Tap MODE.
2. ▼/▲ until CONF1 flashes.
3. OK to confirm.  
"P" appears in the left hand display area. The right hand display area flashes.
4. Use ▼/▲ to select "12".
5. OK to confirm.  
"1" flashes in the left hand display area.
6. Use ▼/▲ to select "2".
7. OK to confirm.  
The value of the selected maximum heating output, in % of the upper heating output, flashes in the right hand display area.  
Example:  
■ 25 ≙ 25%  
■ 100 ≙ 100%  
See chart.
8. Use ▼/▲ to select the required max. heating output.
9. OK to confirm. The selected value is adopted.
10. Check the selected heating output by measuring the gas throughput.

100%	149 MBH (43.7 kW)	B1KA - DHW boost function
84%	125 MBH (36.6 kW)	B1HA - 35 B1KA - 35 (space heating)
63%	94 MBH (27.5 kW)	B1HA - 26

## Configuring DHW Tank Sensor Input

1. Press the Mode. Tap ▼/▲ until flashes CONF I
2. Confirm with OK. In the left hand display P appears.
3. The right hand display flashes. Select ▼/▲ until 12 appears and confirm with OK.
4. 1 appears in the left hand display and flashing. Select using ▼/▲ 14 and confirm with OK.
5. The right hand display flashes  
Here, the input X20: to configure 9/10 (refer to page 3 for connection).  
0 = Sensor (NTC 10k)  
1 = Aquastat  
Change ▼/▲. (The factory setting is 0)  
Confirm tap OK. Settings have been applied.

**Note:** The DHW tank sensor is supplied with installation fittings.

## Setting the Unit of Measurement (temperature unit)

1. Press the Mode. Tap ▼/▲ until flashes CONF I
2. Confirm with OK. In the left hand display area P appears.
3. The right hand display area flashes. Select ▼/▲ until 12 appears and confirm with OK.
4. 1 appears in the left hand display area and flashes. Select 13 using ▼/▲ and confirm with OK.
5. The right hand display area flashes. Here, the unit of measurement (temperature unit) can be adjusted.  
0 = °C  
1 = °F  
Taping ▼/▲ change the temperature unit.  
(The factory setting in °F)  
Finally, tap OK. Settings have been applied.

## Setting the DHW Comfort Function

Only possible for B1KA boiler. The comfort function makes DHW available faster at the selected set DHW temperature by keeping the DHW heat exchanger preheated.

1. Turn ON the ON/OFF switch.
2. Tap MODE.
3. ▼/▲ until CONF I flashes.
4. OK to confirm.  
"P" appears in the left hand display area. The right hand display area flashes.
5. Use ▼/▲ to select "12".
6. OK to confirm.  
"1" flashes in the left hand display area.
7. Use ▼/▲ to select "12".
8. OK to confirm.  
"0" flashes in the right hand display area.
9. Use ▼/▲ to select the comfort function.  
■ "0": Without comfort function  
or  
■ "1": With comfort function
10. OK to confirm.

## Clock Natural Gas Meter

### IMPORTANT

A boiler under fired by 5% is still acceptable.  
Do not over fire the boiler.



### CAUTION

Always contact your gas utility to obtain the correct heating value before clocking the meter.

Clock natural gas meter to verify input

1. Ensure all other gas equipment served by the meter is turned off during timing of gas input to the Vitodens 100-W boiler.
2. Measure the time in seconds it takes for the boiler to use 10 cu. ft. of gas. Divide 3600 x 10 by the number of seconds and you get the number of cu. ft. of gas used per hour. Multiply this number by the heating value of the gas to obtain Btu per hour input.

For example:

A Vitodens 100-W boiler (118 000 Btu/h input) requires 305 seconds to use 10 cu. ft. of natural gas. After contacting the local utility, you find the heating value is e.g.

1000 Btu per cu. ft.

Therefore,

$$((3600 \times 10)/305) \times 1000 \cong 118\,000 \text{ Btu/h input.}$$

Therefore, the boiler input is correct.

Burner input formulas (up to 4500 ft.):

$$\text{INPUT} = (3600 \div t) \times 1000 \text{ where}$$

$$t = \text{TIME (sec.) for } 1 \text{ ft.}^3$$

$$\text{INPUT} = (3600 \times .01 \times 1000 \times 35.31) \div T \text{ where}$$

$$T = \text{TIME (sec.) for } .01 \text{ m}^3 \text{ natural gas}$$

## Check all Primary and Secondary Circuit Connections for Leaks

Check heating system and domestic hot water connections (if applicable). Ensure all connections are pressure tight.

Correct any leaks found on fittings, pumps, valves, etc.

## Perform Combustion Analysis

### IMPORTANT

A CO<sub>2</sub> measurement (see page 44) must be taken before and after working on gas appliances to eliminate health risks and to guarantee the satisfactory condition of the system.

Record the measured combustion values in the sequence stated in the Maintenance Record on page 85 in this manual.

## Check Venting System for Leaks (circular air gap measurement)

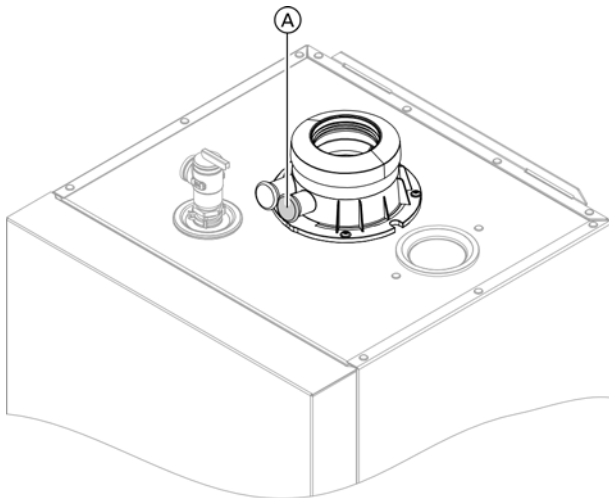

### Legend

Ⓐ Flue gas measurement port

### For sealed combustion, coaxial vent only

Viessmann strongly recommends that the heating contractor perform a simplified leak test during boiler start-up. For this purpose it is sufficient to measure the CO<sub>2</sub> concentration of the combustion air in the coaxial gap of the air intake pipe. The vent pipe is considered sufficiently leak-proof if a CO<sub>2</sub> concentration in the combustion air no higher than 0.2% or an O<sub>2</sub> concentration no lower than 20.6% is measured.

If higher CO<sub>2</sub> values or lower O<sub>2</sub> values are measured, check venting system thoroughly.

**Note:** The vent pipe adaptor comes with two measurement ports, one for combustion air intake measurement and one for flue gas measurement.

**Note:** This test is not applicable for single-wall venting systems (non-sealed combustion).

## Removing the Front Panel

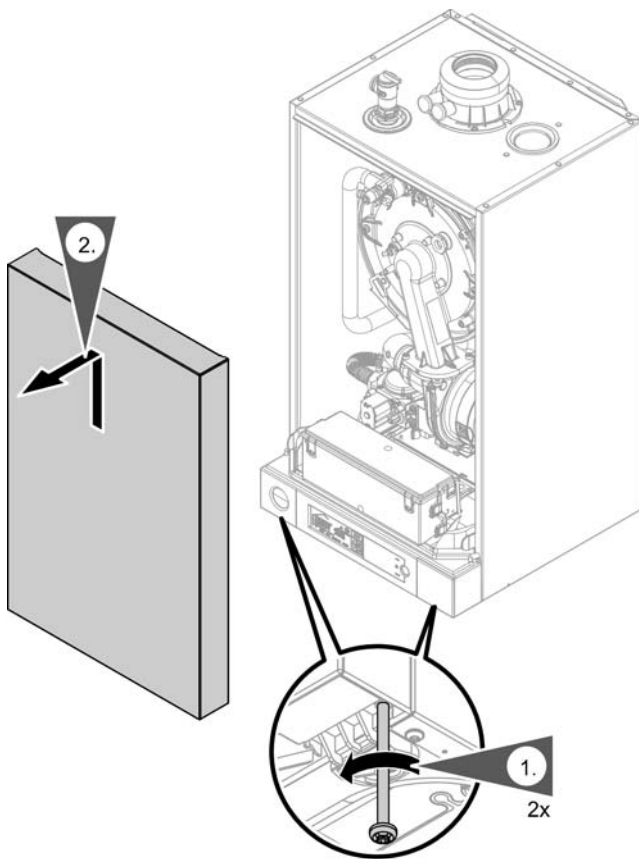

To ensure continued efficient operation of the boiler, it is recommended that it is checked and serviced as necessary at regular intervals. The frequency of servicing will depend on the particular installation conditions and usage but in general once a year should be adequate. Any service work must be carried out by a licensed professional heating contractor.

The boiler incorporates a flue gas measurement port. The flue gases can be analyzed (if required). The push fit cap may be removed and a sample tube installed. The push fit cap must be refitted after use. The flue gas sample will enable the heating contractor to judge whether any adjustments are required. Before commencing any service operation, isolate and secure the main power supply against accidental reactivation, and turn off the main gas supply.

1. Loosen retaining screws, screws are captive and do not need to be fully removed.
2. Remove the front panel.



## Removing the Burner

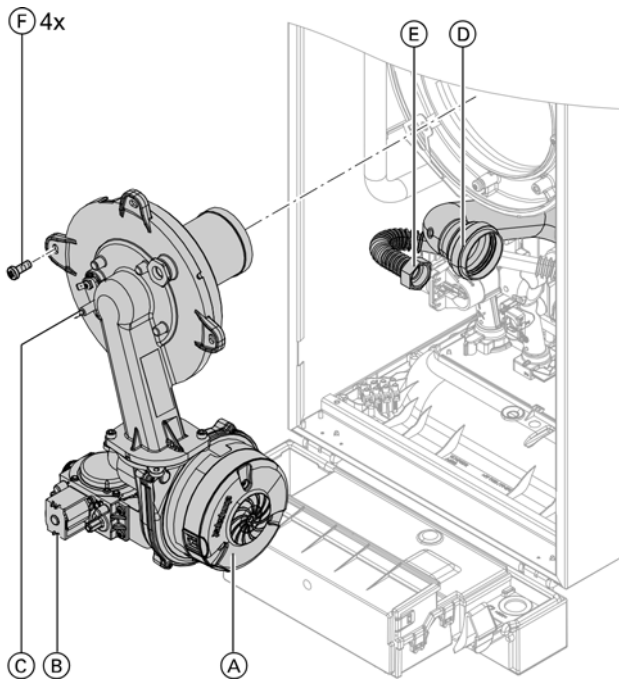

1. Switch the burner OFF (shut off main service switch).
2. Shut off the gas supply.
3. Pull power cables from fan motor (A), gas valve (B) and electrode block (C).
4. Pull the Venturi extension (D) from the fan.

### CAUTION

To avoid damage to the burner, do not lay burner on its cylindrical burner tube. Failure to heed this caution may cause damage to the burner tube, which may lead to improper operation.

5. Release gas supply pipe fitting (E).  
**Note:** There is a gasket between the gas valve and this connection.
6. Loosen four Torx (T-30) screws (F) and remove burner.

## Check Burner Gasket and Cylinder Assembly for Damage

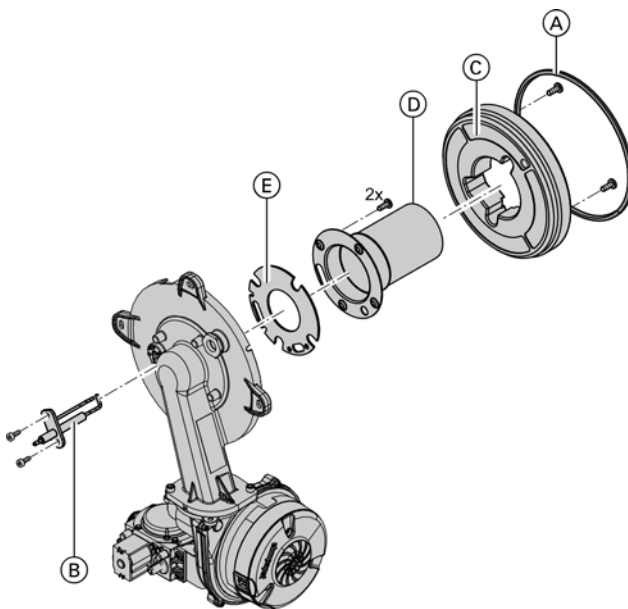

Check the burner gasket (A) and burner cylinder assembly (D) for damage and replace if necessary. Replace the cylinder burner assembly if damaged.

1. Remove electrode block (B).
2. Loosen the three Torx screws and remove the thermal insulation ring (C).
3. Loosen the four Torx screws and remove burner cylinder assembly (D) and assembly gasket (E).
4. Fit and secure new burner cylinder assembly (D) and new assembly gasket (E). Tighten to a torque of 31 lb.in (3.5 Nm) using a calibrated torque wrench.
5. Reinstall thermal insulation ring (C).
6. Reinstall electrode block (B). Tighten to a torque of 31 lb.in (3.5 Nm) using a calibrated torque wrench.

## Check and Adjust Ignition and Ionization Electrodes

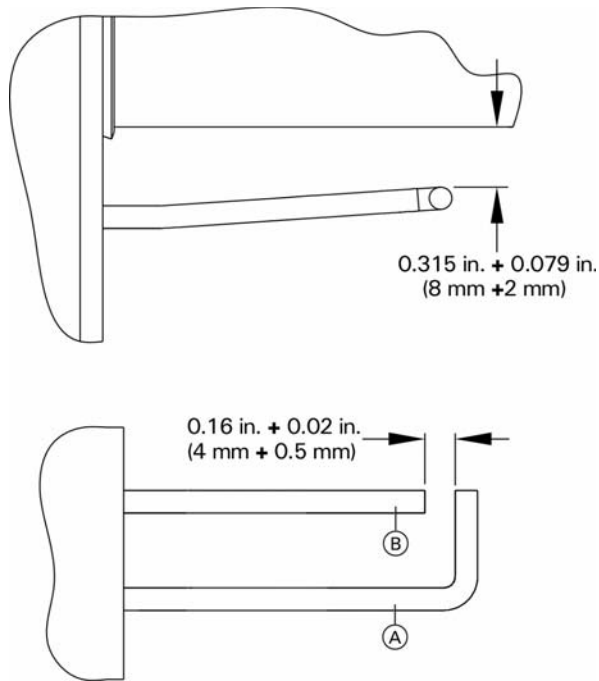

1. Check ignition and ionization electrode block for wear, contamination, warping or cracked insulation.
2. Clean electrodes with a small brush or emery paper.
3. Check clearances. If clearances are not within specification or the electrodes are damaged, replace electrode block and gasket and align. Tighten fastening screws for the electrodes to a torque of 40 lb.in (4.5 Nm) using a calibrated torque wrench.
4. Reinstall grounding wire.

### Legend

- Ⓐ Ignition ionization electrode
- Ⓑ Ground

## Check Condensate Drain and Clean Siphon (P-trap)

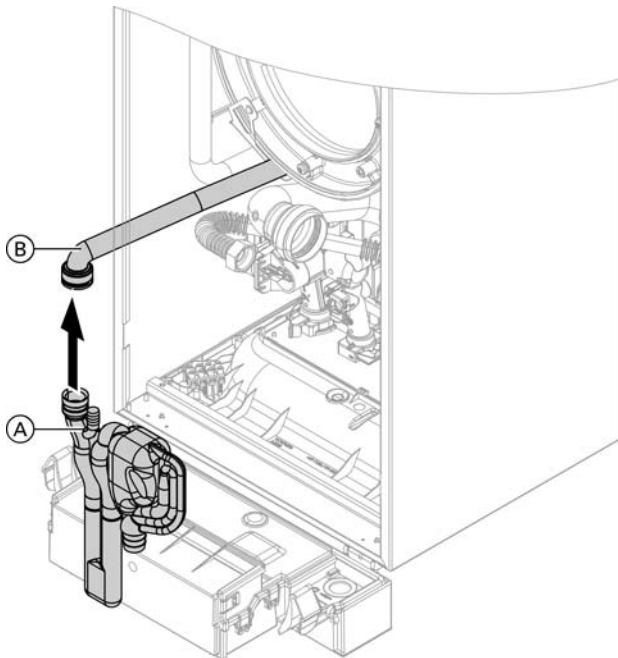

1. Check the siphon to ensure unimpeded drainage of condensate.
2. Remove all hoses from siphon Ⓐ.
3. Release locking tabs at opening Ⓑ from underneath and remove siphon Ⓐ upwards.
4. Clean siphon Ⓐ and reinstall.
5. Refit all hoses. Secure drain hose with cable ties.
6. Fill the siphon Ⓐ with water by pouring 10 fl. oz. (0.3L) of water into the combustion chamber.

### IMPORTANT

If the condensate does not drain freely, condensate will accumulate in bottom part of boiler resulting in a burner shut-down (fault message F4). The combustion chamber refractory will also become wet at the bottom. Do not restart the boiler immediately with a wet combustion chamber refractory. This will damage the refractory. Either dry the refractory (i.e. using a hair dryer) or replace it.



Installation Instructions Neutralization Unit (if applicable)

## Check Neutralization Unit (if applicable)

1. Check the pH value of the condensate with a pH measuring strip. If the pH value is less than 6.5, replace granulate.
2. If contaminated: Rinse neutralization unit with tap water.
3. Add granulate as marked on the cartridge.

### IMPORTANT

pH measuring strip is field supplied.

### IMPORTANT

The granulate is consumed as it neutralizes the condensate. The red marking indicates the min. filling level.



Installation Instructions Neutralization Unit

## Clean Combustion Chamber/Heat Exchanger Surfaces

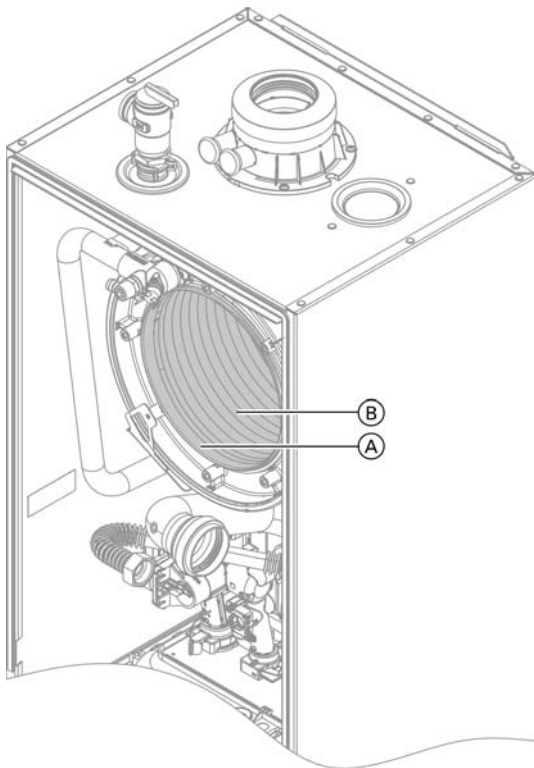

1. Remove burner cover panel as per the removal instructions on page 38 in this manual, and reinstall panel upon completion of service work.
2. If necessary, clean the combustion chamber (A) and heat exchanger surfaces (B) by vacuuming loose debris, then spray brush and rinse with water. Use solvent-free cleaning agents to remove residues:
  - Remove combustion by-product deposits with alkaline agents containing tenside.
  - Remove coatings and (yellowish brown) surface discoloration with phosphoric acid-based "Antox 75 E Plus", or citric acid-based CitriSurf 3050 or CitriSurf 77 by Stellar Solutions Inc.
  - Rinse thoroughly with water.

**Note:** Be careful not to scratch parts which are in contact with flue gas. Use plastic brushes, not wire brushes! The cleaning agents must not contain hydrocarbon-based solvents or potassium.
3. Connect electrical cables to corresponding parts.

### WARNING

Follow cleaning agent manufacturer's safety instructions and wear appropriate protective equipment.

### IMPORTANT

Perform leak test.

## Check Diaphragm Expansion Tank and System Pressure

Perform check on the system when cold.

1. Drain boiler/system and reduce pressure until the manometer reading is "0".
2. If the nitrogen pressure of the pre-charged expansion tank is less than the static pressure of the system, inflate membrane pressure to slightly exceed pressure of system.

The static pressure required at the tank is based upon the static height of the system. The system fill pressure value must be equal to the expansion tank pressure value at approx. 60°F (15.6°C).

**Note:** Static head of 33 ft. (10 m) (distance between boiler and topmost heat emitter surface) corresponds to a static pressure of 1 bar (15 psig).

3. Top up with water until filling pressure is higher than the inlet pressure of the diaphragm expansion tank.

**Note:** With the system cold, the filling pressure must be approx. 3 psig higher than the static pressure.

Max. boiler operating pressure.....	45 psig
Min. boiler operating pressure.....	12 psig
Pressure relief valve.....	30 psig

4. When starting up the system for the first time, mark this value as the minimum filling pressure on the manometer.

**Note:** A lower manometer reading usually indicates loss of water due to leakage. All leaks must be repaired.

## Check Functioning of Safety Valves

Ensure proper operation of low water cut-off(s) (if applicable), pressure relief valve, and pump(s).

Check pressure gage, air vent and pressure relief valve. Ensure that pressure relief valve does not leak and that it operates in accordance with information provided by the original manufacturer.

Flush float water type low water cut-offs (if used).

Follow local regulations with respect to backflow preventers.

If oil-lubricated pumps are used, ensure proper lubrication.

If motorized zone valves are used, refer to maintenance instructions provided with zone valves.



Refer to maintenance instructions supplied with low water cut-offs, pumps, etc.

## Check Gas Pipes and Fittings for Leaks



### WARNING

The gas supply piping must be leak tested before placing the boiler in operation.



### CAUTION

Ensure all joints of gas line are pressure tight and that gas valves do not leak when under normal operating pressure (use approved leak detection liquid). Do not use open flame.

## Reinstall Burner

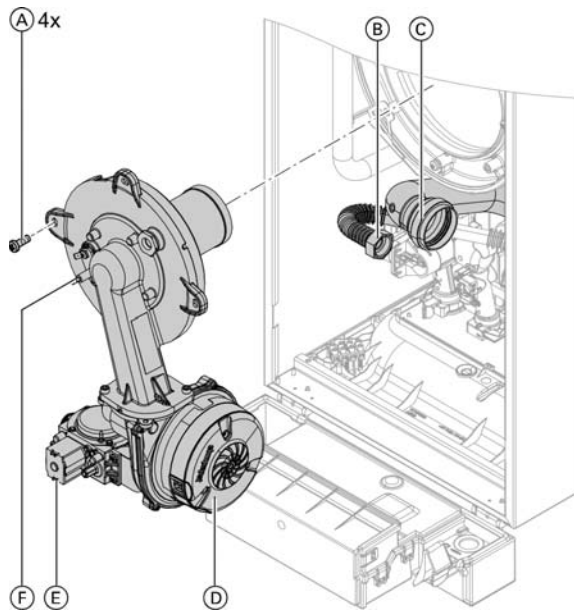

1. Fit burner and tighten 4 T-30 screws (A) diagonally to a torque of 35 lb.in (4 Nm).
2. Insert new supplied gasket and tighten the fitting (B) on the gas connection pipe to a torque of 132 lb.in (15 Nm).
3. Plug the Venturi extension (C) into the radial fan (D).
4. Replace electrical cables from gas valve (E), and electrode block (F).
5. Open gas shutoff valve and switch on power supply.
6. Check the gas connection for tightness.
7. Reinstall front panel, as shown below.

## Reinstall Front Panel

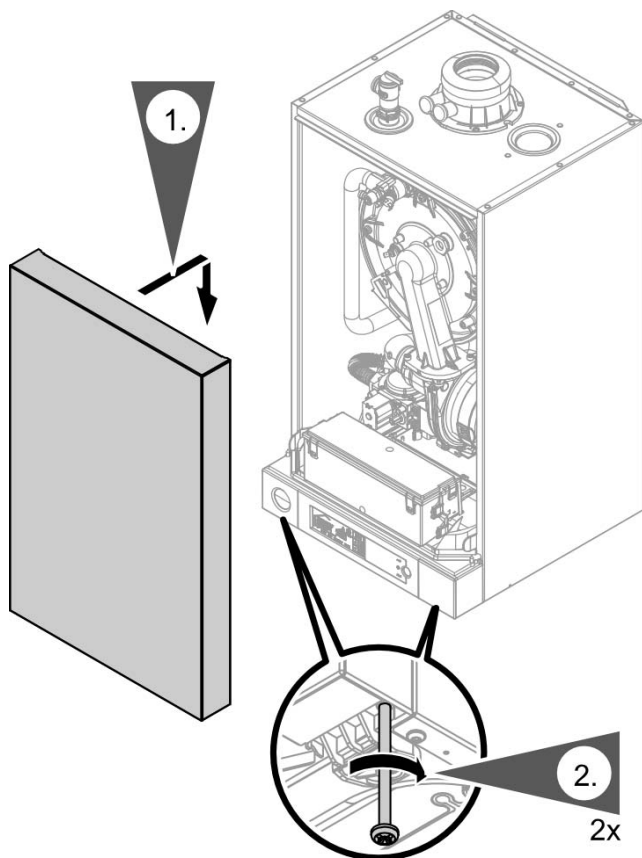

1. Install the front panel.
2. Tighten the screws at the bottom of the boiler.

## Troubleshooting Steps

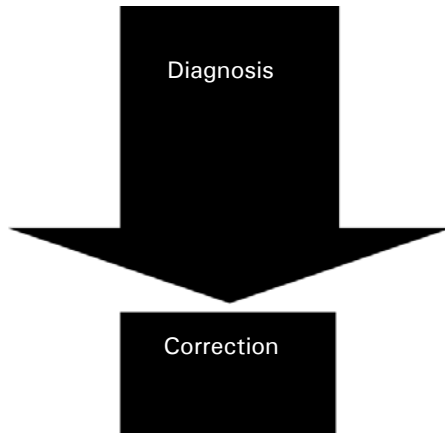

1. Establish fault message or diagnose behavior of system.
2. Look for corresponding cause of fault in the diagnostics table.
3. Find corrective measures in the table.
4. Perform corrective measures (page 58 to 63).

**Note:** See page 39 for an overview of controls, indicators and system components.

## Changing Room Temperature

In case a separate external room temperature controller (thermostat) is installed, the desired room temperature will be adjusted using this device.

Make adjustments using the appropriate operating instructions only.

**Note:** If thermostatic radiator valves are installed in the room where the control is installed they must be fully open.

In case the room temperature setting on the separate room temperature controller is not sufficient to achieve the desired room temperature (e.g. during a particularly cold winter), the boiler water temperature can be adjusted accordingly.

# Diagnosis

Sequence of operation and potential faults during each start-up cycle

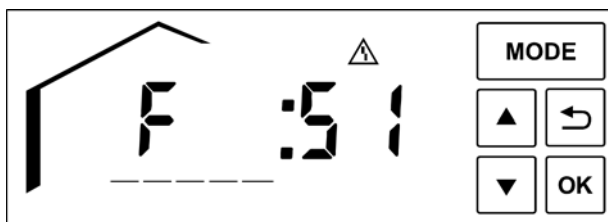
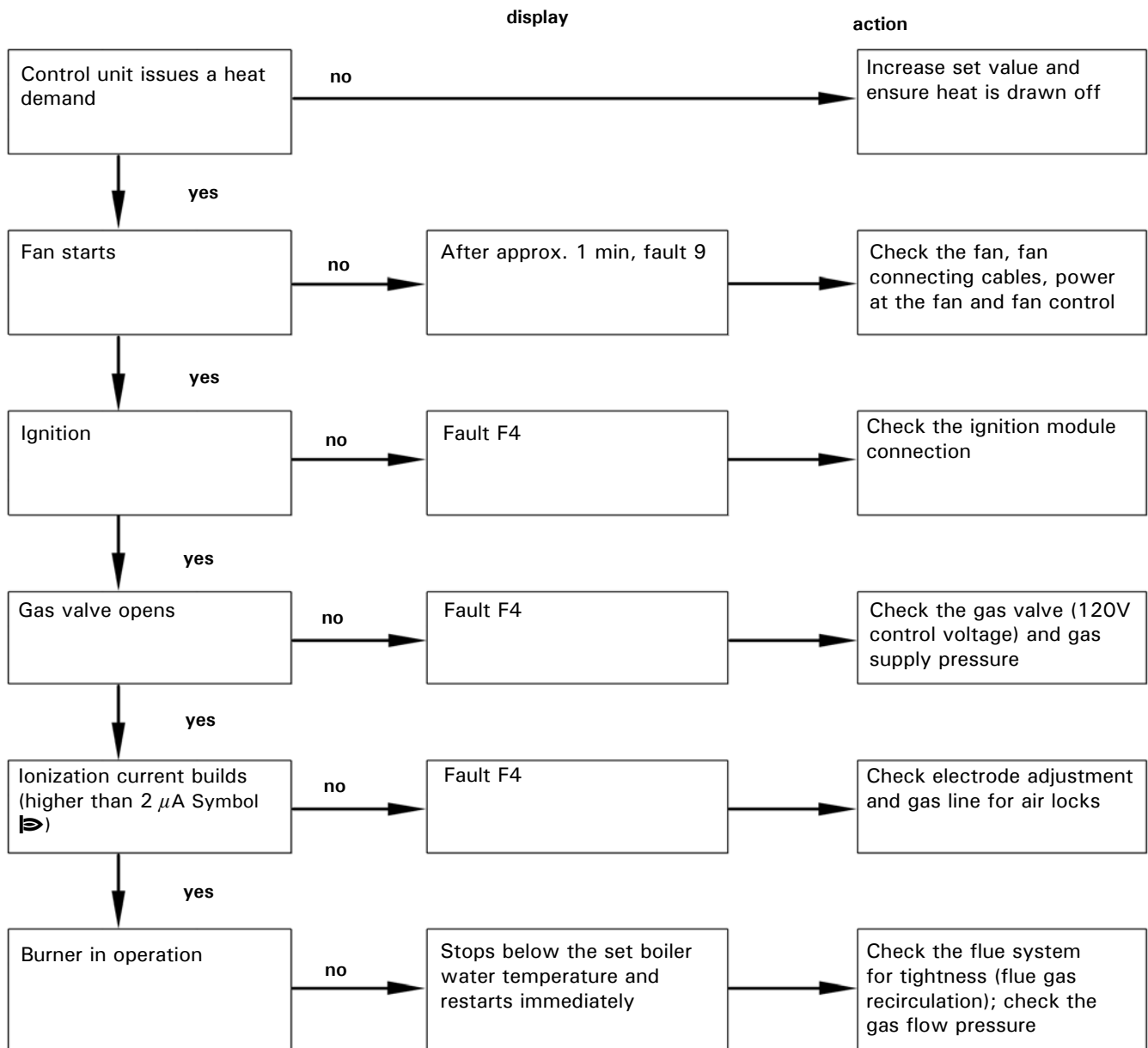

### Fault display

In case of a fault, the display will show  and the fault code.

If  flashes and "R" appears, the burner is locked.

See page 39.

For an explanation of the fault codes, see the following table.

**Diagnosis** *(continued)*

**Diagnostics table: Faults with fault display on control unit**

Fault code in display window	System characteristics *1	Cause	Corrective measures
E9	Burner blocked	CO limiter (if installed) has responded. CO concentration too high.	Check the heating system. Remove the cause of escaping CO.
		Gas pressure switch (if installed) has responded. Gas pressure too low.	Check the gas supply.
E6	Burner blocked	Low water, pump, flow switch defective	Check water pressure, circulation pump, flow switch
E7	Burner blocked	Mains voltage too low	Check the power supply.
E8	Constant mode	Outdoor temperature sensor shorted out	Check the optional outdoor temperature sensor and wiring (see page 59).
E8	Constant mode	Outdoor temperature sensor wire broken	Check the outdoor temperature sensor and wiring (see page 59).
F0	Burner blocked	Boiler water temperature sensor shorted out	Check the boiler water temperature sensor (see page 58).
F0	Burner blocked	Boiler water temperature sensor wire broken	Check the boiler water temperature sensor (see page 58).
F1	No DHW heating	Tank temperature sensor shorted out	Check sensor (see page 62)
F1	No DHW heating	Outlet temperature sensor shorted out	Check sensor (see page 62).
F2	Burner blocked	Flow sensor shorted out	Check connections and wire; replace sensor if required.
F3	No DHW heating	Tank temperature sensor wire broken	Check sensor. (see page 62)
F3	No DHW heating	Outlet temperature sensor wire broken	Check the sensor (see page 62).
F4	Burner blocked	Flow sensor wire broken	Check connections and wire; replace sensor if required.
F5	Burner blocked	Flue gas temperature sensor incorrectly positioned.	Position flue gas temperature sensor correctly.
F5	Regulated operation without OpenTherm device	Communication fault OpenTherm device	Check connections and wire; replace OpenTherm device if required.
F6	Burner blocked	Flue gas temperature sensor shorted out	Check sensor (see page 61).
F7	Emergency mode	Burner control unit fault	Reset boiler control
F8	Burner blocked	Flue gas temperature sensor wire broken	Check sensor (see page 61)



**Diagnosis** *(continued)***Diagnostics table: Faults with fault display on control unit** *(continued)*

Fault code in display window	System characteristics *1	Cause	Corrective measures
E3	Burner in fault mode	Fault in safety chain	Check the fixed high limit and connecting cables (see page 61). Check the control unit, and replace if required.
E5	Burner blocked	Internal fault	Check the ionization electrode and connecting cable. Press reset (see page 50).
E6	Burner blocked	Internal fault	Replace the control unit.
F1	Burner in fault mode	Maximum flue gas temperature exceeded	Check the heating system fill level, circulation pump and bleed system. Reset control.
F2	Burner in fault mode	Fixed high limit tripped	Check the heating system water level. Check the circulation pump. Bleed the system. Check the fixed high limit and connecting cables. Reset control.
F3	Burner in fault mode	Flame signal is already present at burner start	Check the ionization electrode and connecting cable. Reset control.
F4	Burner in fault mode	No flame signal is present	Check ignition electrodes and wires. Measure the ionization current, check the gas pressure, check the gas valve, ignition, ignition module and condensate drain. Reset control. Check ignition cable resistance (4.5K to 5K ohms).
F8	Burner in fault mode	The combination gas valve closes too late	Check the gas valve. Check both control paths. Reset control.
F9	Burner in fault mode	Blower speed too low at burner start	Check the blower, check the blower cables and supply; check the blower control. Reset control.
Fa	Burner in fault mode	Blower not at stand-still	Check the blower, blower connecting cables and blower control. Reset control.
Fc	Burner blocked	Electrical fan control (control unit) faulty	Check fan connecting cable; if required replace cable or replace control unit. Reset control.
Fd	Burner blocked	Burner control unit fault	Check ignition electrodes and connecting cables. Check whether a strong interference (EMC) field exists near the equipment (correct if applicable). Reset control. Replace control unit if the fault persists.
Ff	Burner blocked	Burner control unit fault	Check ignition electrodes and connecting cables. Check whether a strong interference (EMC) field exists near the equipment (correct if applicable). Reset control. Replace control unit if the fault persists.

**Reset activation** (reset burner control unit)

Touch R for approx. 2 sec.

If the fault has been removed, the fault symbol "  " disappears and the default display is shown or a further fault message is displayed.

If the fault persists, the fault message appears again.

## Boiler Connection

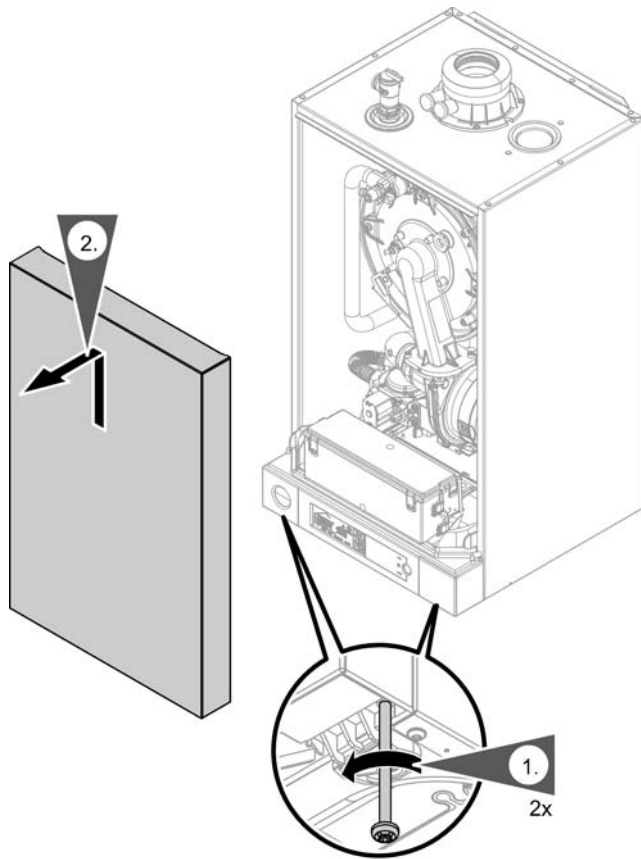

### Remove front panel

1. Loosen retaining screws, screws are captive and do not need to be fully removed.
2. Remove the front panel.

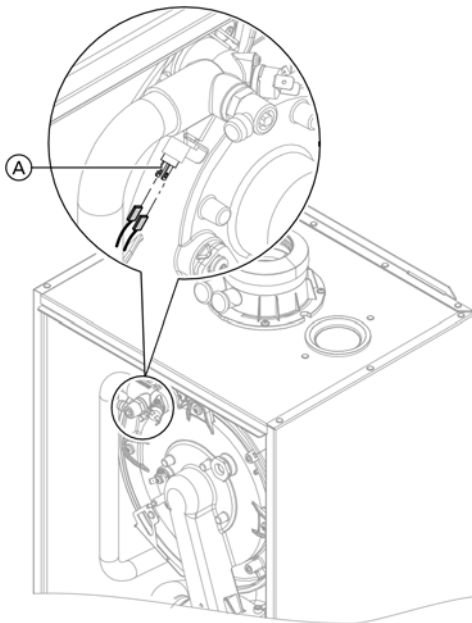

### Check boiler temperature sensor

1. Disconnect cables from boiler temperature sensor (A).
2. Measure resistance of the boiler temperature sensor and compare with resistance/boiler water temperature curve shown.
3. If the value measured differs significantly, replace the sensor.

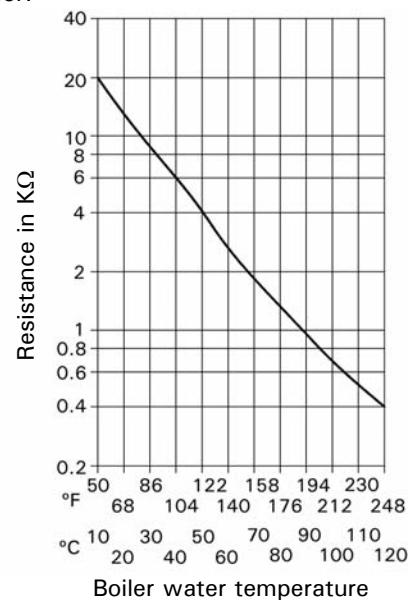

### WARNING

The boiler temperature sensor is immersed in the heating water (risk of scalding). Drain the boiler before replacing the sensor.

**Boiler Connection** *(continued)*

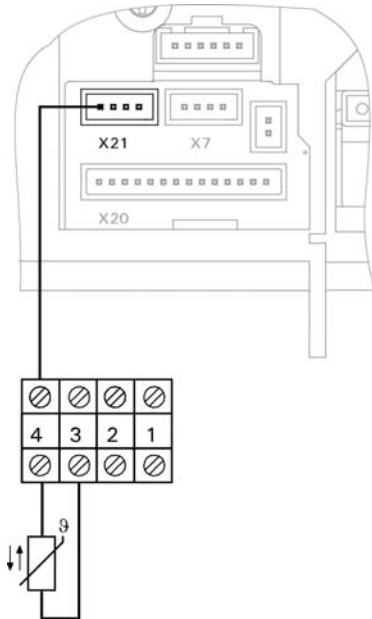

**Check outdoor temperature sensor**

1. Disconnect cables from outdoor sensor.
2. Measure resistance of the outdoor sensor and compare with resistance / outdoor sensor curve shown below.
3. If the value measured differs significantly, replace the sensor.

In weather-compensated mode (optional), the boiler water temperature is regulated subject to the outdoor temperature.

**Frost protection function**

Built-in automatic frost protection allows the boiler to be shut off for an extended period of time while protecting it against freeze-up. Frost protection is continually active. The burner is switched ON when the boiler water temperature reaches 41°F (5°C) and is switched OFF again when the boiler water temperature reaches at least 59°F (15°C) [but not more than 68°F (20°C)].



For details on the control, please refer to the Vitodens 100-W Operating Instructions.

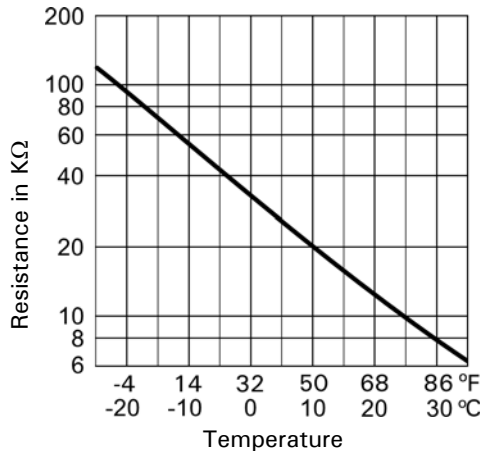

**Boiler Connection** *(continued)*

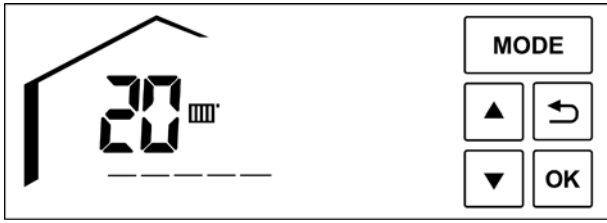

**Heating curve for weather-compensated control**

In weather-compensated mode, the boiler water temperature is regulated subject to the outside temperature. Parameter default setting is 20 (or 68 if display is converted to °F).

**Set heating curve**

1. Tap ▼/▲.  
The set parameter flashes and  will be displayed.
2. Use ▼/▲ to select the parameter.
3. OK to confirm.  
**Note:** When adjusting this setting, bear in mind that your heating system requires some time to heat the home to the required temperature.

**Frost protection function**

The frost protection function requires an outside temperature sensor to be connected. The frost protection function becomes active at outside temperatures of <41°F (<5°C). The burner starts and the boiler water temperature is held at 68°F (20°C).

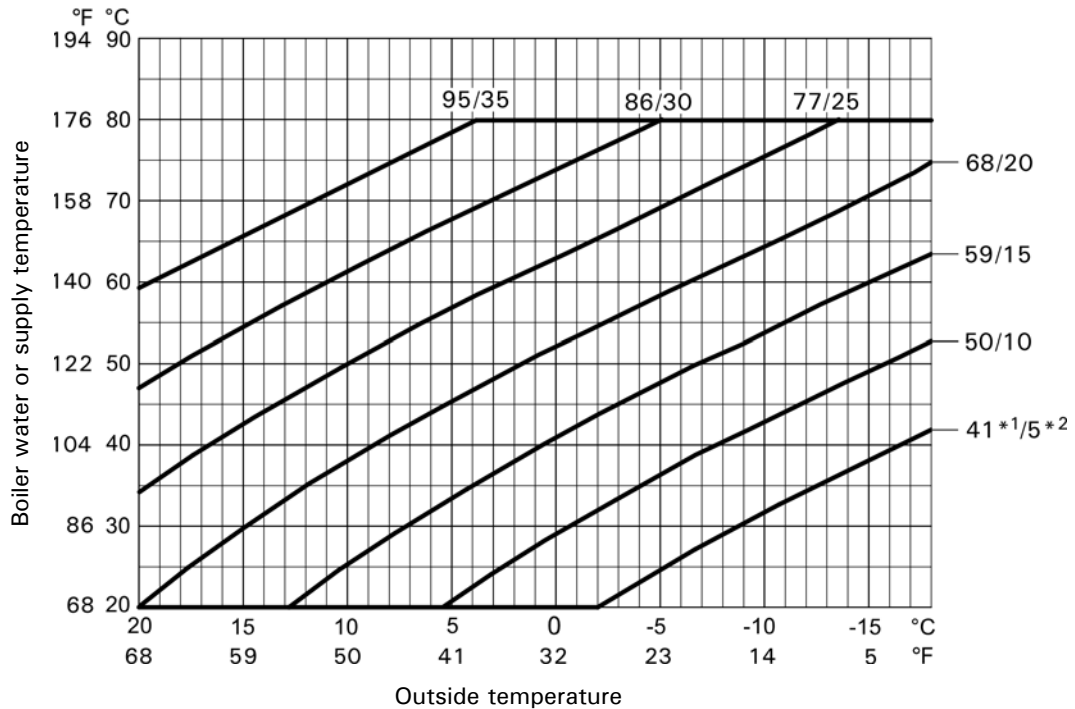

The setting range is dependant on the temperature control display (°C/°F).

When the control is set to °F the display will read 'off'. Tap up with ▼/▲ and the display will read 41\*1. Tap ▼/▲ for increments of 1.

When the control is set to °C the display will read 'off'. Tap up with ▼/▲ and the display will read 5\*2. Tap ▼/▲ for increments of 1.

**Boiler Connection** *(continued)*

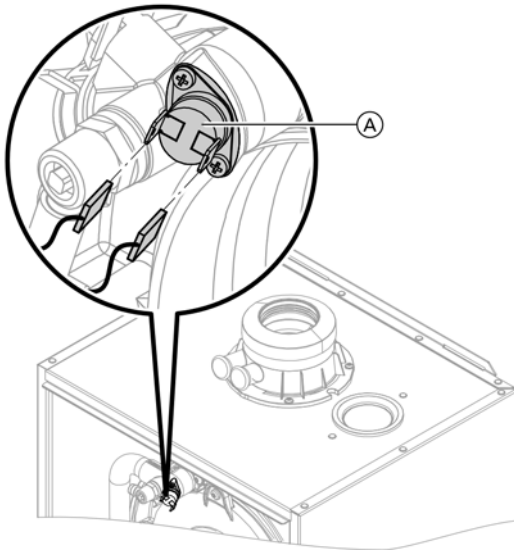

**Check fixed high limit**

If the burner control unit cannot be reset after a fault shutdown (F<sub>2</sub>), even though the boiler water temperature is below approx. 203°F (95°C), check the fixed high limit.

1. Pull the leads from fixed high limit (A).
2. Check the continuity of the fixed high limit with a multimeter.
3. Remove faulty fixed high limit.
4. Coat the replacement fixed high limit with heat conducting paste and install.
5. To reset, refer to page 76.

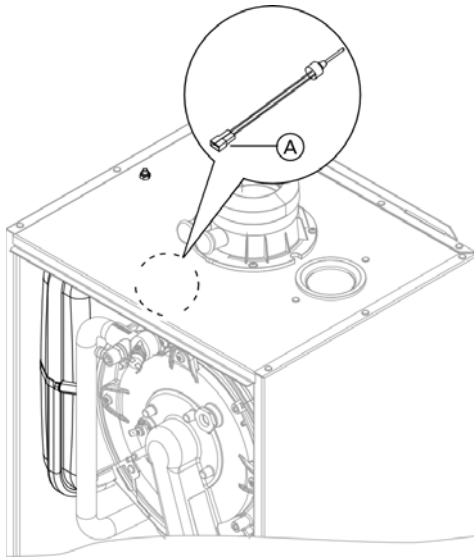

**Check flue gas temperature sensor**

1. Pull the leads from flue gas temperature sensor (A).
2. Check the sensor resistance and compare it with the curve.
3. Replace the sensor in case of severe deviation.

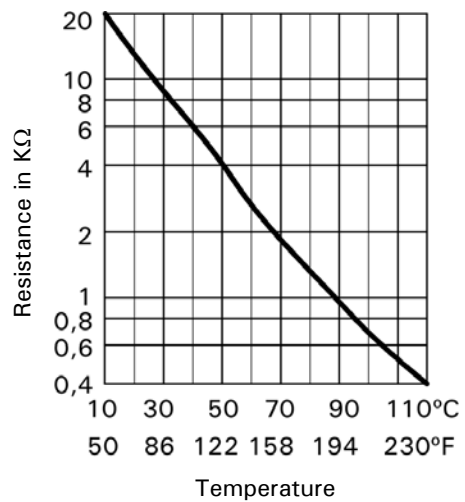

**Boiler Connection** *(continued)*

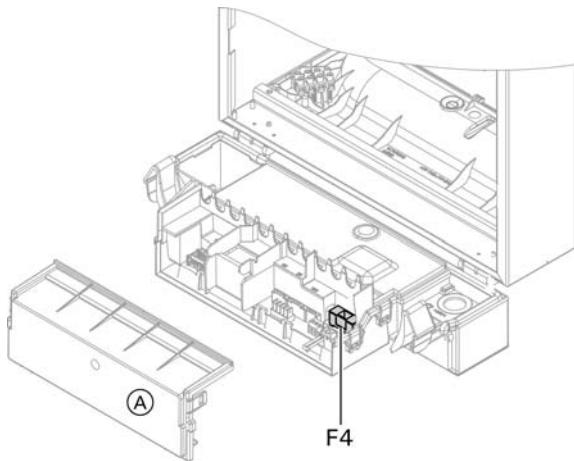

**Check Control unit fuse**

1. Switch off main power supply.
2. Flip down control unit.
3. Remove cover (A).
4. Check fuse F4 T 2.5A (slow blow).  
Replacements fuses are available from Viessmann.

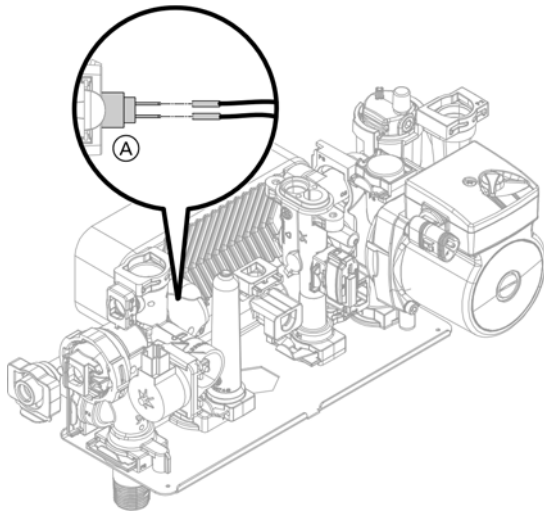

**Check DHW outlet temperature sensor (B1KA only)**

1. Pull the leads from outlet temperature sensor (A).
2. Check the sensor resistance and compare it with the curve.
3. Replace the sensor in case of severe deviation.

**Note:** Water can leak when replacing the outlet temperature sensor. Shut off the cold water supply. Drain the DHW line and the plate type heat exchanger (DHW side).

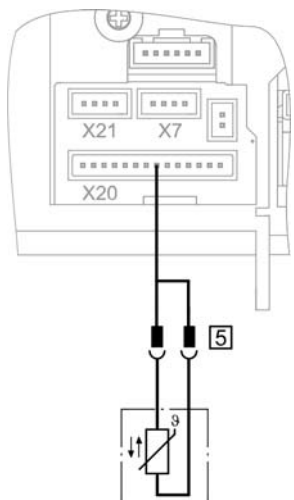
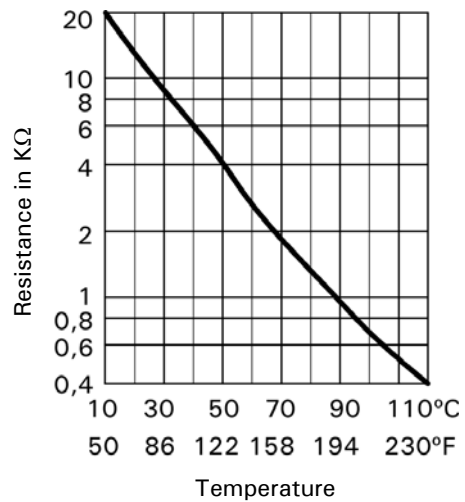

**Check DHW tank temperature sensor (B1HA only)**

1. Remove plugs (5) from the cable harness.
2. Check the sensor resistance and compare it with the curve.
3. Replace the sensor in case of severe deviation.

**Boiler Connection** *(continued)*

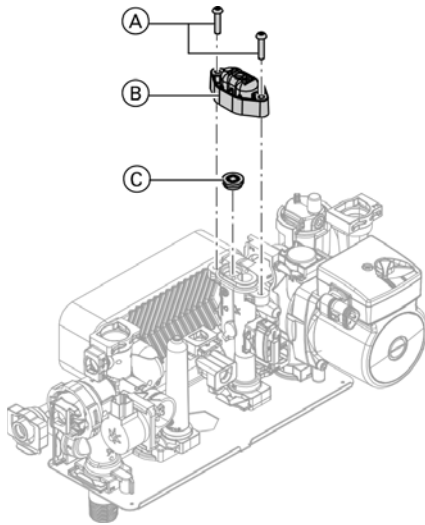

**Replacing the flow limiter (B1KA only)**

1. Drain or isolate the DHW system and shut off DCW.
2. Undo screws (A).
3. Remove the cap (B).
4. Remove faulty flow limiter (C).
5. Insert new flow regulator (C).
6. Fit new cap (B) provided.

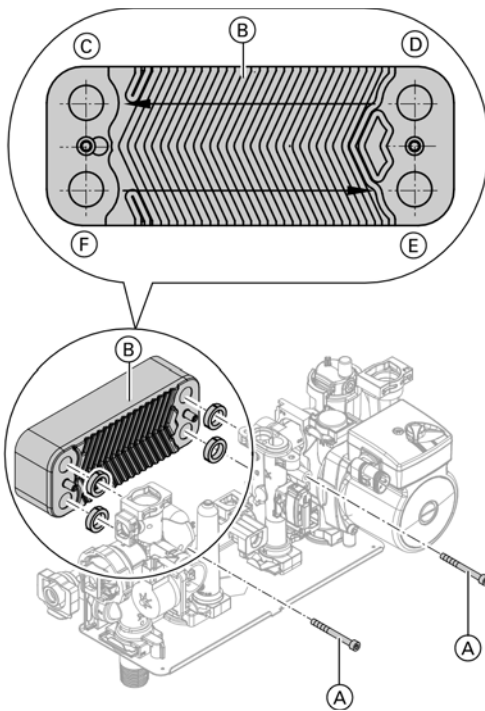

**Checking or replacing the plate type heat exchanger (B1KA only)**

1. Shut off or isolate and drain the boiler on the heating water and the DHW side.
2. Pivot control unit downwards.
3. Remove two screws (A) from the plate-type heat exchanger and remove the plate-type heat exchanger (B) with gaskets.
 

**Note:** During removal, small amounts of water may trickle out and escape from the removed plate-type heat exchanger.
4. Check the DHW side for scaling and if required, clean or replace the plate-type heat exchanger.
5. Check the heating water side for contamination and if required, clean or replace the plate-type heat exchanger.
6. Install in reverse order with new gaskets.

**Note:** Refer to the installation Instructions for additional mounting options.

**Legend**

- (A) Screws
- (B) Plate-type heat exchanger
- (C) Heating water return
- (D) Heating water supply
- (E) DCW
- (F) DHW

## Electrical Connections to the Terminal Strip for Accessories

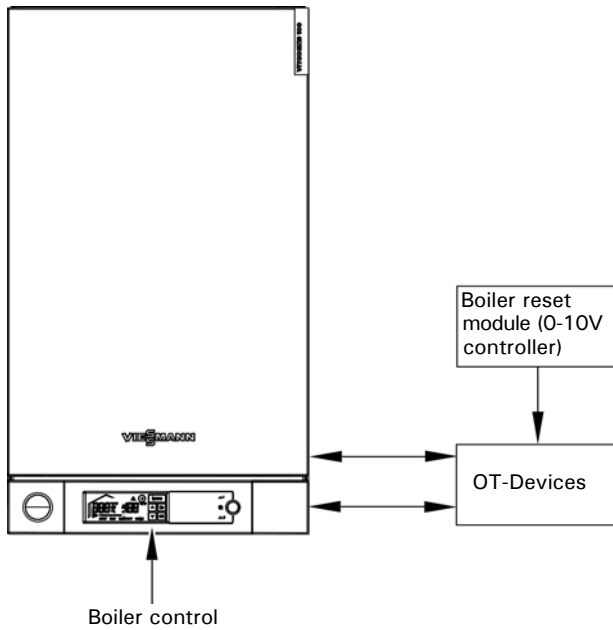

Follow the installation instructions of field supplied operating controls.

### What is OpenTherm (OT)?

The OpenTherm (OT) protocol is a point-to-point communication system, which connects a boiler with a room controller or other devices. The room unit calculates a heating demand (water temperature request) and transmits it to the boiler. The boiler will adjust the heat input accordingly (low-high modulation).

The Viessmann Input Module is designed to accept a 0-10(VDC) modulating input signal from a boiler reset module controller and send this signal to the Vitodens 100 with OpenTherm communication.

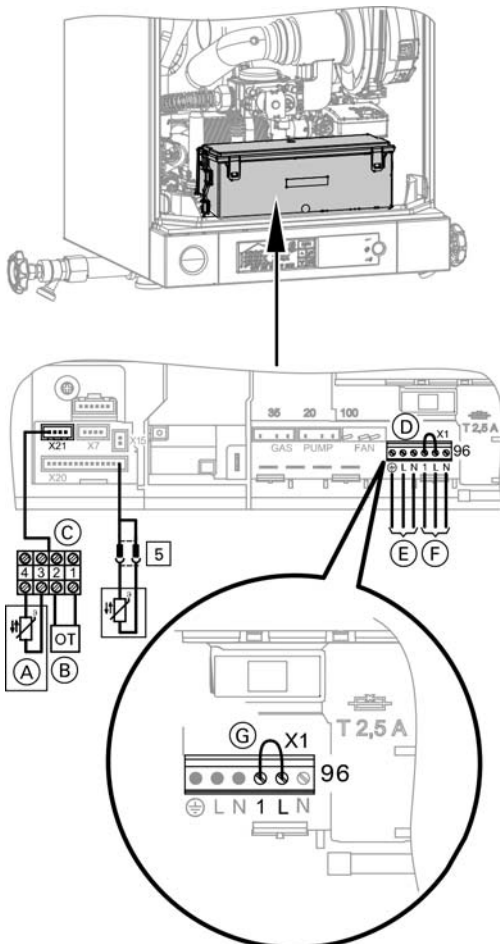

### Legend

- (A) Viessmann outdoor temperature sensor (OTS) (field wiring)
- (B) OpenTherm (OT) 0-10V (field wiring)
- (C) Connection cable terminal
- (D) Power terminal block 120V
- (E) Power supply 120V
- (F) Power supply accessories 120V
- (G) Jumper\*
- 5 DHW tank temperature sensor (B1HA only) or aquastat



\* When using the operating methods 'operation without room temperature thermostat' or 'weather compensated operation without room temperature thermostat' and once jumper (G) is installed, on terminal 96 'L' and '1', refer to the operating instructions.



**Technical Data**

**Call for heat priority logic table**

The Vitodens 100-W, B1HA /B1KA boilers has several operating control options. The following table provides the priority levels of each of the different operating controllers.

Priority	Control operating mode	Required signal *1	Pump output	Pump off delay
1	Freeze protection	Boiler temperature < 41°F (5°C)	On	4 minutes (240 seconds)
2	OpenTherm (OT)	Open Therm (OT) signal / room thermostat	On	20 seconds
3	Combi (B1KA only)	DHW flow sensor / temp. sensor	On	none
4	DHW (B1HA only)	DHW temperature sensor reading drops below set point. Close DHW contact in control (aquastat). - boiler set-point temp. = 172°F (78°C) (non-adjustable)	On	20 seconds
5	Outdoor temperature sensor (OTS)*2	- Temperature “  IIII” setting - 96 plug terminals dual L and I jumpered.	On	4 minutes (240 seconds)
6	Set point temperature operation	Close  contact in control. 96 plug terminals dual L and I jumpered.	On	4 minutes (240 seconds)

\*1 Boiler control will adjust the boiler water temperature set-point to the highest of all input signals.

\*2 Priority #5 and #6 (outdoor temperature sensor contact) not functional when OT inputs are recognized by the boiler control.

**Technical Data** *(continued)*

**Standard heating boiler**

		<b>Boiler Model No.</b>	<b>B1HA 26</b>	<b>B1HA 35</b>	<b>B1KA 35</b>
<b>CSA input Natural gas (NG)</b>	MBH		21-94	21-125	21-125
	kW		6.2-27.5	6.2-36.6	6.2-36.6
<b>CSA input Liquid propane Gas (LPG)</b>	MBH		31-94	31-125	31-125
	kW		9.1-27.5	9.1-36.6	9.1-36.6
<b>CSA output/DOE <sup>1</sup> heating capacity NG</b>	MBH		20-87	20-116	20-116
	kW		5.7-25.6	5.7-34.1	5.7-34.1
<b>CSA output/DOE <sup>1</sup> heating capacity LPG</b>	MBH		29-87	29-116	29-116
	kW		8.4-25.6	8.4-34.1	8.4-34.1
<b>Net AHRI rating <sup>2</sup></b>	MBH		76	101	101
<b>Heat exchanger surface area</b>	ft. <sup>2</sup>		12.96	12.96	12.96
	m <sup>2</sup>		1.2	1.2	1.2
<b>Min. gas supply pressure</b>					
Natural gas	"w.c.		4	4	4
LPG	"w.c.		10	10	10
<b>Max. gas supply pressure <sup>3</sup></b>					
Natural gas and LPG	"w.c.		14	14	14
<b>A.F.U.E.</b>	%		95.0	95.0	95.0
<b>Weight</b>	lbs		79.4	79.4	90.0
	kg		36	36	41
<b>Shipping weight</b>	lbs		88.2	88.2	99.2
	kg		40	40	45
<b>Boiler water content</b>	USG		1.02	1.02	1.02
	L		3.88	3.88	3.88
<b>Boiler max. flow rate <sup>4</sup></b>	GPM		6.2	6.2	6.2
	L/h		1400	1400	1400
<b>Max. operating pressure</b> (max. allowable working pressure) at 210°F (99°C)	psig		45	45	45
	bar		3	3	3
<b>Boiler water temperature</b>					
- Adjustable high limit (AHL) range			86 to 176 (30 to 80)		
- space heating (steady state)	°F (°C)				
- DHW production (set-point)	°F (°C)				
- Fixed high limit (FHL)		°F (°C)	210 (99)		
<b>Boiler connections</b>					
Boiler heating supply and return	NPTM (male)		¾ in.	¾ in.	¾ in.
Pressure relief valve	NPTF (female)		¾ in.	¾ in.	¾ in.
DHW tank heating supply/return	NPTM (male)		¾ in.	¾ in.	--
DHW heating	NPTM (male)		--	--	½ in.
Drain valve	(male thread)		¾ in.	¾ in.	¾ in.
<b>Dimensions</b>					
Overall depth	inches		15¾	15¾	15¾
	(mm)		(400)	(400)	(400)
Overall width	inches		15¾	15¾	15¾
	(mm)		(400)	(400)	(400)
Overall height	inches		30¼	30¼	30¼
	(mm)		(768)	(768)	(768)

<sup>1</sup> Output based on 140°F (60°C), 120°F (49°C) system supply / return temperature.

<sup>2</sup> Net AHRI rating based on piping and pick-up allowance of 1.15.

<sup>3</sup> If the gas supply pressure exceeds the maximum gas supply pressure value, a separate gas pressure regulator must be installed upstream of the heating system.

<sup>4</sup> See "System Flow Rates" on pages 25 and 26 in this manual.

**Technical Data** *(continued)*

**Standard heating boiler** *(continued)*

Boiler Model No.		B1HA 26	B1HA 35	B1KA 35
<b>Gas supply connection</b>	NPTM (male)	¾ in.	¾ in.	¾ in.
<b>Flue gas 5</b>				
Temperature at boiler return temperature of 86°F (30°C)				
- at rated full load	°F (°C)	113 (45)	113 (45)	113 (45)
- at rated partial load	°F (°C)	95 (35)	95 (35)	95 (35)
Temperature at boiler return temperature of 140°F (60°C)				
	°F (°C)	167 (75)	172 (78)	172 (78)
<b>Flue gas value</b>				
Mass flow rate (of flue gas)				
- at rated full load	lbs/h	79.2	100.1	100.1
	kg/h	36.0	45.5	45.5
- at rated partial load	lbs/h	33.0	33.0	33.0
	kg/h	15.0	15.0	15.0
Available draught	Pa	100	100	100
	mbar	1.0	1.0	1.0
<b>Flue gas temperature sensor limit</b>	°F (°C)	230 (110)	230 (110)	230 (110)
<b>Average condensate flow rate 6</b>				
with natural gas				
- Ts/TR = 122 / 86°F (50 / 30°C)	USG/day	1.95-2.3	2.5-2.8	2.5-2.8
	L/day	8-9	9.4-10.5	9.4-10.5
<b>Condensate connection 7</b>	hose nozzle Ø in	1	1	1
<b>Boiler flue gas connection 8</b>	Ø in (mm)	2¾ (60)	2¾ (60)	2¾ (60)
<b>Combustion air supply connection 8</b>	coaxial outer Ø in (mm)	4 (100)	4 (100)	4 (100)
	single	2¾ (60)	2¾ (60)	2¾ (60)
<b>Noise level (at 1 meter)</b>				
- at full load	(dB)	46.9	51.6	51.6
- at partial load	(dB)	41.1	41.1	41.1
<b>High altitude (factory set) 9</b>	ft. (m)	0-5,000 (0-1,500)		

5 Measured flue gas temperature with a combustion air temperature of 68°F (20°C).

6 Based on typical boiler cycles, including partial load conditions.

7 Requires 1 in. (25 mm) tubing. See Vitodens 100-W Installation Instructions for details.

8 For detailed information refer to the Vitodens Venting System Installation Instructions.

9 For 5,000 to 10,000 ft. (1,500 to 3,000 m) operation, a control programming change is required. Refer to the Installation and Service Instructions for details.

**Note:** For altitude operation up to 4,999 feet, derate the input capacity by 3%/1000 ft. (305 m).

For operation from 5,000 to 10,000 ft. (1,500 to 3,000 m), with the electronic altitude adjustment made, derate the input capacity by 3% for every 1000 ft. (305 m) starting at 5000 ft. (1,500 m) for a total of 15%.

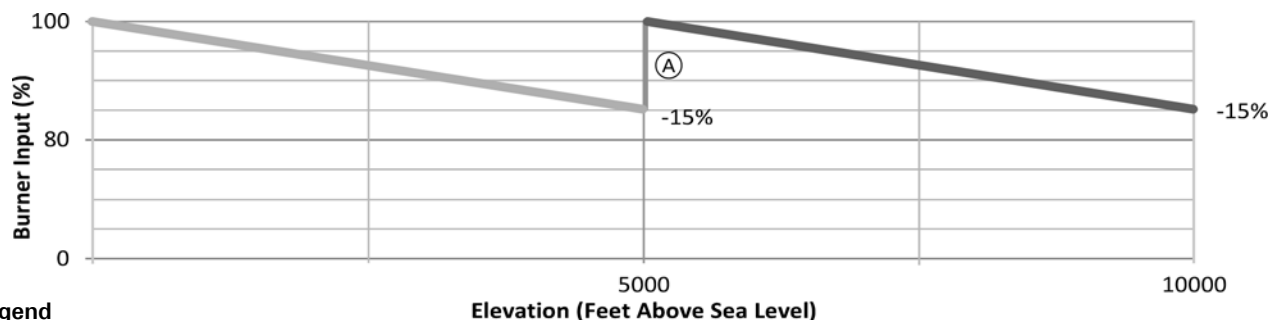

**Legend**

Ⓐ Input capacity after electronic altitude adjustment is made.

**Technical Data** *(continued)***B1KA on demand hot water operation**

	<b>Boiler Model No.</b>	<b>B1KA 35</b>
<b>Max. Input NG and LPG</b> (DHW production only)	MBH	149
	kW	43.7
<b>Max. boiler temperature</b> (during DHW production)	°F (°C)	176 (80)
<b>DHW supply temperature</b>	°F (°C)	140 (60)
<b>Continuous draw rate * 1</b> at $\Delta t = 77^{\circ}\text{F}$ (43K)	USG/min.	3.3
	L/h	750
<b>Max. flow through heat exchanger</b>	USG/min.	3.7
	L/h	840
<b>Maximum allowable working pressure</b> (potable water)	psi	150
<b>Test pressure</b>	psi	300
<b>Integrated pump flow rate</b> DHW production @ 23 ft. (9.8 m) Head pressure	USG/min.	5.63
	L/h	1278
<b>Heating system operation</b> with system side additional drop in pressure of max. 6 ft. of water (1.8 m)	USG/min.	6.2
	L/h	1408

\*1 DCW and DHW temperature rise would be proportional. Maximum DHW supply temperature is 140°F (60°C).

## Burner Program Sequence of Operation

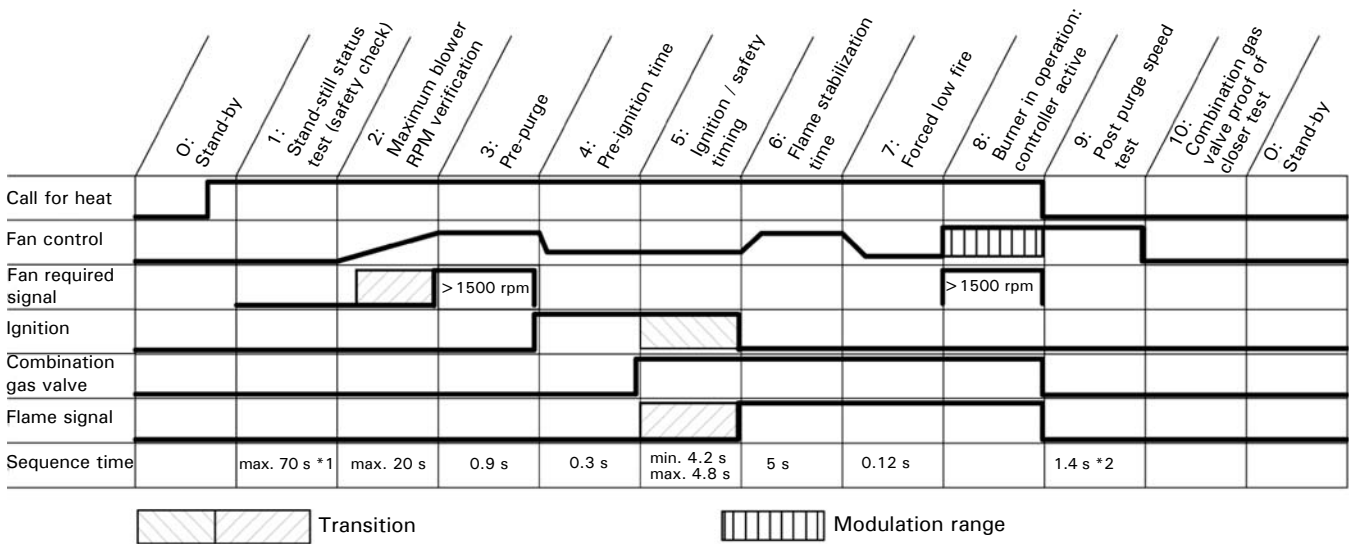

\*1 50 seconds for no flame present check and 20 seconds for blower stand-stil check (total 70 seconds).

\*2 20 second fan operation if flame failure is detected.

Phase	Explanation	End of sequence
0	Stand by	Continue to next phase
1	Stand-still status test (safety check)	Safety shutdown
2	Maximum blower RPM verification	Continue to next phase
3	Pre-purge	Continue to next phase
4	Pre-ignition time	Retrial for ignition or safety shutdown
5	Ignition / safety timing	Continue to next phase
6	Flame stabilization time	Continue to next phase
7	Forced low-fire	Continue to next phase
8	Burner in operation: controller active	Continue, or if FHL tripped, 15 minute forced fan operation
9	Post-purge	Continue to next phase
10	Combination gas valve proof of closure test	Continue to next phase
0	Boiler shutdown / stand-by	Waiting for next call for heat

**Burner Program Sequence of Operation** *(continued)***Phase 0: Stand by**

Complete shutdown until the next call for heat. In this phase both the combination gas valve and the blower are not energized.

**Phase 1: Stand-still status test (blower)**

A call for heat initiates internal blower sensory communications to confirm that the blower is truly in stand-still position. Blower speed measured must be < 300 rpm within a 70 second period.

**Phase 2: Pre-purge speed test**

Controller sends and receives signal to / from fan speed controller to verify maximum rpm of the blower.

**Phase 3: Pre-purge**

Pre-purge cycle starts within the pre-programmed timing. Pre-purge timing is in addition to previous phase (2). The fan speed must be greater than 1500 rpm.

**Phase 4: Pre-ignition**

The ignition spark is initiated and controlled.

**Phase 5: Ignition / safety timing**

The gas valve opens during the safety timing period (4.8 sec.). If a flame is detected, this phase ends immediately in < 4.8 sec. If the flame is not established after 3 trials, the burner will lock out and will require a manual reset.

**Phase 6: Flame stabilization**

Controller required time for flame stabilization.

**Phase 7: Forced low-fire**

The controller will go into low-fire until required modulation signal (high-low) is processed (e.g. boiler actual water temperature).

**Phase 8: Burner operation**

At the end of the flame stabilization period (5 sec.), a release for modulation occurs and the burner temperature controller will take over from the flame safeguard. Forced shutdown after 24 hours continuous operation.

**Phase 9: Post-purge speed test**

Both gas valves are closed during this phase. End call for heat.

Post-purge occurs during the programmed period. If the fixed high limit trips during normal operation, the blower will purge for 15 minutes to cool the heat exchanger.

**Phase 10: Combination gas valve proof of closure test**

If during the normal operation of the burner a controlled (or uncontrolled) shut-down occurs, a complete mechanical and electrical gas valve proof of closure test will be performed by the flame safeguard. After a successful mechanical and electrical proof of closure test, the flame safeguard will expect that the flame is not present. If, however, the flame existed for a period of >30 seconds, the flame safeguard will go into permanent lock-out.

# B1HA 26, 35 Wiring Diagram

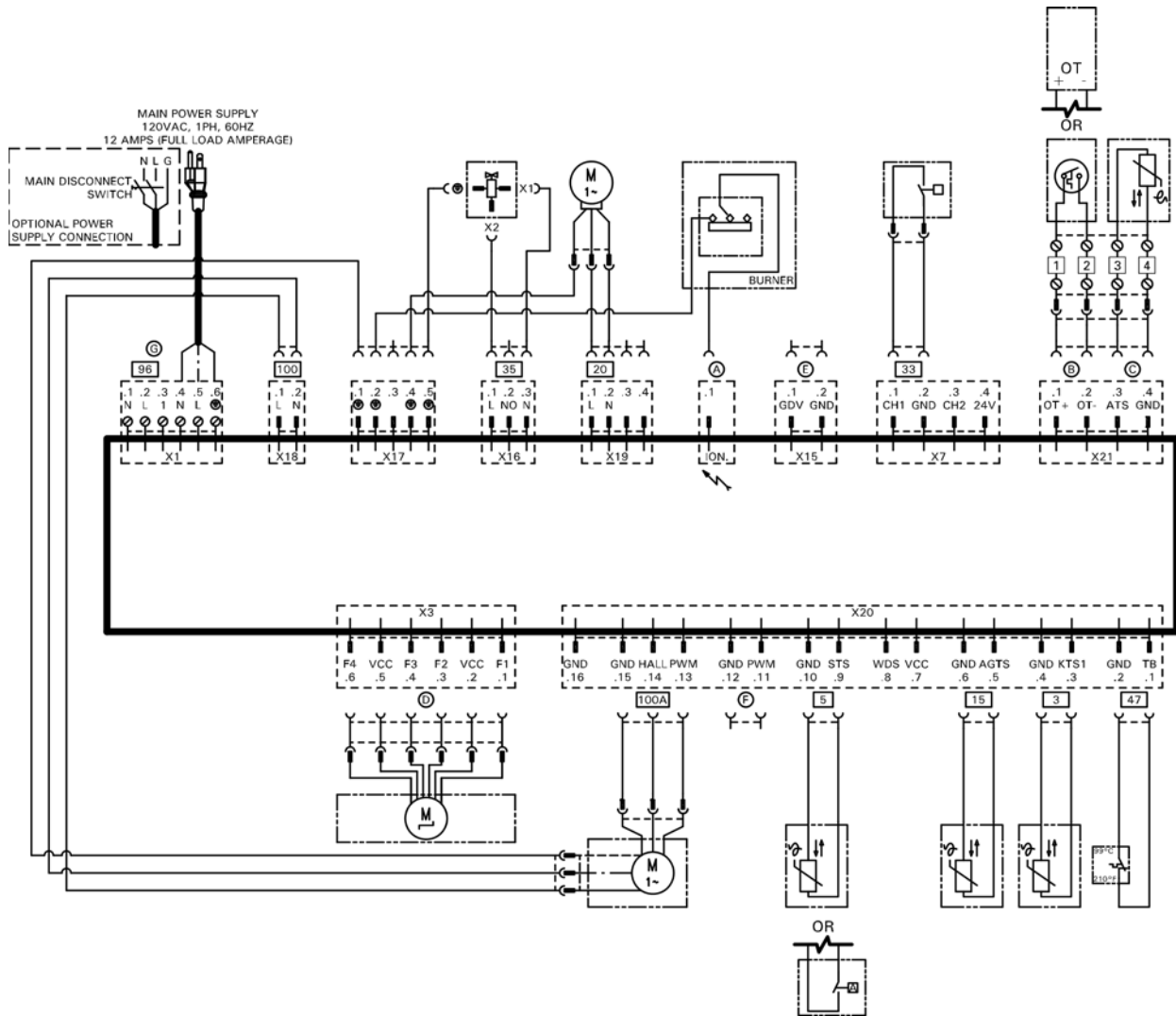

**Legend**

- (A) Ignition/ionization
- (B) Room thermostat (dry contact) or OpenTherm (OT) Interface input
- (C) Outdoor Temperature Sensor (OTS)
- (D) Diverting valve stepping motor
- (E) GDW input (not used)
- (F) PWM pump output (not used)
- (G) Powered accessory connection or 120VAC room thermostat (RT)

3	Boiler Temperature Sensor
5	DHW Tank Temperature Sensor
15	Flue Gas temperature Sensor
20	Boiler Pump (internal)
33	Flow Switch
35	Gas Valve
47	Fixed High Limit
100	Fan Motor
100A	Fan Motor Control

**WARNING**  
**DISCONNECT POWER BEFORE SERVICING BOILER.**

**CAUTION**  
 Label all wires prior to disconnection when servicing controls. Wiring errors can cause improper and dangerous operation. Verify proper operation after servicing.

If any of the original wires as supplied with the appliance must be replaced, it must be replaced with the exact equivalent.

Electrical Installations must comply with:  
 In the USA National Electric Code (NEC), ANSI/NFPA 70 and any other national, state and local codes and/or regulations.  
 In Canada, the Canadian Electrical Code (CEC), CSA C22.1 Canadian Electrical Code Part 1 and any other province, territory, local codes and/or regulations.

5784 568 - 02

# B1KA 35 Wiring Diagram

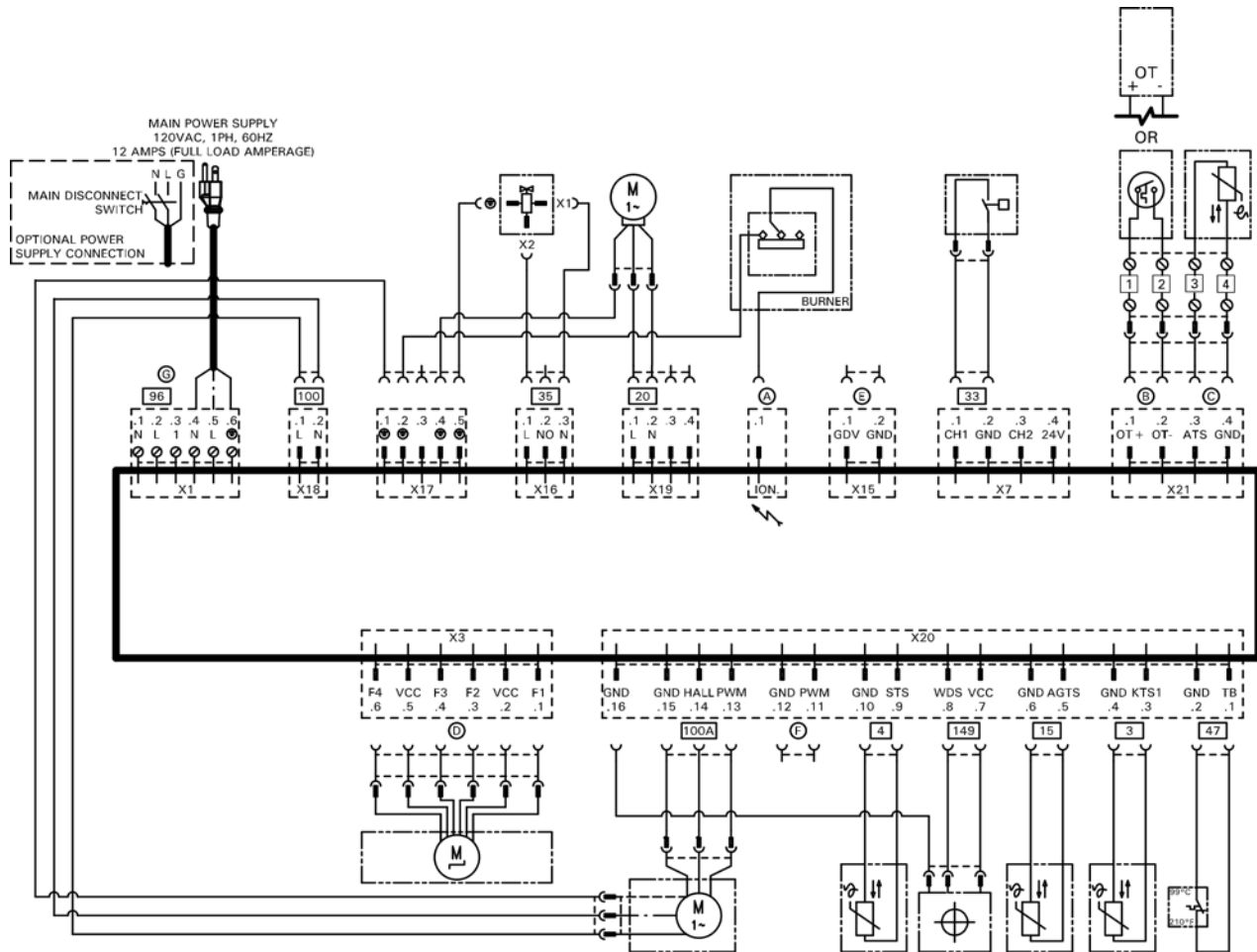

**Legend**

- (A) Ignition/ionization
- (B) Room thermostat (dry contact) or OpenTherm (OT) Interface input
- (C) Outdoor Temperature Sensor (OTS)
- (D) Diverting valve stepping motor
- (E) GDW input (not used)
- (F) PWM pump output (not used)
- (G) Powered accessory connection or 120VAC room thermostat (RT)

3	Boiler Temperature Sensor
4	DHW Supply Temperature Sensor
15	Flue Gas temperature Sensor
20	Boiler Pump (internal)
33	Flow Switch
35	Gas Valve
47	Fixed High Limit
100	Fan Motor
100A	Fan Motor Control
149	Flow Sensor (DHW)

**WARNING**  
**DISCONNECT POWER BEFORE SERVICING BOILER.**

**CAUTION**  
 Label all wires prior to disconnection when servicing controls. Wiring errors can cause improper and dangerous operation. Verify proper operation after servicing.

If any of the original wires as supplied with the appliance must be replaced, it must be replaced with the exact equivalent.

Electrical Installations must comply with:  
 In the USA National Electric Code (NEC), ANSI/NFPA 70 and any other national, state and local codes and/or regulations.  
 In Canada, the Canadian Electrical Code (CEC), CSA C22.1 Canadian Electrical Code Part 1 and any other province, territory, local codes and/or regulations.



# Parts List

<b>Model No.</b>	<b>Serial No.</b>
B1HA 26 Boiler	7560853□□□□□□□□
B1HA 35 Boiler	7560854□□□□□□□□

**Ordering Parts:**

Please provide Serial Number (A) when ordering replacement parts. Order replacement components from your Viessmann distributor.

**Overview of Assemblies**

- (A) Serial Number \* 1
- (B) Main Enclosure Assembly
- (C) Boiler and Burner Assembly
- (D) Control Assembly
- (E) Hydraulic and Combi Block Assembly
- (F) Other Parts

\* 1 Serial number is located inside main enclosure assembly, behind boiler cover panel on left-hand side.

**Other Parts (not illustrated)**

- 0100 Installation Set \* 2
- 0125 Technical literature set
- 0128 Installation/Service Instructions
- 0130 Operating Instructions
- 0132 Installation Instructions, Venting System
- 0133 Parts List, Vitodens 100-W
- 0134 Parts List, Installation Set
- 0135 Wiring Diagram
- 0137 Warranty Sheet
- 0138 Technical Data Manual
- 0150 Conversion Kit, NG > LP
- 0151 Conversion Kit, LP > NG

\* 2 For Installation Set please see separate Parts Lists.

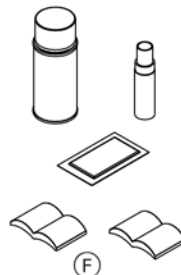
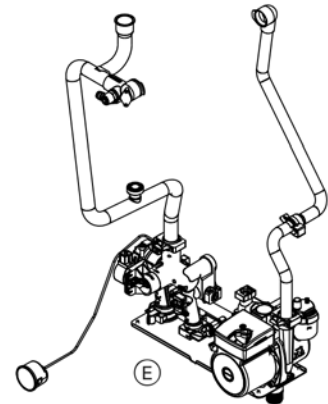
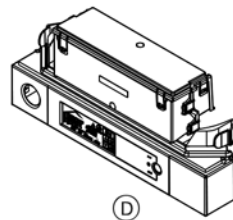
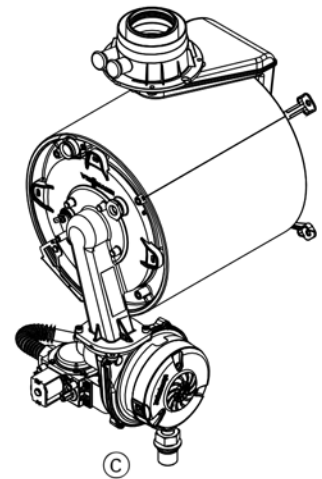
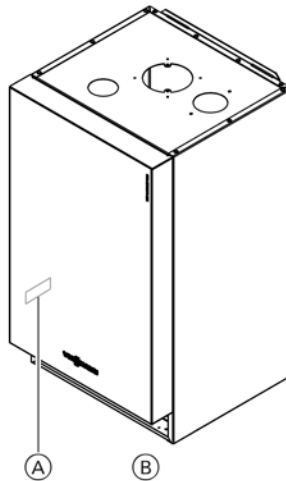

**Parts List** *(continued)*

**Model No.** B1KA 35 Boiler  
**Serial No.** 7560855□□□□□□□□

Ordering Parts:  
 Please provide Serial Number (A) when ordering replacement parts. Order replacement components from your Viessmann distributor.

**Overview of Assemblies**

- (A) Serial Number \*1
- (B) Main Enclosure Assembly
- (C) Boiler and Burner Assembly
- (D) Control Assembly
- (E) Hydraulic and Combi Block Assembly
- (F) Other Parts

\*1 Serial number is located inside main enclosure assembly, behind boiler cover panel on left-hand side.

**Other Parts** (not illustrated)

- 0100 Installation Set \*2
- 0125 Technical literature set
- 0128 Installation/Service Instructions
- 0130 Operating Instructions
- 0132 Installation Instructions, Venting System
- 0133 Parts List, Vitodens 100-W
- 0134 Parts List, Installation Set
- 0135 Wiring Diagram
- 0137 Warranty Sheet
- 0138 Technical Data Manual
- 0150 Conversion Kit, NG > LP
- 0151 Conversion Kit, LP > NG

\*2 For Installation Set please see separate Parts Lists.

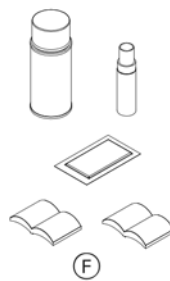
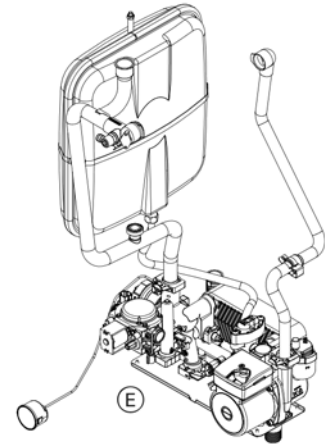
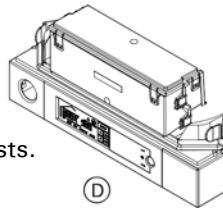
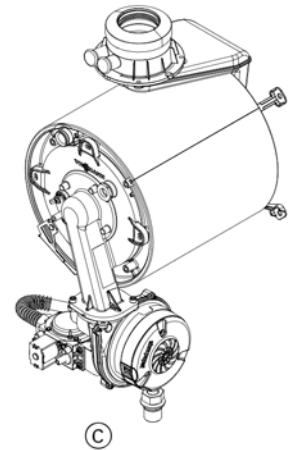
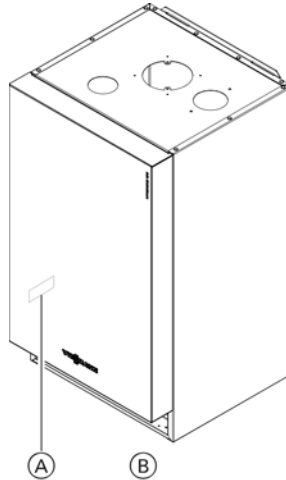

**Parts List** *(continued)*

Model No.	Serial No.
B1HA 26 Boiler	7560853□□□□□□□□
B1HA 35 Boiler	7560854□□□□□□□□
B1KA 35 Boiler	7560855□□□□□□□□

**Parts for Main Enclosure Assembly**

- 0001 Cover panel, boiler
- 0002 Profile gasket for cover panel
- 0003 Nameplate "Viessmann"
- 0004 Strain relief, top
- 0005 Base panel, air box
- 0006 Sealing grommet (set)
- 0007 Wall-mount bracket
- 0008 Nameplate "Vitodens 100"
- 0009 Sealing grommet (each)

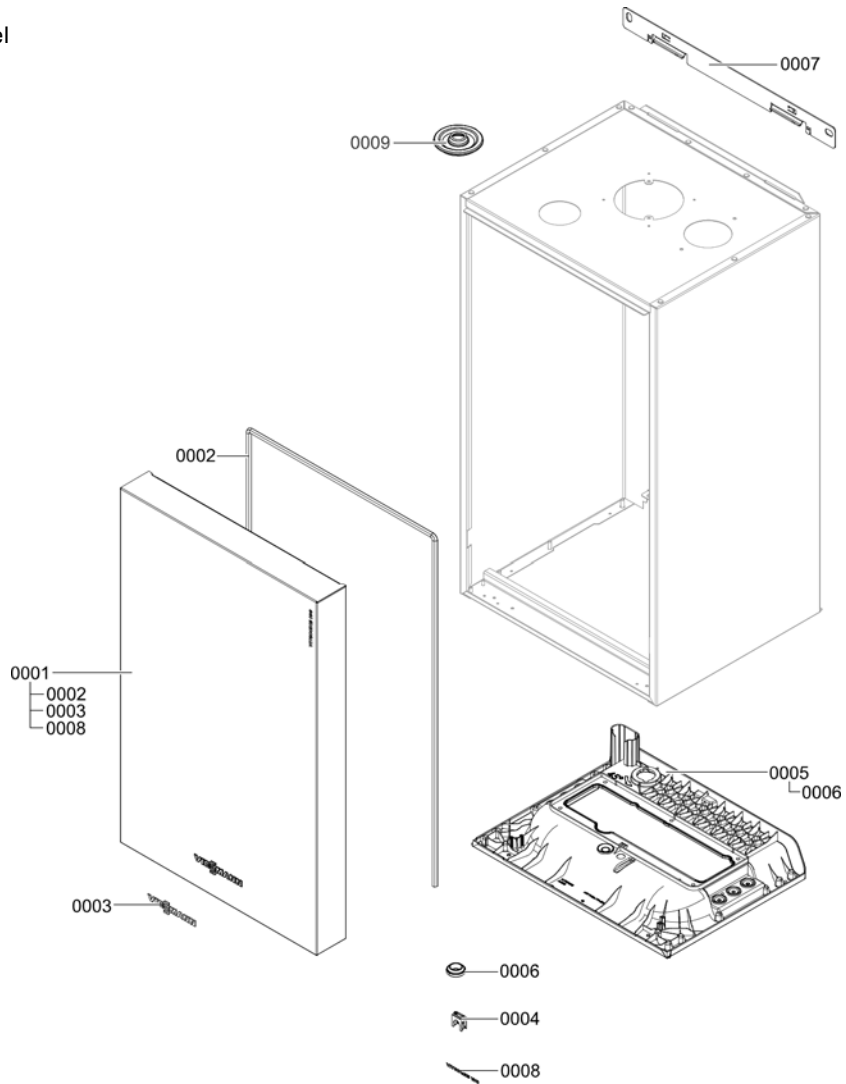

**Parts List** *(continued)*

<b>Model No.</b>	<b>Serial No.</b>
B1HA 26 Boiler	7560853□□□□□□□□
B1HA 35 Boiler	7560854□□□□□□□□
B1KA 35 Boiler	7560855□□□□□□□□

**Parts for Boiler Assembly**

- 0001 Gasket for flue gas, DN60
- 0002 Vent pipe adaptor, 60/100
- 0003 Test port cap (set of 2)
- 0004 Sealing grommet, DN60
- 0005 Sensor for flue gas
- 0006 Heat exchanger assembly, ASME
- 0007 Condensate pipe
- 0008 Condensate P-trap
- 0009 Extension, P-trap
- 0010 Fuel connection pipe, NG/LP
- 0011 Gasket set, A17x24x2 (set of 5)
- 0013 Combustion chamber refractory
- 0014 Flue baffle
- 0015 Support bracket set for heat exchanger
- 0016 O-Ring set, 21x3 mm for heat exchanger
- 0017 Gasket for flue elbow
- 0018 Condensate pipe, 19 x 800 mm
- 0019 Flue gas collector with elbow
- 0020 Flue elbow
- 0021 Air intake cover

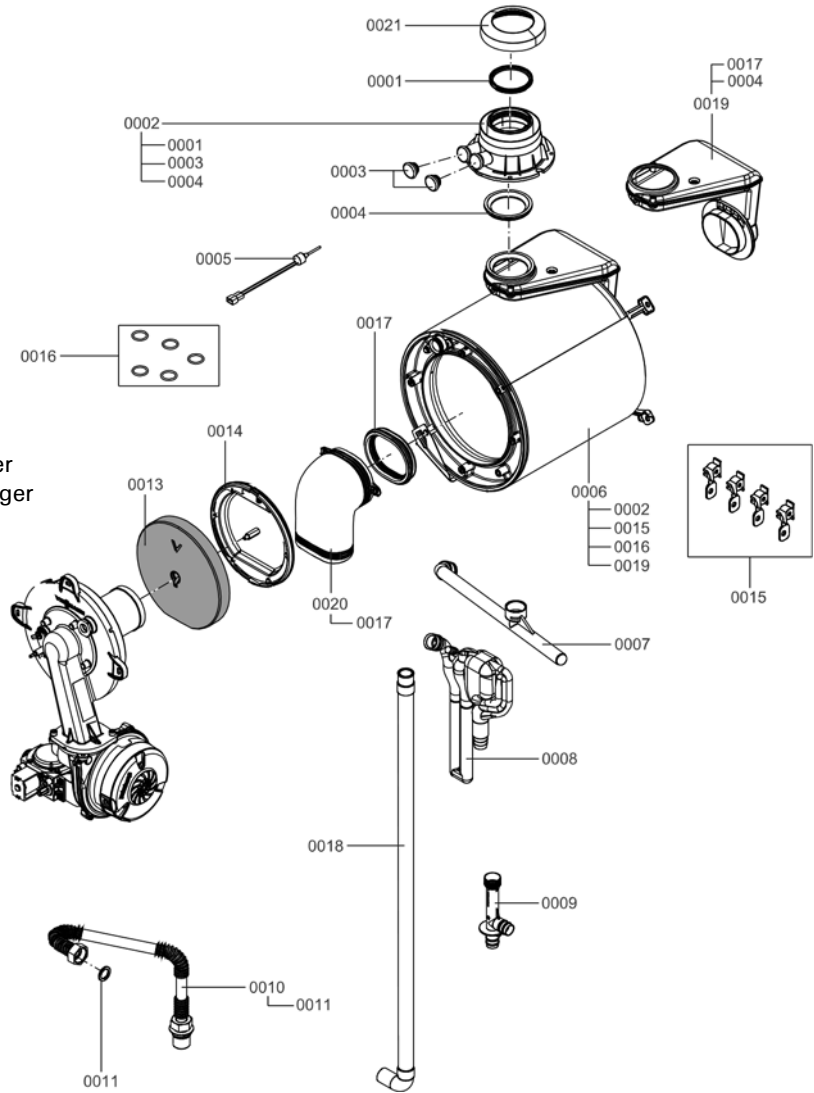

**Parts List** *(continued)*

Model No.	Serial No.
B1HA 26 Boiler	7560853□□□□□□□□
B1HA 35 Boiler	7560854□□□□□□□□
B1KA 35 Boiler	7560855□□□□□□□□

**Parts for Burner Assembly**

- 0001 Burner gasket, 187x5.5 mm
- 0002 Insulating ring
- 0003 Burner tube
- 0004 Gasket for burner tube
- 0005 Burner mounting flange assembly
- 0006 Gasket for electrode block
- 0007 Ignition + ionization electrode block
- 0008 Gasket for radial fan
- 0009 Radial fan, NRG118
- 0010 Gas valve, GB-ND 055 E01
- 0011 Bracket (set of 2)
- 0012 Venturi extension
- 0013 Gaskets NG/LP (set of 5)
- 0014 Conversion kit, NG > LP

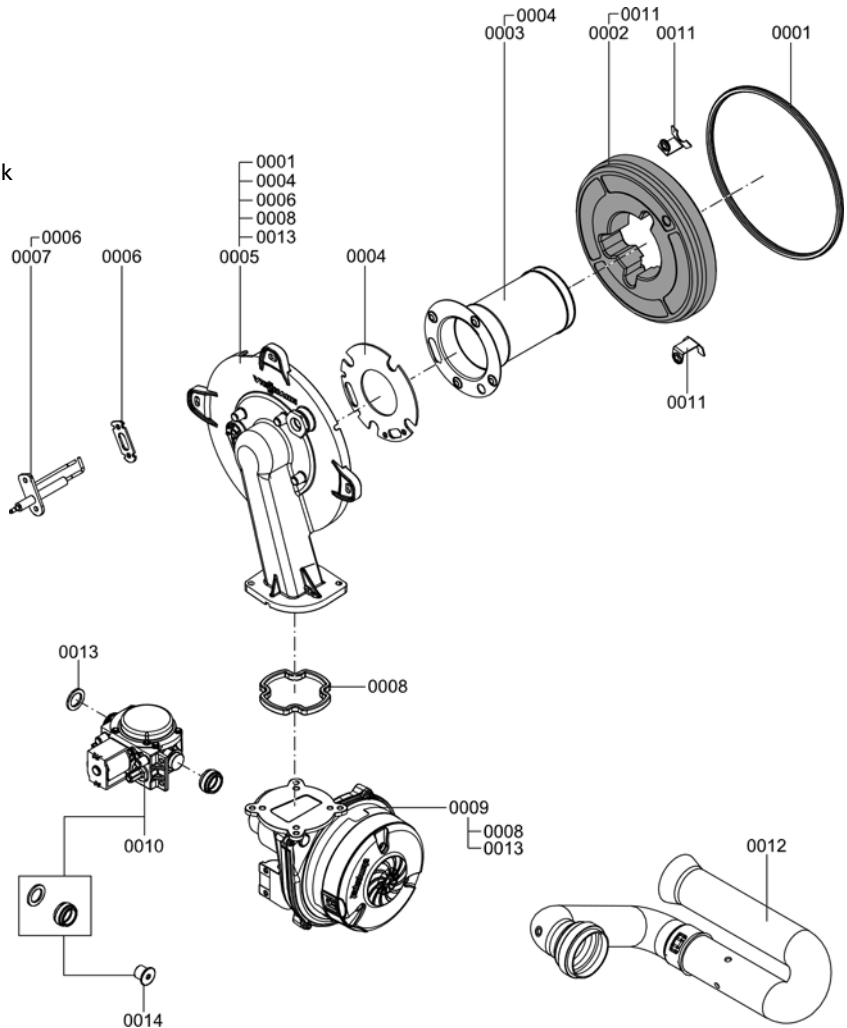

**Parts List** *(continued)*

<b>Model No.</b>	<b>Serial No.</b>
B1HA 26 Boiler	7560853□□□□□□□□
B1HA 35 Boiler	7560854□□□□□□□□

**Parts for Hydraulic Assembly**

- 0001 Connection pipe for heating return
- 0002 Clip, d = 10 (set of 5)
- 0003 Clip, d = 8 (set of 5)
- 0004 O-ring set for heat exchanger, 21x3 mm
- 0005 Air bleed valve, G3/8
- 0006 Sensor #3 (boiler)
- 0007 O-ring, 8x2 mm (set of 5)
- 0008 Connection pipe for heating supply
- 0009 Clip, d = 18 (set of 5)
- 0010 O-ring, 17x4 mm (set of 5)
- 0011 Pressure gage (psi)
- 0012 Fixed high limit, 210°F (99°C)
- 0013 Bleeding hose, 10x1.5x1500 mm
- 0014 O-ring, 17.86x2.62 mm (5 pieces)

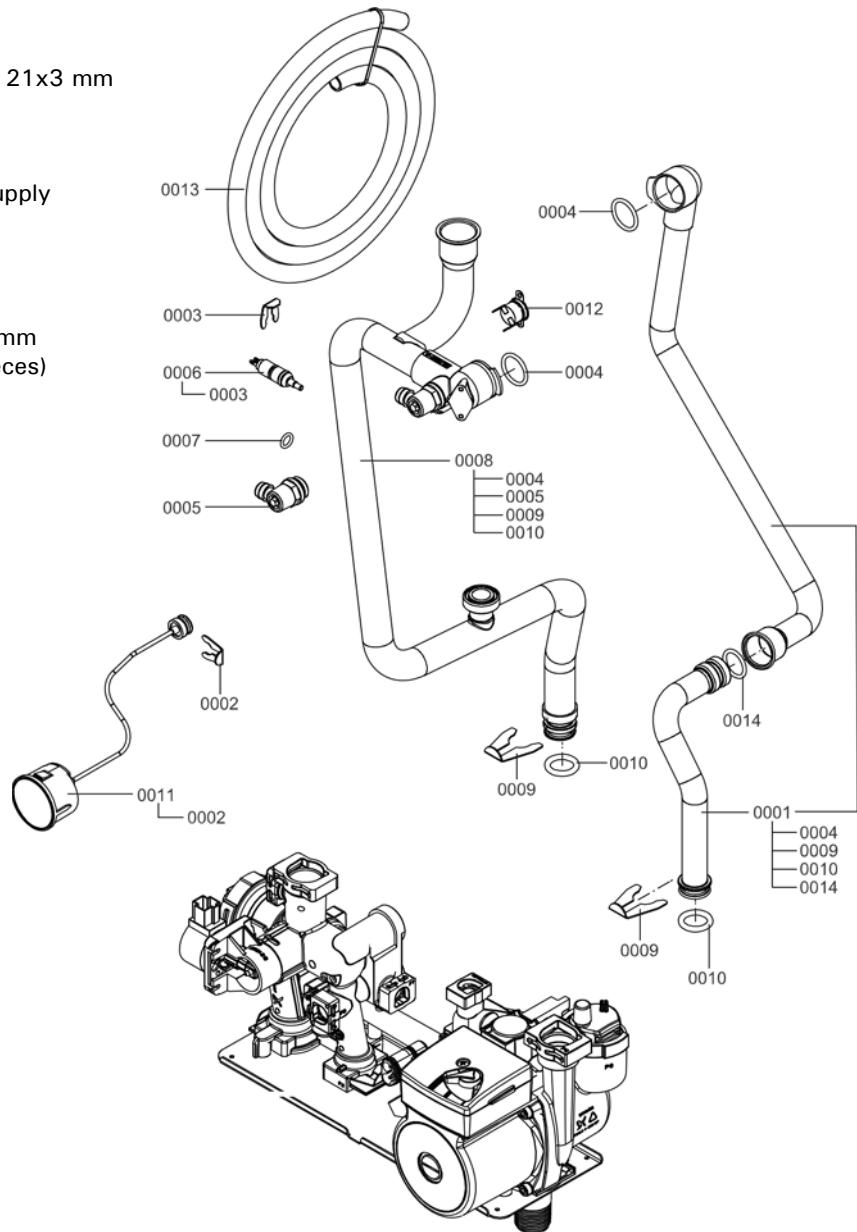

**Parts List** *(continued)*

**Model No.** B1KA 35 Boiler      **Serial No.** 7560855□□□□□□□□

**Parts for Hydraulic Assembly**

- 0001 Connection pipe for heating return
- 0002 Clip, d = 10 (set of 5)
- 0003 Clip, d = 8 (set of 5)
- 0004 O-ring set for heat exchanger, 21x3 mm
- 0005 Air bleed valve, G3/8
- 0006 Sensor #3 (boiler)
- 0007 O-ring 8x2 mm (set of 5)
- 0008 Connection pipe for heating supply
- 0009 Clip d = 18 (set of 5)
- 0010 O-ring 17x4 mm (set of 5)
- 0011 Pressure gage (psi)
- 0012 Fixed high limit, 210°F (99°C)
- 0013 Bleeding hose, 10x1.5x1500 mm
- 0014 O-ring 17.86x2.62 mm (5 pieces)
- 0016 Expansion tank, CRI 8
- 0017 Hose clamp d = 220-240x9 mm
- 0018 Gasket, A10x15x1.5 (set of 5)
- 0019 Flex pipe MAG G3/8 for expansion tank

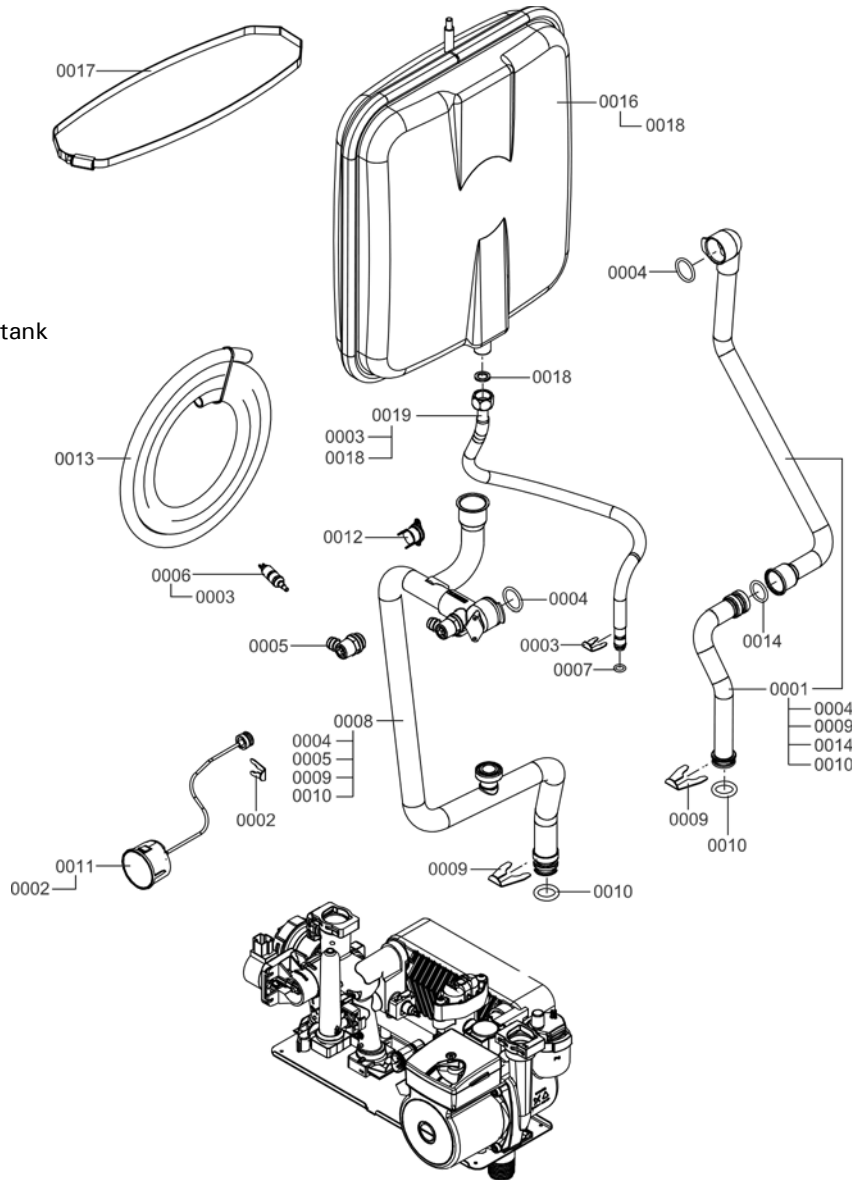

**Parts List** *(continued)*

<b>Model No.</b>	<b>Serial No.</b>
B1HA 26 Boiler	7560853□□□□□□□□
B1HA 35 Boiler	7560854□□□□□□□□

**Parts for Pumping Block Assembly**

- 0001 Air vent
- 0002 O-ring, 34 x 3 mm (5 pieces)
- 0003 Circulation pump head, Grundfos UPS15-78
- 0004 Bypass cartridge
- 0005 Clip D = 16 (set of 5)
- 0006 Adaptor for step motor
- 0007 Step motor (linear)
- 0008 Hydraulic, pumping block
- 0009 O-Ring, 19.8 x 3.6 mm (5 pieces)
- 0010 O-Ring, 16 x 3 mm (5 pieces)
- 0011 Flow check valve, DN15
- 0012 Clip D = 18 (5 pieces)
- 0013 O-Ring, 24.7 x 3.6 mm (5 pieces)
- 0014 Connection nipple set

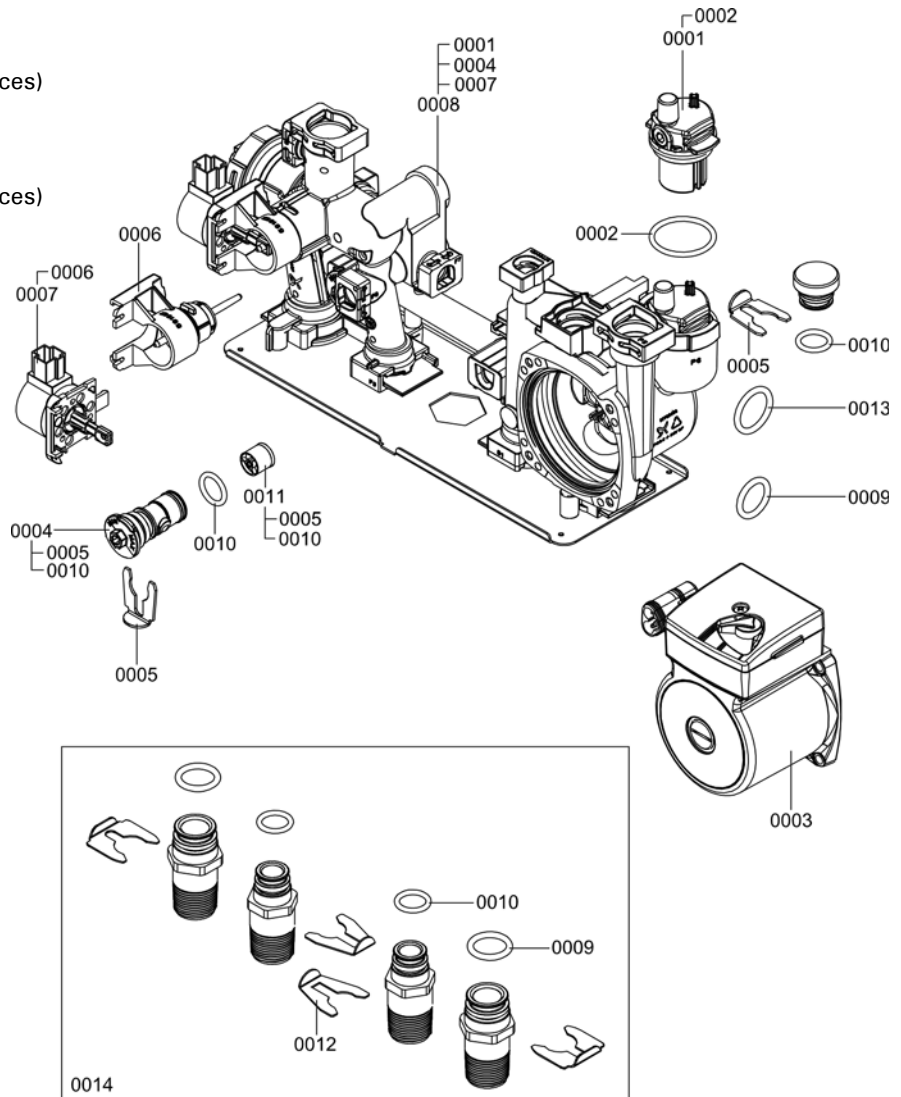



**Parts List** *(continued)*

**Model No.** B1KA 35 Boiler      **Serial No.** 7560855□□□□□□□□

**Parts for Combi Block Assembly**

- 0001 Air vent
- 0002 O-ring 34x3 mm (5 pieces)
- 0003 O-ring 24.7x3.6 mm (5 pieces)
- 0004 Step motor (linear)
- 0005 Bypass cartridge
- 0006 Clip d = 16 (set of 5)
- 0007 Adaptor (step motor)
- 0008 O-ring 19.8 x 3.6 mm (5 pieces)
- 0009 O-ring 16 x 3 mm (5 pieces)
- 0010 Clip d = 18 (set of 5)
- 0011 Clip d = 10 (set of 5)
- 0012 Clip plate D8 slim (5 pieces)
- 0013 Flow regulator (WHT/BRN), Type A 14L
- 0014 Gasket oval (5 pieces)
- 0015 Gasket set for plate heat exchanger
- 0016 Expansion pipe
- 0017 Circulation pump head, Grundfos UPS15-78
- 0018 Plate heat exchanger, 20 plates
- 0019 Hydraulic, Combi block
- 0020 Clip d = 8 (set of 5)
- 0021 Sensor #3
- 0022 Flow sensor
- 0023 Gasket set, 10x2 mm
- 0024 O-ring, 8x2 mm (set of 5)
- 0025 Flow check valve, DN15
- 0026 Connection nipple set

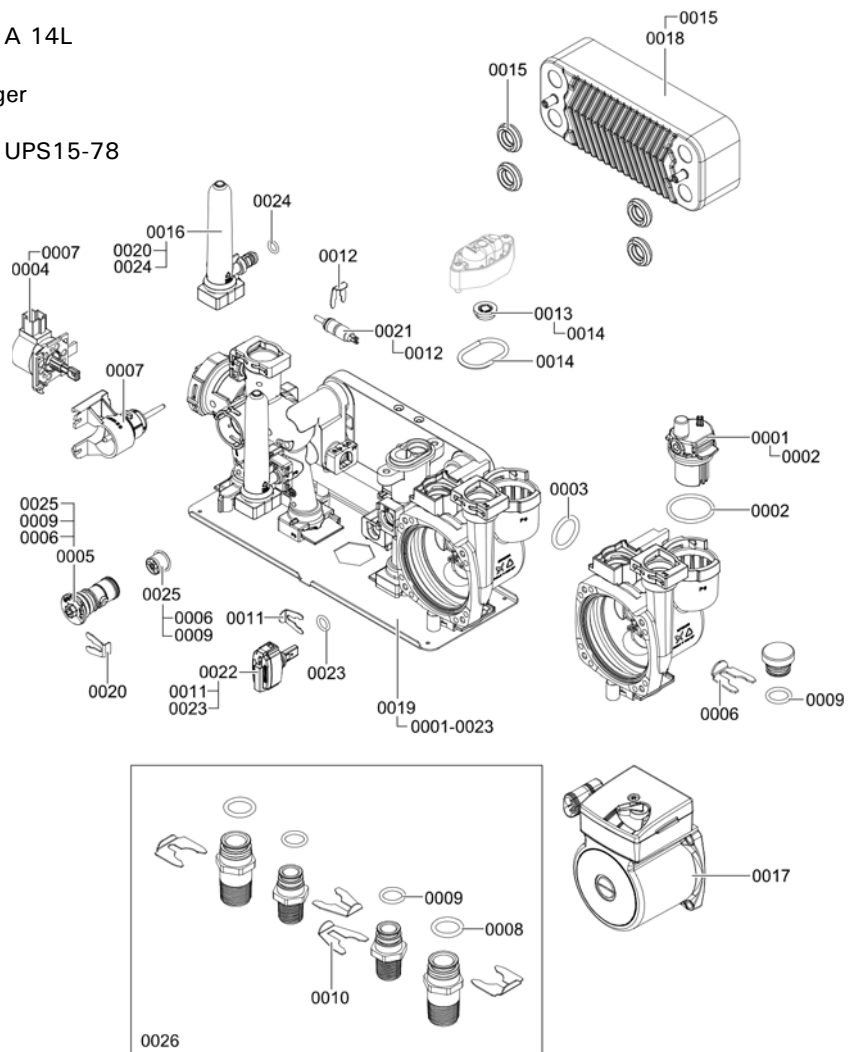

**Parts List** *(continued)*

Model No.	Serial No.
B1HA 26 Boiler	7560853□□□□□□□□
B1HA 35 Boiler	7560854□□□□□□□□
B1KA 35 Boiler	7560855□□□□□□□□

**Parts for Control Assembly**

- 0001 Control console cover
- 0002 Clip hinge (2 pieces)
- 0003 Profile gasket
- 0004 Control console, VBC115-F50
- 0005 Harness X20/X7
- 0006 Ignition cable 5kOhm
- 0007 Harness "35"  
for expanded functions
- 0008 Harness "100" for fan
- 0009 Harness for step motor
- 0010 Fuse, 2.5A/250V (set of 10)
- 0011 Sensor #1 (outdoor, NTC)
- 0012 Harness X21
- 0013 Harness "20" for pump
- 0014 Harness for power

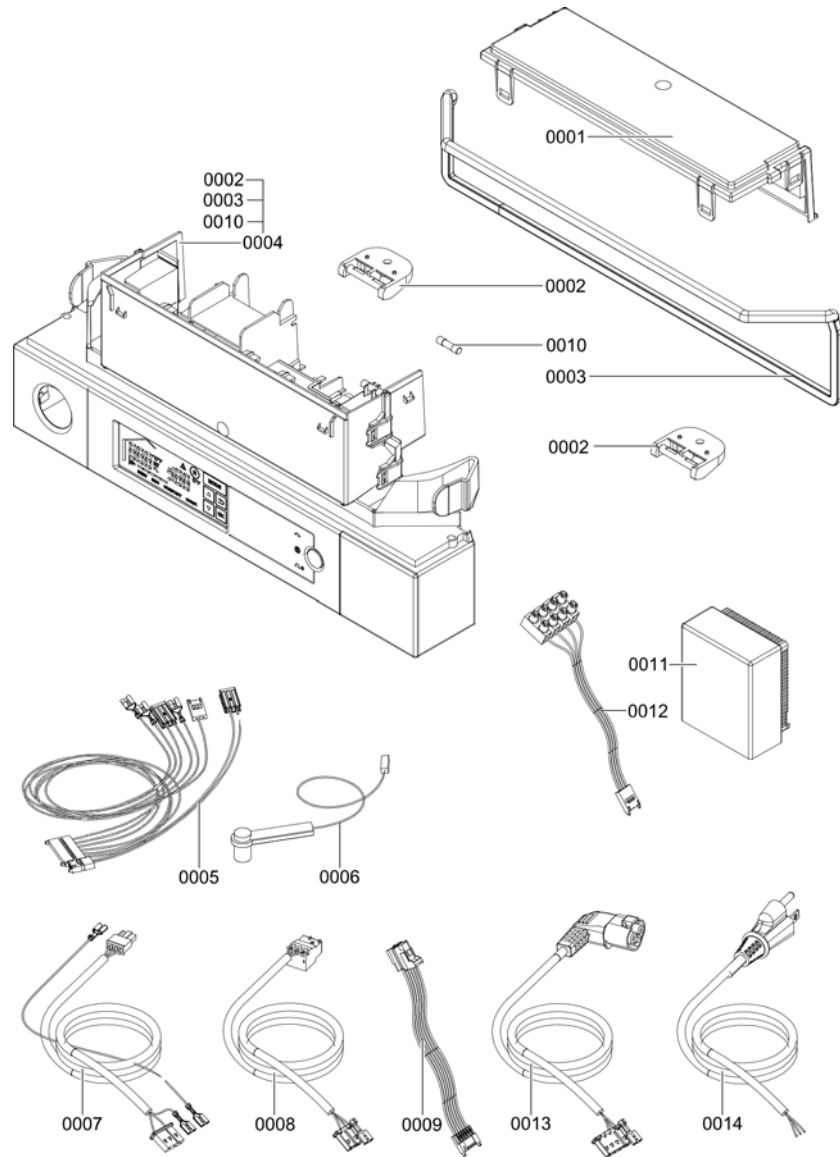

**Parts List** *(continued)*

Model No.	Serial No.
B1HA 26 Boiler	7560853□□□□□□□□
B1HA 35 Boiler	7560854□□□□□□□□
B1KA 35 Boiler	7560855□□□□□□□□

Other Parts

- 0001 Touch-up spray paint "Vitowhite"
- 0002 Touch-up paint stick "Vitowhite"
- 0003 Lubricant 6g

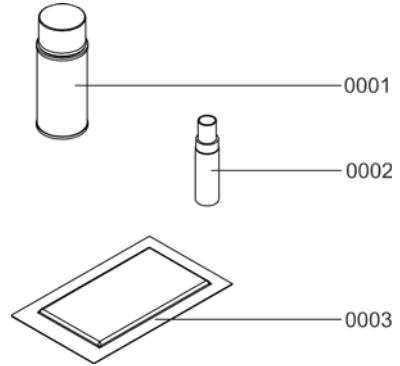

## Installation Fittings

Model No.	Serial No.
B1HA 26 Boiler	7560853□□□□□□□□
B1HA 35 Boiler	7560854□□□□□□□□
B1KA 35 Boiler	7560855□□□□□□□□

**Ordering Parts:**  
Please provide Serial Number A when ordering replacement parts. Order replacement components from your Viessmann distributor.

**Parts**

- 0101 Boiler pressure relief valve, 30 psi
- 0102 Adaptor for pressure relief valve
- 0103 Sediment faucet, 3/4 in.
- 0104 Extension, 3/4 in. x 3 in.
- 0105 Tee, 3/4 in.
- 0106 Gas ball valve, 3/4 in.
- 0107 Thermometer \*1
- 0108 DHW pressure relief valve, 150 psi \*2

**Other Parts** (not illustrated)

- 0109 Outdoor temperature sensor, NTC 10K
- 0110 Accessory pack, metal stud mount kit
- 0133 Parts List, Installation Set

\*1 Install anywhere in supply piping near boiler.  
\*2 These components only ship with Vitodens 100-W B1KA boiler.

(A) Serial number is located inside main enclosure assembly, behind boiler cover panel on left-hand side.

(B) Vitodens boiler see separate Parts List

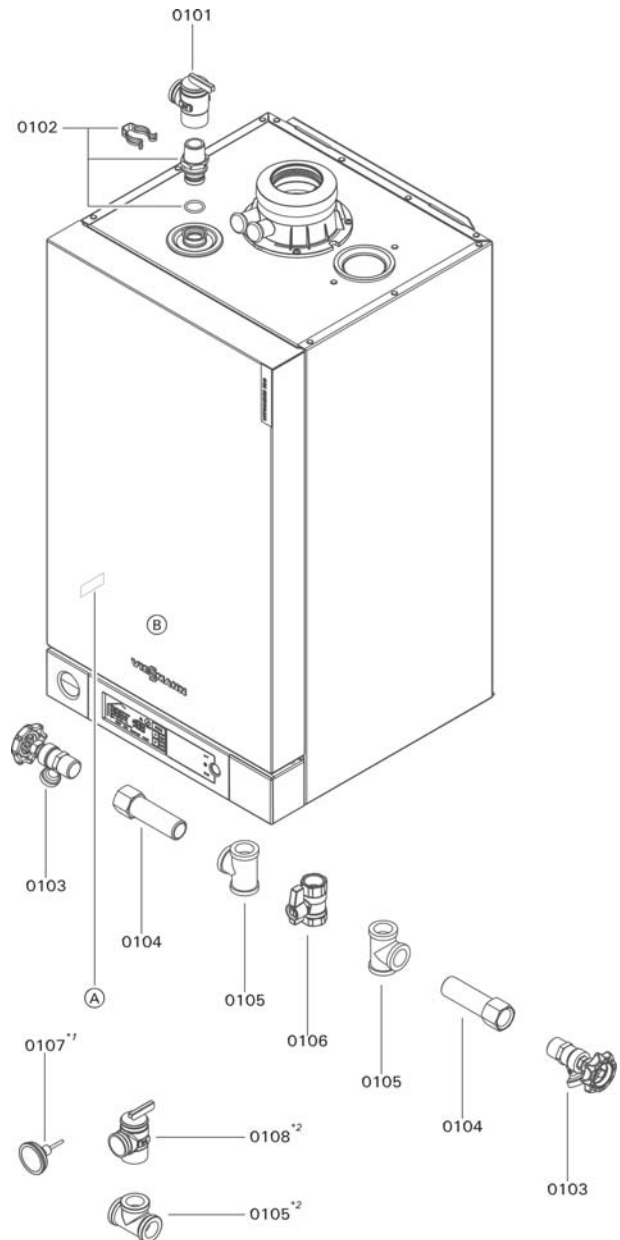

## Maintenance Record

5784 568 - 02

Measurements	Service date: by:	Service date: by:	Service date: by:	Service date: by:	Service date: by:	Service date: by:	Service date: by:	Setpoint value
<b>Static pressure</b>	"w.c.							max. 14 "w.c.
<b>Running pressure (supply pressure)</b>								
<input type="checkbox"/> Natural gas	"w.c.							4-14 "w.c.
<input type="checkbox"/> Liquid Propane gas	"w.c.							10-14 "w.c.
<b>Carbon dioxide content CO<sub>2</sub></b>								
■ at lower end of rated input range (low-fire)	vol.-%							
■ at upper end of rated input range (high-fire)	vol.-%							
<b>Oxygen content O<sub>2</sub></b>								
■ at lower end of rated input range (low-fire)	vol.-%							
■ at upper end of rated input range (high-fire)	vol.-%							
<b>Carbon monoxide content CO</b>								
■ at lower end of rated input range	ppm							Never exceed 50 ppm air-free
■ at upper end of rated input range	ppm							Never exceed 200 ppm air-free

## Lighting and Operating Instructions

### FOR YOUR SAFETY READ BEFORE OPERATING

**W A R N I N G:** If you do not follow these instructions exactly, a fire or explosion may result causing property damage, personal injury or loss of life.

- A. This appliance does not have a pilot. It is equipped with an ignition device which automatically lights the burner. Do not try to light the burner by hand.
- B. **BEFORE OPERATING** smell all around the appliance area for gas. Be sure to smell next to the floor because some gas is heavier than air and will settle on the floor.  
**WHAT TO DO IF YOU SMELL GAS**
  - Do not try to light any appliance.
  - Do not touch any electric switch; do not use any phone in your building.
  - Immediately call your gas supplier from a neighbor's phone. Follow the gas supplier's instructions.
  - If you cannot reach your gas supplier, call the fire department.
- C. Use only your hand to push in or turn the gas control knob. Never use tools. If the knob will not push in or turn by hand, don't try to repair it, call a qualified service technician. Force or attempted repair may result in a fire or explosion.
- D. Do not use this appliance if any part has been under water. Immediately call a qualified service technician to inspect the appliance and to replace any part of the control system and any gas control which has been under water.

### OPERATING INSTRUCTIONS

1. **STOP!** Read the safety information above on this label.
2. Set thermostat or other operating control to lowest setting.
3. Turn off all electric power to the appliance.
4. This appliance is equipped with an ignition device which automatically lights the burner. Do not try to light the burner by hand.
5. Close main gas shut-off valve.
6. Wait five (5) minutes to clear out any gas. Then smell for gas, including near the floor. If you smell gas, **STOP!** Follow "B" in the safety information above on this label. If you don't smell gas, go to the next step.
7. Open main gas shut-off valve.
8. Turn on all electric power to the appliance.
9. Set thermostat or other operating control to desired setting.
10. If the appliance will not operate, follow the instructions "To Turn Off Gas To Appliance" and call your service technician or gas supplier.

Manual gas shutoff

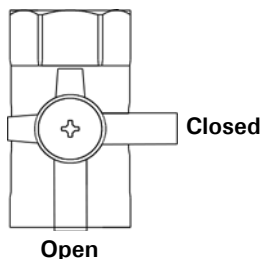

### TO TURN OFF GAS TO APPLIANCE

1. Set thermostat or other operating control to lowest setting.
2. Turn off all electric power to the appliance if service is to be performed.
3. Close main gas shut-off valve.



Scan for  
digital copy  
of this  
document



Viessmann Manufacturing Company Inc.  
750 McMurray Road  
Waterloo, Ontario • N2V 2G5 • Canada  
**TechInfo Line 1-888-484-8643**  
1-800-387-7373 • Fax (519) 885-0887  
[www.viessmann.ca](http://www.viessmann.ca) • [info@viessmann.ca](mailto:info@viessmann.ca)

Viessmann Manufacturing Company (U.S.) Inc.  
45 Access Road  
Warwick, Rhode Island • 02886 • USA  
**TechInfo Line 1-888-484-8643**  
1-800-288-0667 • Fax (401) 732-0590  
[www.viessmann-us.com](http://www.viessmann-us.com) • [info@viessmann-us.com](mailto:info@viessmann-us.com)

