

City of Portland, Maine - Building or Use Permit Application

389 Congress Street, 04101 Tel: (207) 874-8703, Fax: (207) 874-8716

Permit No: 10-0800	Issue Date:	CBL: 129 G020001
-----------------------	-------------	---------------------

Location of Construction: 48 HERSEY ST	Owner Name: GLYNN ROBERT W KW VET &	Owner Address: 48 HERSEY ST	Phone:
Business Name:	Contractor Name: David Dipietro	Contractor Address: 221 Virginia Street Portland	Phone: 2078317914
Lessee/Buyer's Name	Phone:	Permit Type: Additions - Dwellings	Zone: R-3

Past Use: Single Family Home	Proposed Use: Single Family Home - build 12' x 16' deck on rear	Permit Fee: \$40.00	Cost of Work: \$2,000.00	CEO District: 4	55387
Proposed Project Description: build 12 x 16' deck on rear		FIRE DEPT: <input type="checkbox"/> Approved <input checked="" type="checkbox"/> Denied <i>NA</i>	INSPECTION: Use Group: R-3 Type: SB IRC 2003		
		Signature: <i>[Signature]</i>		Signature: <i>[Signature]</i>	

PEDESTRIAN ACTIVITIES DISTRICT (P.A.D.)	
Action: <input type="checkbox"/> Approved <input type="checkbox"/> Approved w/Conditions <input type="checkbox"/> Denied	Signature: _____ Date: _____

Permit Taken By: Idobson	Date Applied For: 07/06/2010	Zoning Approval	
-----------------------------	---------------------------------	------------------------	--

<ol style="list-style-type: none"> This permit application does not preclude the Applicant(s) from meeting applicable State and Federal Rules. Building permits do not include plumbing, septic or electrical work. Building permits are void if work is not started within six (6) months of the date of issuance. False information may invalidate a building permit and stop all work.. 	Special Zone or Reviews <input type="checkbox"/> Shoreland <input checked="" type="checkbox"/> Wetland <i>USING IA-433 for the rear setback</i> <input type="checkbox"/> Flood Zone <input type="checkbox"/> Subdivision <input type="checkbox"/> Site Plan Maj <input type="checkbox"/> Minor <input type="checkbox"/> MM <input type="checkbox"/> Denied Date: <i>7/8/10</i>	Zoning Appeal <input type="checkbox"/> Variance <input type="checkbox"/> Miscellaneous <input type="checkbox"/> Conditional Use <input type="checkbox"/> Interpretation <input type="checkbox"/> Approved <input type="checkbox"/> Denied Date: _____	Historic Preservation <input checked="" type="checkbox"/> Not in District or Landmark <input type="checkbox"/> Does Not Require Review <input type="checkbox"/> Requires Review <input type="checkbox"/> Approved <input type="checkbox"/> Approved w/Conditions <input type="checkbox"/> Denied Date: <i>[Signature]</i>
	<p>PERMIT ISSUED</p> <p>JUL 19 2010</p> <p>City of Portland</p>		

CERTIFICATION

I hereby certify that I am the owner of record of the named property, or that the proposed work is authorized by the owner of record and that I have been authorized by the owner to make this application as his authorized agent and I agree to conform to all applicable laws of this jurisdiction. In addition, if a permit for work described in the application is issued, I certify that the code official's authorized representative shall have the authority to enter all areas covered by such permit at any reasonable hour to enforce the provision of the code(s) applicable to such permit.

SIGNATURE OF APPLICANT ADDRESS DATE PHONE

RESPONSIBLE PERSON IN CHARGE OF WORK, TITLE DATE PHONE

BUILDING PERMIT INSPECTION PROCEDURES

Please call 874-8703 or 874-8693 (ONLY)

or email: buildinginspections@portlandmaine.gov

With the issuance of this permit, the owner, builder or their designee is required to provide adequate notice to the City of Portland Inspection Services for the following inspections. Appointments must be requested 48 to 72 hours in advance of the required inspection. The inspection date will need to be confirmed by this office.

- **Please read the conditions of approval that is attached to this permit!! Contact this office if you have any questions.**
- **Permits expire in 6 months, if the project is not started or ceases for 6 months.**
- **If the inspection requirements are not followed as stated below additional fees may be incurred due to the issuance of a “Stop Work Order” and subsequent release to continue with construction.**

 X **Footing/Building Location Inspection: Prior to pouring concrete or setting precast piers**

 X **Framing inspection required. This can be done at the final inspection if all framing is visible.**

 X **Final inspection required at completion of work.**

The project cannot move to the next phase prior to the required inspection and approval to continue, REGARDLESS OF THE NOTICE OR CIRCUMSTANCES.

IF THE PERMIT REQUIRES A CERTIFICATE OF OCCUPANCY, IT MUST BE PAID FOR AND ISSUED TO THE OWNER OR DESIGNEE BEFORE THE SPACE MAY BE OCCUPIED.

City of Portland, Maine - Building or Use Permit

389 Congress Street, 04101 Tel: (207) 874-8703, Fax: (207) 874-8716

Permit No: 10-0800	Date Applied For: 07/06/2010	CBL: 129 G020001
-----------------------	---------------------------------	---------------------

Location of Construction: 48 HERSEY ST	Owner Name: GLYNN ROBERT W KW VET &	Owner Address: 48 HERSEY ST	Phone:
Business Name:	Contractor Name: David Dipietro	Contractor Address: 221 Virginia Street Portland	Phone (207) 831-7914
Lessee/Buyer's Name	Phone:	Permit Type: Additions - Dwellings	

Proposed Use: Single Family Home - build 12' x 16' deck on rear	Proposed Project Description: build 12 x 16' deck on rear
--	--

Dept: Zoning	Status: Approved with Conditions	Reviewer: Marge Schmuckal	Approval Date: 07/08/2010
Note:			Ok to Issue: ✓
<ol style="list-style-type: none"> 1) Separate permits shall be required for future decks, sheds, pools, and/or garages. 2) This is NOT an approval for an additional dwelling unit. You SHALL NOT add any additional kitchen equipment including, but not limited to items such as stoves, microwaves, refrigerators, or kitchen sinks, etc. Without special approvals. 3) This property shall remain a single family dwelling. Any change of use shall require a separate permit application for review and approval. 4) This permit is being approved on the basis of revised plans submitted. Any deviations shall require a separate approval before starting that work. 			
Dept: Building	Status: Approved with Conditions	Reviewer: Tammy Munson	Approval Date: 07/19/2010
Note:			Ok to Issue: ✓
<ol style="list-style-type: none"> 1) Permit approved based on the plans submitted and reviewed w/owner/contractor, with additional information as agreed on and as noted on plans. 			

Comments:
7/7/2010-mes: the proposal is not meeting the 25' rear setback and is over the 35% lot coverage - I spoke to David P. - He will discuss with Dwight - this is a City loan job.
7/8/2010-mes: I spoke with Dwight - there is a 10'x16' deck on the rear that has never been permitted. Using section 14-433, I can allow a reduced setback to just rebuild the existing deck and not to enlarge it. David D. Needs to come in and revise the plot plan



General Building Permit Application

If you or the property owner owes real estate or personal property taxes or user charges on any property within the City, payment arrangements must be made before permits of any kind are accepted.

Location/Address of Construction: <u>48 HERSEY ST</u>		
Total Square Footage of Proposed Structure/Area <u>280</u>	Square Footage of Lot <u>5538</u>	Number of Stories <u>1</u>
Tax Assessor's Chart, Block & Lot Chart# Block# Lot# <u>129</u> <u>G</u> <u>20</u>	Applicant * <u>must be owner, Lessee or Buyer</u> * Name <u>ROBERT GLYN</u> Address <u>48 HERSEY ST</u> City, State & Zip <u>PORTLAND</u>	Telephone:
Lessee/DBA (If Applicable)	Owner (if different from Applicant) Name Address City, State & Zip	Cost Of Work: \$ <u>2000.00</u> C of O Fee: \$ _____ Total Fee: \$ <u>40</u>
Current legal use (i.e. single family) <u>SINGLE FAMILY</u> Number of Residential Units _____ If vacant, what was the previous use? _____ Proposed Specific use: <u>DECK</u> Is property part of a subdivision? <u>12x14</u> If yes, please name _____ Project description: <u>BUILD THE DECK ON REAR</u>		
Contractor's name: <u>DAVID DIPIETRO</u> Address: <u>221 VIRGINIA ST PORTLAND</u> City, State & Zip: <u>ME 04103</u> Telephone: <u>831 7914</u> Who should we contact when the permit is ready: <u>DAVID</u> Telephone: _____ Mailing address: _____		

Please submit all of the information outlined on the applicable Checklist. Failure to do so will result in the automatic denial of your permit.

In order to be sure the City fully understands the full scope of the project, the Planning and Development Department may request additional information prior to the issuance of a permit. For further information or to download copies of this form and other applications visit the Inspections Division on-line at www.portlandmaine.gov, or stop by the Inspections Division office, room 315 City Hall or call 874-8703.

I hereby certify that I am the Owner of record of the named property, or that the owner of record authorizes the proposed work and that I have been authorized by the owner to make this application as his/her authorized agent. I agree to conform to all applicable laws of this jurisdiction. In addition, if a permit for work described in this application is issued, I certify that the Code Official's authorized representative shall have the authority to enter all areas covered by this permit at any reasonable hour to enforce the provisions of the codes applicable to this permit.

Signature: [Signature] Date: 7-6-10

This is not a permit; you may not commence ANY work until the permit is issued

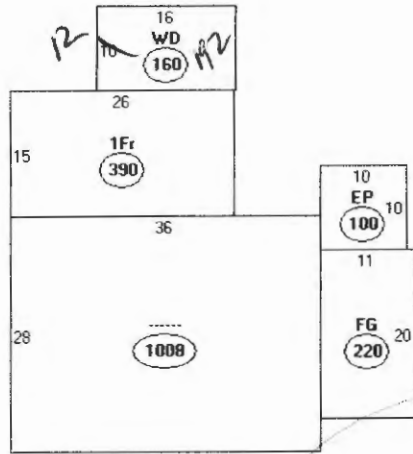

Descriptor/Area	Area
A: 1008 sqft	1008
B: 1Fr 390 sqft	390
C: WD 160 sqft	160
D: EP 100 sqft	100
E: FG 220 sqft	220
	<hr/>
	1878
	1878
	1910

5538# x 35% = 1938.3

OK
OK

~~1878~~
1910

using 14-433 for The reduced
rear setback AT About 22'
instead of 25' required

David D. DiPietro
General Contractor

Top Quality Workmanship • Free Estimates • Commercial & Residential

221 Virginia Street • Portland, Maine • (207) 797-9531

48 HERSEY ST

R-3
Front - NA
REAR: 22' Allowance
under 443'
Side - 8' min -
12' 5' min

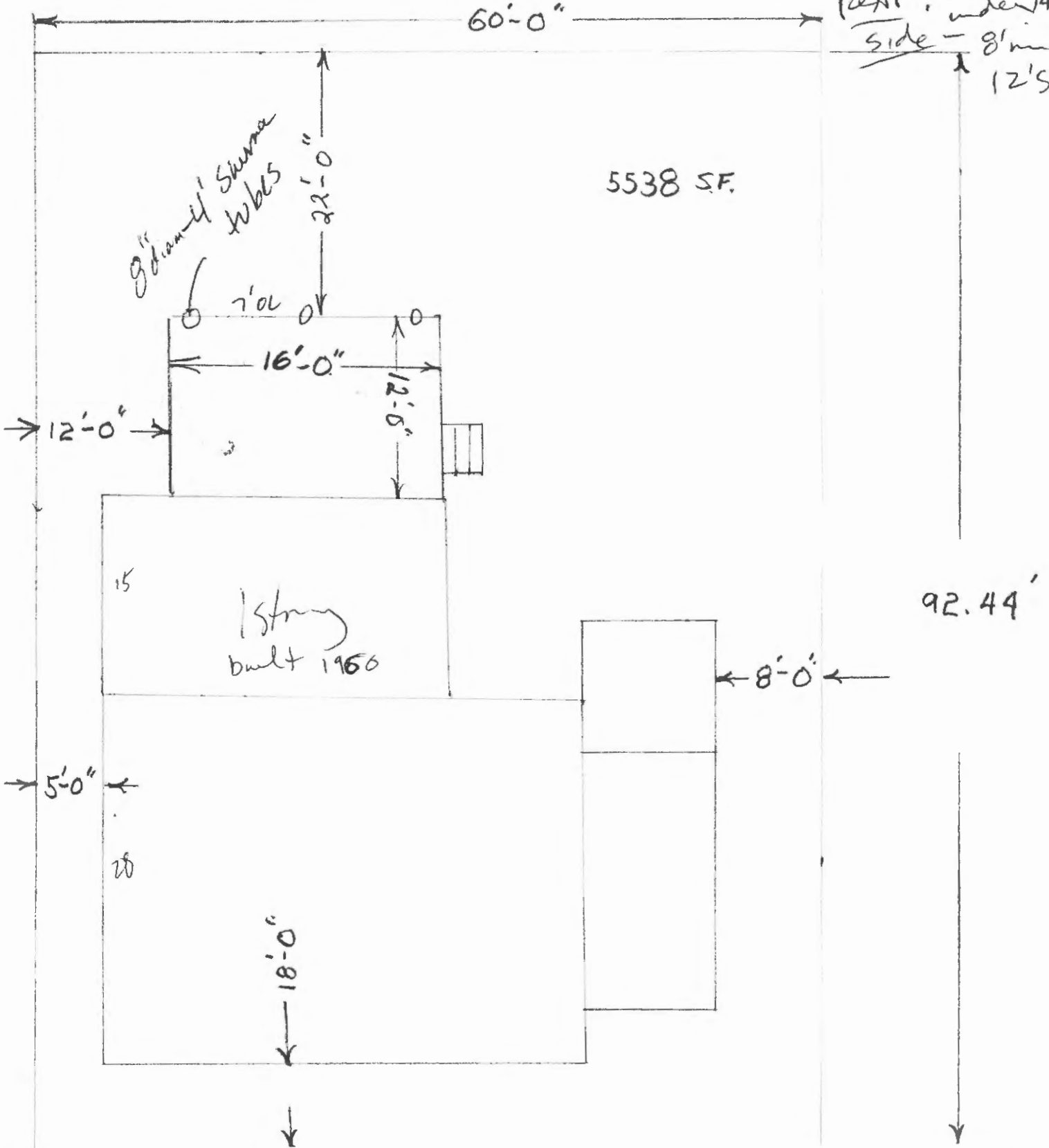

92.44
60.00
32.44

17.
28
16
60

STREET

HERSEY

35
40
42
44
46
48
50
52
55

55
55
55
55
55
55
55
55
55

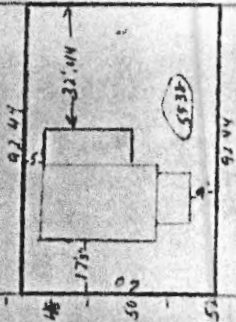

36" high
Guard w/ ballusters
w/ 2" spacing

48 HERSEY ST

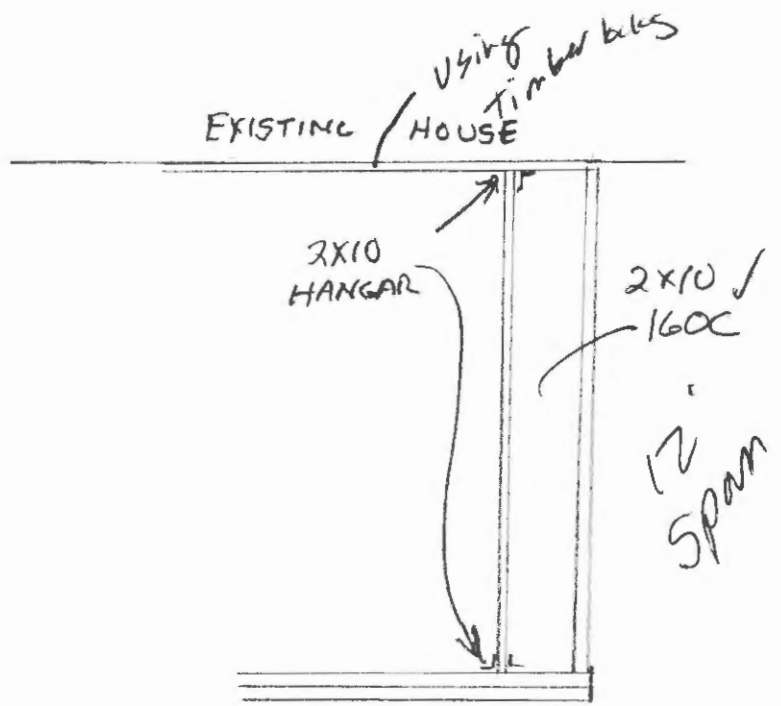
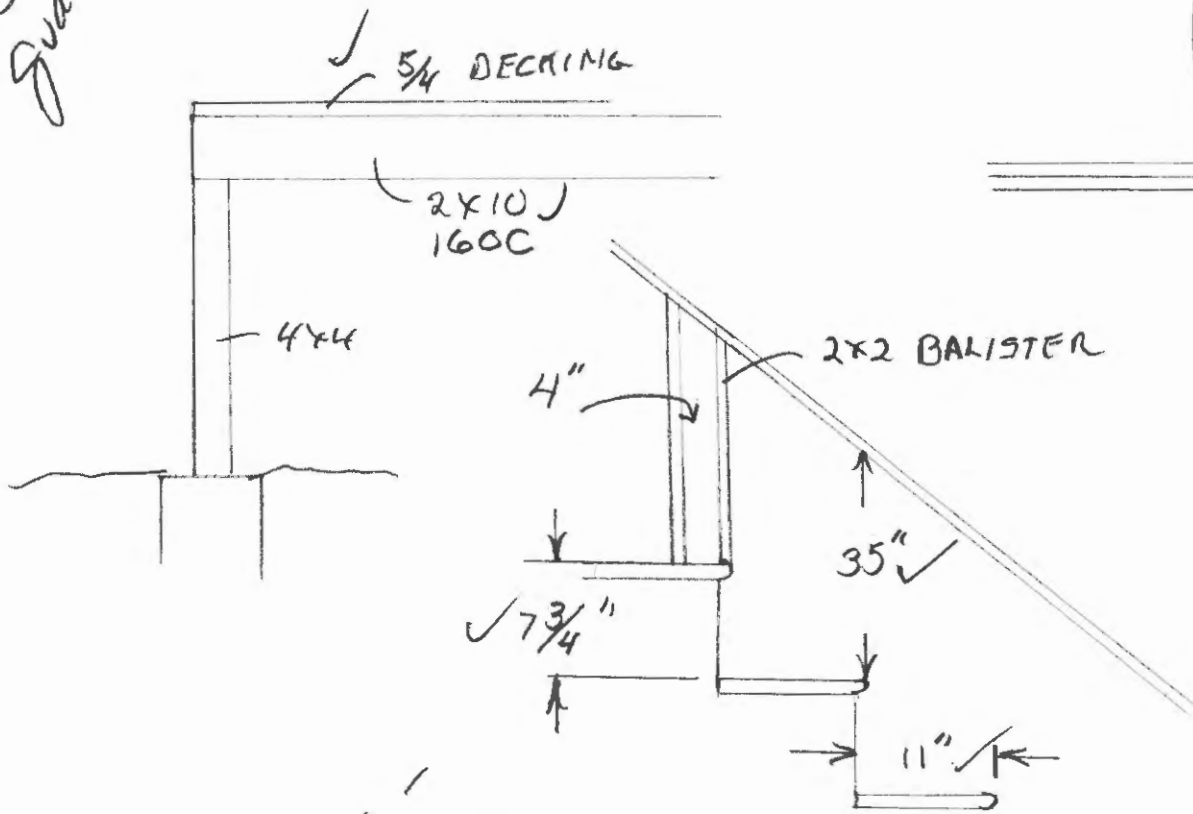

2- 2x10's -
7' max span
Need 3 tubes
Set 1" from
each corner +
1" in center -
Called Dave D.



CITY OF PORTLAND, MAINE

Department of Building Inspections

Original Receipt

_____ 7.6. 20 10 _____

Received from Land Tech Dev.

Location of Work 48 Hershey

Cost of Construction \$ _____ Building Fee: _____

Permit Fee \$ _____ Site Fee: _____

Certificate of Occupancy Fee: _____

Total: 40

Building (IL) Plumbing (IS) Electrical (I2) Site Plan (U2)

Other _____

CBL: 129 6-20

Check #: 5046 Total Collected \$ 40

**No work is to be started until permit issued.
Please keep original receipt for your records.**

Taken by: [Signature]

WHITE - Applicant's Copy
YELLOW - Office Copy
PINK - Permit Copy