

**1 Construction Plan**  
A-1 SCALE: 1/4" = 1'-0"

**LEGEND/NOTES:**  
 Existing walls/partitions  
 New wd. walls/partitions

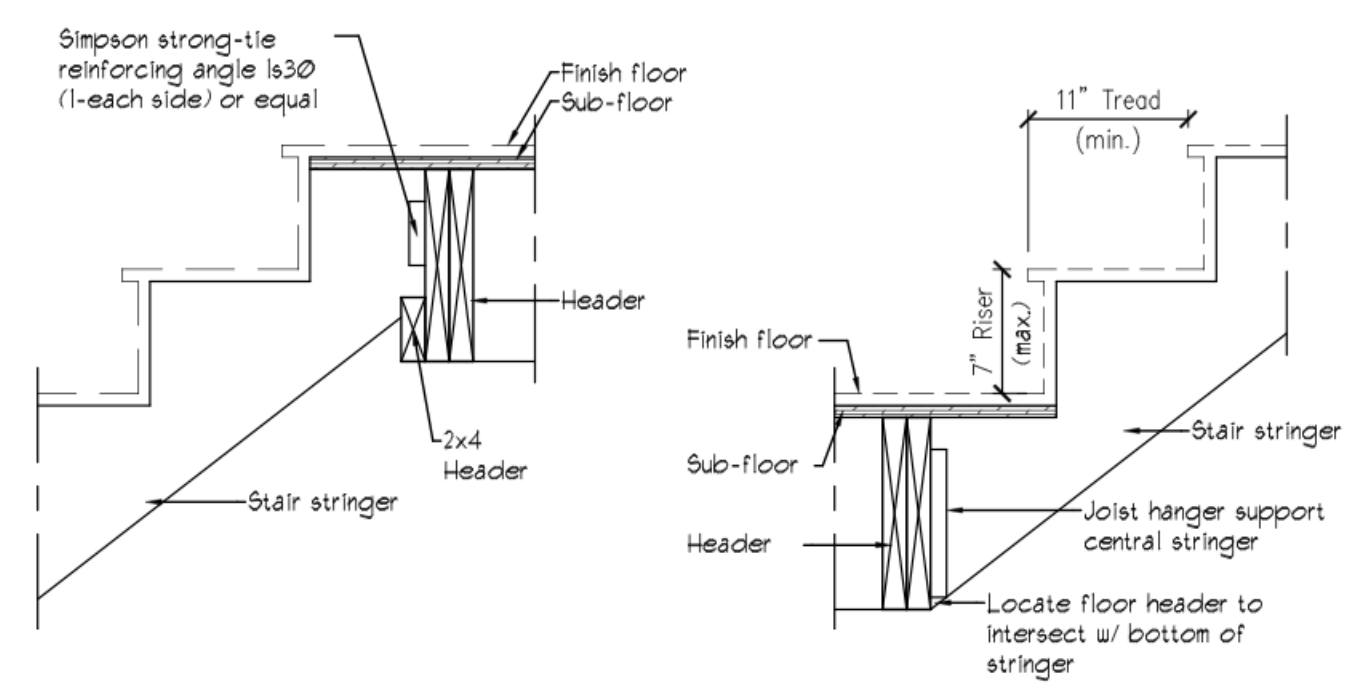

**5 Stair Section Detail**  
A-1 SCALE: 1" = 1'-0"

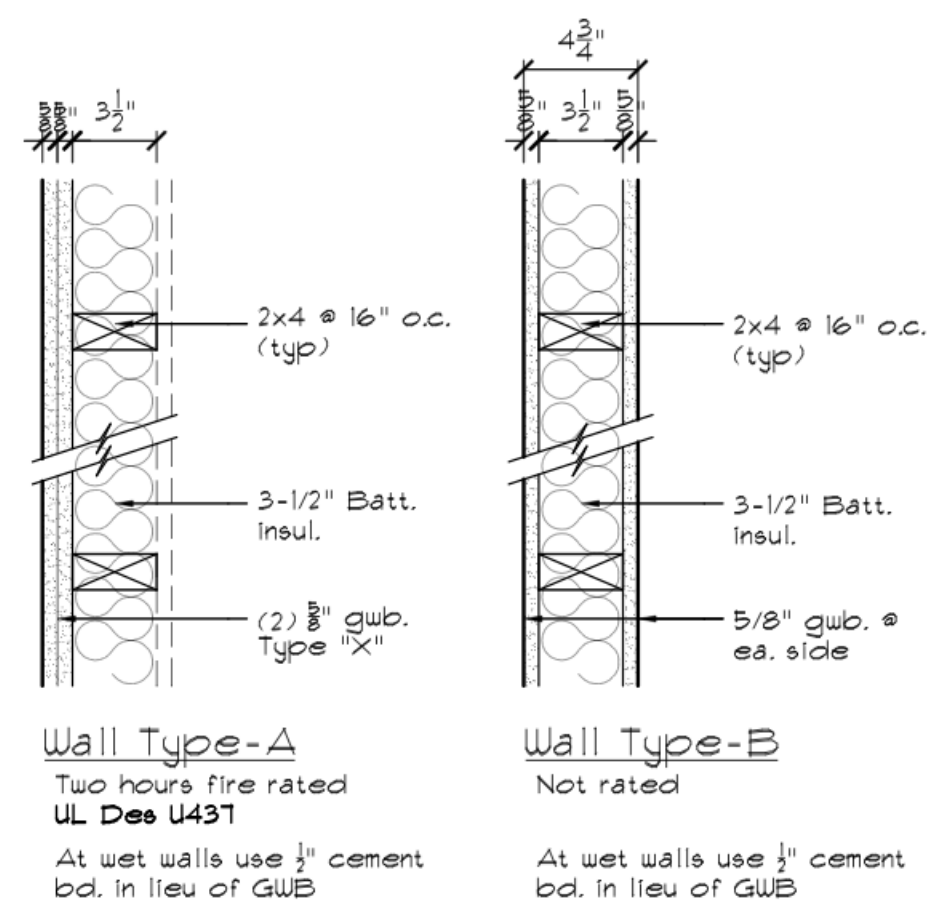

**4 Wall Types**  
A-1 SCALE: 1-1/2" = 1'-0"

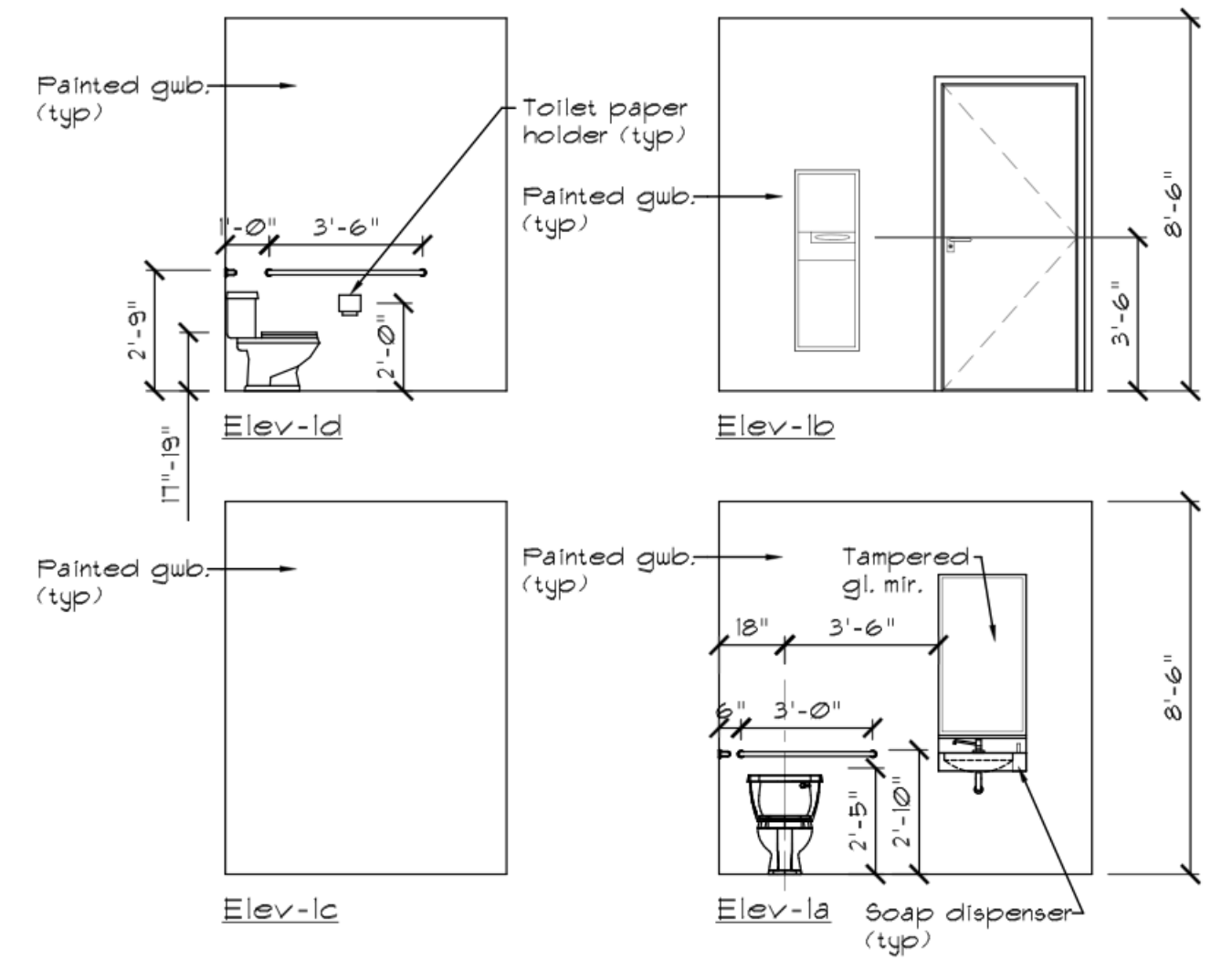

**3 Interior Elevations**  
A-1 SCALE: 1/4" = 1'-0"

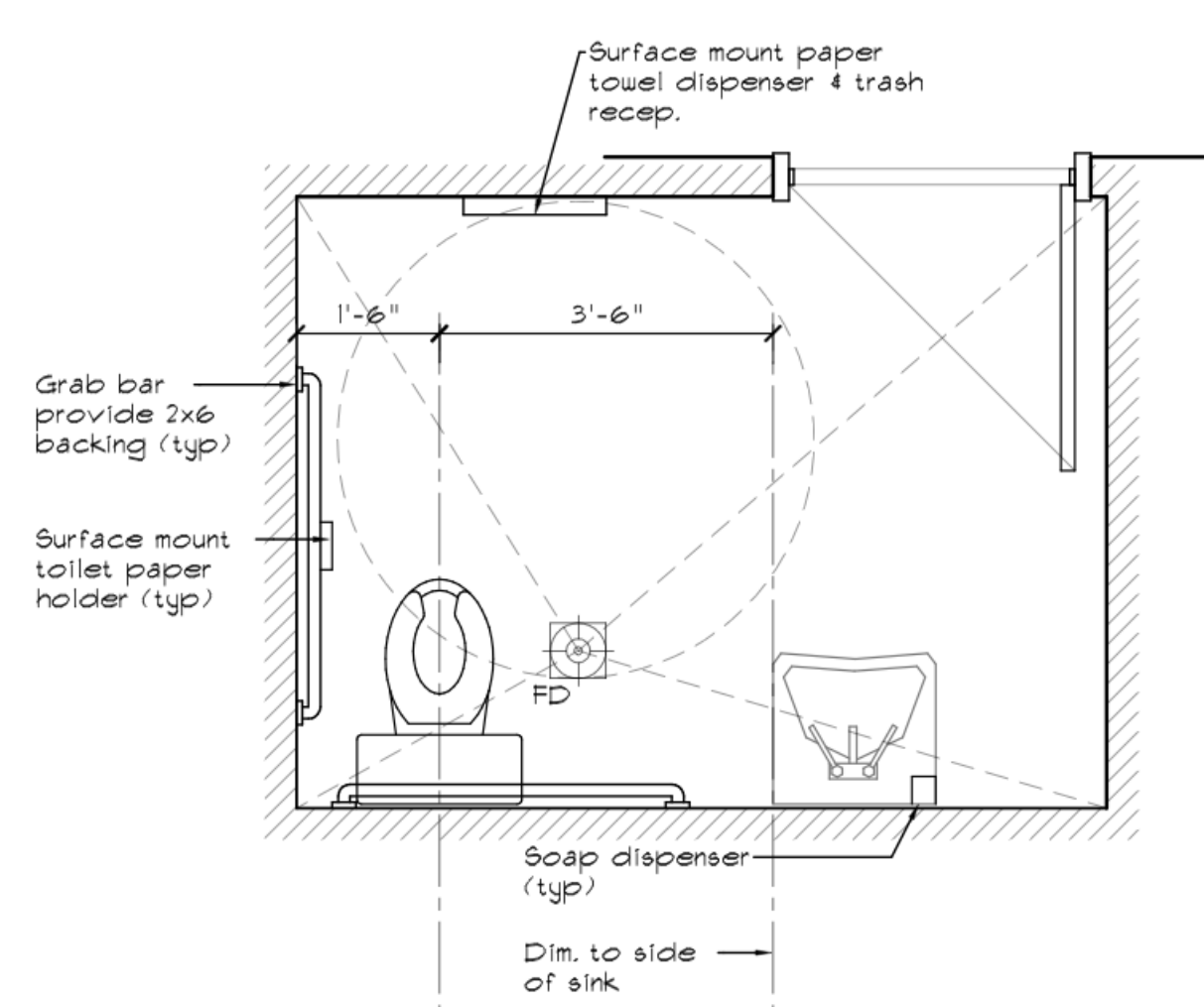

**2 Enlarged Toilet Plan**  
A-1 SCALE: 1/2" = 1'-0"

architecture of  
**vina**  
design inc  
engineering

423 Park Ave, Worcester, MA 01610  
Tel: 774.239.3657 Fax: 508.753.6542  
Email: vinadesign2008@gmail.com

PROJECT  
Renovation

**Millenia Nails & Spa-II**  
669 Forest Avenue  
Portland, ME

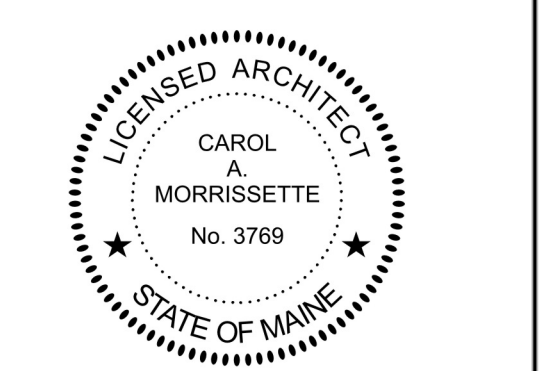

RESIDENTIAL DESIGN STUDIO, LLC  
Carol A. Morrissette  
90 Woodford Street  
Portland, Maine 04103  
T 207.699.4184 C 207.671.7965



**Proposed Floor Plan, Details, and Notes**

Revisions	Date
Revision-1	
Revision-2	

Scale	AS NOTED
Drawn / Check by	JL/BAN
Date	11/18/15
Job No.	XX

A-1

PERMIT SET