

City of Portland, Maine - Building or Use Permit Application

389 Congress Street, 04101 Tel: (207) 874 8703, Fax: (207) 874-8716

Permit No: 10-1384	Issue Date:	CBL: 129 A005001
-----------------------	-------------	---------------------

Location of Construction: 688 FOREST AVE	Owner Name: MANTGIARIS PETER & XENIA J	Owner Address: 1706 WILLOW CT	Phone:
Business Name:	Contractor Name: Avery Services, Inc.	Contractor Address: 7 Thomas Drive Westbrook	Phone: 2077728687
Lessee/Buyer's Name	Phone:	Permit Type: HVAC	Zone: B-2b

Part Use: Commercial " Valley Chinese Cuisine"	Proposed Use: Commercial " Valley Chinese Cuisine" - install a Package unit on roof top (replacement)	Permit Fee:	Cost of Work: \$0.00	CEO District: 4
---	--	-------------	-------------------------	--------------------

Proposed Project Description:
install a Package unit on roof top (replacement)

FIRE DEPT: Approved Denied
N/A
 Signature: _____

INSPECTION:
 Use Group: *U* Type: *HVAC*
State Gas Reg
 Signature: _____
 Date: _____

PEDESTRIAN ACTIVITIES DISTRICT (P.A.D.)
 Action Approved Approved w/Conditions Denied
 Signature: _____ Date: _____

Permit Taken By: idobson	Date Applied For: 11/04/2010	Zoning Approval	
-----------------------------	---------------------------------	------------------------	--

<p>1. This permit application does not preclude the Applicant(s) from meeting applicable State and Federal Rules.</p> <p>2. Building permits do not include plumbing, septic or electrical work.</p> <p>3. Building permits are void if work is not started within six (6) months of the date of issuance. False information may invalidate a building permit and stop all work.</p> <p style="font-size: 24pt; text-align: center;">PERMIT ISSUED</p> <p style="text-align: center;">NOV - 8 2010</p>	<p>Special Zone or Reviews</p> <input type="checkbox"/> Shoreland <input type="checkbox"/> Wetland <input type="checkbox"/> Flood Zone <input type="checkbox"/> Subdivision <input type="checkbox"/> Site Plan Maj <input type="checkbox"/> Minor <input type="checkbox"/> MM <input type="checkbox"/> OK Date: 11/3/10 <i>AKA</i>	<p>Zoning Appeal</p> <input type="checkbox"/> Variance <input type="checkbox"/> Miscellaneous <input type="checkbox"/> Conditional Use <input type="checkbox"/> Interpretation <input type="checkbox"/> Approved <input type="checkbox"/> Denied Date: _____	<p>Historic Preservation</p> <input checked="" type="checkbox"/> Not in District or Landmark <input type="checkbox"/> Does Not Require Review <input type="checkbox"/> Requires Review <input type="checkbox"/> Approved <input type="checkbox"/> Approved w/Conditions <input type="checkbox"/> Denied Date: <i>AKA</i>
---	--	---	---

City of Portland

CERTIFICATION

I hereby certify that I am the owner of record of the named property, or that the proposed work is authorized by the owner of record and that I have been authorized by the owner to make this application as his authorized agent and I agree to conform to all applicable laws of this jurisdiction. In addition, if a permit for work described in the application is issued, I certify that the code official's authorized representative shall have the authority to enter all areas covered by such permit at any reasonable hour to enforce the provision of the code(s) applicable to such permit.

City of Portland, Maine - Building or Use Permit

189 Congress Street, D4101 Tel: (207) 874-8703, Fax: (207) 874-8716

Permit No: 10-1384	Date Applied For: 11/04/2010	CRL: 129 A005001
------------------------------	--	----------------------------

Location of Construction: 588 FOREST AVE	Owner Name: MANTOCHARIS PETER & XENIA J	Owner Address: 1706 WILLOW CT	Phone:
Business Name:	Contractor Name: Avery Services, Inc.	Contractor Address: 7 Thomas Drive Westbrook	Phone: (207) 772-8687
Lessee/Buyer's Name	Phone:	Permit Type: HVAC	

Proposed Use: Commercial " Valley Chinese Cuisine" - install a Package unit on roof top (replacement)	Proposed Project Description: install a Package unit on roof top (replacement)
---	--

Dept: Zoning	Status: Approved	Reviewer: Ann Machado	Approval Date: 11/04/2010
Note:			OK to Issue: ✓
Dept: Building	Status: Approved with Conditions	Reviewer: Tammy Munson	Approval Date: 11/08/2010
Note:			OK to Issue: ✓
1) The installation must comply with the State of Maine Gas Regulations.			

PERMIT ISSUED

NOV - 8 2010

City of Portland



CITY OF PORTLAND, MAINE
Department of Building Inspections

Original Receipt

11. 4. 20 10

Received from

Agency Services.

Location of Work

688 Forest Hill

Cost of Construction

\$ 42,076

Building Fee:

Permit Fee

\$

Site Fee:

Certificate of Occupancy Fee:

Total: 100

Building (11)

Plumbing (15)

Electrical (22)

Gas Permit (21)

Other

for: 139 A-S Valley Chinese Cuisine

Check #:

035668

Total Collected \$ 100

No work is to be started until permit issued.
Please keep original receipt for your records.

Taken by:

[Signature]

WHITE - Applicant's Copy

YELLOW - Office Copy

PINK - Permit Copy



FILL IN AND SIGN WITH INK

APPLICATION FOR PERMIT HEATING OR POWER EQUIPMENT

PERMIT ISSUED
NOV - 8 2008

City of Portland

To the INSPECTOR OF BUILDINGS, PORTLAND, ME.

The undersigned hereby applies for a permit to install the following heating, cooking or power equipment in accordance with the Laws of Maine, the Building Code of the City of Portland, and the following specifications:

Location / CBL 688 Forest Ave Use of Building Resident Date 11-4-08

Name and address of owner of appliance Xenia Mantoparis

Installer's name and address Avery Services Inc.
7 Thomas Dr Westbrook 04092 Telephone 772-8687

Location of appliance:

- Basement
- Attic
- Floor
- Roof

Type of Fuel:

- Gas
- Oil
- Solid

Appliance Name: Package Unit

U.L. Approved Yes No

Will appliance be installed in accordance with the manufacturer's installation instructions? Yes No

IF NO Explain: _____

The Type of License of Installer:

- Master Plumber # _____
- Solid Fuel # _____
- Oil # _____
- Gas # PA# 1439
- Other _____

Type of Chimney:

- Masonry Lined
Factory built _____
- Metal
Factory Built U.L. Listing # _____
- Direct Vent
Type _____ U.L.# _____

Type of Fuel Tank

- Oil
- Gas

Size of Tank NAT

Number of Tanks _____

Distance from Tank to Center of Flue _____ feet.

Cost of Work: \$ 3076.-

Permit Fee: \$ 100

Approved

Approved with Conditions

See attached letter or requirement

Fire: _____

File: _____

Bldg.: _____

Inspector's Signature

Date Approved

Signature of Installer

Michael Searles V.P.

White - Inspection

Yellow - File

Pink - Applicant's

Gold - Assessor's Copy



FILL IN AND SIGN WITH INK

APPLICATION FOR PERMIT HEATING OR POWER EQUIPMENT

PERMIT ISSUED

NOV - 8 2010

To the INSPECTOR OF BUILDINGS, PORTLAND, ME.

City of Portland

The undersigned hereby applies for a permit to install the following heating, cooking or power equipment in accordance with the Laws of Maine, the Building Code of the City of Portland, and the following specifications:

Location / CBL 628 Forest Ave Use of Building Resident Date 11-4-09

Name and address of owner of appliance Xenia Mantziaris

Installer's name and address Avery Services Inc.
7 THOMAS DR WESTBROOK 04092 Telephone 772-868711

Location of appliance:

- Basement
- Floor
- Attic
- Roof

Type of Chimney:

- Masonry Lined
Factory built _____
- Metal
Factory Built U.L. Listing # _____
- Direct Vent
Type _____ U.L. # _____

Type of Fuel:

- Gas
- Oil
- Solid

Appliance Name: Package Unit

U.L. Approved Yes No

Will appliance be installed in accordance with the manufacturer's installation instructions? Yes No

If NO Explain: _____

The Type of License of Installer:

- Master Plumber # _____
- Solid Fuel # _____
- Oil # _____
- Gas # PA1 1439
- Other _____

Type of Fuel Tank

- Oil
- Gas

Size of Tank Nat

Number of Tanks _____

Distance from Tank to Center of Flame _____ feet

Cost of Work: \$ 7076.-

Permit Fee: \$ 100

Approved

Approved with Conditions

See attached letter or requirement

Fire: _____

Ele.: _____

Bldg.: _____

Inspector's Signature

Date Approved

Signature of Installer

Michael Sankey V.P.

White - Inspection

Yellow - File

Pink - Applicant's

Gold - Assessor's Copy



22 Oakmont Drive
Old Orchard Beach, ME 04064-4121
Phone: (207) 934-8038
Fax: (207) 934-8039

MEMORANDUM

Date: November 4, 2010
Project: 688 Forest Avenue, Portland, ME
To: Anna Zafirou
From: David Tetregault
Subject: Proposed Rooftop Unit

I conducted a visual inspection of roof framing at the subject property on Nov. 2, 2010. The purpose of the visual inspection was to determine whether the proposed rooftop unit will have an adverse structural effect on the existing building. The proposed unit will replace an existing unit at the same location. The unit is located at the flat roof area over the kitchen at the current Valley Chinese Restaurant. The proposed unit is a Carrier 48TCEA06A. The total weight including economizer and curb is 720 pounds.

The framing that will support the rooftop unit consists of 2x10 rafters spaced at 16" and spanning 8'. The flat roof area is between a 6'-8" tall parapet wall to north and a gable-shaped roof to the south. The area is subject to drifting and unbalanced snow loading based on the 2006 International Building Code. I reviewed the load-carrying capacity of the roof framing and found that it can support the weight of the proposed unit, the roof dead load (self weight) and the code required snow loading.

Please let me know if I can be of further assistance.



SIGNATURE: David J. Tetregault

PROPOSAL

831

To Mike

AVERY SERVICES, INC.
 7 Thomas Drive
 WESTBROOK, MAINE 04092
 (207) 772-8887

FAX (207) 874-0933

TO: Xenia
 Xenia Mantzaris
 1706 Willow Court
 Woodstock GA 30188

PHONE 770-924-4646	DATE 10/28/2010
JOB NAME/LOCATION Valley Chinese package unit	
JOB NUMBER MSD #003423	JOB PHONE

We hereby submit specifications and estimates for:

Avery Services, Inc. is pleased to submit a quote to perform the following work:

- Provide and install a Carrier 48TCEA06A, 5-ton package unit.
- Provide and install an adapter curb.
- Provide and install an economizer for "free cooling" and fresh air.
- Tie back into existing power wiring, control and gas piping.

OPTION 1) Eliminate the economizer for "free cooling" and fresh air. DEDUCT \$725.00 _____ initials.
 ** This will eliminate the fresh air requirement under building codes.

EXCLUSIONS: Structural, soffiting, carpentry, cost of structural engineer's report and adequacy of existing systems.

We Propose hereby to furnish material and labor - complete in accordance with the above specifications, for the sum of
Seven Thousand Seventy Six and 00/100 Dollars dollars (\$) **7,076.00**

Payment to be made as follows:
\$2,358.00 upon acceptance - Progress billing/net 10 days - All balances due upon substantial completion.
 If payment is not made as outlined above, a service charge of 2% per month on the overdue balance plus all reasonable costs of collection, including attorney's fees will be paid.

All material is guaranteed to be as specified. All work is to be completed in a professional manner according to standard practices. Any alteration or deviation from above specifications involving extra costs will be assessed only upon written orders, and will become an extra charge over and above the estimate. All agreements contingent upon strikes, accidents or delays beyond our control. Ours is to carry fire, theft, and other necessary insurances. Our workers are fully covered by Worker's Compensation insurance.

Acceptance of Proposal - The above prices, specifications and conditions are satisfactory and are hereby accepted. You are authorized to do the work as specified. Payment will be made as outlined above.

Date of acceptance: 11/3/10

Authorized Signature

Xenia Mantzaris

 NOTE: This proposal may be withdrawn by us if not accepted within **30** days.

Signature

Xenia Mantzaris
Xenia Mantzaris (POB)

Signature

CURBS & WEIGHTS DIMENSIONS - CHASSIS 1

NOTES

1. DIMENSIONS ARE IN INCHES. DIMENSIONS IN PARENTHESES ARE IN MILLIMETERS.
2. CENTER OF GRAVITY
3. DIRECTION OF AIR FLOW

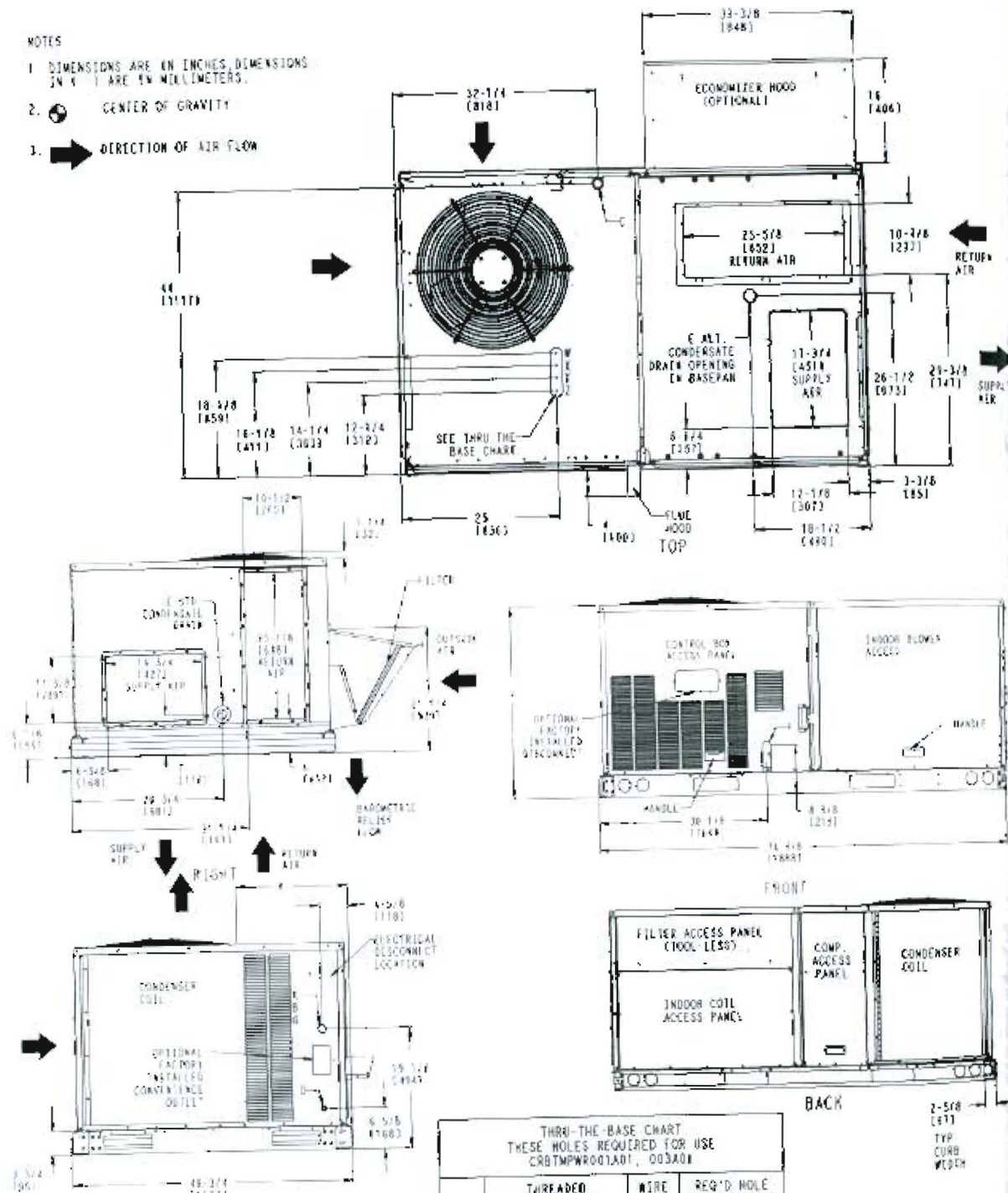

LETTER	DESCRIPTION
A	1 3/8" DIA (33) FIELD POWER SUPPLY HOLE
B	2" (50) DIA POWER SUPPLY KNOCKOUT
C	1 3/4" DIA (51) GAUGE ACCESS PLUG
D	7/8" DIA (22) FIELD CONTROL WIRING HOLE
E	3/4" x 1/4" NPT CONDENSATE DRAIN
F	1/2" x 1/4" NPT GAS CONNECTION
G	2 1/2" DIA (64) POWER SUPPLY KNOCK-OUT

Fig. 1 - Dimensions 48TC 04-07

48TC

48TC

CURBS & WEIGHTS DIMENSIONS - CHASSIS 1 (cont.)

UNIT	STD. UNIT WEIGHT		CORNER WEIGHT (A)		CORNER WEIGHT (B)		CORNER WEIGHT (C)		CORNER WEIGHT (D)		C.G.		HEIGHT
	LBS.	KG.	LBS.	KG.	LBS.	KG.	LBS.	KG.	LBS.	KG.	X	Y	
48TC-A04	483	219	111	50	125	57	131	59	116	53	39 (991)	23 (584)	16 3/8 (416)
48TC-A05	537	244	124	56	139	63	145	66	129	59	39 (991)	23 (584)	17 (432)
48TC-A06	569	258	131	59	147	67	154	70	131	62	39 (991)	23 (584)	17 1/4 (438)
48TC-A07	652	296	150	68	169	76	176	80	154	71	39 (991)	23 (584)	20 1/8 (511)

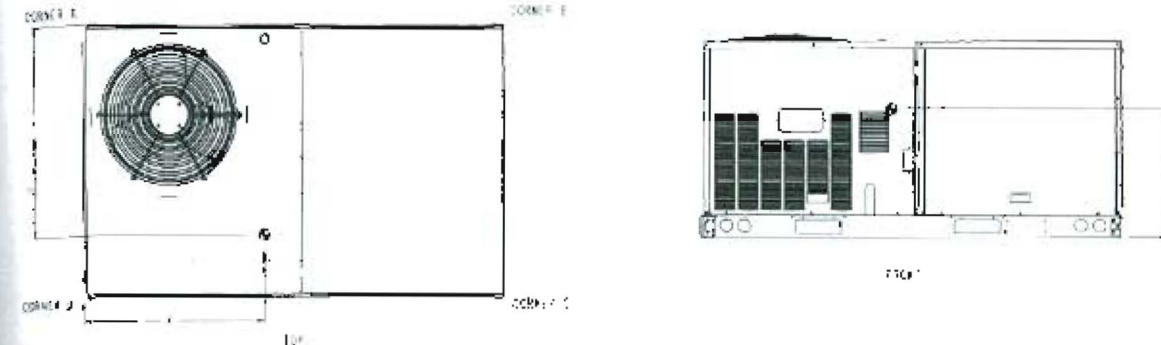

Fig. 2 - Dimensions 48TC 04-07

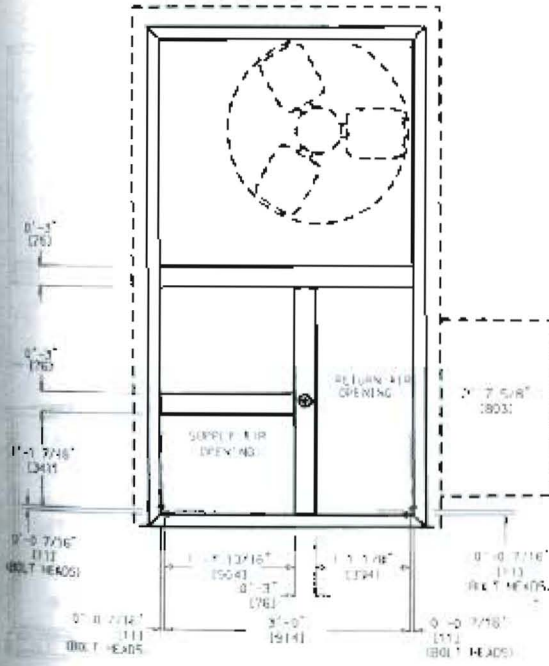

Fig. 3 - Curb Dimensions

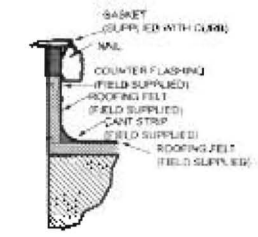

Fig. 4 - Curb Installation Detail (Typical)

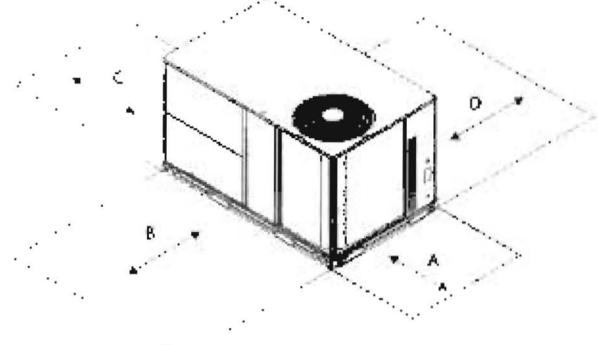

Fig. 5 - Service Clearance

LOC	DIMENSION	CONDITION
A	48" (1219 mm)	Unit disconnect is mounted on panel
	18" (457 mm)	No disconnect, convenience outlet option
	18" (457 mm)	Recommended service clearance
	12" (305 mm)	Minimum clearance
B	42" (1067 mm)	Surface behind servicer is grounded (e.g., metal, masonry wall)
	36" (914 mm)	Surface behind servicer is electrically non-conductive (e.g., wood, fiberglass) Check for sources of flue products within 10-ft of unit fresh air intake hood
C	36" (914 mm)	Side condensate drain is used
	18" (457 mm)	Minimum clearance
D	48" (1219 mm)	No flue discharge accessory installed, surface is combustible material
	42" (1067 mm)	Surface behind servicer is grounded (e.g., metal, masonry wall, another unit)
	38" (914 mm)	Surface behind servicer is electrically non-conductive (e.g., wood, fiberglass)
	Special	Check for adjacent units or building fresh air intakes within 10-ft of this unit's flue outlet