

1 TOILET ROOM PLANS
1/2" = 1'-0"

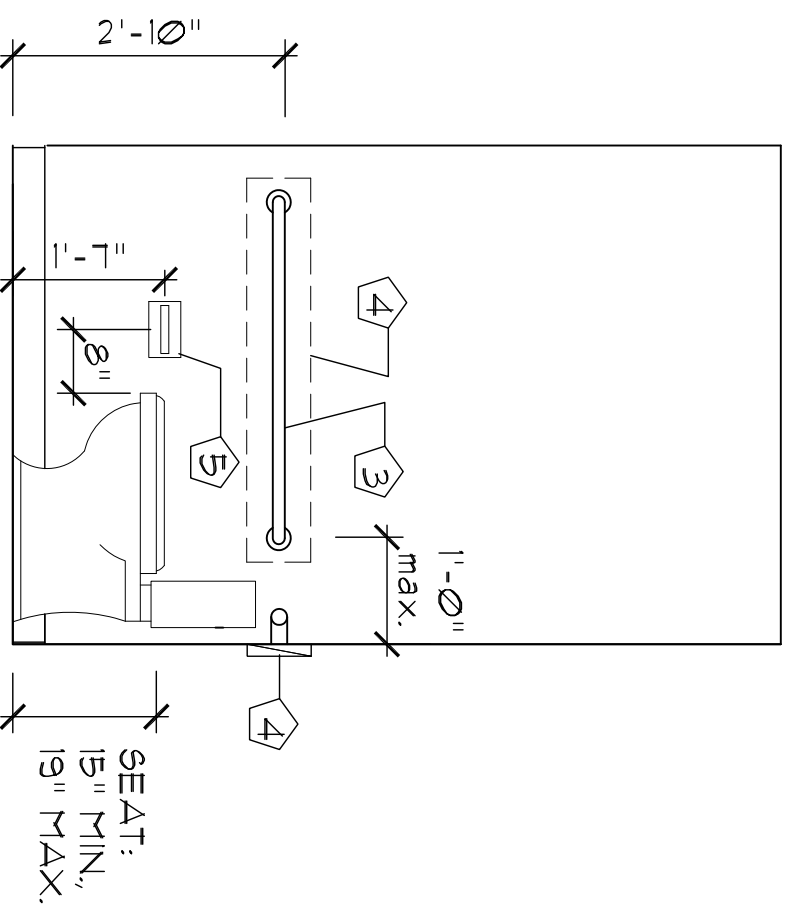

A TLT 104 - ELEVATION
SCALE: 1/2" = 1'-0"

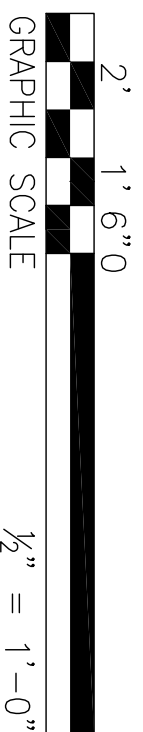
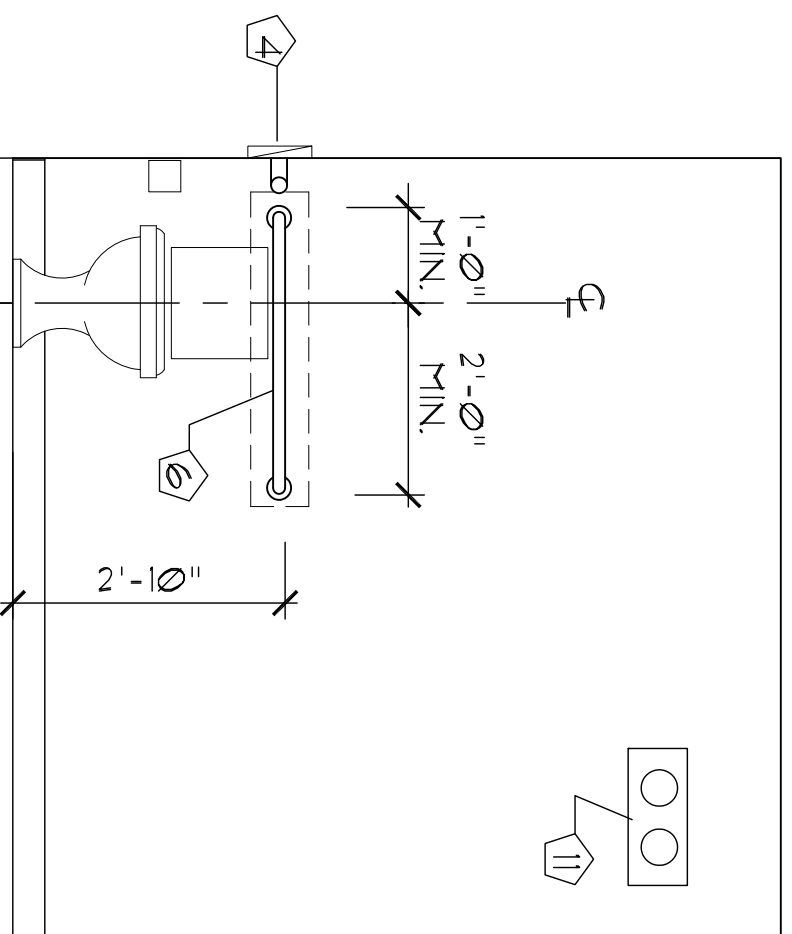

B TLT 104 - ELEVATION
SCALE: 1/2" = 1'-0"



C TLT 104 - ELEVATION
SCALE: 1/2" = 1'-0"

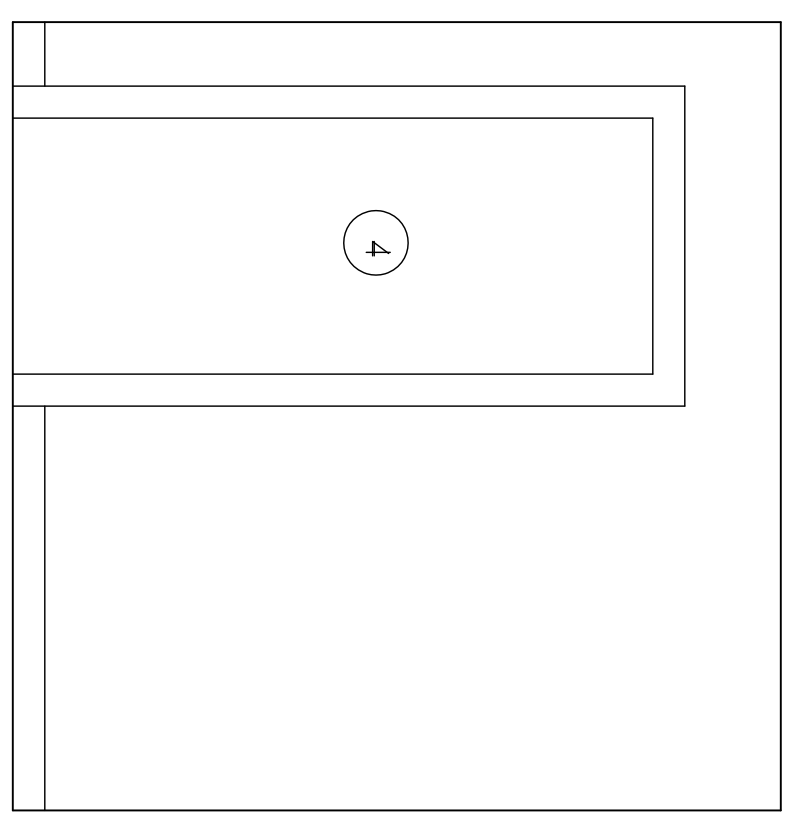

C TLT 104 - ELEVATION
SCALE: 1/2" = 1'-0"

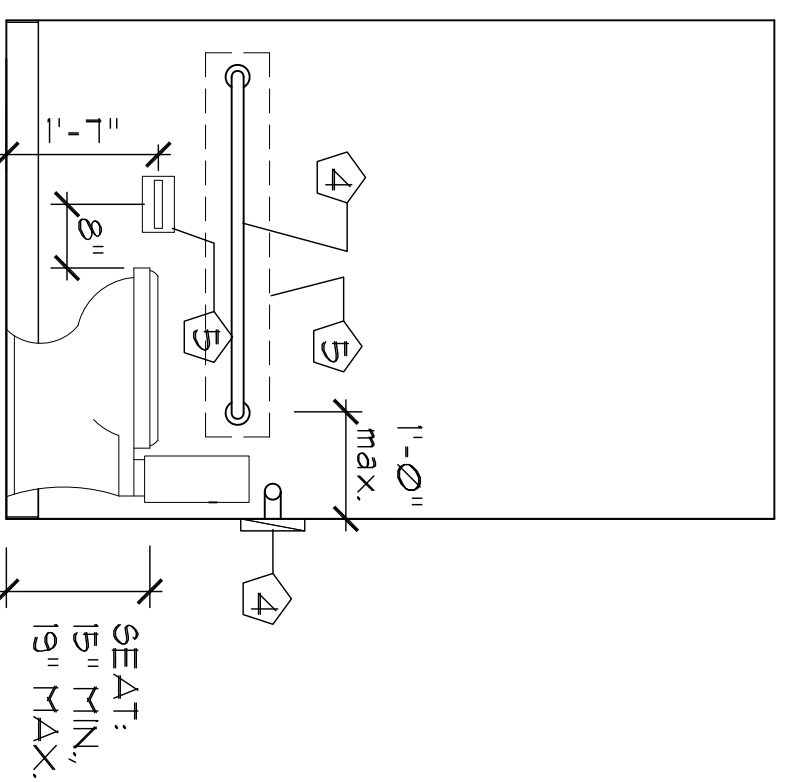

A TLT 105 - ELEVATION
SCALE: 1/2" = 1'-0"

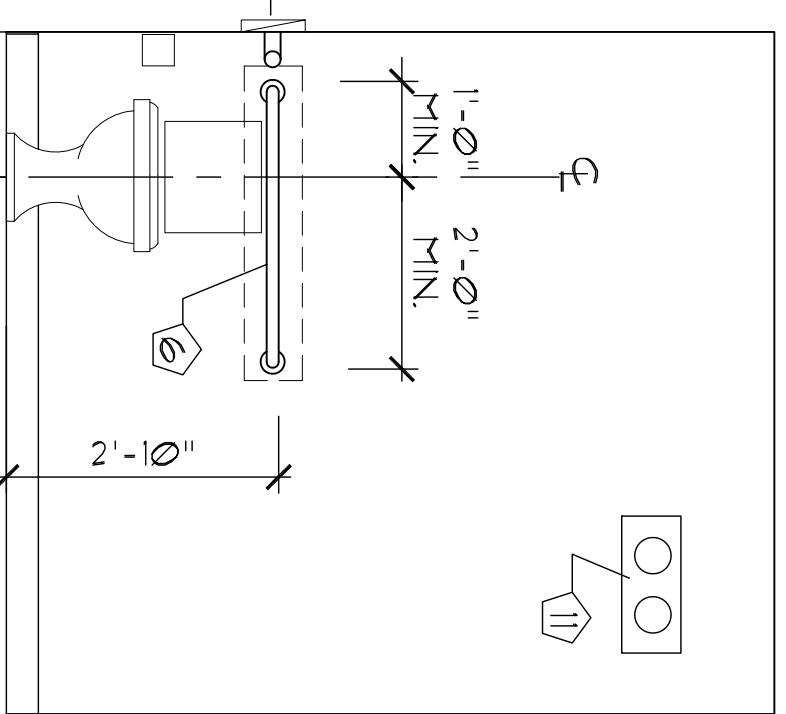

B TLT 105 - ELEVATION
SCALE: 1/2" = 1'-0"



C TLT 105 - ELEVATION
SCALE: 1/2" = 1'-0"

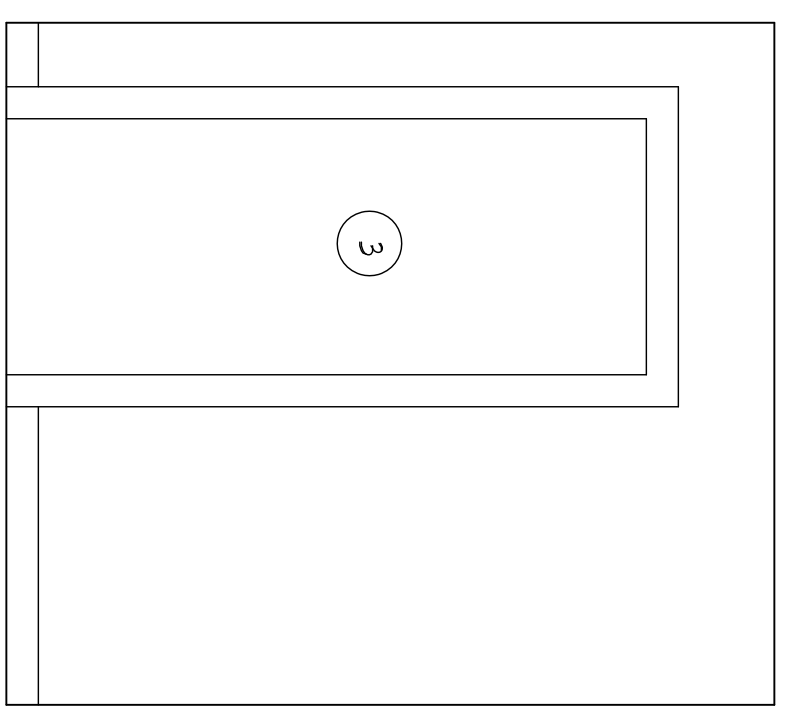

C TLT 105 - ELEVATION
SCALE: 1/2" = 1'-0"

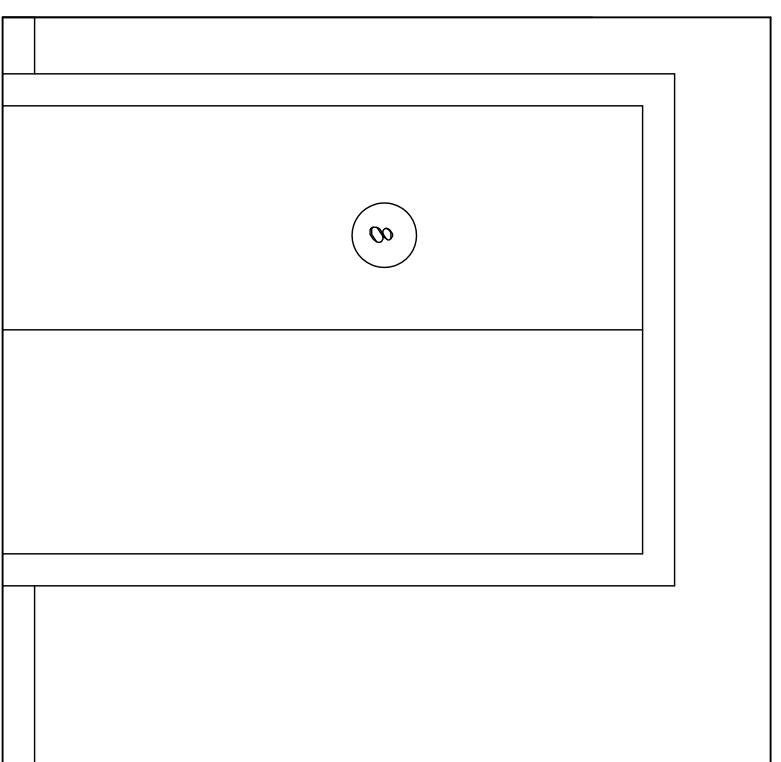

A LAV 109 - ELEVATION
SCALE: 1/2" = 1'-0"

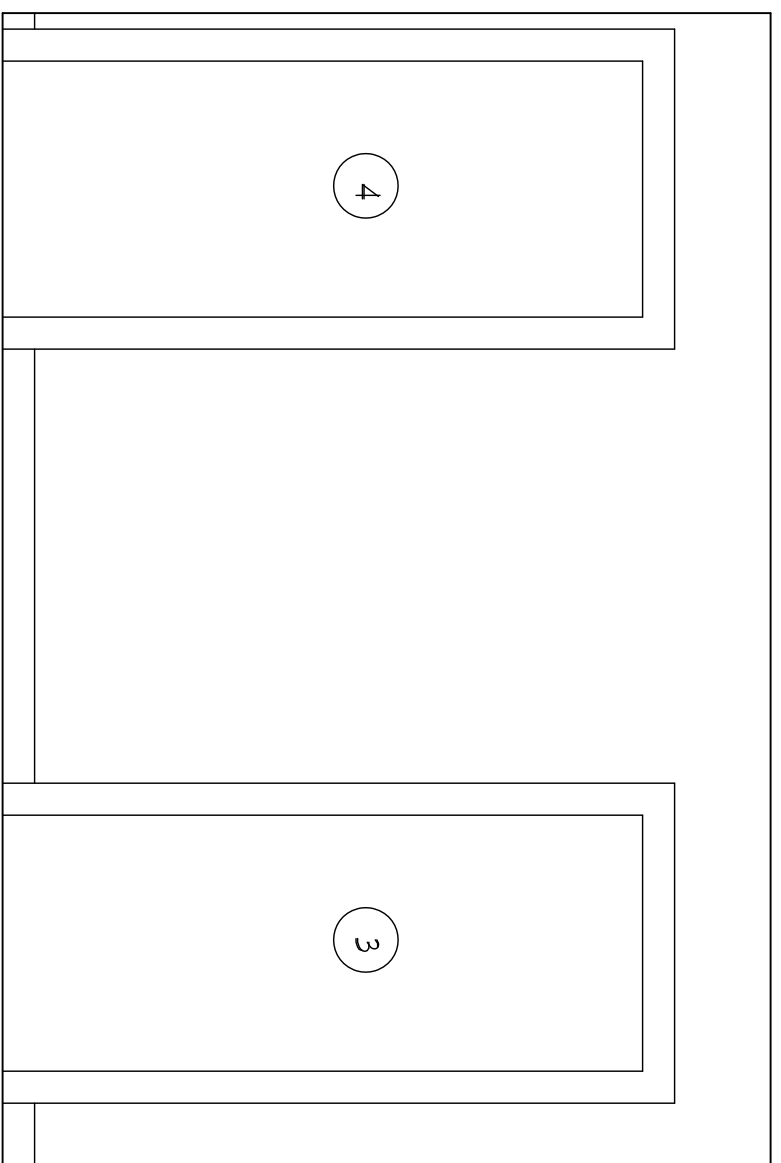

B LAV 109 - ELEVATION
SCALE: 1/2" = 1'-0"

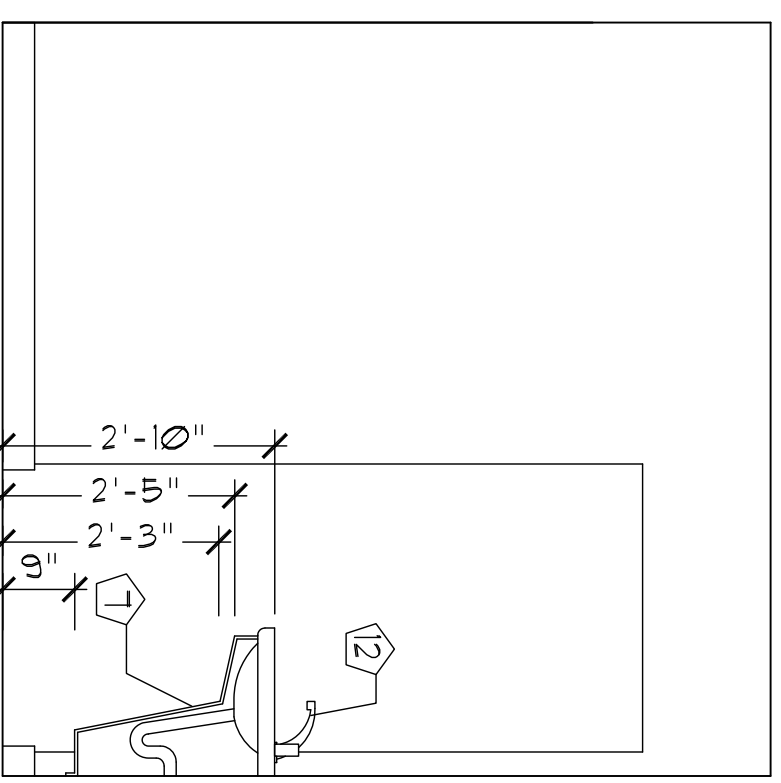

C LAV 109 - ELEVATION
SCALE: 1/2" = 1'-0"

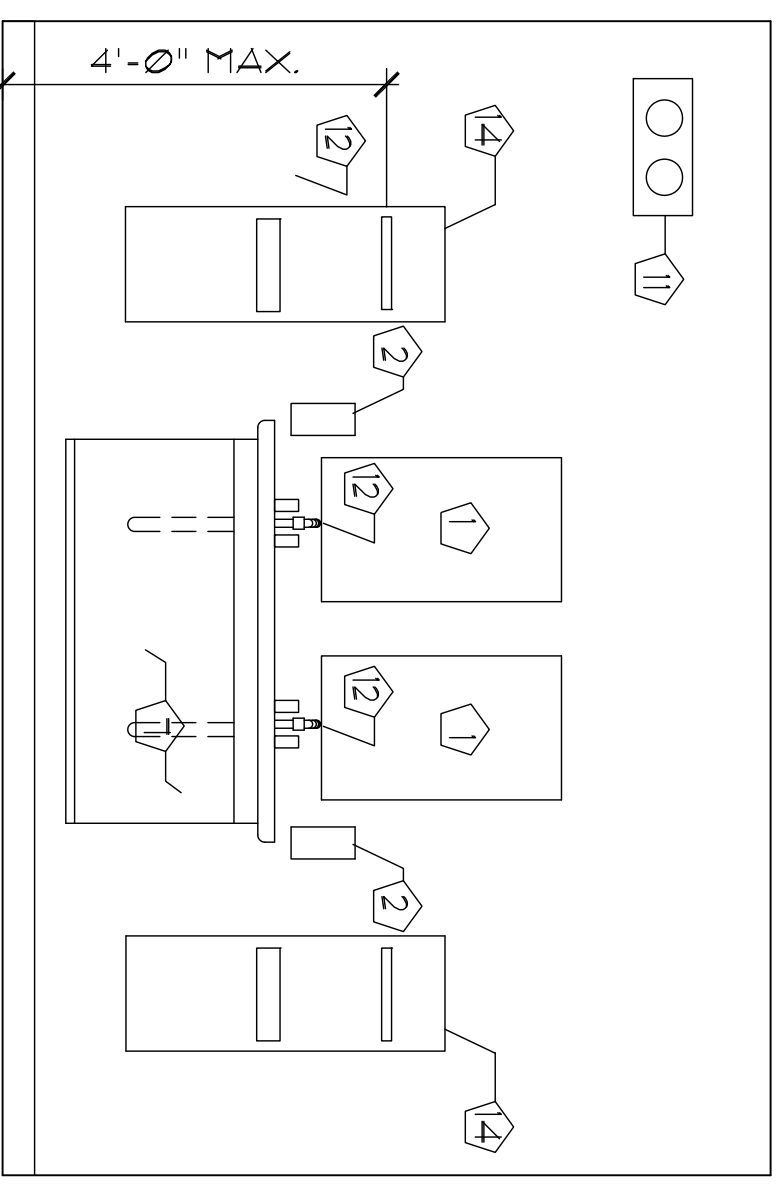

D LAV 109 - ELEVATION
SCALE: 1/2" = 1'-0"

GENERAL NOTE:
1. PROVIDE SOLID WOOD BLOCKING AT ALL WALL MOUNTED ITEMS.
2. PROVIDE ADA COMPLIANT FIXTURES - LAVATORIES, PIPE PROTECTION, GRAB BARS, FAUCETS, TOILETS, MIRRORS, SOAP DISPENSERS, TOILET TISSUE DISPENSERS, ETC.

- KEYED NOTES
- 1 36" X 24" MIRROR
 - 2 SOAP DISPENSER - MOUNT CONTROL AT 48"
 - 3 42" LONG GRAB BAR
 - 4 SOLID WOOD BLOCKING SHOWN DASHED
 - 5 TYPICAL TOILET TISSUE DISPENSER
 - 6 36" LONG GRAB BAR

- 7 ADA COMPLIANT PIPE PROTECTION.
- 8 30" X 48" CLEAR SPACE AT LAVATORY.
- 9 5'-0" DIAMETER TURNING CIRCLE.
- 10 3'-0" X 6'-0" DOOR
- 11 EMERGENCY LIGHT.
- 12 ADA COMPLIANT FAUCET.
- 13 NOT USED.
- 14 PAPER TOWEL DISPENSER - MOUNT 90 THAT TOILEL SLOT IS 48" AFF MAX.
- 15 MOP SINK
- 16 HOT WATER HEATER

Drawing
TOILET ROOM PLANS & ELEVATIONS

Project: INTERIOR FIT-UP
660 FOREST AVENUE
PORTLAND, MAINE

Date
10/xx/15

Revisions:
1 10/9/15 - toilet room layouts & elevations changed.

Scale
1/2" = 1'-0"

Architect
SHIELDS ARCHITECTURE
CUMBERLAND, MAINE
(207) 776-8926

Builder:
HARDYPOND CONSTRUCTION
7 TEE DRIVE
PORTLAND, MAINE 04103