

**Unit Dimensions - 3-10 Ton R410A PKGD Unitary Gas/Electric Rooftop**  
**Item: A1 Qty: 1**

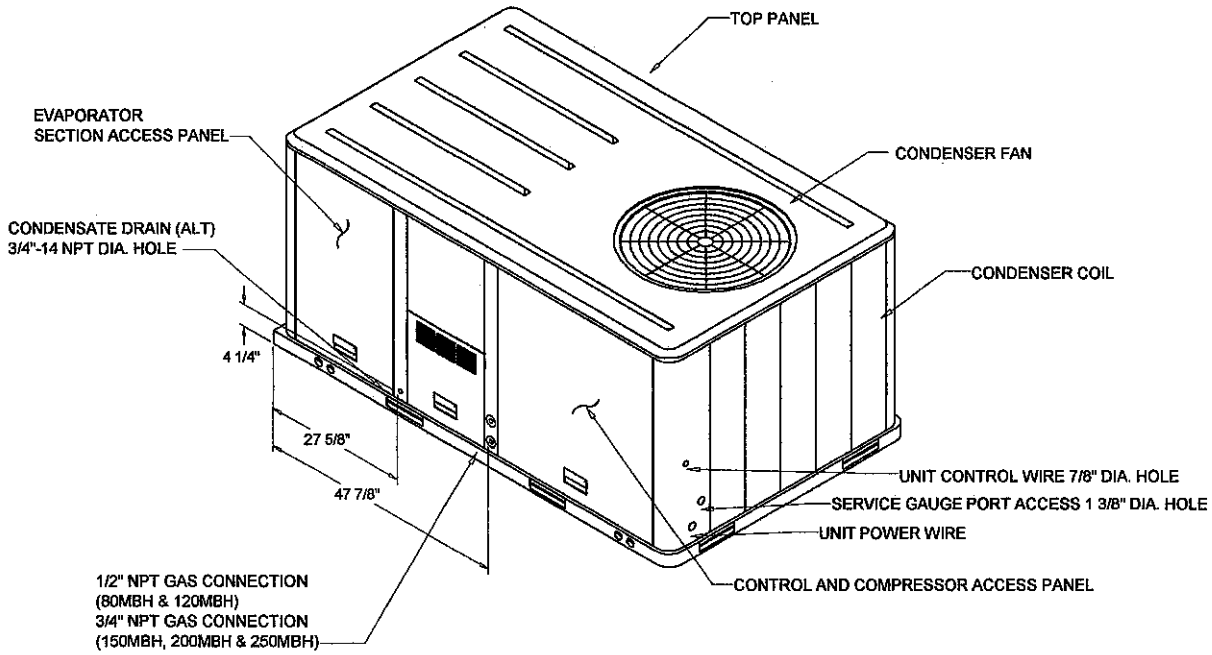

- NOTES:
1. THRU -THE -BASE ELECTRICAL AND GAS IS NOT STANDARD ON ALL UNITS.
  2. VERIFY WEIGHT, CONNECTION, AND ALL DIMENSION WITH INSTALLER DOCUMENTS BEFORE INSTALLATION

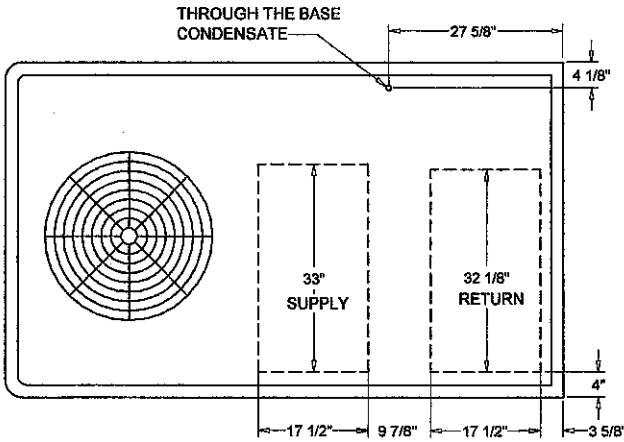

**PLAN VIEW UNIT**  
**DIMENSION DRAWING**

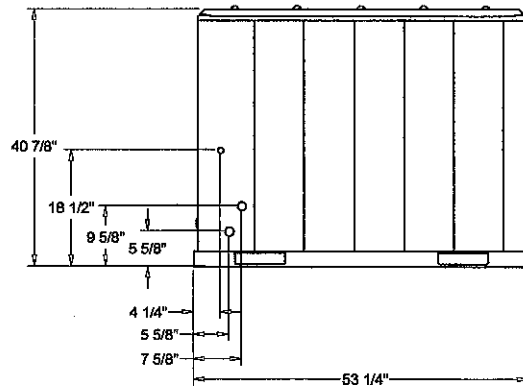
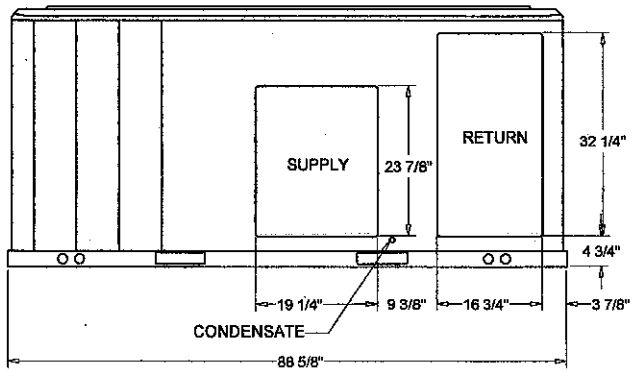

➔  
**HORIZONTAL AIR FLOW**

**PACKAGED GAS / ELECTRICAL**  
**DIMENSION DRAWING**