

DISPLAY THIS CARD ON PRINCIPAL FRONTAGE OF WORK



# CITY OF PORTLAND BUILDING PERMIT

This is to certify that DIANA LICHTON

Located At 88 CODMAN ST

Job ID: 2011-12-2955-HVAC

CBL: 128- A-018-001

has permission to Install DV Kozy Heat heater  
provided that the person or persons, firm or corporation accepting this permit shall comply with all of the provisions of the Statutes of Maine and of the Ordinances of the City of Portland regulating the construction, maintenance and use of the buildings and structures, and of the application on file in the department.

Notification of inspection and written permission procured before this building or part thereof is lathed or otherwise closed-in. 48 HOUR NOTICE IS REQUIRED.

A final inspection must be completed by owner before this building or part thereof is occupied. If a certificate of occupancy is required, it must be

**Fire Prevention Officer**

  
12/27/2011  
**Code Enforcement Officer / Plan Reviewer**

**THIS CARD MUST BE POSTED ON THE STREET SIDE OF THE PROPERTY  
PENALTY FOR REMOVING THIS CARD**

## BUILDING PERMIT INSPECTION PROCEDURES

Please call 874-8703 or 874-8693 (ONLY)

or email: [buildinginspections@portlandmaine.gov](mailto:buildinginspections@portlandmaine.gov)

With the issuance of this permit, the owner, builder or their designee is required to provide adequate notice to the city of Portland Inspections Services for the following inspections. Appointments must be requested 48 to 72 hours in advance of the required inspection. The inspection date will need to be confirmed by this office.

- **Please read the conditions of approval that is attached to this permit!! Contact this office if you have any questions.**
- **Permits expire in 6 months. If the project is not started or ceases for 6 months.**
- **If the inspection requirements are not followed as stated below additional fees may be incurred due to the issuance of a "Stop Work Order" and subsequent release to continue.**

Required Inspections:

1. Final Inspection upon completion of work.

The project cannot move to the next phase prior to the required inspection and approval to continue, REGARDLESS OF THE NOTICE OF CIRCUMSTANCES.

IF THE PERMIT REQUIRES A CERTIFICATE OF OCCUPANCY, IT MUST BE PAID FOR AND ISSUED TO THE OWNER OR DESIGNEE BEFORE THE SPACE MAY BE OCCUPIED.



# PORTLAND MAINE

*Strengthening a Remarkable City, Building a Community for Life* • [www.portlandmaine.gov](http://www.portlandmaine.gov)

Director of Planning and Urban Development  
Penny St. Louis

Job ID: 2011-12-2955-HVAC

Located At: 88 CODMAN ST

CBL: 128- A-018-001

## **Conditions of Approval:**

### **Building**

1. Application approval based upon information provided by applicant. Any deviation from approved plans requires separate review and approval prior to work.  
A copy of the enclosed chimney or fireplace disclosure must be submitted to this office upon completion of the permitted work or for the Certificate of Occupancy.
2. Ventilation of this space is required per ASRAE 62.2 or 62.1, 2007 edition.
3. Separate permits are required for any electrical, plumbing, sprinkler, fire alarm, HVAC systems, heating appliances, including pellet/wood stoves, commercial hood exhaust systems and fuel tanks. Separate plans may need to be submitted for approval as a part of this process.
4. The installation must comply with the State of Maine Gas Regulations. Maintain proper setback(s) from property lines/buildings and proper clearances from vertical openings when direct venting
5. This solid fuel appliance/stove/insert shall be installed, operated and maintained per the manufacturers specifications, the UL listing, NFPA 211 and IMC 2003.

**City of Portland, Maine - Building or Use Permit Application**

389 Congress Street, 04101 Tel: (207) 874-8703, FAX: (207) 8716

Job No: 2011-12-2955-HVAC	Date Applied: 12/20/2011	CBL: 128- A-018-001	
Location of Construction: 88 CODMAN ST	Owner Name: DIANA L ICHTON	Owner Address: 88 CODMAN ST PORTLAND, 04103 ME - MAINE	Phone:
Business Name:	Contractor Name: Nathan Leavitt	Contractor Address: 581 Main St., South Portland, ME 04106	Phone: (207) 329-2129
Lessee/Buyer's Name:	Phone:	Permit Type: HVAC	Zone: R-3
Past Use: Single Family Dwelling	Proposed Use: Same: Single Family Dwelling - to install Kozy Heat Fire Place heater	Cost of Work: \$1,000.00	CEO District:
		Fire Dept: <input type="checkbox"/> Approved <input checked="" type="checkbox"/> Denied <input type="checkbox"/> N/A	Inspection: Use Group: Type: <i>HVAR</i> Signature: <i>[Signature]</i>
Proposed Project Description: Install DV Kozy Heat heater		Pedestrian Activities District (P.A.D.)	
Permit Taken By: Lannie		<b>Zoning Approval</b>	

<p>1. This permit application does not preclude the Applicant(s) from meeting applicable State and Federal Rules.</p> <p>2. Building Permits do not include plumbing, septic or electrical work.</p> <p>3. Building permits are void if work is not started within six (6) months of the date of issuance. False informatin may invalidate a building permit and stop all work.</p>	<p><b>Special Zone or Reviews</b></p> <p><input type="checkbox"/> Shoreland</p> <p><input type="checkbox"/> Wetlands</p> <p><input type="checkbox"/> Flood Zone</p> <p><input type="checkbox"/> Subdivision</p> <p><input type="checkbox"/> Site Plan</p> <p><input type="checkbox"/> Maj <input type="checkbox"/> Min <input type="checkbox"/> MM</p> <p>Date: <i>12/21/11</i></p>	<p><b>Zoning Appeal</b></p> <p><input type="checkbox"/> Variance</p> <p><input type="checkbox"/> Miscellaneous</p> <p><input type="checkbox"/> Conditional Use</p> <p><input type="checkbox"/> Interpretation</p> <p><input type="checkbox"/> Approved</p> <p><input type="checkbox"/> Denied</p> <p>Date:</p>	<p><b>Historic Preservation</b></p> <p><input checked="" type="checkbox"/> Not in Dist or Landmark</p> <p><input type="checkbox"/> Does not Require Review</p> <p><input type="checkbox"/> Requires Review</p> <p><input type="checkbox"/> Approved</p> <p><input type="checkbox"/> Approved w/Conditions</p> <p><input type="checkbox"/> Denied</p> <p>Date: <i>[Signature]</i></p>
	<b>CERTIFICATION</b>		

I hereby certify that I am the owner of record of the named property, or that the proposed work is authorized by the owner of record and that I have been authorized by the owner to make this application as his authorized agent and I agree to conform to all applicable laws of this jurisdiction. In addition, if a permit for work described in the appication is issued, I certify that the code official's authorized representative shall have the authority to enter all areas covered by such permit at any reasonable hour to enforce the provision of the code(s) applicable to such permit.

SIGNATURE OF APPLICANT	ADDRESS	DATE	PHONE
RESPONSIBLE PERSON IN CHARGE OF WORK, TITLE		DATE	PHONE

**City of Portland, Maine - Building or Use Permit Application**

389 Congress Street, 04101 Tel: (207) 874-8703, FAX: (207) 8716

Job No: 2011-12-2955-HVAC	Date Applied: 12/20/2011	CBL: 128- A-018-001	
Location of Construction: 88 CODMAN ST	Owner Name: DIANA L ICHTON	Owner Address: 88 CODMAN ST PORTLAND, 04103 ME - MAINE	Phone:
Business Name:	Contractor Name: Nathan Leavitt	Contractor Address: 581 Main St., South Portland, ME 04106	Phone: (207) 329-2129
Lessee/Buyer's Name:	Phone:	Permit Type: HVAC	Zone: R-3
Past Use: Single Family Dwelling	Proposed Use: Same: Single Family Dwelling - to install Kozy Heat Fire Place heater	Cost of Work: \$1,000.00	CEO District:
		Fire Dept: <input type="checkbox"/> Approved <input checked="" type="checkbox"/> Denied <input checked="" type="checkbox"/> N/A	Inspection: Use Group: Type: <i>HVAC</i> Signature: <i>[Signature]</i>
Proposed Project Description: Install DV Kozy Heat heater		Pedestrian Activities District (P.A.D.)	
Permit Taken By: Lannie		<b>Zoning Approval</b>	

Special Zone or Reviews	Zoning Appeal	Historic Preservation
<input type="checkbox"/> Shoreland	<input type="checkbox"/> Variance	<input checked="" type="checkbox"/> Not in Dist or Landmark
<input type="checkbox"/> Wetlands	<input type="checkbox"/> Miscellaneous	<input type="checkbox"/> Does not Require Review
<input type="checkbox"/> Flood Zone	<input type="checkbox"/> Conditional Use	<input type="checkbox"/> Requires Review
<input type="checkbox"/> Subdivision	<input type="checkbox"/> Interpretation	<input type="checkbox"/> Approved
<input type="checkbox"/> Site Plan	<input type="checkbox"/> Approved	<input type="checkbox"/> Approved w/Conditions
<input type="checkbox"/> Maj <input type="checkbox"/> Min <input type="checkbox"/> MM	<input type="checkbox"/> Denied	<input type="checkbox"/> Denied
Date: <i>ok</i> <i>12/21/11</i>	Date:	Date: <i>[Signature]</i>

**CERTIFICATION**

I hereby certify that I am the owner of record of the named property, or that the proposed work is authorized by the owner of record and that I have been authorized by the owner to make this application as his authorized agent and I agree to conform to all applicable laws of this jurisdiction. In addition, if a permit for work described in the application is issued, I certify that the code official's authorized representative shall have the authority to enter all areas covered by such permit at any reasonable hour to enforce the provision of the code(s) applicable to such permit.

SIGNATURE OF APPLICANT	ADDRESS	DATE	PHONE
RESPONSIBLE PERSON IN CHARGE OF WORK, TITLE		DATE	PHONE



FILL IN AND SIGN WITH INK

# APPLICATION FOR PERMIT HEATING OR POWER EQUIPMENT



2011-12-29-55

128-A-18-

8800d'R-3

To the INSPECTOR OF BUILDINGS, PORTLAND, ME.

The undersigned hereby applies for a permit to install the following heating, cooking or power equipment in accordance with the Laws of Maine, the Building Code of the City of Portland, and the following specifications:

Location / CBL portland Use of Building \_\_\_\_\_ Date 12/20/11  
 Name and address of owner of appliance Diana Nelson  
88 COOman St Portland ME 04103  
 Installer's name and address Nathan Leavitt 581 main st south portland me 04166  
 Telephone 207 329 2129

**Location of appliance:**  
 Basement  Floor  
 Attic  Roof

**Type of Fuel:**  
 Gas  Oil  Solid

**Appliance Name:** Kozy Heat  
 U.L. Approved  Yes  No

Will appliance be installed in accordance with the manufacture's installation instructions?  Yes  No

IF NO Explain: \_\_\_\_\_

**The Type of License of Installer:**  
 Master Plumber # \_\_\_\_\_  
 Solid Fuel # \_\_\_\_\_  
 Oil # \_\_\_\_\_  
 Gas # PMT 3872  
 Other \_\_\_\_\_

**Type of Chimney:**  
 Masonry Lined  
 Factory built \_\_\_\_\_  
 Metal  
 Factory Built U.L. Listing # \_\_\_\_\_  
 Direct Vent  
 Type Factory Built UL# \_\_\_\_\_

**Type of Fuel Tank**  
 Oil  
 Gas

**Size of Tank** \_\_\_\_\_

**Number of Tanks** \_\_\_\_\_

**Distance from Tank to Center of Flame** \_\_\_\_\_ feet.

**Cost of Work:** \$ 375.00  
**Permit Fee:** \$ 30

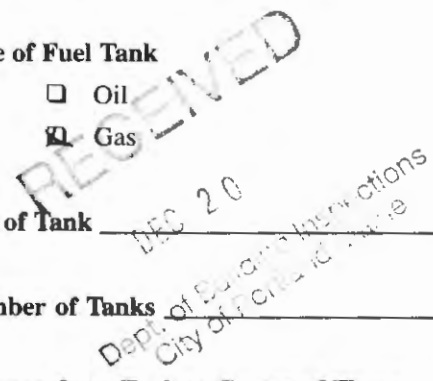

**Approved**

Fire: \_\_\_\_\_  
 Ele.: \_\_\_\_\_  
 Bldg.: \_\_\_\_\_

**Signature of Installer** [Signature]

**Approved with Conditions**

See attached letter or requirement

\_\_\_\_\_  
 Inspector's Signature Date Approved \_\_\_\_\_





FIREPLACES

Quality Fireplaces for Life

Models: #PRC-36  
#PRC-36-RF  
#PRC-36-IPI

# PRINCETON - PRC

DIRECT VENT FIREPLACE

**WARNING:** This product must be installed by a licensed plumber or gas fitter when installed in the Commonwealth of Massachusetts.

**IMPORTANT:** Installation of a CO detector is required in the fireplace room when installed in the Commonwealth of Massachusetts.

## INSTALLATION AND OPERATION MANUAL

INSTALLER: LEAVE THIS MANUAL WITH THE APPLIANCE.  
CONSUMER: RETAIN THIS MANUAL FOR FUTURE REFERENCE.

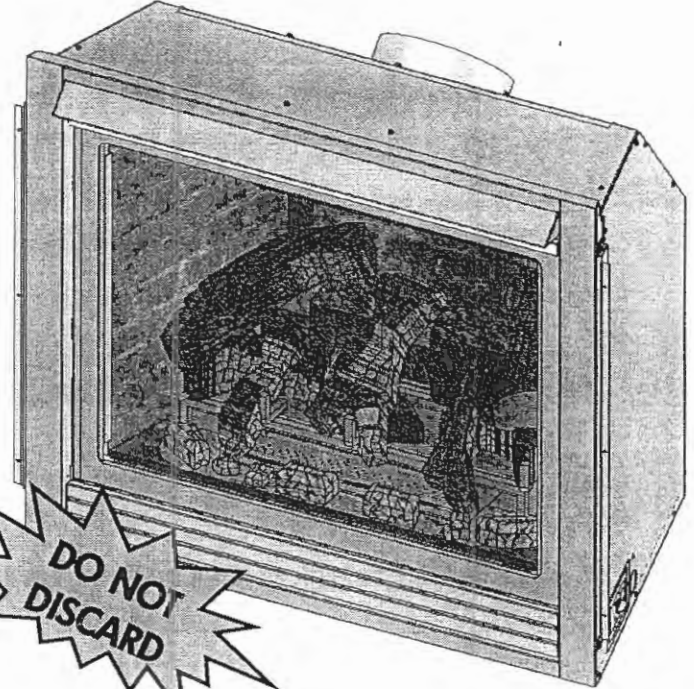

**WARNING:** If the information in these instructions are not followed exactly, a fire or explosion may result, causing property damage, personal injury or loss of life.

- Do not store or use gasoline or other flammable vapors and liquids in the vicinity of this or any other appliance.

### IF YOU SMELL GAS:

- Do not light any appliance.
- Do not touch any electrical switch; do not use any phone in your building.
- Immediately call gas supplier from a neighbors phone. Follow the gas supplier instructions.
- If you cannot reach your gas supplier, call the fire department.
- Installation and service must be performed by a qualified installer, service agency or the gas supplier.

This appliance may be installed in an aftermarket permanently located, manufactured (mobile) home, where not prohibited by local codes.

This appliance is only for use with the type (s) of gas indicated on the rating plate. A conversion kit is supplied with the appliance.



www.kozyheat.com



We recommend that our gas hearth products be installed and serviced by professionals who are certified in the U.S. by the National Fireplace Institute® (NFI) as NFI Gas Specialists.

October 2009  
PRC-R08

# TYPICAL INSTALLATION OPTIONS



**IMPORTANT:** KOZY HEAT WALL THIMBLE PASS-THRU (#800-WPT or #800-WPT2) MUST BE USED ON ALL HORIZONTAL VENT RUNS. FOLLOW INSTRUCTIONS ON PAGE 23 OF THIS INSTALLATION MANUAL.

**IMPORTANT:** THE HORIZONTAL HEAT SHIELD INCLUDED WITH THIS FIREPLACE MUST BE INSTALLED WHEN USING A 45-DEGREE ELBOW DIRECTLY OFF TOP OF UNIT TO HORIZONTALLY POSITION VENT SYSTEM. EXCEPTION: CORNER INSTALLATIONS.



**NOTE:** HORIZONTAL VENT HEAT SHIELD NOT SHOWN FOR CLARITY PURPOSES ONLY.

\* Illustration at right requires a minimum 5" (127 mm) exterior wall depth when using minimum horizontal venting. Anything less than a 5" (127 mm) exterior wall depth requires that you add that depth to the 21-7/8" (556 mm) dimension to accommodate minimum venting.

## TYPICAL HORIZONTAL INSTALLATION

5" (127 mm) exterior wall depth shown\*

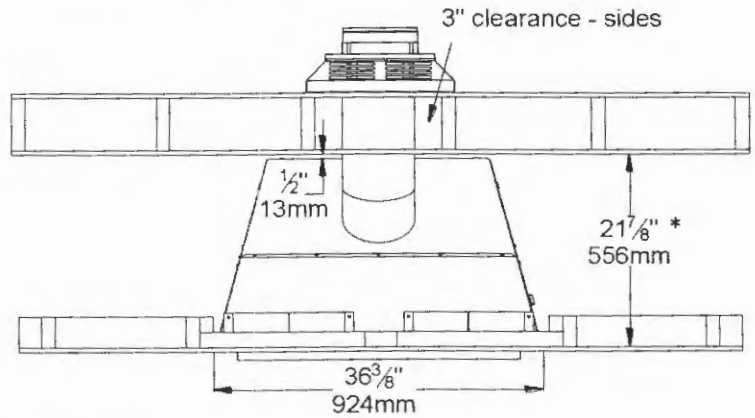

## TYPICAL CORNER INSTALLATION

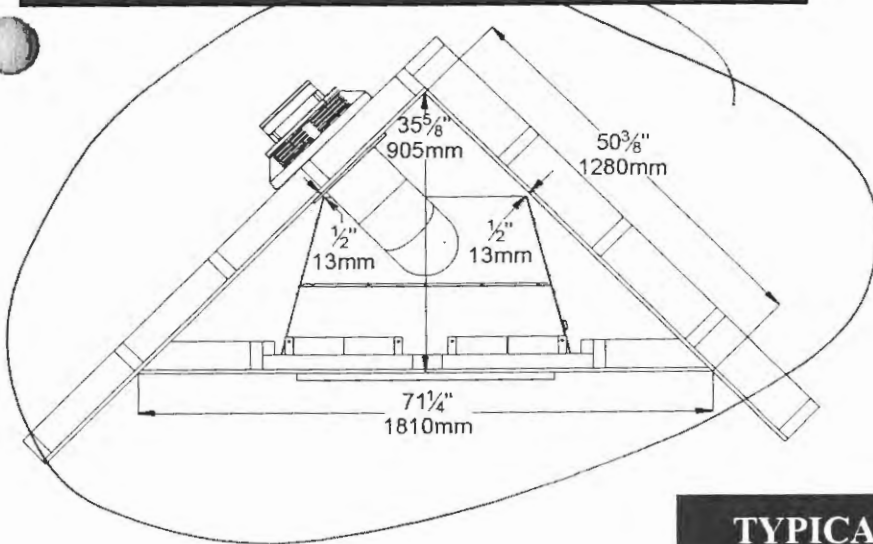

## TYPICAL VERTICAL INSTALLATION

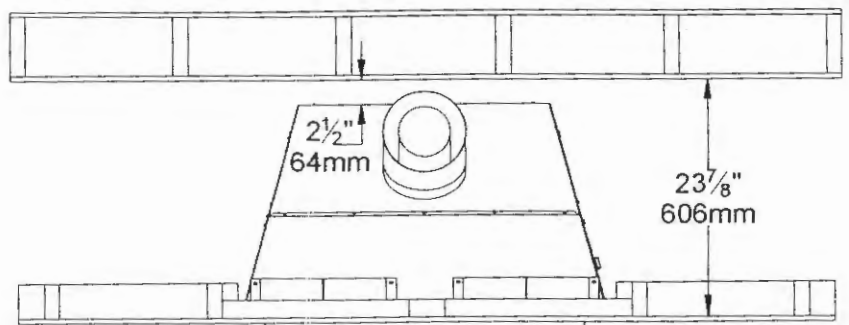





# CITY OF PORTLAND, MAINE

Department of Building Inspections

## Original Receipt

12-20 2011

Received from Nathan Leavitt

Location of Work 88 Colver St

Cost of Construction \$ \_\_\_\_\_ Building Fee: \_\_\_\_\_

Permit Fee \$ \_\_\_\_\_ Site Fee: \_\_\_\_\_

Certificate of Occupancy Fee: \_\_\_\_\_

Total: 30

Building (IL) \_\_\_\_\_  Plumbing (I5) \_\_\_\_\_  Electrical (I2) \_\_\_\_\_  Site Plan (U2) \_\_\_\_\_

Other \_\_\_\_\_

CBL: 129-A 13

Check #: cash Total Collected \$ 30

**No work is to be started until permit issued.  
Please keep original receipt for your records.**

Taken by: [Signature]

WHITE - Applicant's Copy  
YELLOW - Office Copy  
PINK - Permit Copy