

City of Portland, Maine – Building or Use Permit Application 389 Congress Street, 04101, Tel: (207) 874-8703, FAX: 874-8716

Location of Construction: 501 Forest Avenue Ptld, ME		Owner: Laura George		Phone: 774-1482	
Owner Address: SAA		Lessee/Buyer's Name:		Phone:	
* Contractor Name: Houses & Barns (John Libby)		Address: P.O. Box 258 Freeport, ME 04032		Phone: 865-4169	
Past Use: Business		Proposed Use: Same		COST OF WORK: \$ 10,000 PERMIT FEE: \$ 70,000	
Proposed Project Description: Repair Roof		FIRE DEPT. <input checked="" type="checkbox"/> Approved <input type="checkbox"/> Denied Signature: <i>[Signature]</i>		INSPECTION: Use Group: <i>B</i> Type: <i>BOCA</i> Signature: <i>[Signature]</i>	
Permit Taken By: <i>SP</i>		Date Applied For: 11-2-98		PEDESTRIAN ACTIVITIES DISTRICT (P.A.D.) Action: <input checked="" type="checkbox"/> Approved <input type="checkbox"/> Approved with Conditions <input type="checkbox"/> Denied Signature: _____ Date: _____	

Permit No: **981267**

PERMIT ISSUED

Permit Issued:
NOV 6 1998

CITY OF PORTLAND

Zone: *B-2* CBL: 127-A-005

Zoning Approval: *[Signature]* 11/3/98

Special Zone or Reviews:

Shoreland
 Wetland
 Flood Zone
 Subdivision
 Site Plan maj minor mm

1. This permit application does not preclude the Applicant(s) from meeting applicable State and Federal rules.
2. Building permits do not include plumbing, septic or electrical work.
3. Building permits are void if work is not started within six (6) months of the date of issuance. False information may invalidate a building permit and stop all work..

Zoning Appeal

Variance
 Miscellaneous
 Conditional Use
 Interpretation
 Approved
 Denied

Historic Preservation

Not in District or Landmark
 Does Not Require Review
 Requires Review

CERTIFICATION

I hereby certify that I am the owner of record of the named property, or that the proposed work is authorized by the owner of record and that I have been authorized by the owner to make this application as his authorized agent and I agree to conform to all applicable laws of this jurisdiction. In addition, if a permit for work described in the application is issued, I certify that the code official's authorized representative shall have the authority to enter all areas covered by such permit at any reasonable hour to enforce the provisions of the code(s) applicable to such permit

Action:

Approved
 Approved with Conditions
 Denied

Date: *[Signature]*

SIGNATURE OF APPLICANT _____ ADDRESS: _____ DATE: 11-3-98 PHONE: _____

RESPONSIBLE PERSON IN CHARGE OF WORK, TITLE _____ PHONE: _____

CEO DISTRICT 2

THIS IS NOT A PERMIT/CONSTRUCTION CANNOT COMMENCE UNTIL THE PERMIT IS ISSUED

**Building or Use Permit Pre-Application
Attached Single Family Dwellings/Two-Family Dwelling
Multi-Family or Commercial Structures and Additions Thereto**

In the interest of processing your application in the quickest possible manner, please complete the Information below for a Building or Use Permit.

NOTEIf you or the property owner owes real estate or personal property taxes or user charges on ANY PROPERTY within the City, payment arrangements must be made before permits of any kind are accepted.**

Location/Address of Construction (include Portion of Building): <i>501 Forest Ave Ptd</i>		
Total Square Footage of Proposed Structure		Square Footage of Lot
Tax Assessor's Chart, Block & Lot Number Chart# <i>127</i> Block# <i>A</i> Lot# <i>5</i>	Owner: <i>Laura George</i>	Telephone#: <i>774-1482</i>
Owner's Address: <i>501 Forest Ave Laura George Ptd</i>	Lessee/Buyer's Name (If Applicable)	Cost Of Work: <i>\$10,000</i> Fee: <i>\$70-</i>
Proposed Project Description: (Please be as specific as possible) <i>Repair one roof purlin which failed & broke</i>		
Contractor's Name, Address & Telephone <i>Houses & Barns by John Libby PO Box 258 Freeport ME 04032 865-4169</i> Rec'd By <i>[Signature]</i>		
Current Use: <i>Business Form Co.</i>	Proposed Use: <i>Same</i>	

Separate permits are required for Internal & External Plumbing, HVAC and Electrical installation

- All construction must be conducted in compliance with the 1996 B.O.C.A. Building Code as amended by Section 6-Art II.
- All plumbing must be conducted in compliance with the State of Maine Plumbing Code.
- All Electrical Installation must comply with the 1996 National Electrical Code as amended by Section 6-Art III.
- HVAC (Heating, Ventilation and Air Conditioning) installation must comply with the 1993 BOCA Mechanical Code.

You must Include the following with you application:

- 1) A Copy of Your Deed or Purchase and Sale Agreement
- 2) A Copy of your Construction Contract, if available
- 3) A Plot Plan/Site Plan

Minor or Major site plan review will be required for the above proposed projects. The attached checklist outlines the minimum standards for a site plan.

4) Building Plans

Unless exempted by State Law, construction documents must be designed by a registered design professional.

A complete set of construction drawings showing all of the following elements of construction:

- Cross Sections w/Framing details (including porches, decks w/ railings, and accessory structures)
- Floor Plans & Elevations
- Window and door schedules
- Foundation plans with required drainage and dampproofing
- Electrical and plumbing layout. Mechanical drawings for any specialized equipment such as furnaces, chimneys, gas equipment, HVAC equipment (air handling) or other types of work that may require special review must be included.

Certification

I hereby certify that I am the Owner of record of the named property, or that the proposed work is authorized by the owner of record and that I have been authorized by the owner to make this application as his/her authorized agent. I agree to conform to all applicable laws of this jurisdiction. In addition, if a permit for work described in this application is issued, I certify that the Code Official's authorized representative shall have the authority to enter all areas covered by this permit at any reasonable hour to enforce the provisions of the codes applicable to this permit.

Signature of applicant: <i>[Signature]</i>	Date: <i>11/2/98</i>
--	----------------------

Building Permit Fee: \$25.00 for the 1st \$1000. cost plus \$5.00 per \$1,000.00 construction cost thereafter.

Additional Site review and related fees are attached on a separate addendum





Repair Area



X

501 Forest Ave

FOREST AVE

DARTMOUTH ST



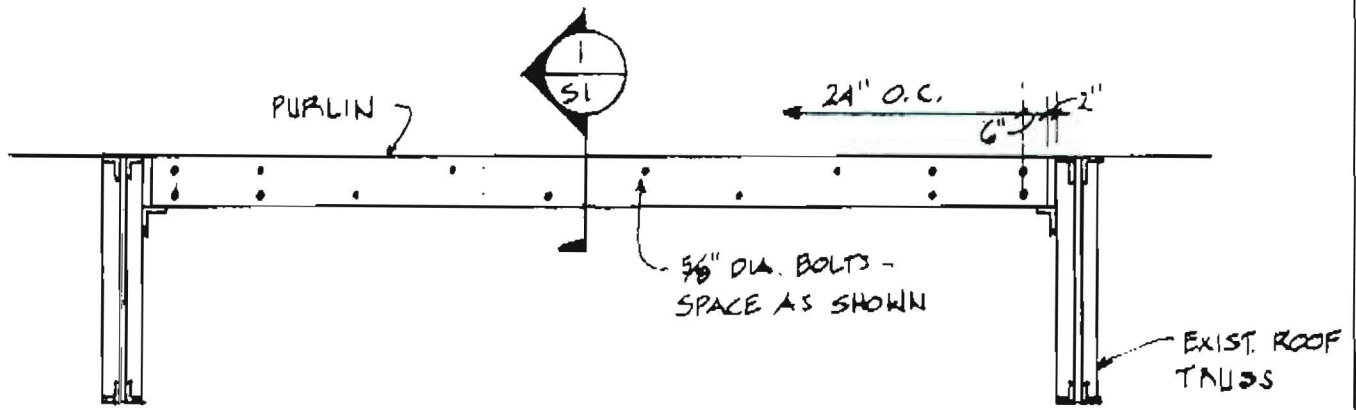

PURLIN ELEVATION

1/4" = 1'-0"

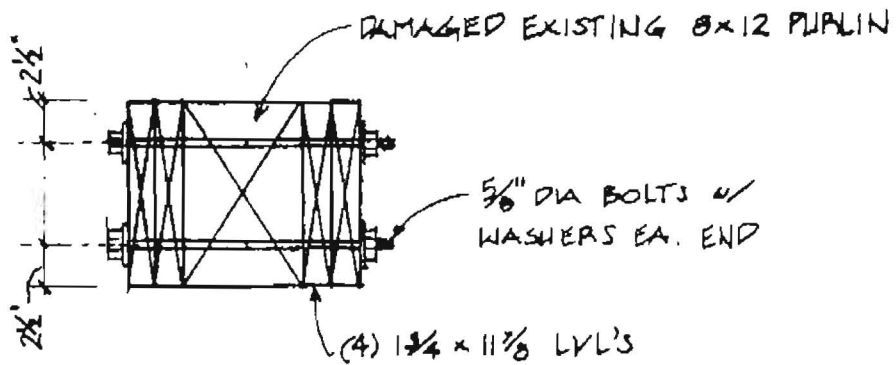

① PURLIN SECTION

1" = 1'-0"

Title: FAILED ROOF BEAM REPAIR
 GBF INFO SYSTEMS
 501 FOREST AVE, PORTLAND, ME.

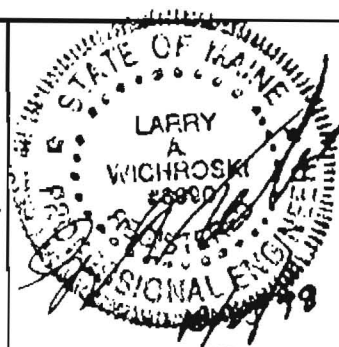

Job No: 03098
 Date: 10-26-98
 Name: LAW
 Sheet: S-1



ENGINEERING DESIGN PROFESSIONALS
 Consulting Engineers
 P.O. Box 575, Freeport, Maine 04032 (207)865-9505