

630
FOREST
AVENUE
KEY PLAN



FOREST AVENUE

FOODIE
FRIENDS
MARKET

JOCELYN
LEE
STUDIO
(Area of Renovation)

SPEEDWELL
PROJECTS
ART GALLERY

BAKERY
PHOTOGRAPHY
COLLECTIVE
STUDIO



Reviewed for Code Compliance
Permitting and Inspections Department
Approved with Conditions
03/12/2019

KEY PLAN INDICATING ADJACENT TENANT USES AT 630 FOREST AVENUE



Reviewed for Code Compliance
 Permitting and Inspections Department
 Approved with Conditions
 03/12/2019

CODE REVIEW:

Area: 1,558 SF
 Occupancy: B Business
 - 100 sf Per person
 Occupant load: 15 people
 Type V Construction
 Sprinkled: yes

Maximum Distance to Exit: 300'
 Provided: 41.5'
 Required Egress Width: MIN 36"
 Provided: 36"

SPEEDWELL PROJECTS
 FOREST AVE, PORTLAND ME

JAMES BEASLEY
 ARCHITECTURE
 1 PLEASANT VALLEY AVE
 CAPE ELIZABETH ME, 04107

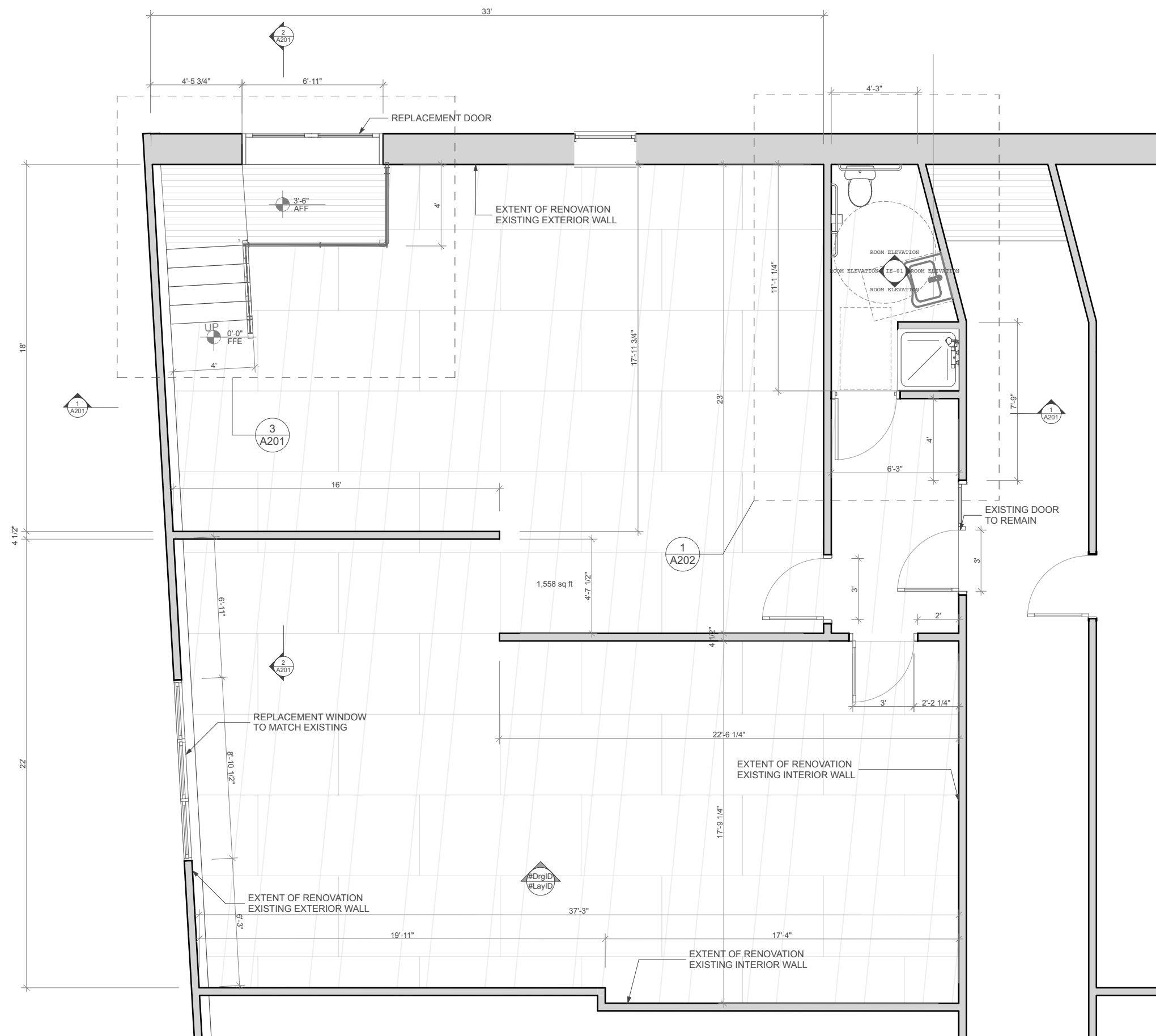

FLOOR PLAN

SCALE: 3/16" = 1'-0"

FLOOR PLAN

2/20/19

A101

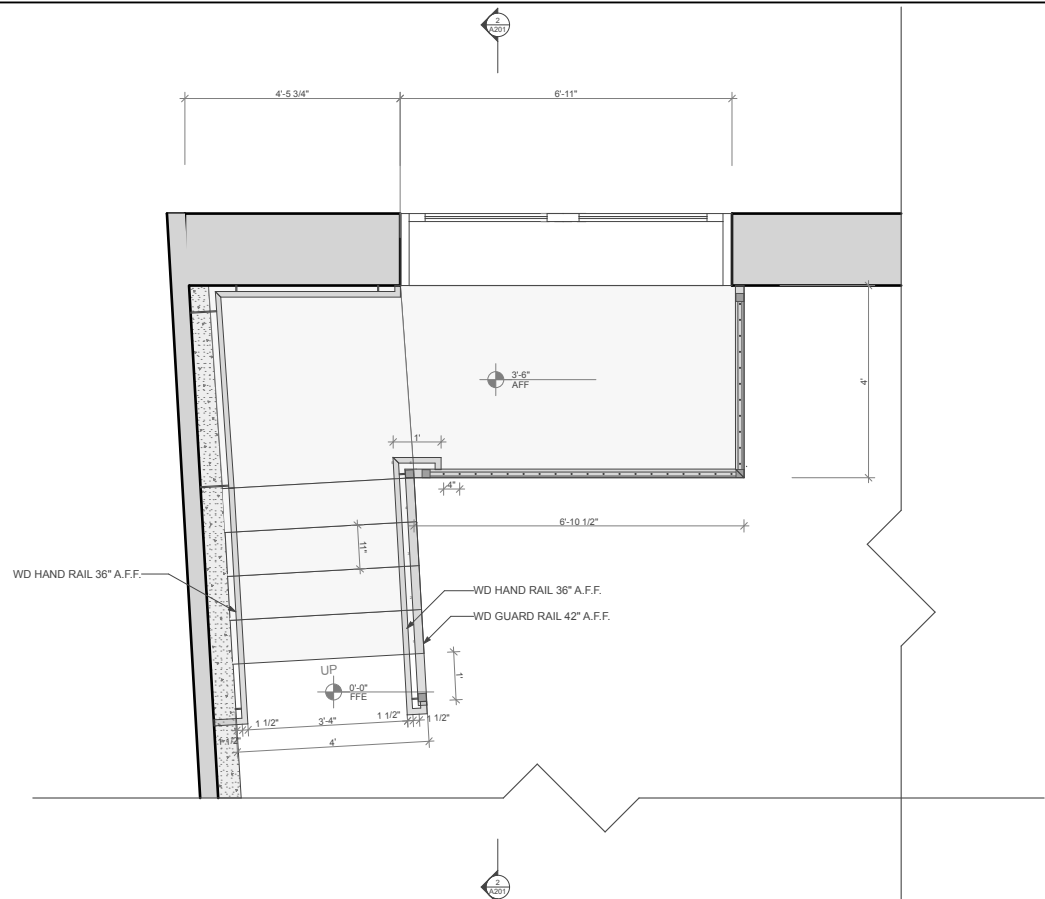

FLOOR PLAN
SCALE: 1/4" = 1'-0"

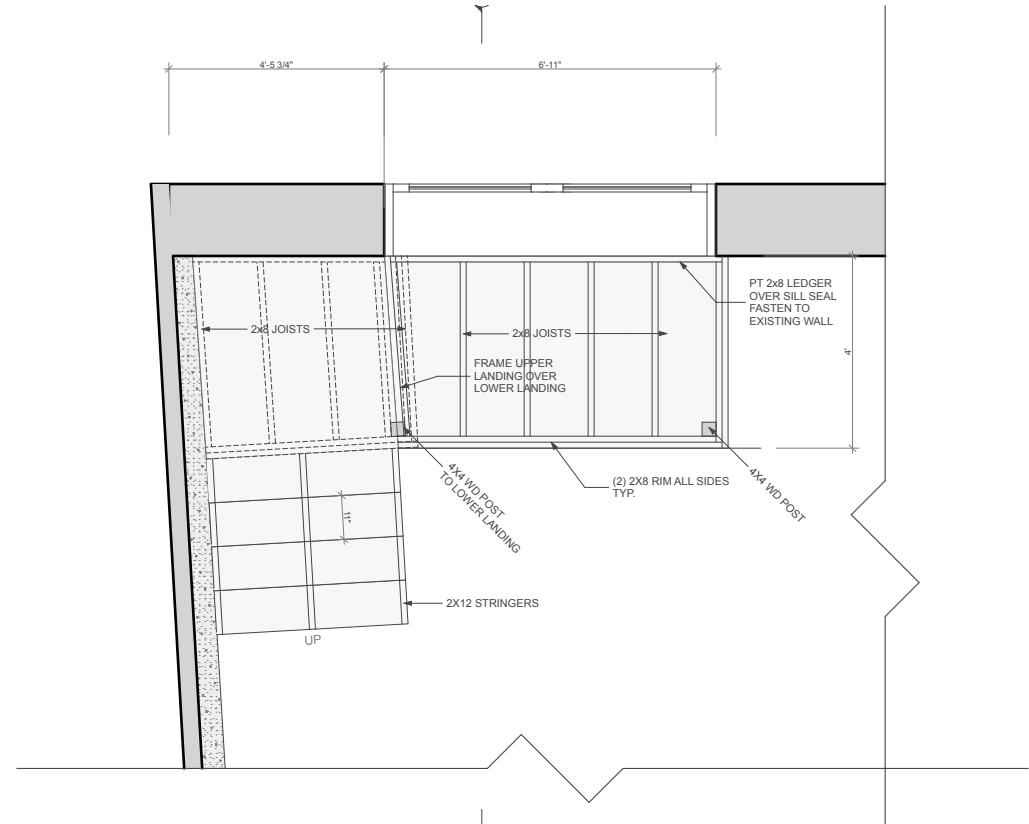

FRAMING PLAN
SCALE: 1/4" = 1'-0"

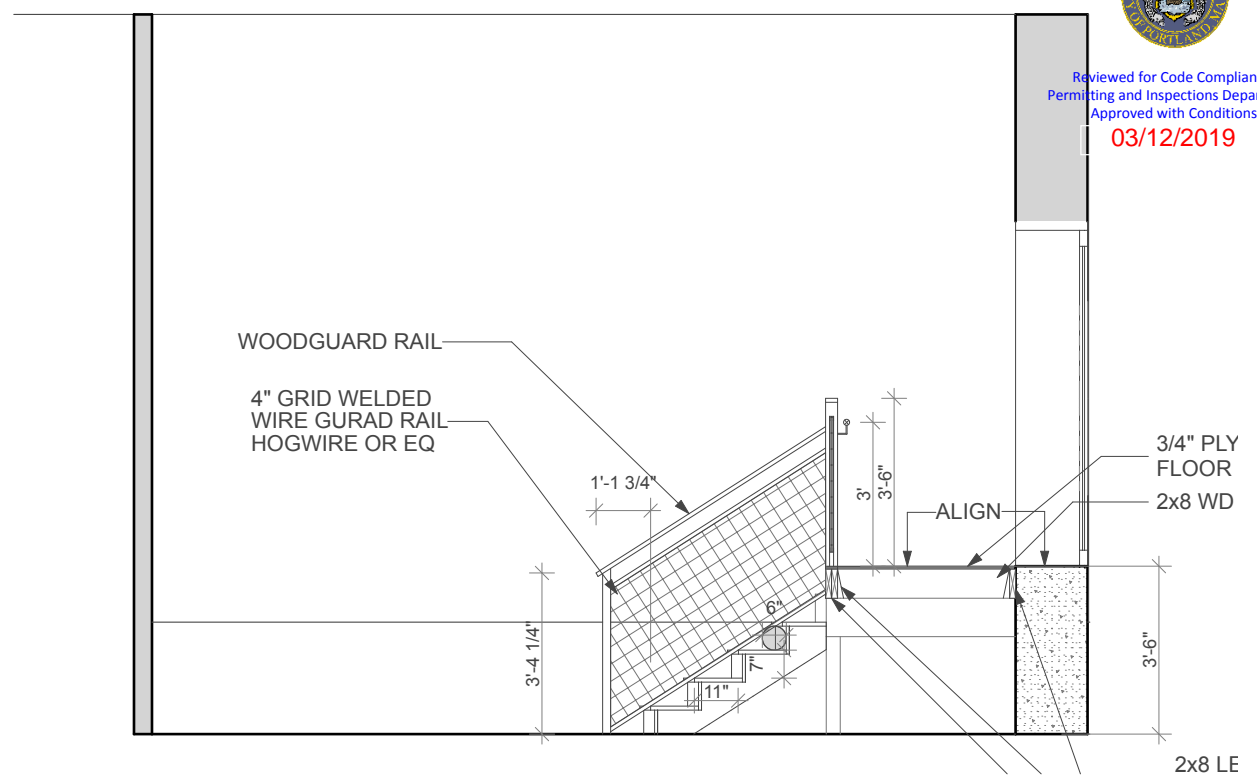

STAIR ELEVATION/SECTION
SCALE: 1/4" = 1'-0"

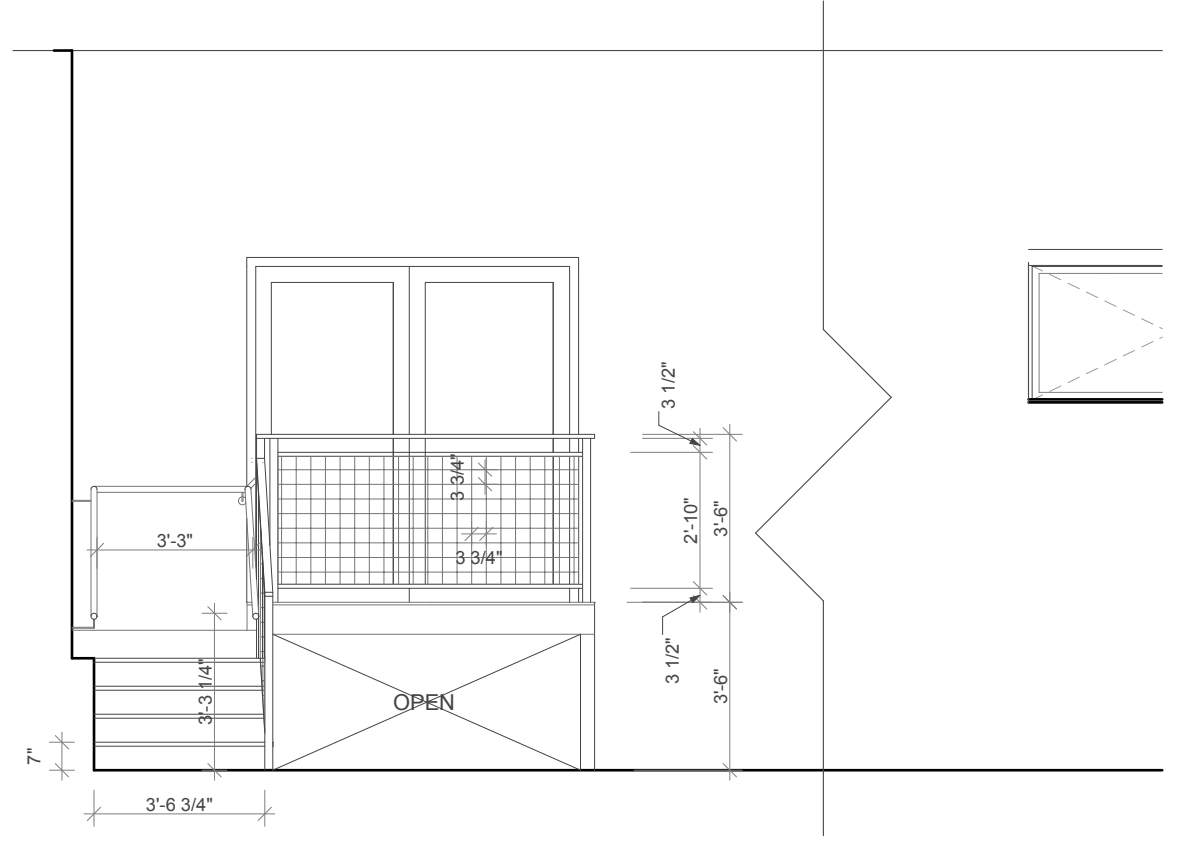

STAIR SECTION/ELEVATION
SCALE: 1/4" = 1'-0"



Reviewed for Code Compliance
Permitting and Inspections Department
Approved with Conditions
03/12/2019

SPEEDWELL PROJECTS
FOREST AVE, PORTLAND ME

JAMES BEASLEY
ARCHITECTURE
1 PLEASANT VALLEY AVE
CAPE ELIZABETH ME, 04107

STAIR
2/20/19

A201



Reviewed for Code Compliance
 Permitting and Inspections Department
 Approved with Conditions
 03/12/2019

SPEEDWELL PROJECTS
 FOREST AVE, PORTLAND ME

JAMES BEASLEY
 ARCHITECTURE
 1 PLEASANT VALLEY AVE
 CAPE ELIZABETH ME, 04107

BATHROOM

2/20/19

A202

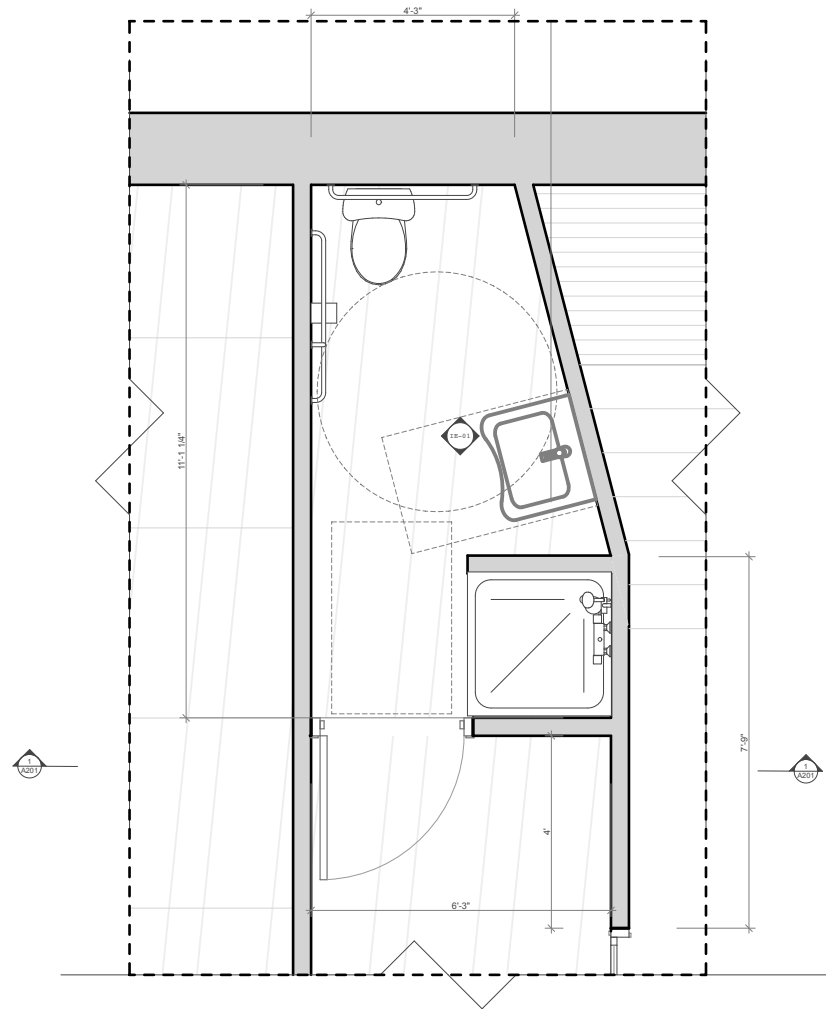

BATH FLOOR PLAN

SCALE: 1/4" = 1'-0"

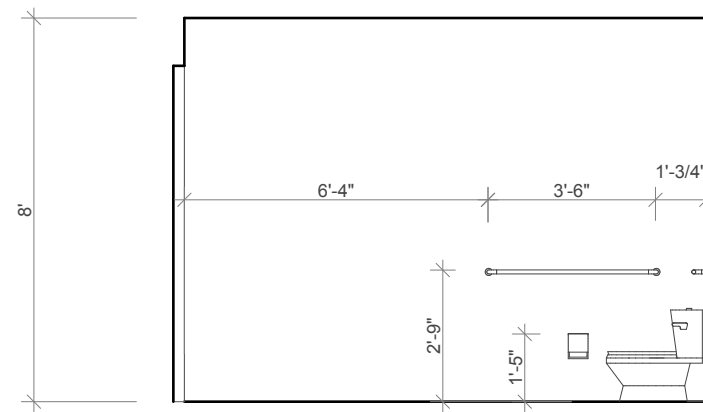

STUDIO WALL ELEVATION

SCALE: 1/4" = 1'-0"

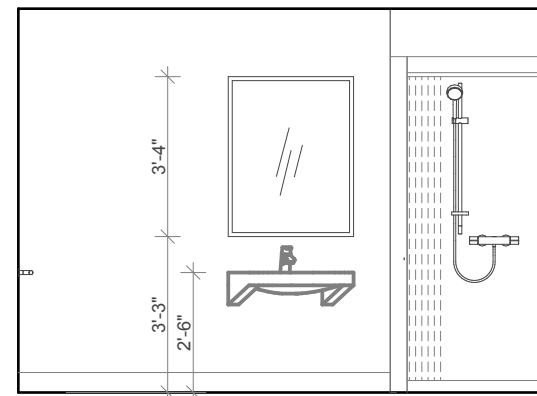

CORRIDOR WALL ELEVATION

SCALE: 1/4" = 1'-0"

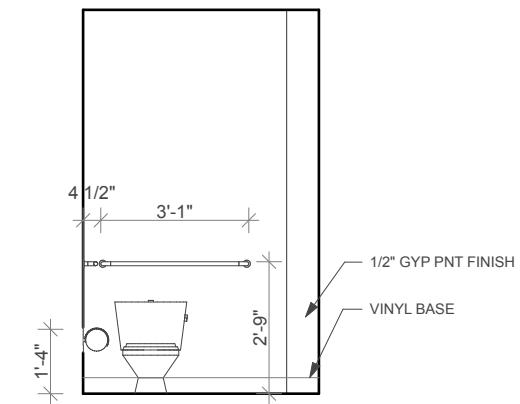

TOILET WALL ELEVATION

SCALE: 1/4" = 1'-0"

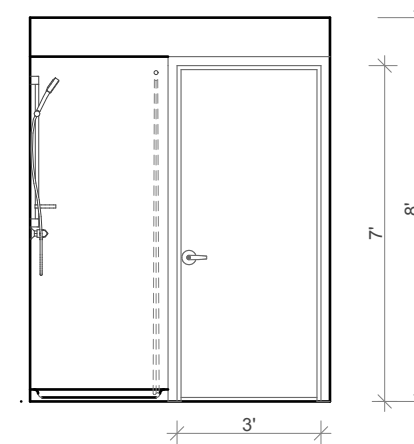

ENTRY WALL

SCALE: 1/4" = 1'-0"



LIFE PLAN
 Reviewed for Code Compliance
 Permitting and Inspections Department
 Approved with Conditions
 03/12/2019

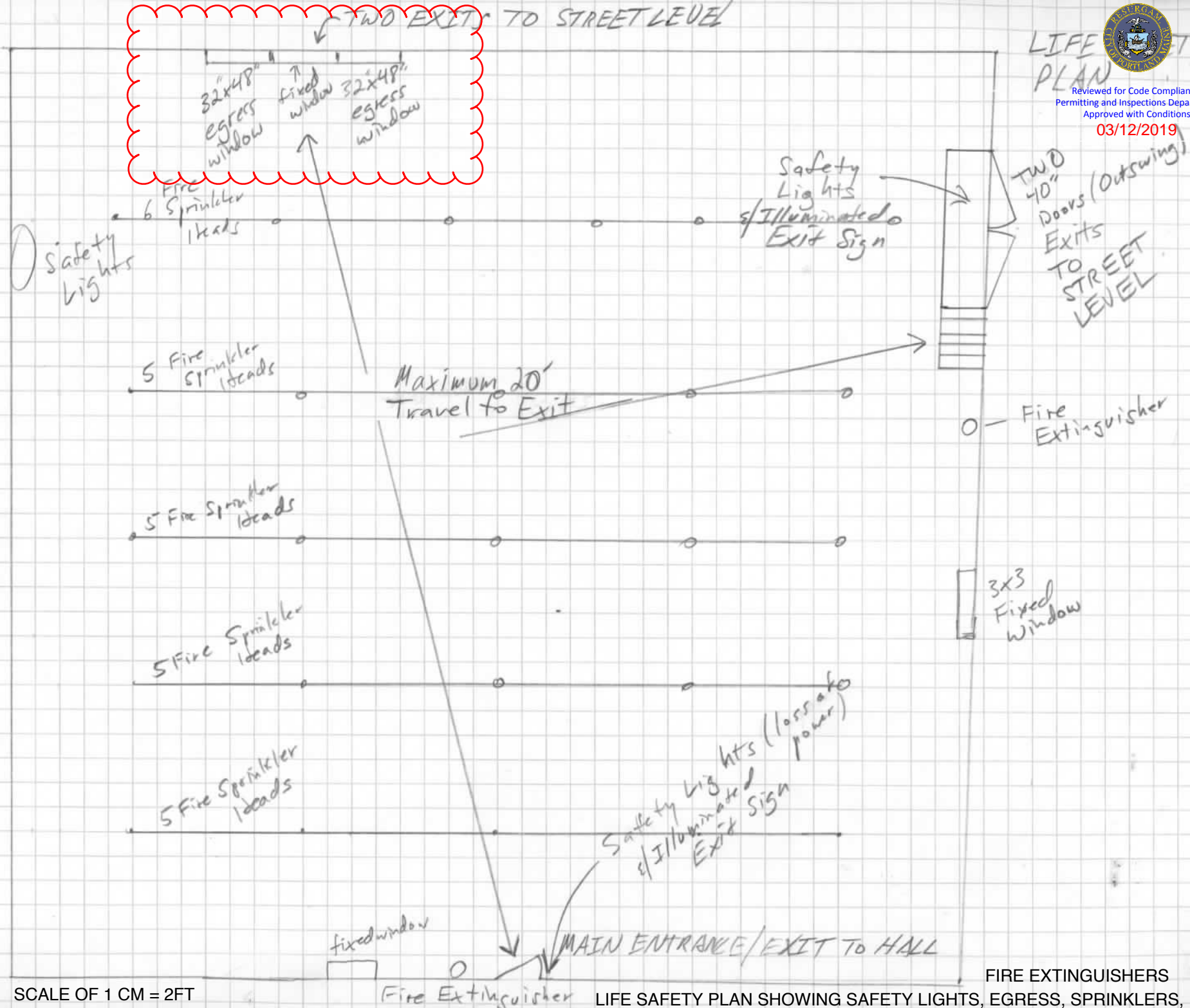

SCALE OF 1 CM = 2FT

FIRE EXTINGUISHERS
 LIFE SAFETY PLAN SHOWING SAFETY LIGHTS, EGRESS, SPRINKLERS,