

DRAWINGS/SPECIFICATIONS BY:  
 WALGREENS'  
 LANDLORD'S CONSULTANT  
 ALL CONSTRUCTION WORK, UNLESS NOTED OTHERWISE, BY:  
 WALGREENS' CONTRACTOR  
 LANDLORD'S CONTRACTOR (TURNKEY CONSTRUCTION)

STORE	BUILDING
NEW . . . . . <input checked="" type="checkbox"/>	NEW . . . . . <input checked="" type="checkbox"/>
REMODELING . . . . . <input type="checkbox"/>	EXISTING . . . . . <input type="checkbox"/>
RELOCATION . . . . . <input type="checkbox"/>	NEW SHELL ONLY . . . . . <input type="checkbox"/>
OTHERS . . . . . <input type="checkbox"/>	

STRUCTURAL ENGINEER:  
**DWD ENGINEERING, INC.**

5 Michael Road  
 E. Bridgewater, MA  
 TEL. 508.378.9602  
 FAX. 508.378.2922

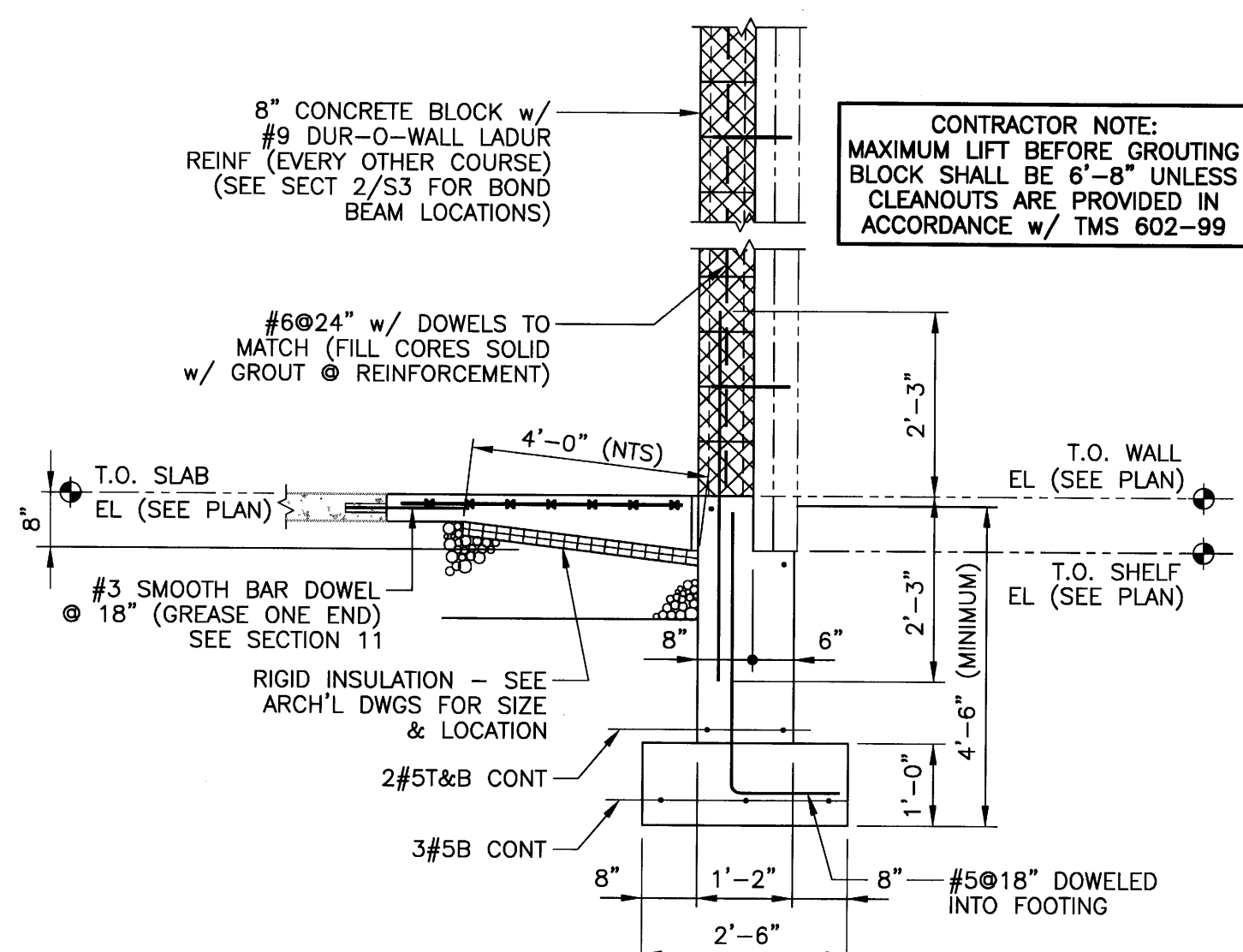

**7 SECTION**  
 S1 SCALE: 1/2"=1'-0"

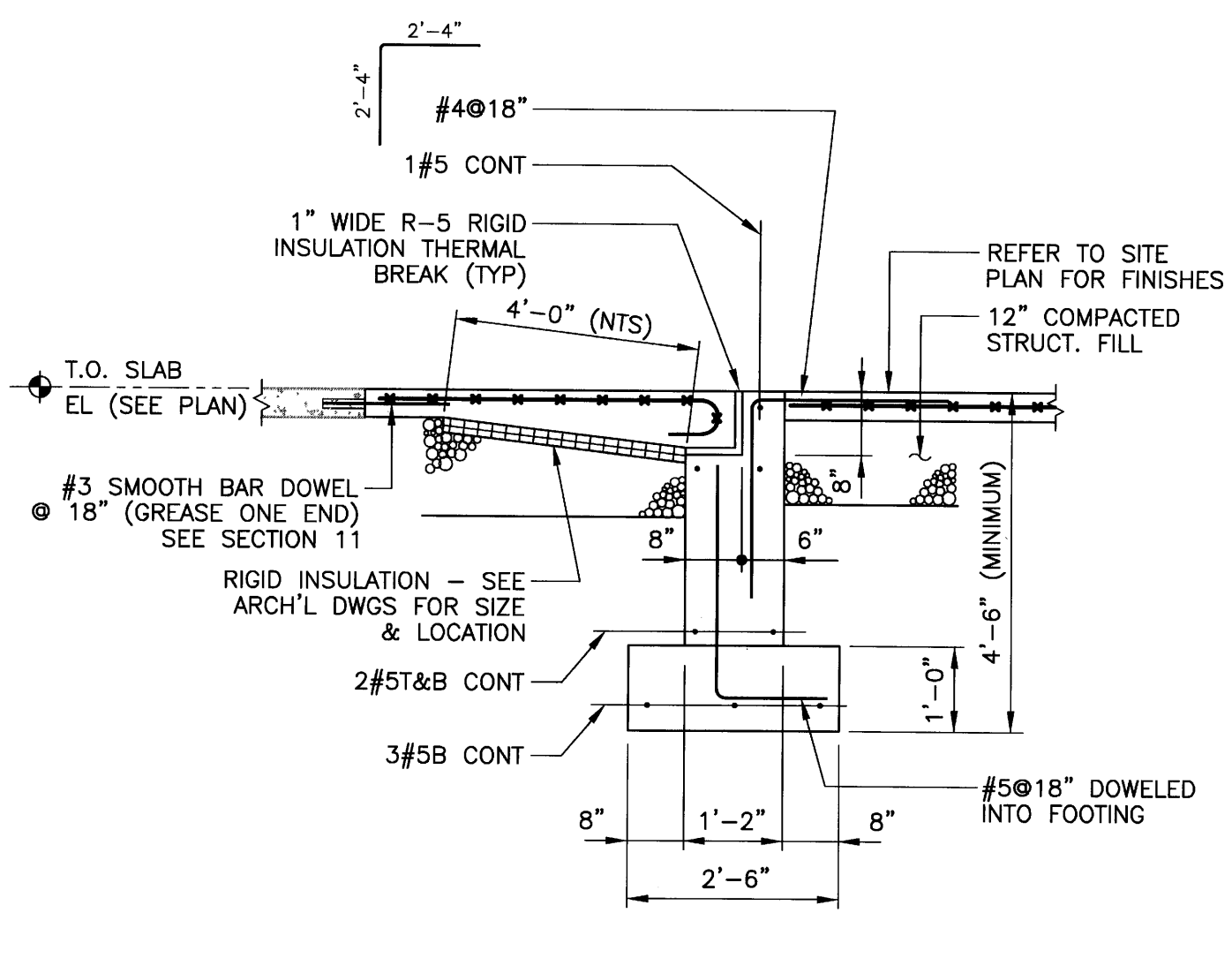

**8 SECTION**  
 S1 SCALE: 1/2"=1'-0"

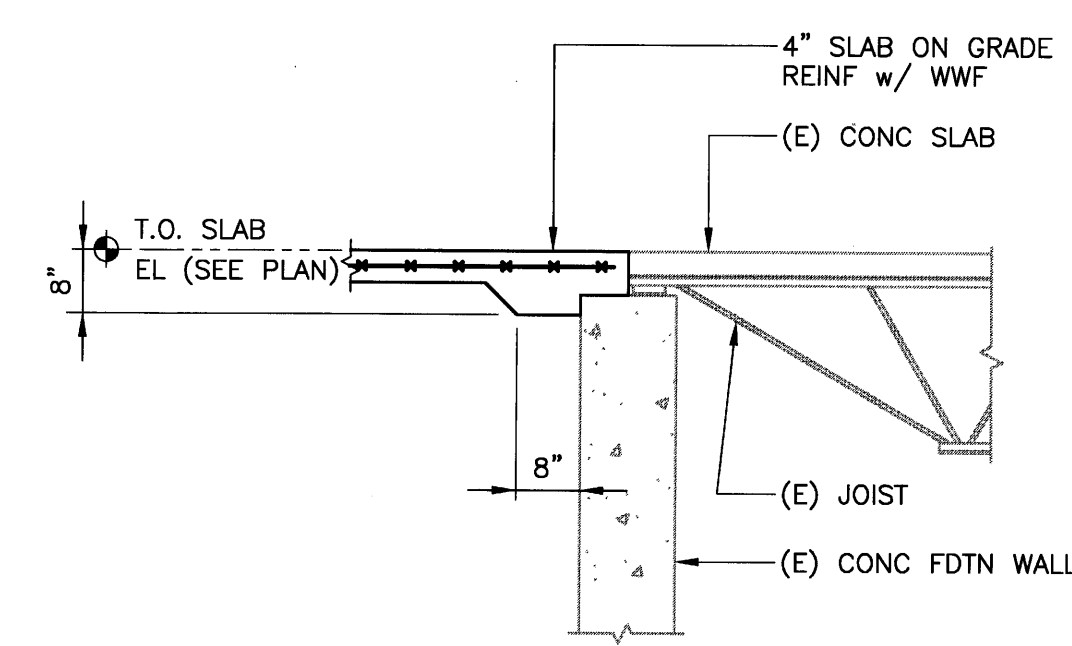

**9 SECTION**  
 S1 SCALE: 1/2"=1'-0"

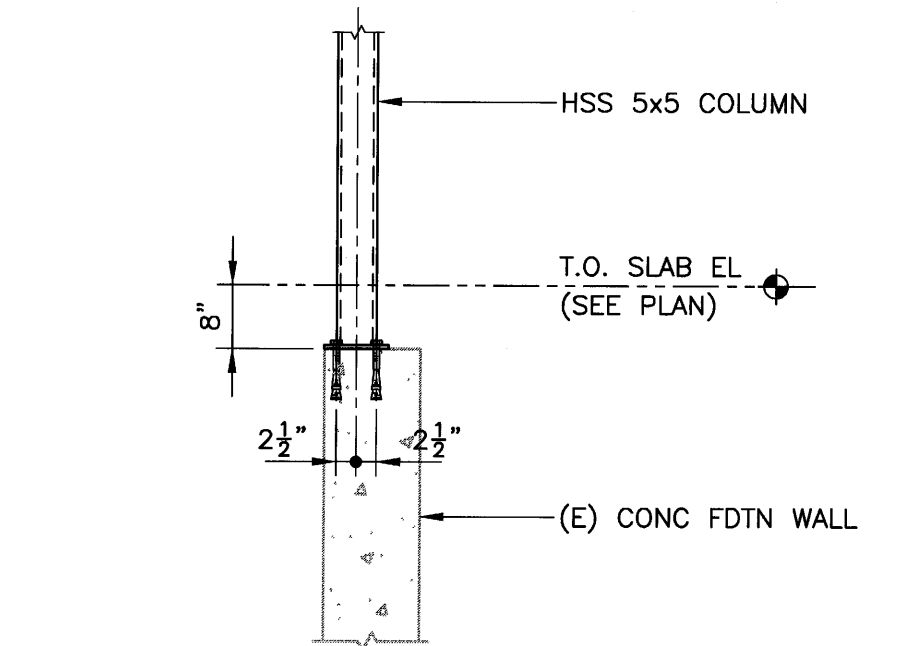

**10 SECTION**  
 S1 SCALE: 1/2"=1'-0"

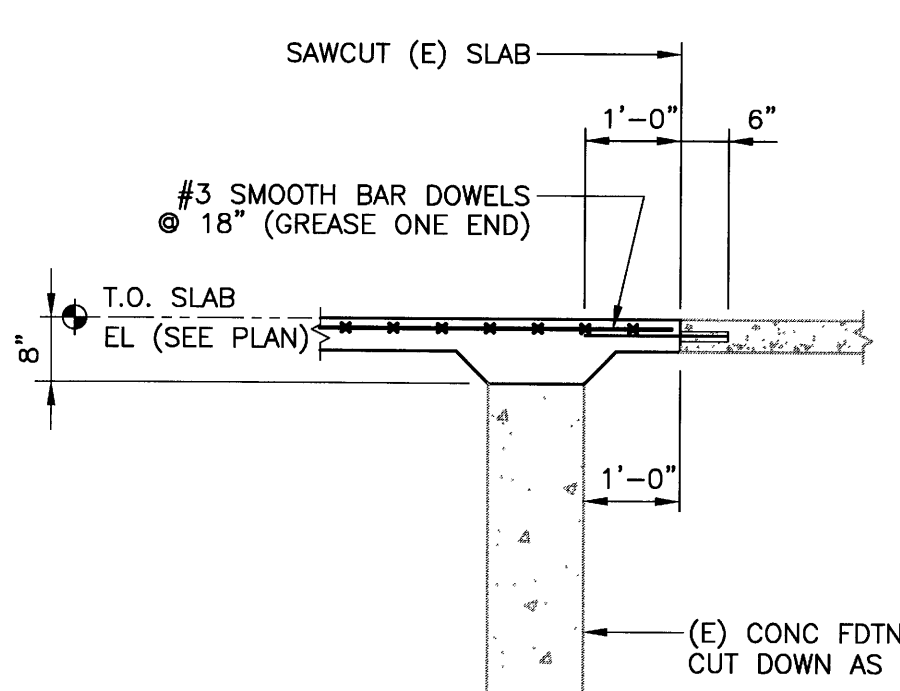

**11 SECTION**  
 S1 SCALE: 1/2"=1'-0"

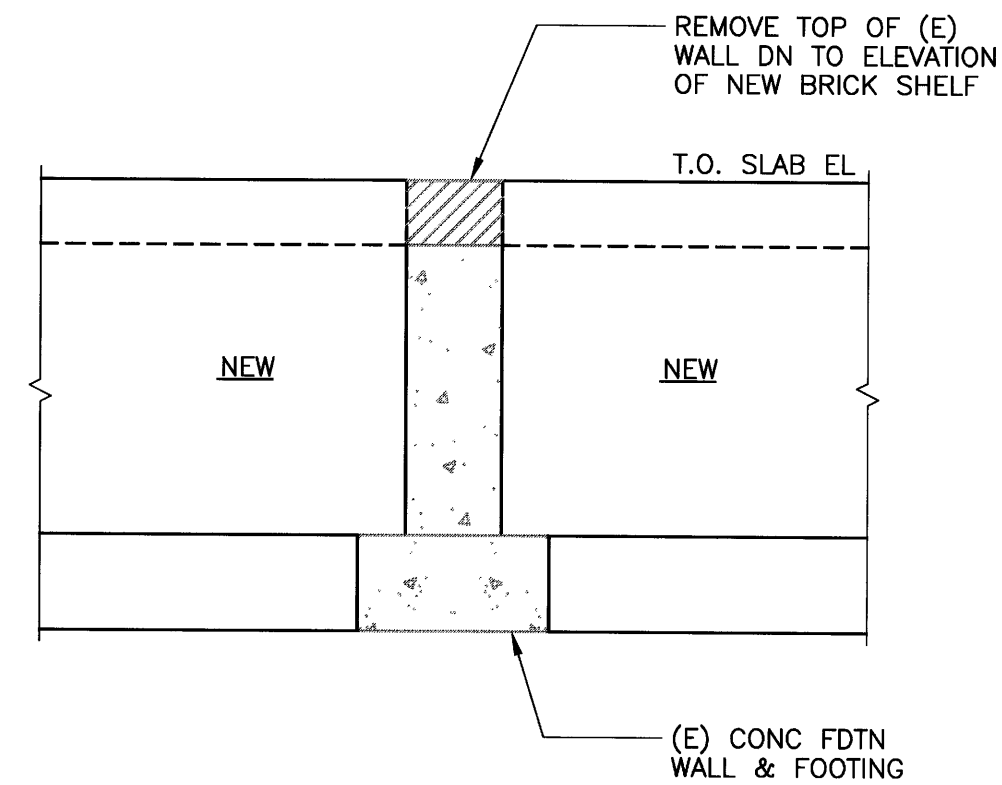

**12 SECTION**  
 S1 SCALE: 1/2"=1'-0"

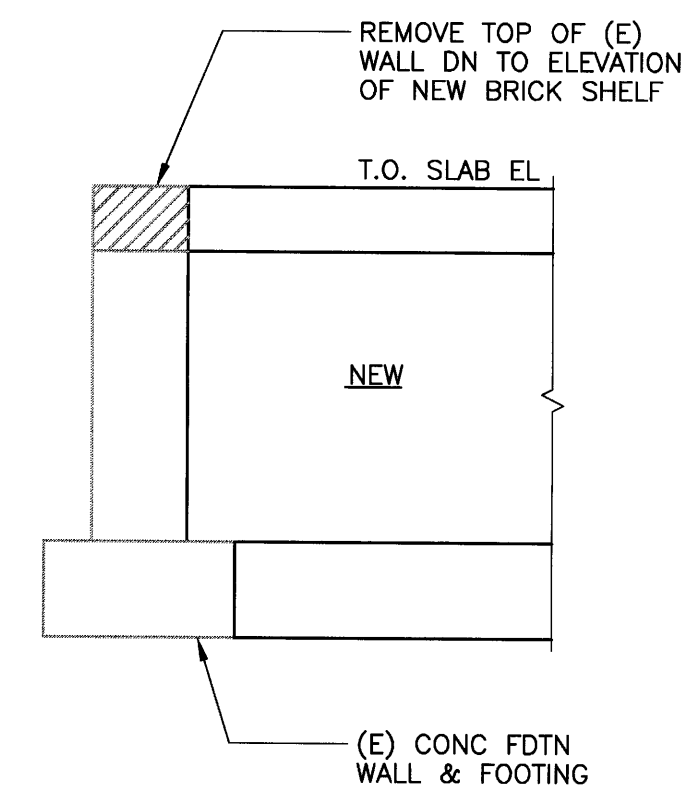

**13 SECTION**  
 S1 SCALE: 1/2"=1'-0"

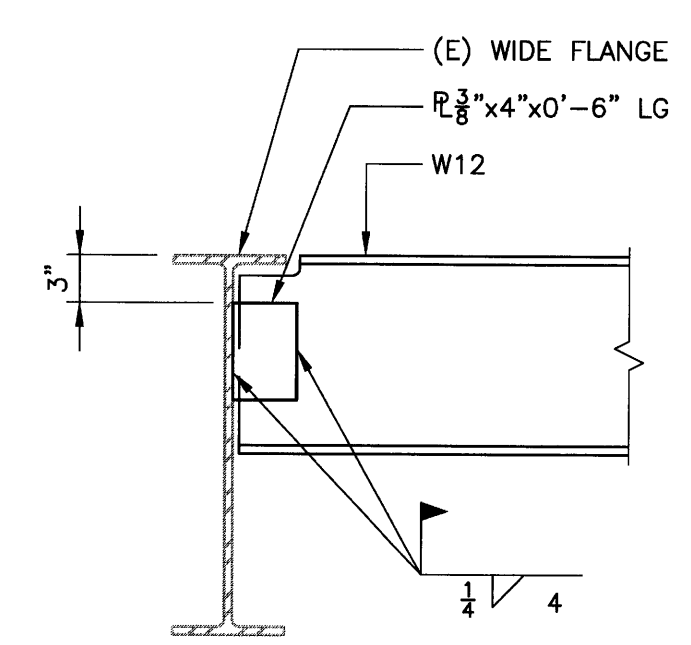

**14 SECTION**  
 S1 SCALE: 1"=1'-0"

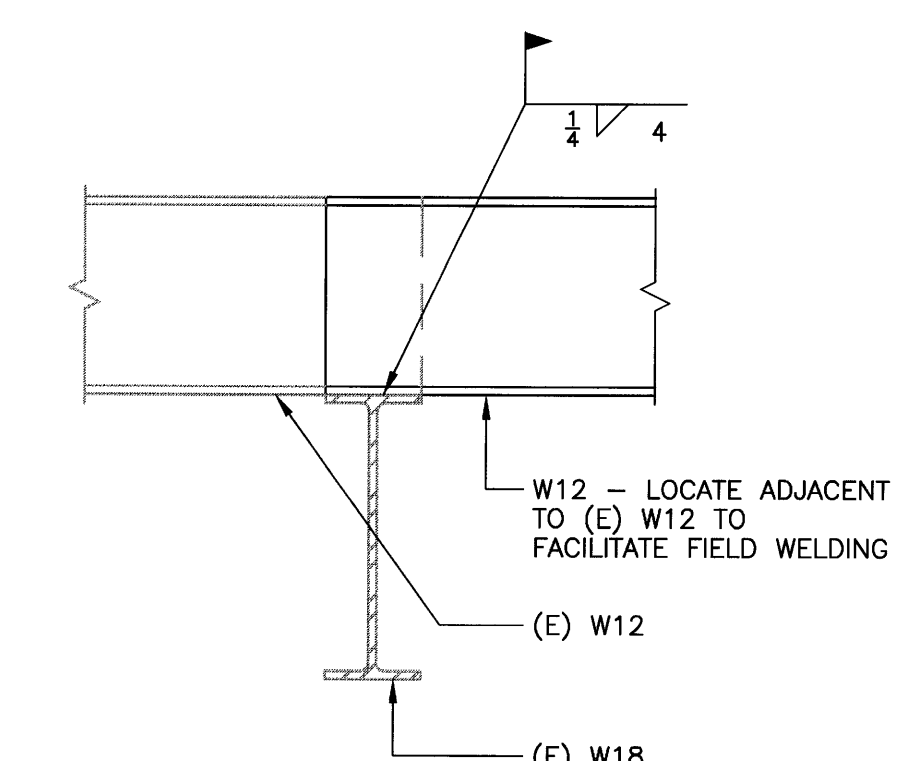

**15 SECTION**  
 S1 SCALE: 1"=1'-0"

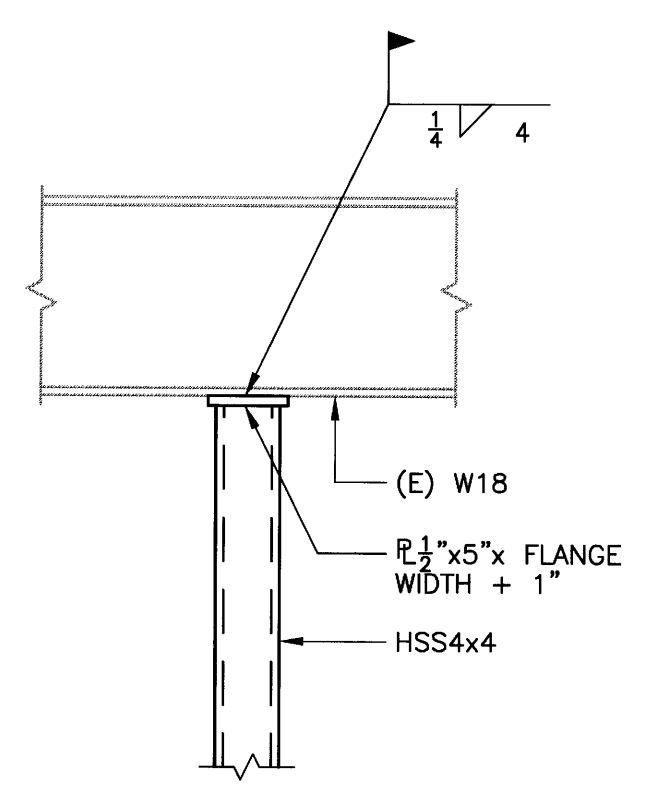

**16 SECTION**  
 S1 SCALE: 1"=1'-0"

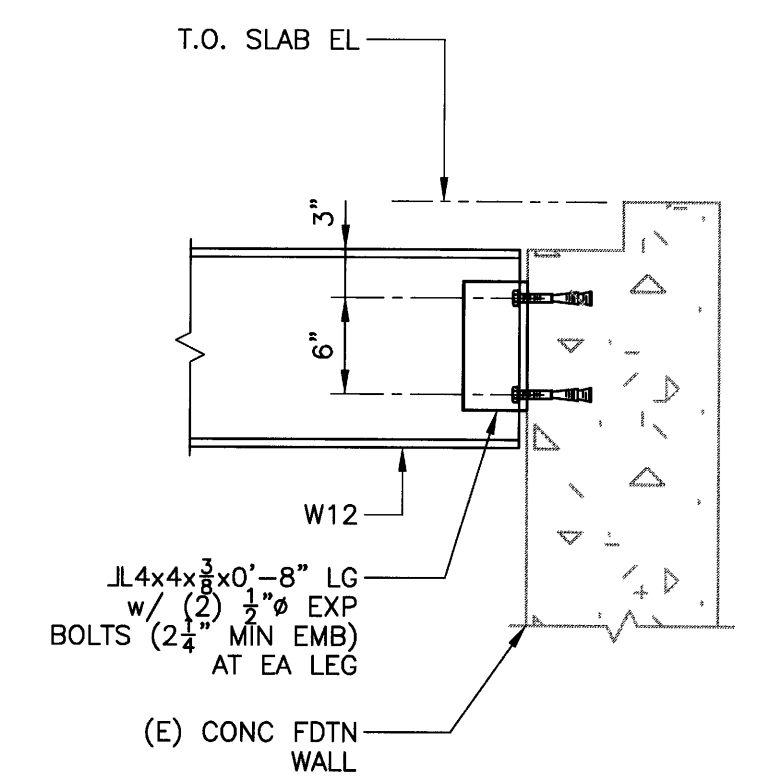

**17 SECTION**  
 S1 SCALE: 1"=1'-0"

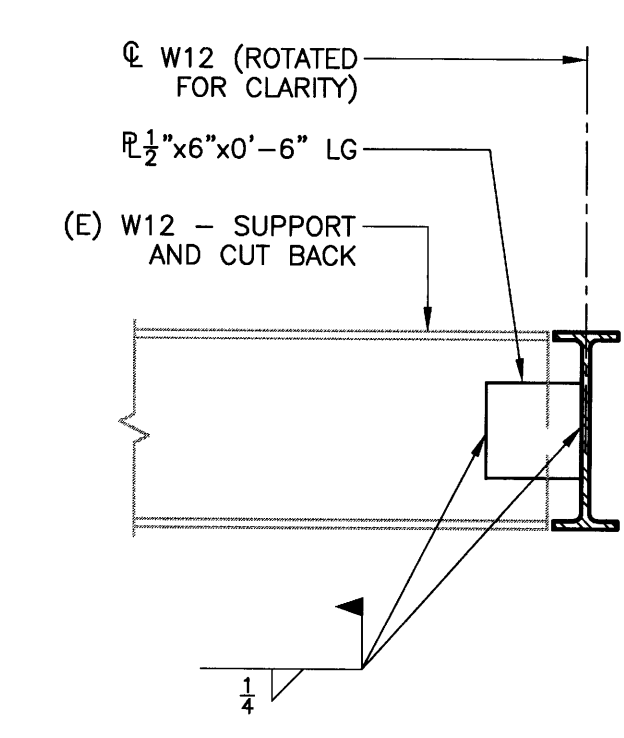

**18 SECTION**  
 S1 SCALE: 1"=1'-0"

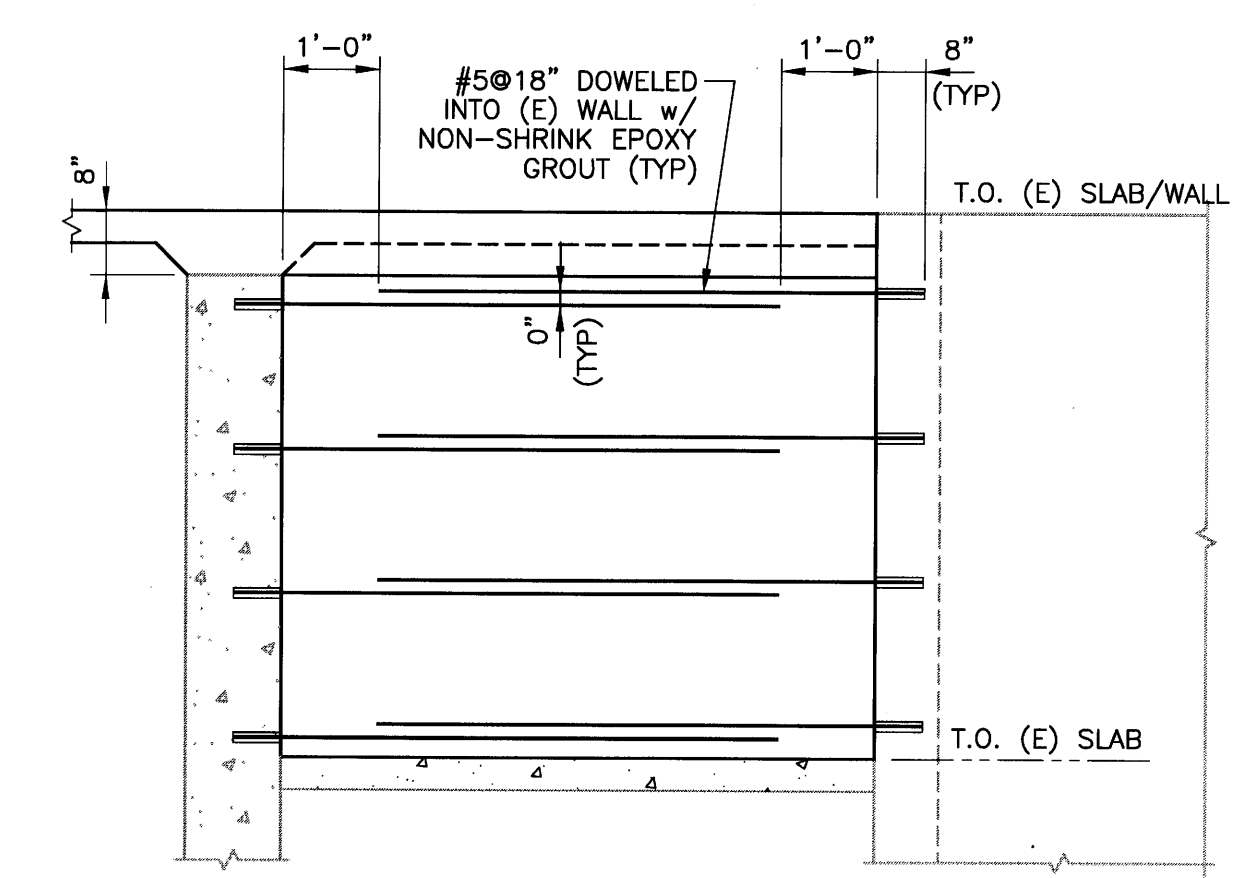

**19 SECTION**  
 S1 SCALE: 1/2"=1'-0"

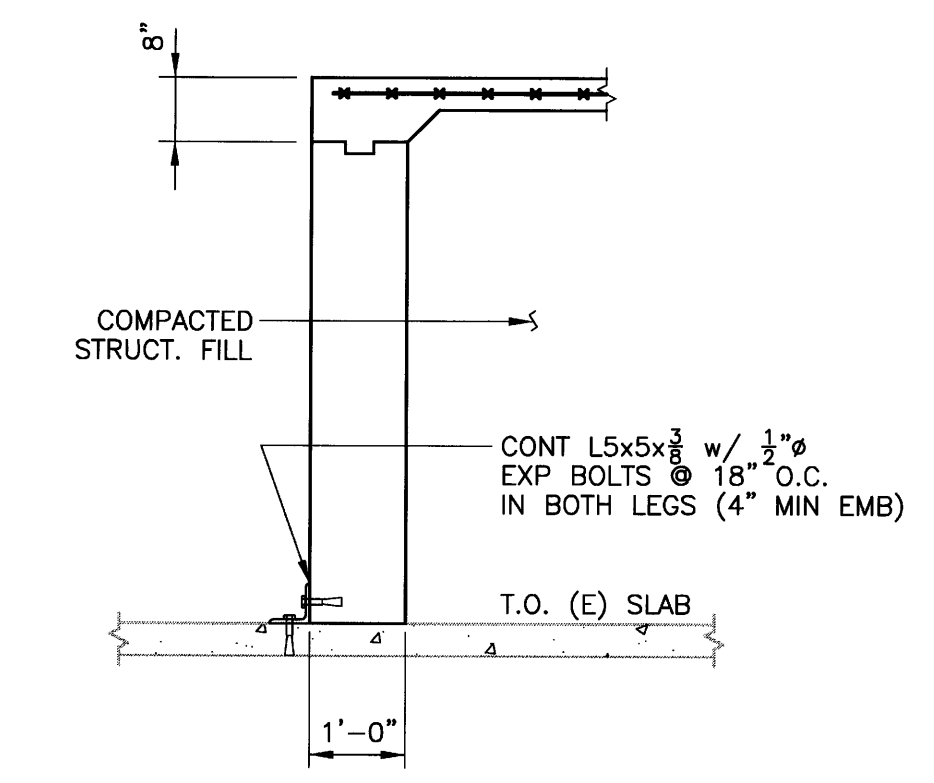

**20 SECTION**  
 S1 SCALE: 1/2"=1'-0"

NO.	DATE	BY	DESCRIPTION	CONST

REVISIONS  
 CERTIFICATION AND SEAL

I HEREBY CERTIFY THAT THIS PLAN AND SPECIFICATION WAS PREPARED BY ME OR UNDER MY DIRECT SUPERVISION AND THAT I AM A DULY REGISTERED ARCHITECT OR ENGINEER UNDER THE LAWS OF THE STATE OF MAINE AS SIGNIFIED BY MY HAND AND SEAL.

FISCAL 2007 CRITERIA - STORE # 12325  
 WALGREENS  
 616 FOREST AVENUE  
 PORTLAND, MAINE

DRAWING TITLE  
**SECTIONS and DETAILS**

CADD PLOT:	SCALE: AS NOTED	DRAWING NO.
VOID PLOT:	DRAWN BY: RGC	<b>S4</b>
RELEASED TO CONSTRUCTION	DATE: 12/10/08	
	REVIEWED BY: DWD	