

**HANDICAP PARKING PLAN DETAIL**

SCALE: 1" = 10'

PER ADA:

2% MAXIMUM ACCESSIBLE PARKING ZONE @ HCP PARKING SPACES AND PATH. GRADING SLOPE NOT TO EXCEED 2% IN ANY DIRECTION. (1.5% PREFERENCE BY WALGREENS)

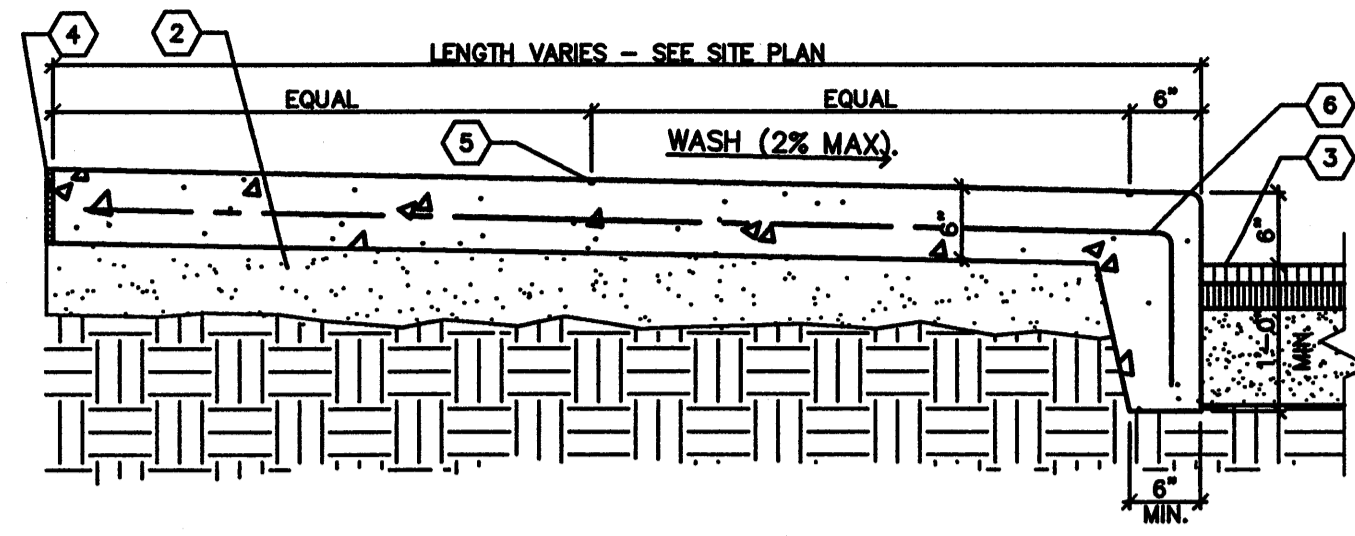
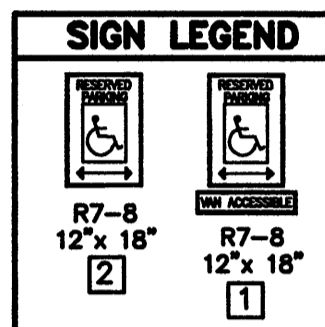

- KEYED NOTES**
- 1) N/A
  - 2) 12" MDOT 703.06 AGGREGATE TYPE A
  - 3) PAVEMENT.
  - 4) COMPRESSIBLE FILLER (3/4" MAXIMUM). CUT BACK AND PROVIDE SEALANT, TYPICAL, AT ALL JOINTS WITH FILLER.
  - 5) 1/4" TOOLED JOINT
  - 6) 6" X 6" #10 W.W.F.

**TYPICAL BUILDING PERIMETER SIDEWALK**

NOT TO SCALE

**THICKNESS OF LAYERS**

STANDARD	HEAVY DUTY	LAYERS
1.50"	1.50"	SURFACE COURSE MDOT 703.09 HOT MIX ASPHALT 3/8" (9.5 mm)
2.00"	2.00"	BINDER COURSE MDOT 703.09 HOT MIX ASPHALT 3/4" (19.0 mm)
6"	8"	AGGREGATE BASE GRAVEL MDOT 703.06 TYPE A
12"	15"	AGGREGATE SUBBASE GRAVEL MDOT 703.06 TYPE D

**BITUMINOUS PAVEMENT SECTION**

NOT TO SCALE

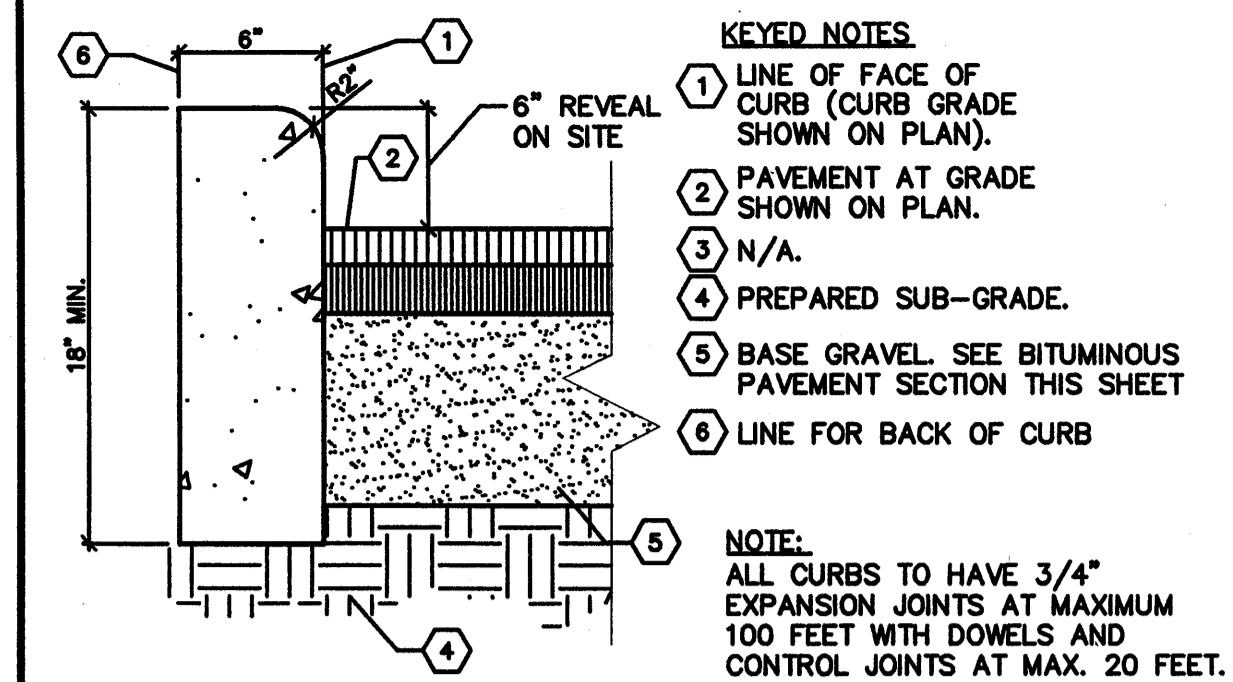

**CONCRETE CURB**

NOT TO SCALE

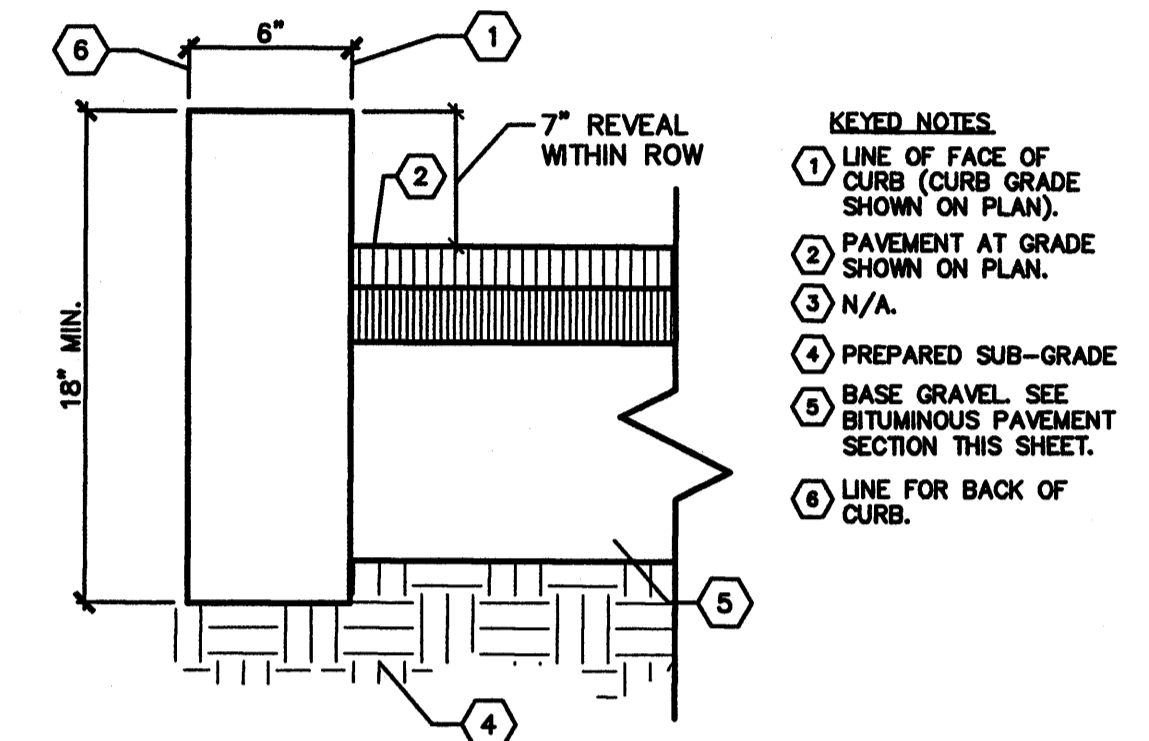

**VERTICAL GRANITE CURB**

NOT TO SCALE

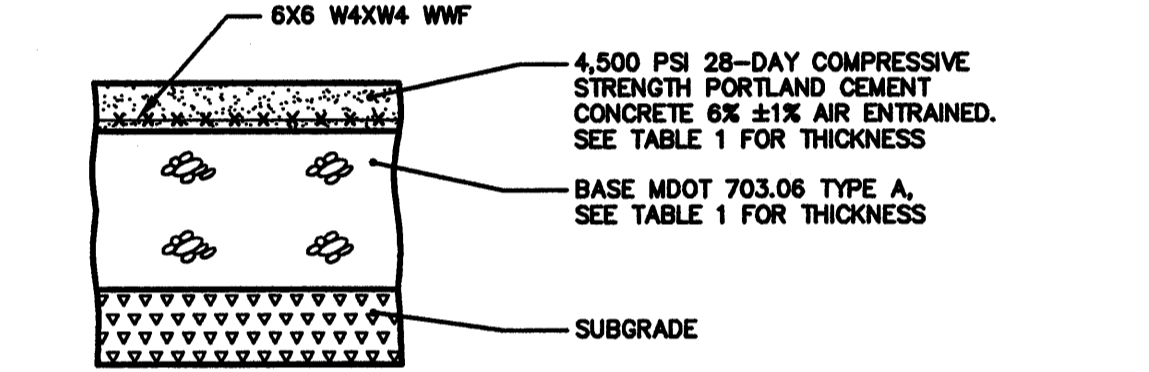

**TABLE 1**

DESCRIPTION	SLAB	MDOT 703.06 AGGREGATE TYPE A
ALL SLABS	6"	12"

- NOTE:**
1. COMPACT SUBGRADE TO 95% MAXIMUM DRY DENSITY IN ACCORDANCE WITH ASTM D-1557.
  2. SITE CONTRACTOR SHALL BE RESPONSIBLE FOR SUBGRADE PREPARATION AND PLACEMENT/COMPOSITION OF ALL AGGREGATE BASE/SUBBASE COURSE GRAVELS FOR PORTLAND CEMENT CONCRETE SURFACES IN CONTACT WITH BUILDINGS.

**HEAVY DUTY PORTLAND CEMENT CONCRETE PAVEMENT SECTION**

NOT TO SCALE

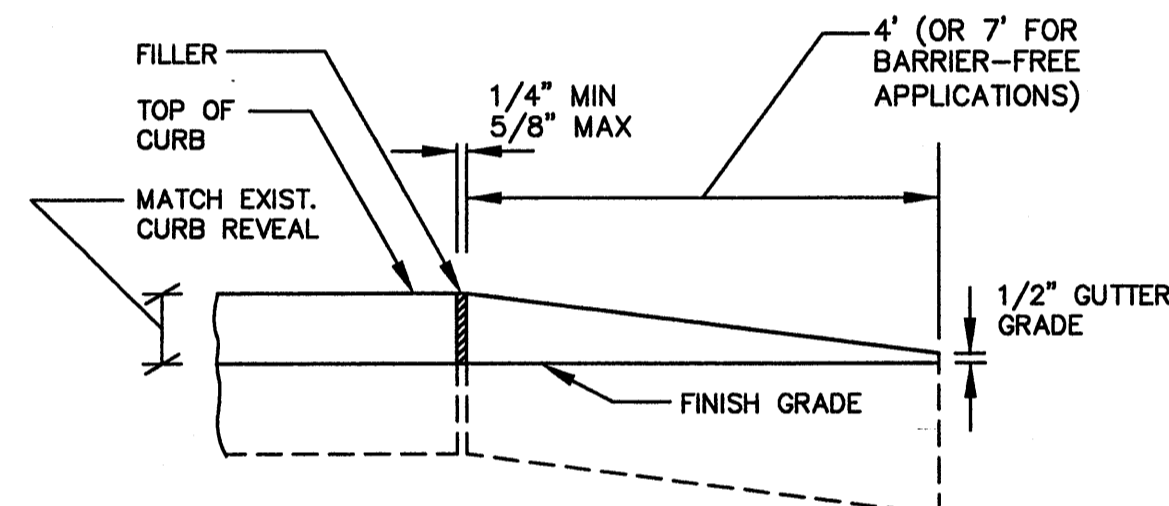

**TYPICAL TIPDOWN CURB INSTALLATION**

NOT TO SCALE

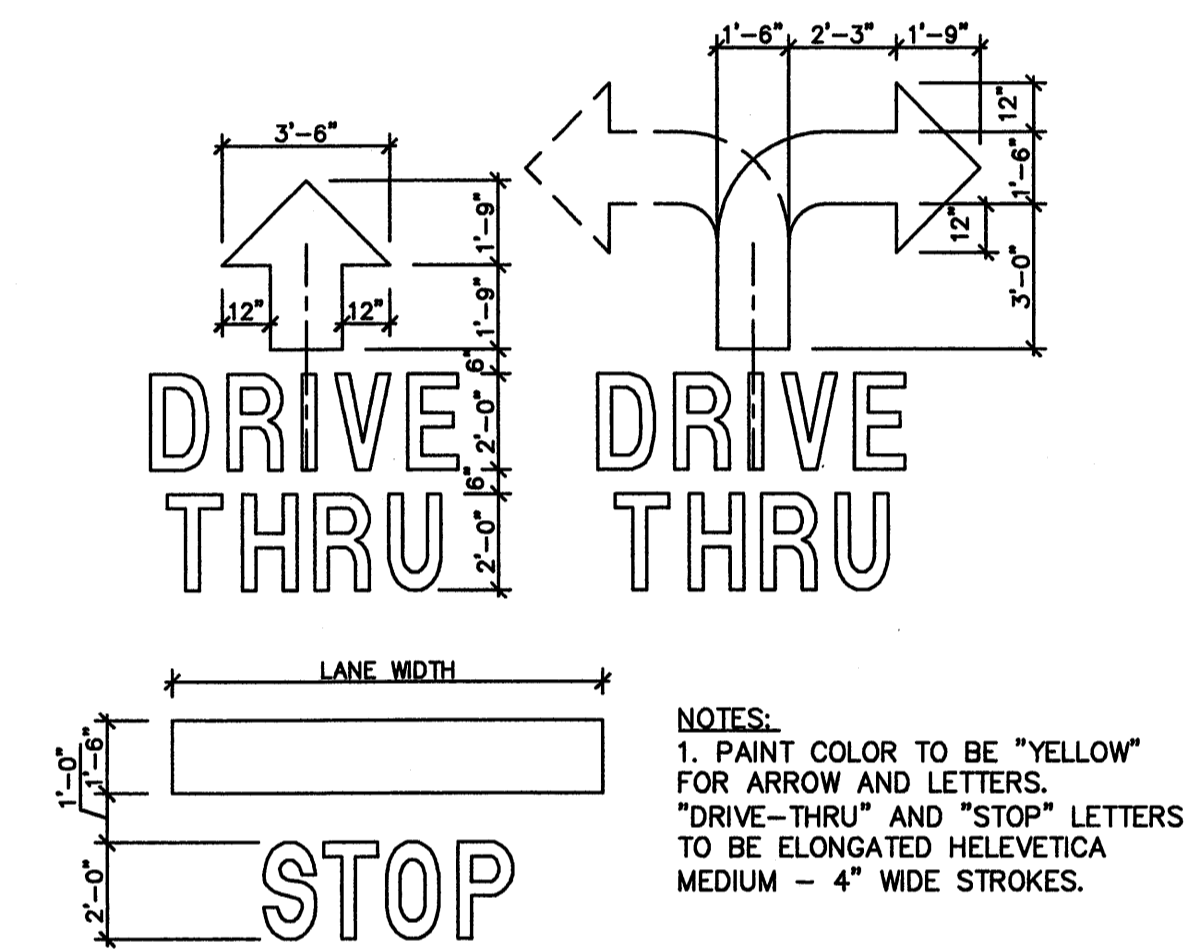

**PAVEMENT PAINTING**

NOT TO SCALE

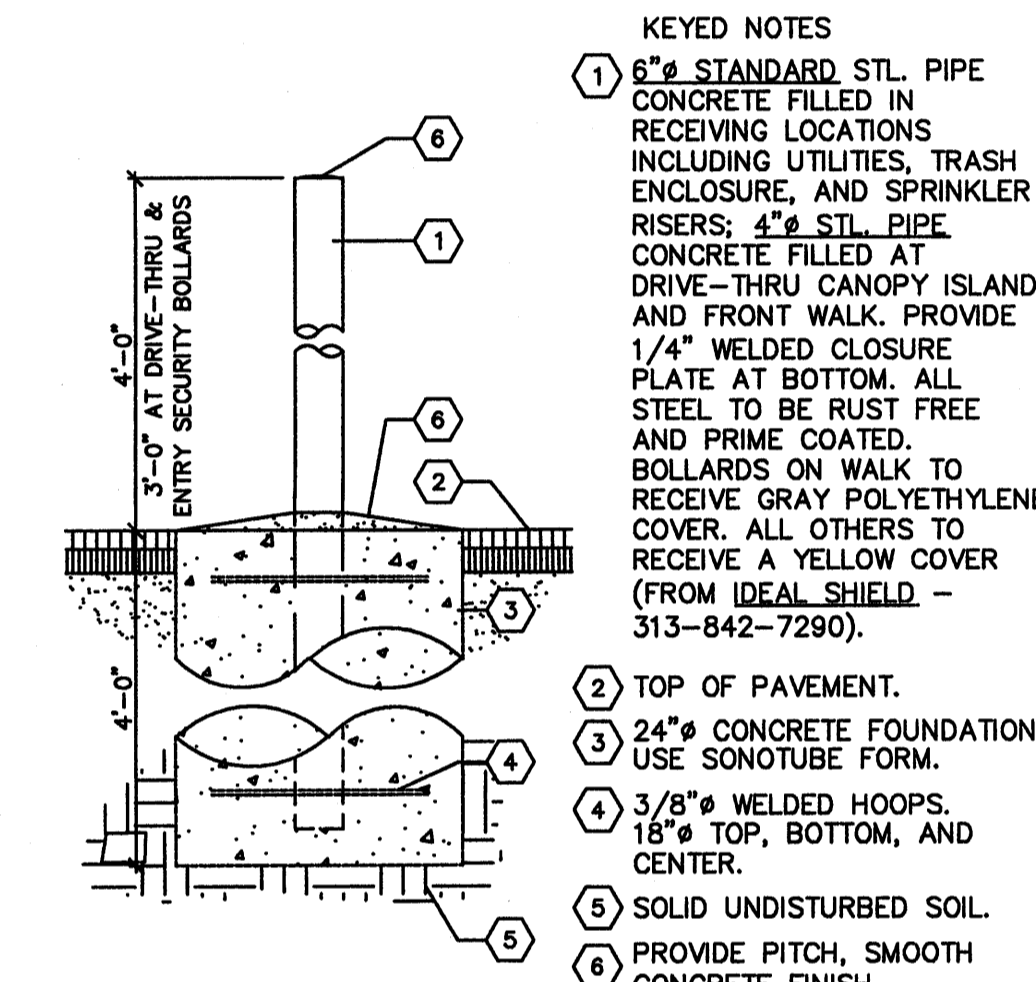

**PIPE BOLLARD**

NOT TO SCALE

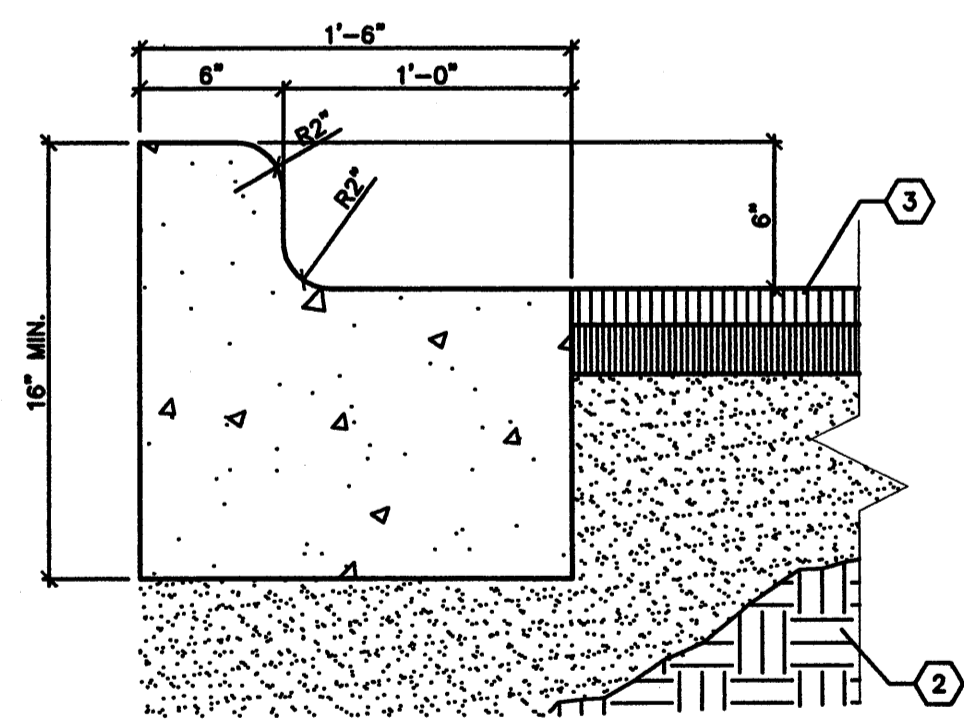

- KEYED NOTES**
- 1) N/A
  - 2) PREPARED SUB-GRADE.
  - 3) PAVEMENT.
- NOTE:** ALL CURBS TO HAVE 1/4" EXPANSION JOINTS AT MAXIMUM 100 FEET WITH DOWELS AND CONTROL JOINTS AT MAX. 20 FEET.

**COMBINED CURB & GUTTER**

NOT TO SCALE

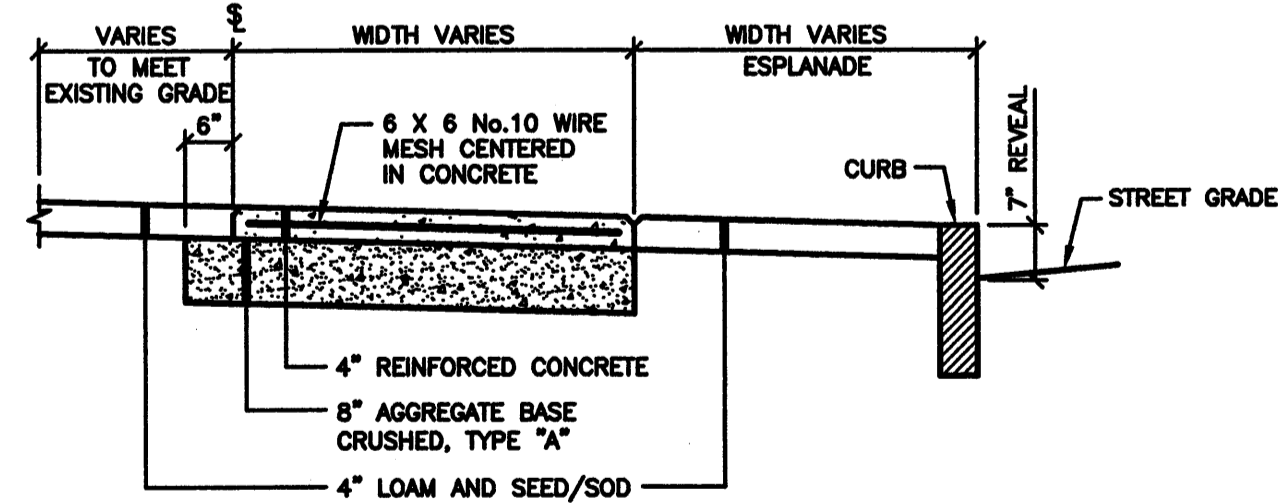

**SECTION AT SIDEWALK**

NOT TO SCALE

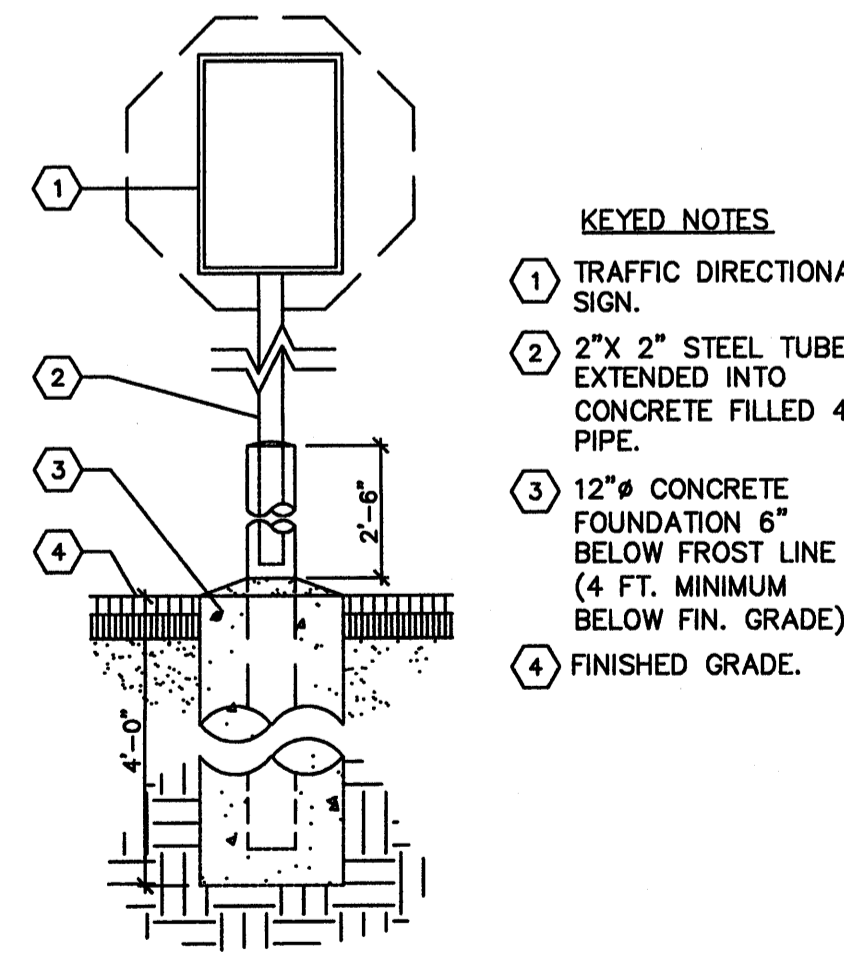

**TRAFFIC DIRECTIONAL SIGN**

NOT TO SCALE (FREE-STANDING)

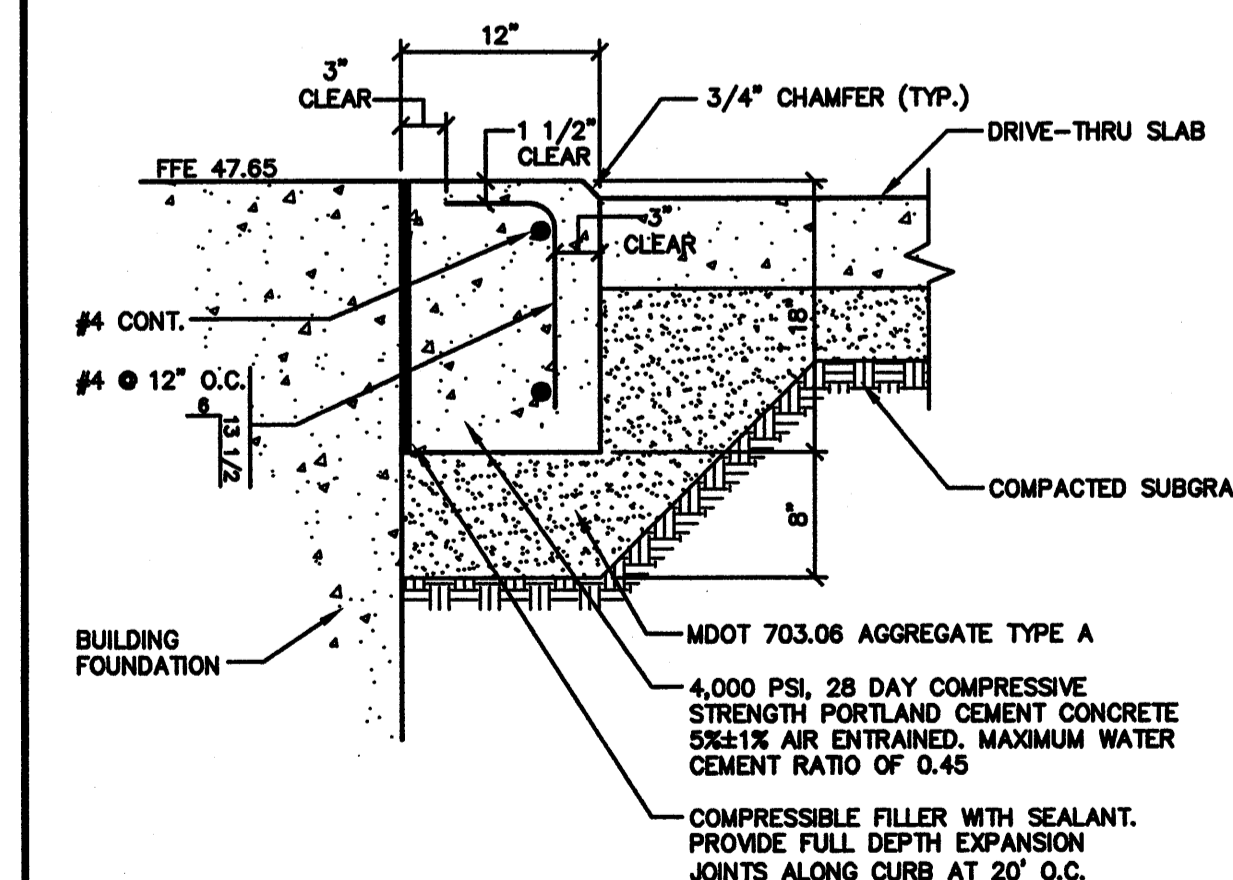

**CONCRETE CURB AT DRIVE-THRU**

NOT TO SCALE

CONSULTANT PROJECT NO. 1348  
PROJECT TYPE

DRAWINGS/SPECIFICATIONS BY:  
 WALGREENS  
 LANDLORD'S CONSULTANT

ALL CONSTRUCTION WORK, UNLESS NOTED OTHERWISE, BY:  
 WALGREENS' CONTRACTOR  
 LANDLORD'S CONTRACTOR (TURNKEY CONSTRUCTION)

STORE	BUILDING
NEW . . . . . <input checked="" type="checkbox"/>	NEW . . . . . <input type="checkbox"/>
REMODELING . . . . . <input type="checkbox"/>	EXISTING . . . . . <input checked="" type="checkbox"/>
RELOCATION . . . . . <input type="checkbox"/>	NEW SHELL ONLY . . . . . <input type="checkbox"/>
OTHERS . . . . . <input type="checkbox"/>	

NO.	DATE	BY	DESCRIPTION	CONST
A	12/11/08	MPM	ISSUED FOR CONSTRUCTION	
2	04/16/08	MPM	RESPONSE TO CITY COMMENTS	
1	03/21/08	MPM	RESPONSE TO COMMENTS	

**REVISIONS**

**CERTIFICATION AND SEAL**

I HEREBY CERTIFY THAT THIS PLAN AND SPECIFICATION WAS PREPARED BY ME OR UNDER MY DIRECT SUPERVISION AND THAT I AM A DULY REGISTERED ARCHITECT OR ENGINEER UNDER THE LAWS OF THE STATE OF MAINE AS SIGNIFIED BY MY HAND AND SEAL.

STORE NUMBER 12325  
PROJECT NAME  
**WALGREENS - STORE #12325**  
(SWC) FOREST & REVERE  
PORTLAND, MAINE

DRAWING TITLE  
SITE DETAILS - 1

CADD PLOT: SCALE: DRAWING NO. \_\_\_\_\_  
VOID PLOT: DRAWN BY: JBC  
SUPERSEDES PLAN DATED: DATE: 12/07 REVIEWED BY: MPM OF \_ DWGS.