

DISPLAY THIS CARD ON PRINCIPAL FRONTAGE OF WORK



CITY OF PORTLAND

BUILDING PERMIT

This is to certify that MICHAEL J TRUSTEE FUREY

Located At 34 REVERE ST

Job ID: 2012-01-2998-ALTR

CBL: 125- E-002-001

has permission to New door extend Deck

provided that the person or persons, firm or corporation accepting this permit shall comply with all of the provisions of the Statues of Maine and of the Ordinances of the City of Portland regulating the construction, maintenance and use of the buildings and structures, and of the application on file in the department.

Notification of inspection and written permission procured before this building or part thereof is lathed or otherwise closed-in. 48 HOUR NOTICE IS REQUIRED.

A final inspection must be completed by owner before this building or part thereof is occupied. If a certificate of occupancy is required, it must be

Fire Prevention Officer

Code Enforcement Officer / Plan Reviewer

THIS CARD MUST BE POSTED ON THE STREET SIDE OF THE PROPERTY
PENALTY FOR REMOVING THIS CARD

City of Portland, Maine - Building or Use Permit Application

389 Congress Street, 04101 Tel: (207) 874-8703, FAX: (207) 8716

| | | | |
|---|--|---|--|
| Job No: 2012-01-2998-ALTR | Date Applied: 12/29/2011 | CBL: 125- E-002-001 | |
| Location of Construction: 34 REVERE ST | Owner Name: MICHAEL FUREY TRUSTEE | Owner Address: 6 ARLINGTON PL PORTLAND, ME 04101 | Phone: 207-772-2295 |
| Business Name: | Contractor Name: Larry Palozzi | Contractor Address: 33 Meadow LN CUMBERLAND CTR ME 04021 | Phone: (207) 232-0290 |
| Lessee/Buyer's Name: | Phone: | Permit Type: BLDG - Building | Zone: R-5 |
| Past Use: Two family | Proposed Use: Same - Two family - move door & expand entry deck | Cost of Work: 2000.00 | CEO District: |
| | | Fire Dept: Signature: <i>[Signature]</i> | Inspection: Use Group: <i>R-3</i> Type: <i>5B</i> Signature: <i>[Signature]</i> |
| Proposed Project Description: New door & extend Deck | | Pedestrian Activities District (P.A.D.) | |
| Permit Taken By: | Zoning Approval | | |

| Special Zone or Reviews | Zoning Appeal | Historic Preservation |
|---|---|---|
| <input type="checkbox"/> Shoreland <input type="checkbox"/> Wetlands <input type="checkbox"/> Flood Zone <input type="checkbox"/> Subdivision <input type="checkbox"/> Site Plan <input type="checkbox"/> Maj <input type="checkbox"/> Min <input type="checkbox"/> MM Date: <i>OK w/ conditions</i> <i>1/5/11 ABM</i> | <input type="checkbox"/> Variance <input type="checkbox"/> Miscellaneous <input type="checkbox"/> Conditional Use <input type="checkbox"/> Interpretation <input type="checkbox"/> Approved <input type="checkbox"/> Denied Date: | <input checked="" type="checkbox"/> Not in Dist or Landmark <input type="checkbox"/> Does not Require Review <input type="checkbox"/> Requires Review <input type="checkbox"/> Approved <input type="checkbox"/> Approved w/Conditions <input type="checkbox"/> Denied Date: <i>ABM</i> |

CERTIFICATION

I hereby certify that I am the owner of record of the named property, or that the proposed work is authorized by the owner of record and that I have been authorized by the owner to make this application as his authorized agent and I agree to conform to all applicable laws of this jurisdiction. In addition, if a permit for work described in the application is issued, I certify that the code official's authorized representative shall have the authority to enter all areas covered by such permit at any reasonable hour to enforce the provision of the code(s) applicable to such permit.

| | | | |
|---|---------|------|-------|
| SIGNATURE OF APPLICANT | ADDRESS | DATE | PHONE |
| RESPONSIBLE PERSON IN CHARGE OF WORK, TITLE | | DATE | PHONE |



General Building Permit Application

If you or the property owner owes real estate or personal property taxes or user charges on any property within the City, payment arrangements must be made before permits of any kind are accepted.

| | | |
|---|--|--|
| Location/Address of Construction: <u>34 Revere St</u> | | |
| Total Square Footage of Proposed Structure/Area <u>420 ±</u> | Square Footage of Lot <u>5885 ±</u> | Number of Stories <u>2</u> |
| Tax Assessor's Chart, Block & Lot Chart# <u>125</u> Block# <u>2</u> Lot# <u>2</u> | Applicant *must be owner, Lessee or Buyer* Name <u>MICHAEL FUREY</u> Address <u>6 ARLINGTON PLACE</u> City, State & Zip <u>PORTLAND, ME 04102</u> | Telephone: <u>772-2295</u> |
| Lessee/DBA (If Applicable) | Owner (if different from Applicant) Name Address City, State & Zip | Cost Of Work: \$ <u>1,200</u> C of O Fee: \$ _____ Total Fee: \$ <u>40</u> |
| Current legal use (i.e. single family) <u>2 FAMILY</u> Number of Residential Units <u>2</u> If vacant, what was the previous use? <u>RENTAL</u> Proposed Specific use: <u>RENTAL</u> Is property part of a subdivision? <u>NO</u> If yes, please name _____ Project description: <u>NEW DOOR + EXTEND DECK-</u> | | |
| Contractor's name: <u>LARRY PALLOZZI</u> Address: <u>33 MEADOW LN</u> City, State & Zip: <u>CUMBERLAND, ME. 04021</u> Telephone: <u>232-0290</u> Who should we contact when the permit is ready: <u>LARRY</u> Telephone: _____ Mailing address: <u>SAME AS ABOVE</u> | | |

RECEIVED
DEC 29 2011
City of Portland Inspections
Department of Building Inspections
City of Portland Maine

Please submit all of the information outlined on the applicable Checklist. Failure to do so will result in the automatic denial of your permit.

In order to be sure the City fully understands the full scope of the project, the Planning and Development Department may request additional information prior to the issuance of a permit. For further information or to download copies of this form and other applications visit the Inspections Division on-line at www.portlandmaine.gov, or stop by the Inspections Division office, room 315 City Hall or call 874-8703.

I hereby certify that I am the Owner of record of the named property, or that the owner of record authorizes the proposed work and that I have been authorized by the owner to make this application as his/her authorized agent. I agree to conform to all applicable laws of this jurisdiction. In addition, if a permit for work described in this application is issued, I certify that the Code Official's authorized representative shall have the authority to enter all areas covered by this permit at any reasonable hour to enforce the provisions of the codes applicable to this permit.

Signature: [Signature] Date: 12/29/11
This is not a permit; you may not commence ANY work until the permit is issued

← 34 REVERE ST →

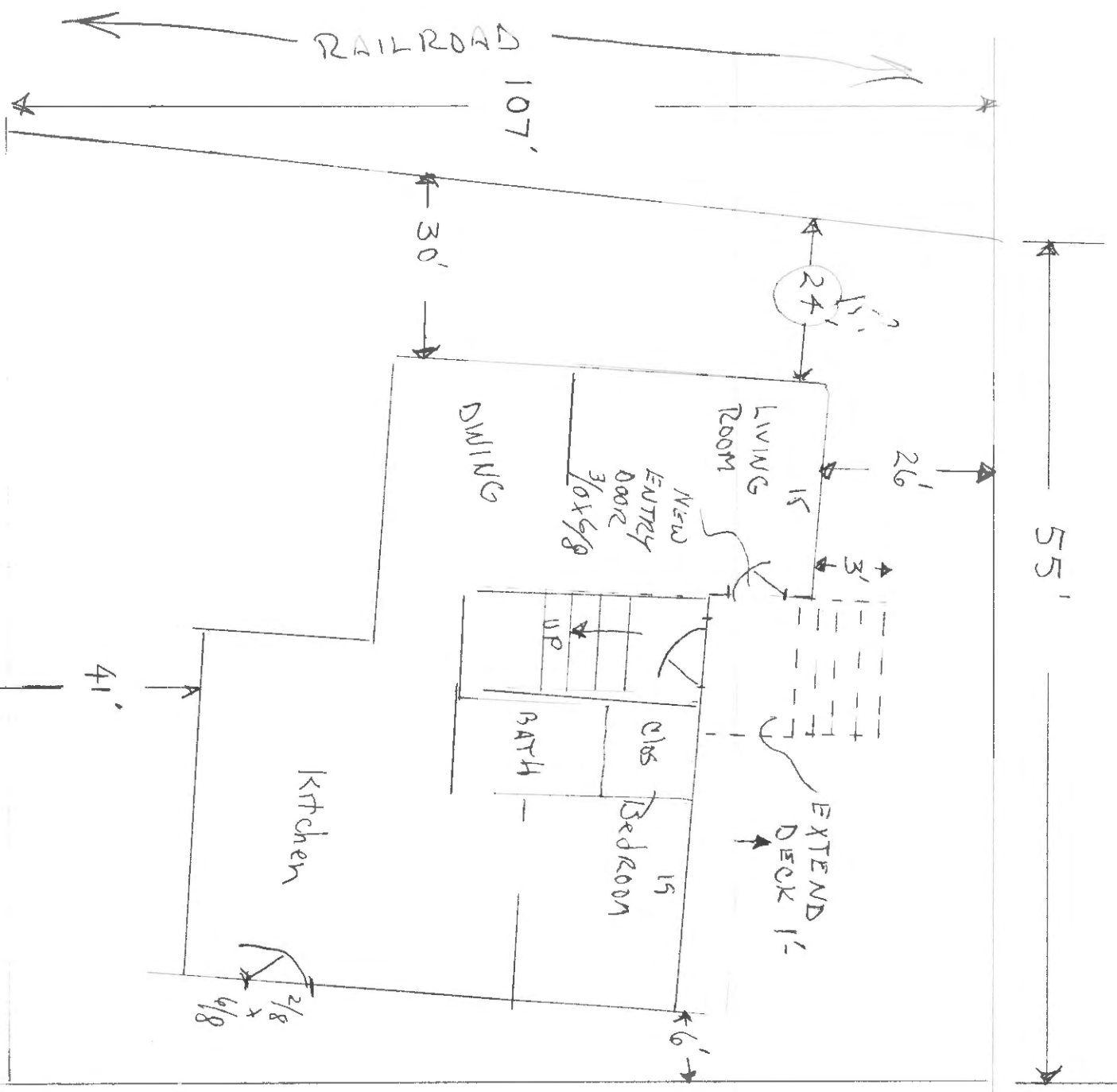

R₅
 lot size - 7315' φ
 front 20' - 23' (5 steps)
 or.

5' x 8' - 15' on front
 - 7' 13' on 14'

lot area 496 =
 29 2/8 φ

house = 1103 22
 space 4' x 15' =
 landing = 22

92' 1147' φ @ 10

LOCATION: 34 REVERE ST

NEW ENTRY DOOR
EXTEND DECK

OWNER: MICHAEL FUREY
6 ARLINGTON PLACE
PORTLAND, ME 04102
TEL 772-2295

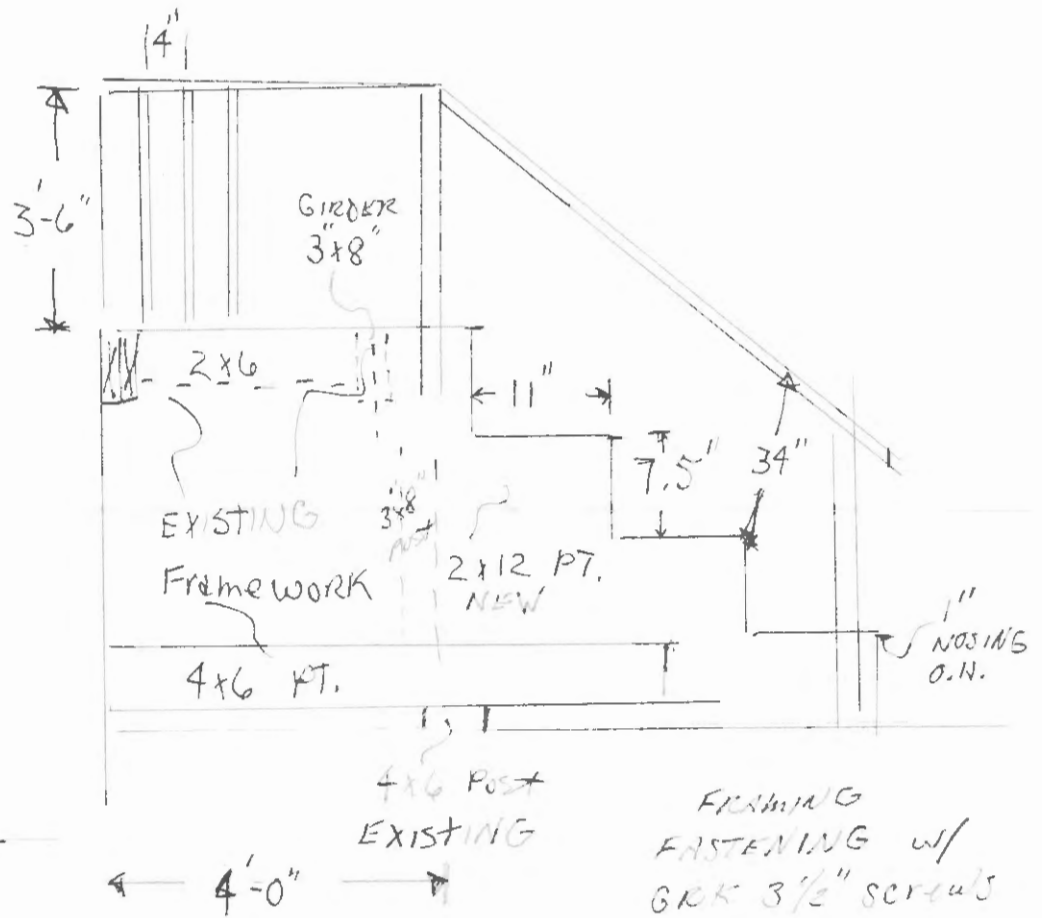
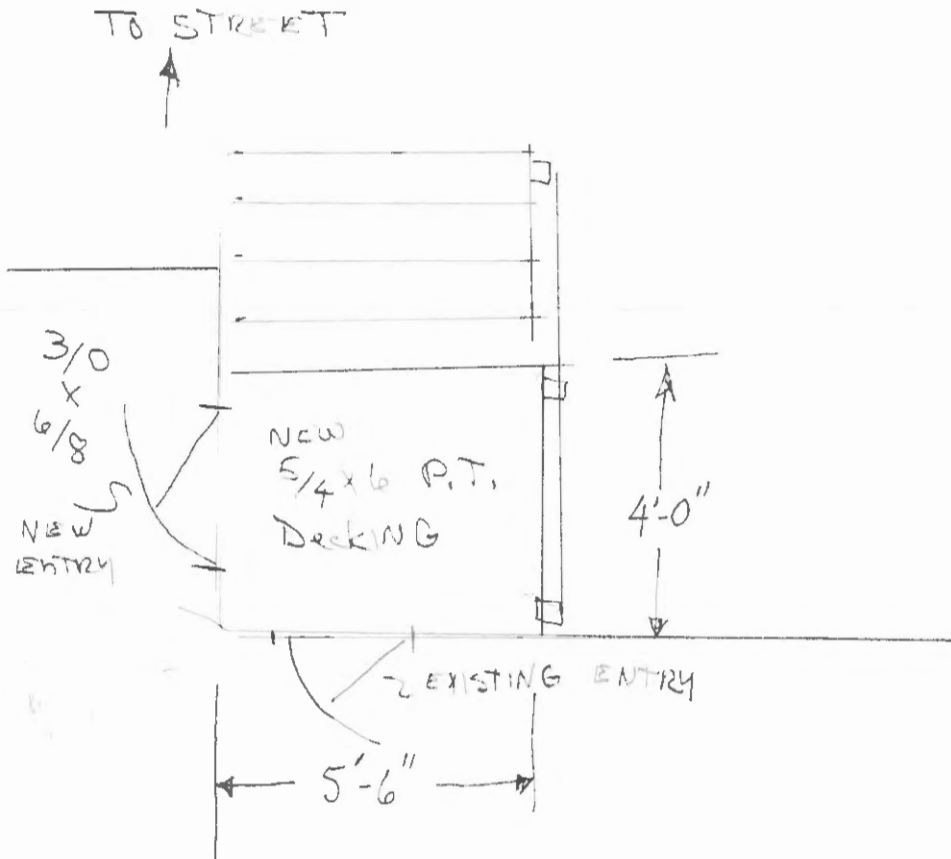

FRAMING
FASTENING w/
GRK 3 1/2" screws

Decking
FASTENING w/
GRK 2 1/2" screws