

DISPLAY THIS CARD ON PRINCIPAL FRONTAGE OF WORK
CITY OF PORTLAND

Please Read
Application And
Notes, If Any,
Attached

BUILDING INSPECTION

PERMIT

Permit Number: 070283

This is to certify that FLETCHER WENDALL M /Jeff Lacoursehas permission to Replace existing stairs at front of buildingAT 48 REVERE ST

CITY OF PORTLAND 124 1017001

PERMIT ISSUED

MAR 20 2007

provided that the person or persons, firm or corporation accepting this permit shall comply with all of the provisions of the Statutes of this State and of the Ordinances of the City of Portland regulating the construction, maintenance and use of buildings and structures, and of the application on file in this department.

Apply to Public Works for street line and grade if nature of work requires such information.

Notification of inspection must be given and when permission procured before this building or part thereof is leased or occupied. **FOUR HOUR NOTICE IS REQUIRED.**

A certificate of occupancy must be procured by owner before this building or part thereof is occupied.

OTHER REQUIRED APPROVALS

Fire Dept. _____

Health Dept. _____

Appeal Board _____

Other _____
Department Name

Thomas M. Mackley 3/28/07
Director - Building & Inspection Services

PENALTY FOR REMOVING THIS CARD

City of Portland, Maine - Building or Use Permit Application

389 Congress Street, 04101 Tel: (207) 874-8703, Fax: (207) 874-8716

Permit No: 07-0283	Issue Date:	CBL: 124 1017001
-----------------------	-------------	---------------------

Location of Construction: 48 REVERE ST	Owner Name: FLETCHER WENDALL M JR	Owner Address: 48 REVERE ST	Phone:
Business Name:	Contractor Name: Jeff Lacourse	Contractor Address: 7 Kings Court North Waterboro	Phone: 2076518422
Lessee/Buyer's Name	Phone:	Permit Type: Alterations - Dwellings	Zone: R5
Past Use: Single Family Home	Proposed Use: Single Family Home - Replace existing stairs at front of building	Permit Fee: \$40.00	Cost of Work: \$2,000.00
Proposed Project Description: Replace existing stairs at front of building		FIRE DEPT: <input type="checkbox"/> Approved <input type="checkbox"/> Denied	CEO District: 3
		INSPECTION: Use Group: R3 Type: SB IRC 2003 Signature: Jm 3/20/07	
		PEDESTRIAN ACTIVITIES DISTRICT (P.A.D.) Action: <input type="checkbox"/> Approved <input type="checkbox"/> Approved w/Conditions <input type="checkbox"/> Denied Signature: _____ Date: _____	

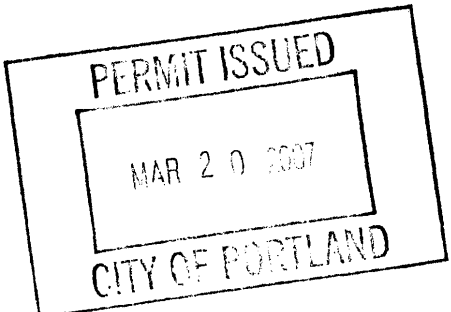
Permit Taken By: Idobson	Date Applied For: 03/20/2007	Zoning Approval		
<ol style="list-style-type: none"> This permit application does not preclude the Applicant(s) from meeting applicable State and Federal Rules. Building permits do not include plumbing, septic or electrical work. Building permits are void if work is not started within six (6) months of the date of issuance. False information may invalidate a building permit and stop all work.. 		Special Zone or Reviews <input type="checkbox"/> Shoreland <input type="checkbox"/> Wetland <input type="checkbox"/> Flood Zone <input type="checkbox"/> Subdivision <input type="checkbox"/> Site Plan Maj <input type="checkbox"/> Minor <input type="checkbox"/> MM <input type="checkbox"/> Date: 3/20/07 Jm	Zoning Appeal <input type="checkbox"/> Variance <input type="checkbox"/> Miscellaneous <input type="checkbox"/> Conditional Use <input type="checkbox"/> Interpretation <input type="checkbox"/> Approved <input type="checkbox"/> Denied Date: _____	Historic Preservation <input type="checkbox"/> Not in District or Landmark <input checked="" type="checkbox"/> Does Not Require Review <input type="checkbox"/> Requires Review <input type="checkbox"/> Approved <input type="checkbox"/> Approved w/Conditions <input type="checkbox"/> Denied Date: 3/20/07 Jm
				

CERTIFICATION

I hereby certify that I am the owner of record of the named property, or that the proposed work is authorized by the owner of record and that I have been authorized by the owner to make this application as his authorized agent and I agree to conform to all applicable laws of this jurisdiction. In addition, if a permit for work described in the application is issued, I certify that the code official's authorized representative shall have the authority to enter all areas covered by such permit at any reasonable hour to enforce the provision of the code(s) applicable to such permit.

SIGNATURE OF APPLICANT	ADDRESS	DATE	PHONE
RESPONSIBLE PERSON IN CHARGE OF WORK, TITLE		DATE	PHONE

City of Portland, Maine - Building or Use Permit

389 Congress Street, 04101 Tel: (207) 874-8703, Fax: (207) 874-8716

Permit No: 07-0283	Date Applied For: 03/20/2007	CBL: 124 I017001
------------------------------	--	----------------------------

Location of Construction: 48 REVERE ST	Owner Name: FLETCHER WENDALL M JR	Owner Address: 48 REVERE ST	Phone:
Business Name:	Contractor Name: Jeff Lacourse	Contractor Address: 7 Kings Court North Waterboro	Phone: (207) 651-8422
Lessee/Buyer's Name	Phone:	Permit Type: Alterations - Dwellings	

Proposed Use: Single Family Home - Replace existing stairs at front of building	Proposed Project Description: Replace existing stairs at front of building
---	--

Dept: Zoning **Status:** Approved **Reviewer:** Tom Markley **Approval Date:** 03/20/2007
Note: **Ok to Issue:**

Dept: Building **Status:** Approved with Conditions **Reviewer:** Tom Markley **Approval Date:** 03/20/2007
Note: **Ok to Issue:**

1) Application approval based upon information provided by applicant. Any deviation from approved plans requires separate review and approval prior to work.



General Building Permit Application

If you or the property owner owes real estate or personal property taxes or user charges on any property within the City, payment arrangements must be made before permits of any kind are accepted.

Location/Address of Construction: <u>48 REVERE ST</u>		
Total Square Footage of Proposed Structure	Square Footage of Lot <u>7533</u>	
Tax Assessor's Chart, Block & Lot Chart# Block# Lot# <u>124</u> <u>I</u> <u>017</u>	Owner: <u>WENDALL FLETCHER</u>	Telephone: <u>207-772-2128</u>
Lessee/Buyer's Name (If Applicable) <u>— 0 —</u>	Applicant name, address & telephone: <u>WENDALL FLETCHER</u> <u>48 REVERE ST</u> <u>PORTLAND, ME.</u> <u>04103</u>	Cost Of Work: \$ <u>2,000.00</u> Fee: \$ <u>40.00</u> C of O Fee: \$ _____
Current legal use (i.e. single family) <u>SINGLE FAMILY</u>	If vacant, what was the previous use? <u>N/A</u>	
Proposed Specific use: <u>FRONT STAIRS</u>	Is property part of a subdivision? <u>NO</u> If yes, please name <u>— 0 —</u>	
Project description: <u>REPLACE EXISTING STAIRS AT FRONT OF 48 REVERE ST.</u>		
Contractor's name, address & telephone: <u>JEFF LA COURSE 7 KINGS COURT N. WATERBORO ME 04061</u>		
Who should we contact when the permit is ready: <u>WENDALL FLETCHER 207-651-8422</u>		
Mailing address: _____ Phone: <u>772-2128</u>		

Please submit all of the information outlined in the Commercial Application Checklist.
Failure to do so will result in the automatic denial of your permit.

In order to be sure the City fully understands the full scope of the project, the Planning and Development Department may request additional information prior to the issuance of a permit. For further information visit us on-line at www.portlandmaine.gov, stop by the Building Inspections office, room 315 City Hall or call 874-8703.

I hereby certify that I am the Owner of record of the named property, or that the owner of record authorizes the proposed work and that I have been authorized by the owner to make this application as his/her authorized agent. I agree to conform to all applicable laws of this jurisdiction. In addition, if a permit for work described in this application is issued, I certify that the Code Official's authorized representative shall have the authority to enter all areas covered by this permit at any reasonable hour to enforce the provisions of the codes applicable to this permit.

Signature of applicant: <u>Wendall Fletcher</u>	Date: <u>3-20-07</u>
---	----------------------

This is not a permit; you may not commence ANY work until the permit is issued.

WENDALL FLETCHER—OWNER

1/4 = 1FT

REPLACE EXISTING
FRONT STAIRS

REVEVE ST.

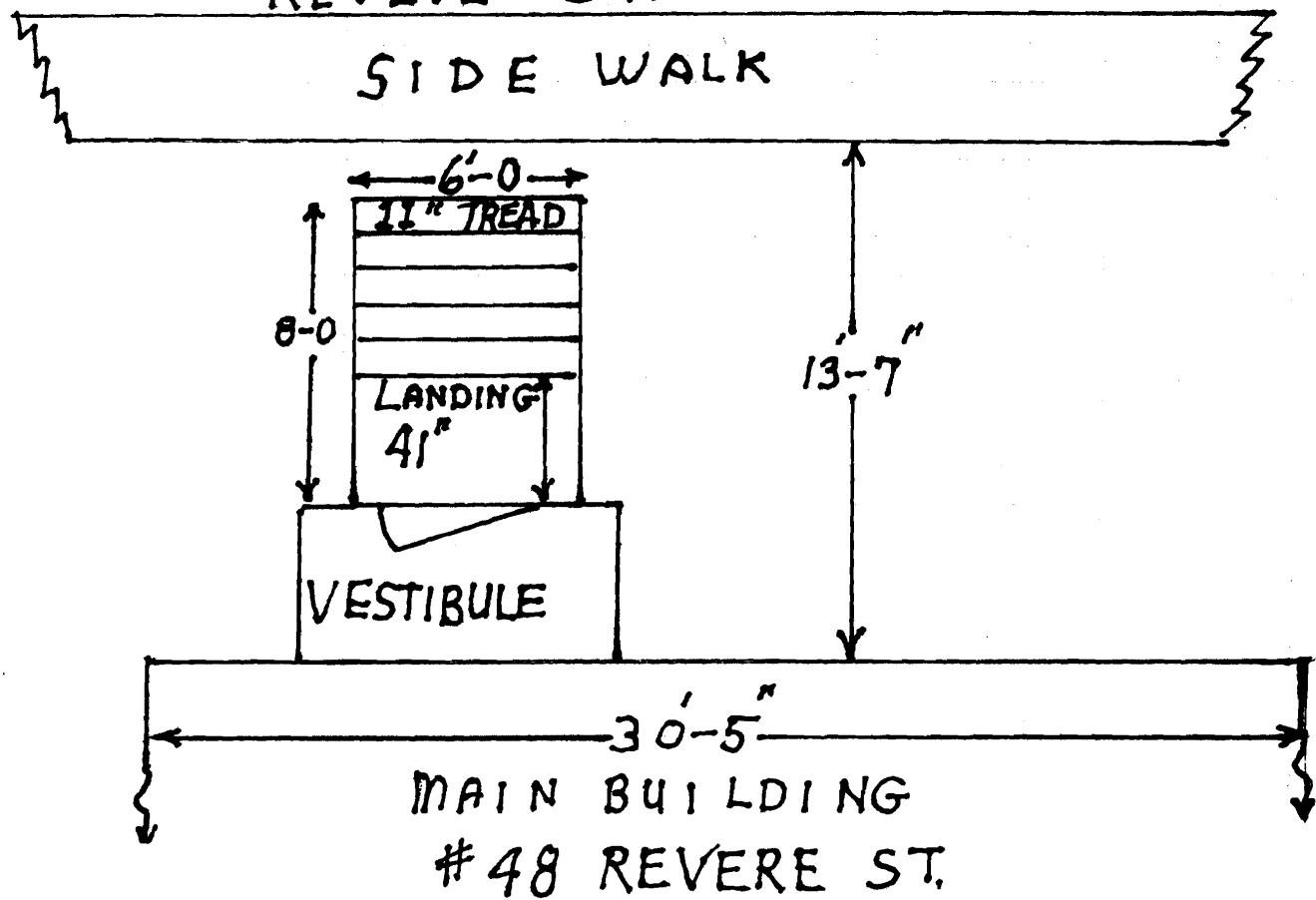

SCALE $3/4" = 1 \text{ FT}$

WENDALL FLETCHER - OWN
48 REVERE ST. REPLAC

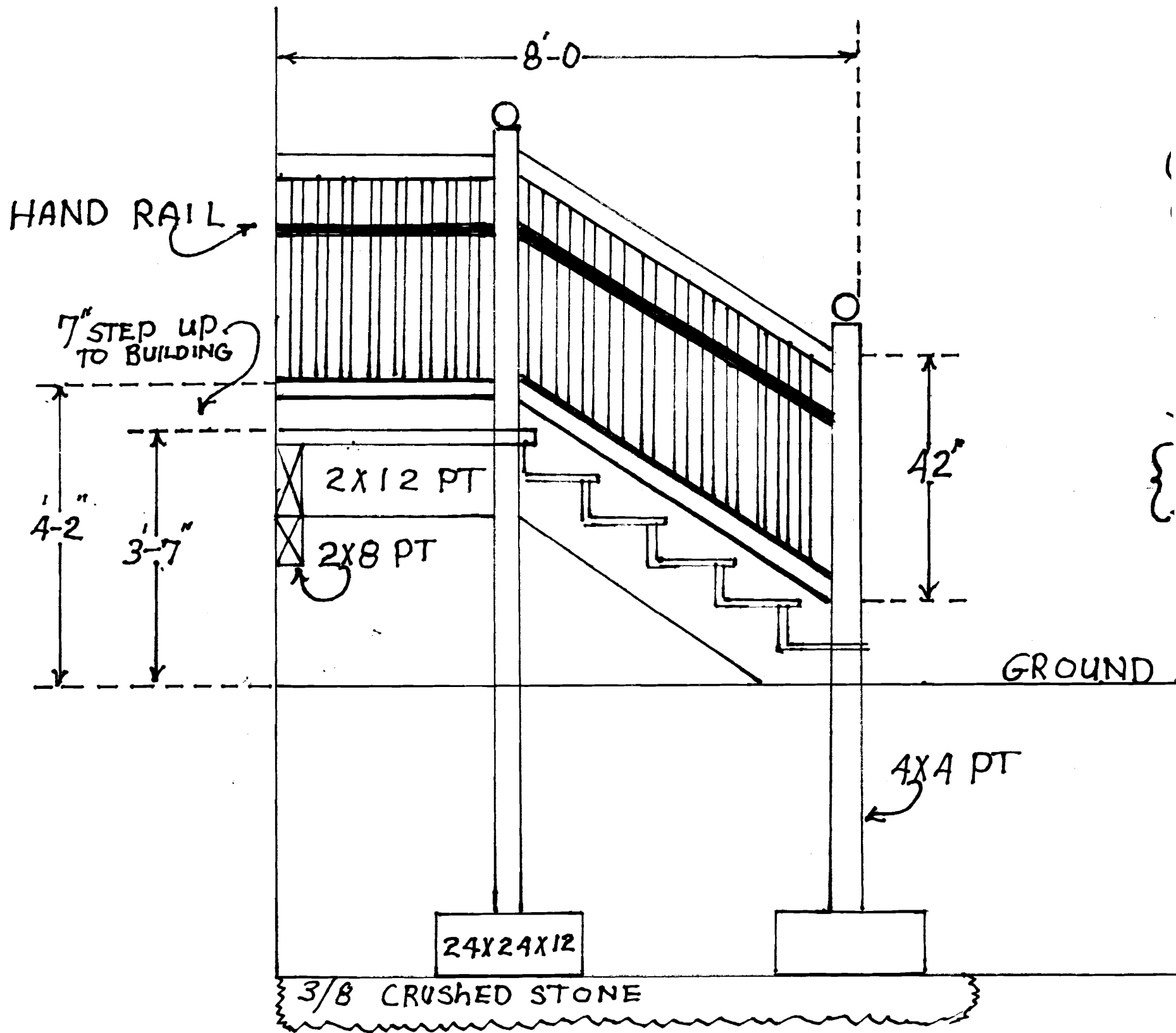

WENDALL FLETCHER-OWNER
PROPERTY - 48 REVERE ST.
PHONE 772-2128

CHART 124 Block I
LOT 017

SCF

REASON-BUILDING PERMIT
TO REPLACE EXISTING FRONT
STAIRS TO STREET

