

**STRUCTURAL NOTES:**

**DESIGN BASIS:**  
 2009 International Building Code.  
 Dead Loads: Self weight  
 Roof Snow Load: Pg=50psf, Ce=1.0, Cr=1.1, Pf=46psf  
 Live Loads: Exist stairs = 100.0 psf  
 Wind Speed: 100mph, I=1.0, Exposure B

- FOUNDATIONS:**
1. Bear footings on firm, undisturbed dense native soil at 4"-6" minimum below lowest adjacent finish or natural grade, which ever is lower.
  2. Assumed soil bearing pressure = 2,000 psf.
  3. Place foundation concrete only on clean, firm, dry bearing material.
  4. Engineer shall be notified if stone ledge or marine clay is found during excavation.
  5. Not used

- CONCRETE:**
1. Concrete regular weight (144 pcf) with Type II cement per ASTM C150, aggregate per ASTM C33, and potable water. No fly-ash permitted. Aggregate size = 1/2" maximum for footings and columns. Minimum compressive strength = 3000 psi for footings, 4,000psi for columns.
  2. All concrete exposed to freeze/thaw cycle to have 6% air entrainment.

- REINFORCING:**
1. ASTM A 615-S1, Grade 60 except #2 and #3 bars ASTM A615-S1: Grade 40.
  2. Lap splices in concrete: 42 bar diameters.
  3. Reinforcing shall be placed with 2" clearance at all surfaces exposed to earth, 1-1/2" at all wall and slab concrete exposed to weather.

- WOOD:**
1. General:
    - a. Each piece of rot resistant lumber shall be #2 SYP or better and bear the grade stamp of a grading rules agency approved by the American Lumber Standards Committee.
    - b. Inspect each existing piece of lumber, replace with like sized rot resistant treated lumber wherever rot is encountered.
    - c. Install solid blocking where required to create or maintain a continuous load path.
  2. Connections:
    - a. Use Simpson for all hardware specified. Substitutions will be entertained with prior approval.

- SUPPLEMENTARY NOTES:**
1. Verify soundness and condition of all existing wood structure prior to starting work. Notify the Engineer of any discrepancies or inconsistencies.
  2. Provide all necessary temporary bracing, shoring, guying or other means to avoid excessive stresses and to hold structural elements in place during construction.
  3. The intention of this drawing is to provide adequate footing and columns for the existing fire escape, existing structure has not been reviewed for adequacy.
  4. Engineer must review the work after completion.

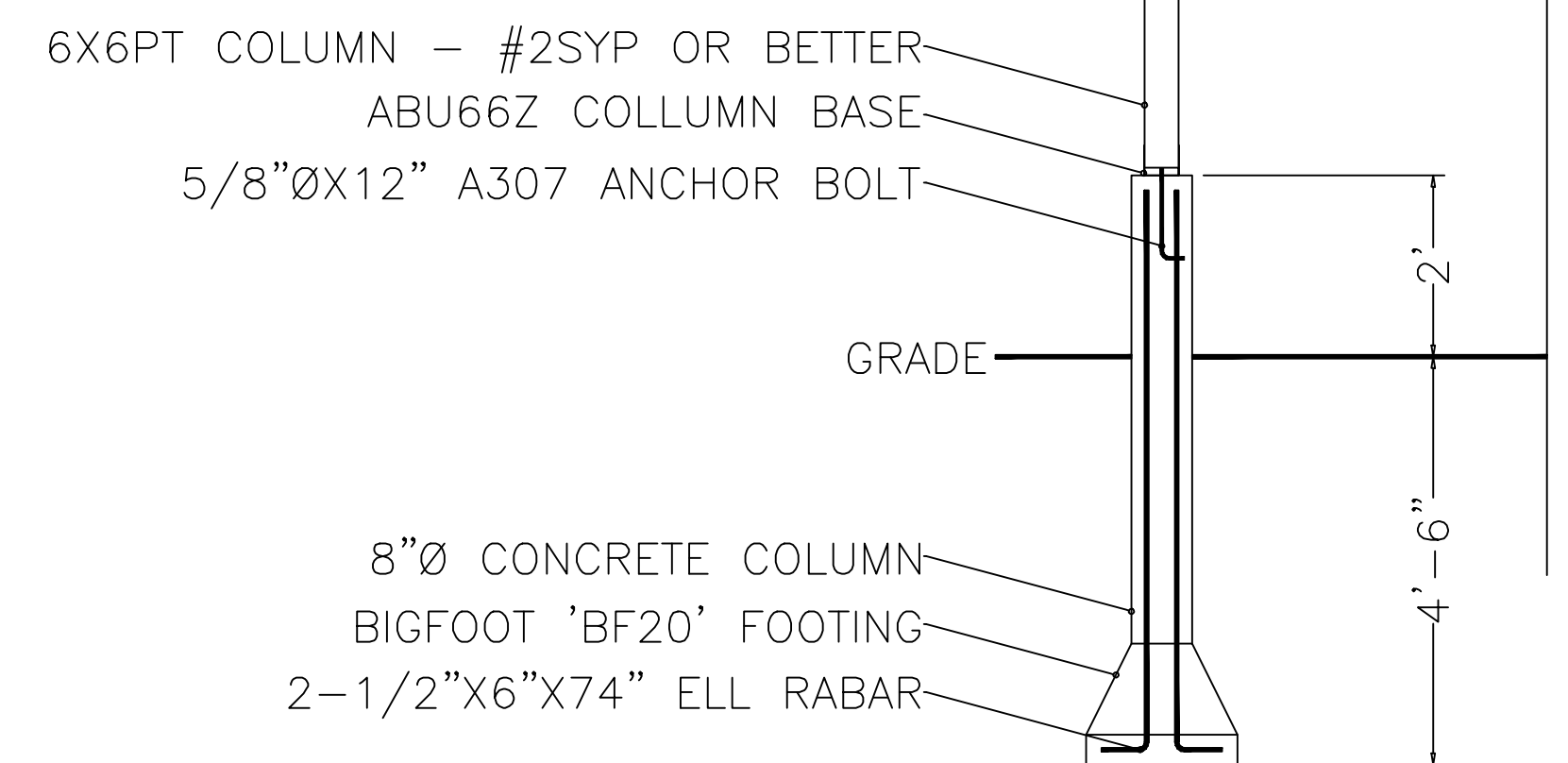
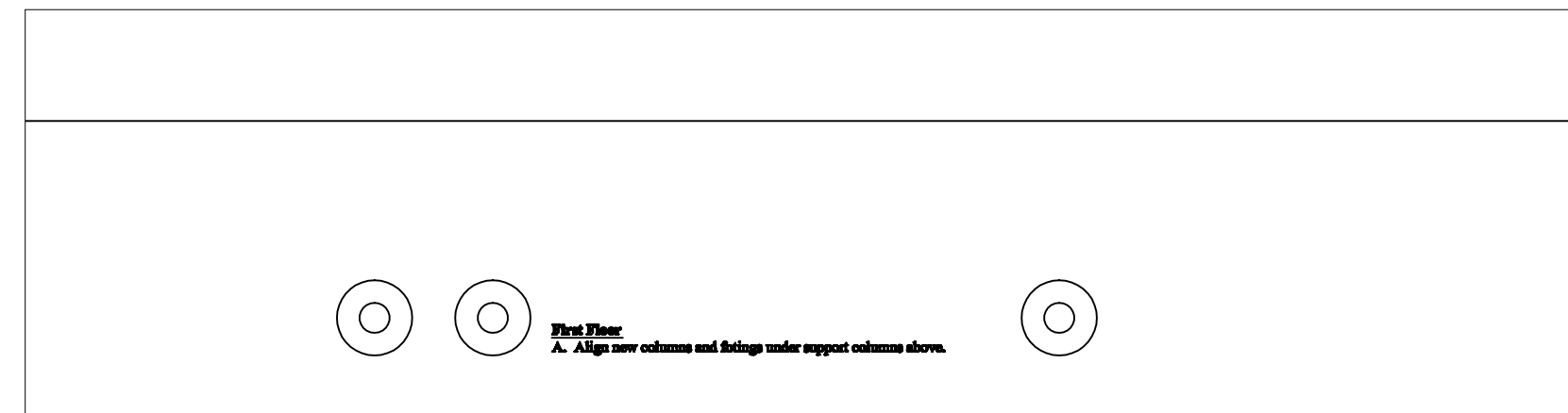
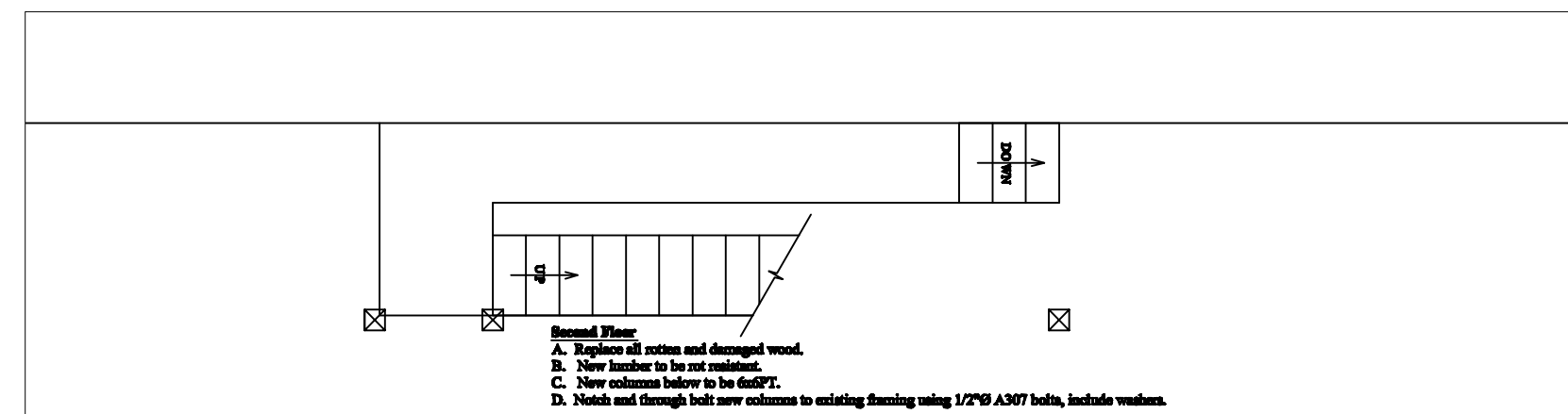
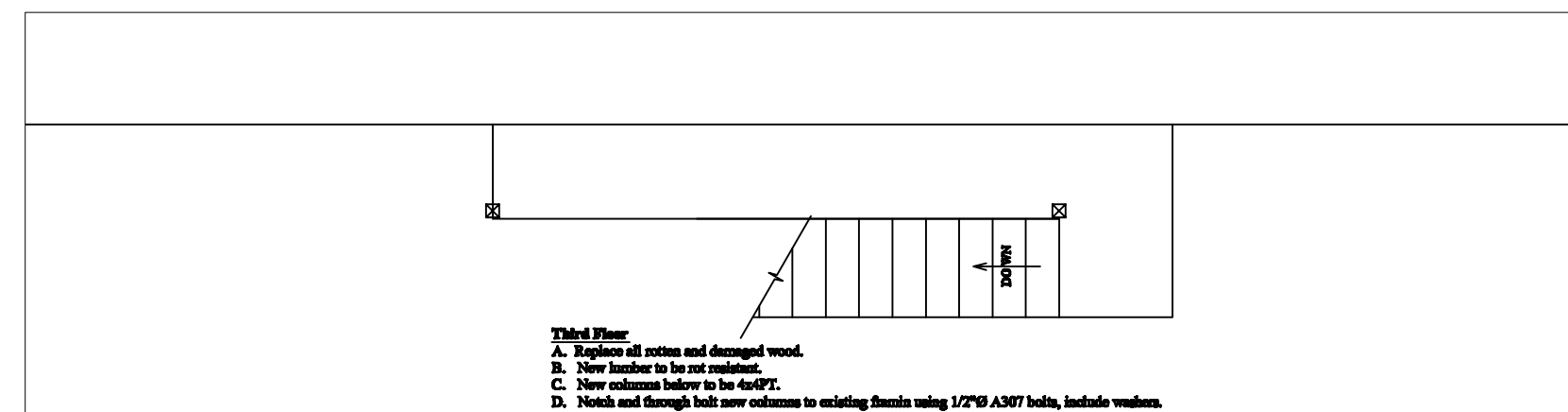

General Notes

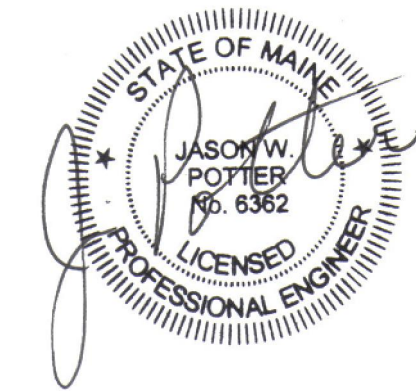

2	NOT USED	
1	NOT USED	
0	ISSUED FOR CONSTRUCTION	10/6/17
No.	Revision/Issue	Date

Firm Name and Address  
 WOODBURY HILL  
 PROFESSIONALS  
 8 WOODBURY HILL ROAD  
 AUBURN, MAINE 04210  
 (207) 783-4459

Project Name and Address  
 Apartment  
 245 Brighton Avenue  
 Portland, Maine  
 PLAN NOTES  
 & DETAILS

Project DJC MANAG'T	Sheet
Date 10/5/17	S1.0
Scale NONE	