



General Building Permit Application

If you or the property owner owes real estate or personal property taxes or user charges on any property within the City, payment arrangements must be made before permits of any kind are accepted.

Location/Address of Construction: <u>85 Fessenden St Portland ME</u>		
Total Square Footage of Proposed Structure/Area <u>2196</u>		Square Footage of Lot <u>0.142 acres</u>
Tax Assessor's Chart, Block & Lot Chart# Block# Lot# <u>117 B 014</u>	Applicant * must be owner, Lessee or Buyer* Name <u>Samantha Reed Smith</u> Address <u>85 Fessenden St</u> City, State & Zip <u>Portland ME 04103</u>	Telephone: <u>207 232 4846</u>
Lessee/DBA (If Applicable)	Owner (if different from Applicant) Name Address City, State & Zip	Cost Of Work: \$ <u>17,600.00</u> C of O Fee: \$ _____ Total Fee: \$ _____
Current legal use (i.e. single family) <u>two unit</u> If vacant, what was the previous use? _____ Proposed Specific use: <u>single family</u> Is property part of a subdivision? <u>no</u> If yes, please name _____ Project description: <u>see attached. change of use from 2 units to single family</u>		
Contractor's name: <u>Ken Kohl, carpenter ; mark Reed Smith</u> Address: _____ City, State & Zip _____ Telephone: _____ Who should we contact when the permit is ready: _____ Telephone: _____ Mailing address: _____		

Please submit all of the information outlined on the applicable Checklist. Failure to do so will result in the automatic denial of your permit.

In order to be sure the City fully understands the full scope of the project, the Planning and Development Department may request additional information prior to the issuance of a permit. For further information or to download copies of this form and other applications visit the Inspections Division on-line at www.portlandmaine.gov, or stop by the Inspections Division office, room 315 City Hall or call 874-8703.

I hereby certify that I am the Owner of record of the named property, or that the owner of record authorizes the proposed work and that I have been authorized by the owner to make this application as his/her authorized agent. I agree to conform to all applicable laws of this jurisdiction. In addition, if a permit for work described in this application is issued, I certify that the Code Official's authorized representative shall have the authority to enter all areas covered by this permit at any reasonable hour to enforce the provisions of the codes applicable to this permit.

Signature: S. Reed Smith Date: 12/10/10

This is not a permit; you may not commence ANY work until the permit is issued

85 Fessenden St

Change of Use: 2 unit to single family

Changes to house:

1. Removal of wall next to the first floor stairs and replacement of railings and stair treads
Estimated cost: \$3500
2. Replacement (putting back in) toilet and shower in second floor bathroom, re-flooring the room, and replacing sink. This area being was being used as the second floor kitchen when we moved in.
 - a. estimated cost: \$5500
3. Removal of stairs and deck on the exterior at the back of the house, and removal of door at the back of the house on the second floor (which was the second floor egress) with window put in to replace the door
 - a. Estimated cost: \$1500
4. Re-building deck on the back of the house, using pre-existing footprint
 - a. cost: \$7,100

TOTAL COST: \$17,600

85 Resenden St

FIRST FLOOR

ALTER

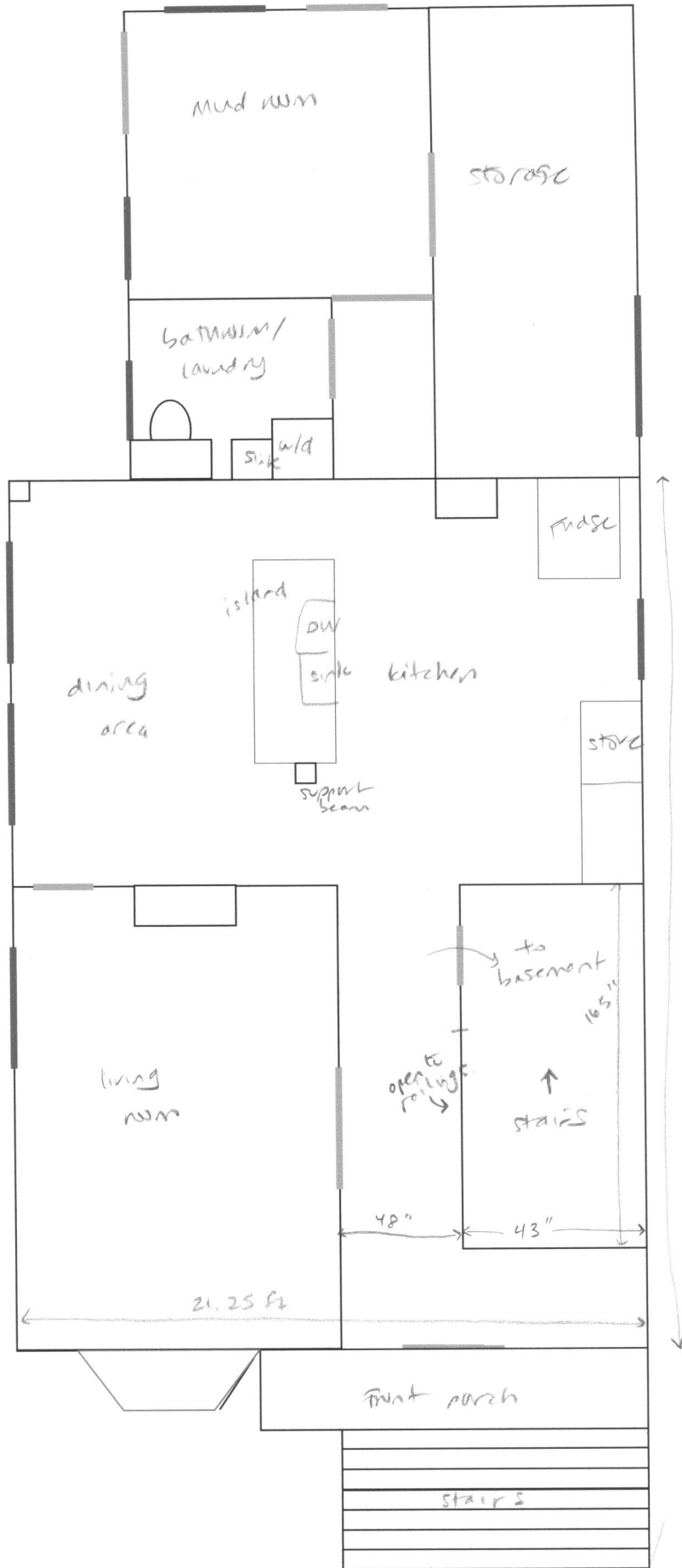

STAIRS
 STAIR TREADS
 40" W x 10.5" deep x
 8" height

RAILINGS
 SQUARE 1 3/8
 28" long
 3' apart
 handrail = 2 5/8"

Street

85 Resenden St

First floor

Before



85 Fessenden St.



Second Floor

BEFORE

street

85 Fessenden St

Second floor

APR 13

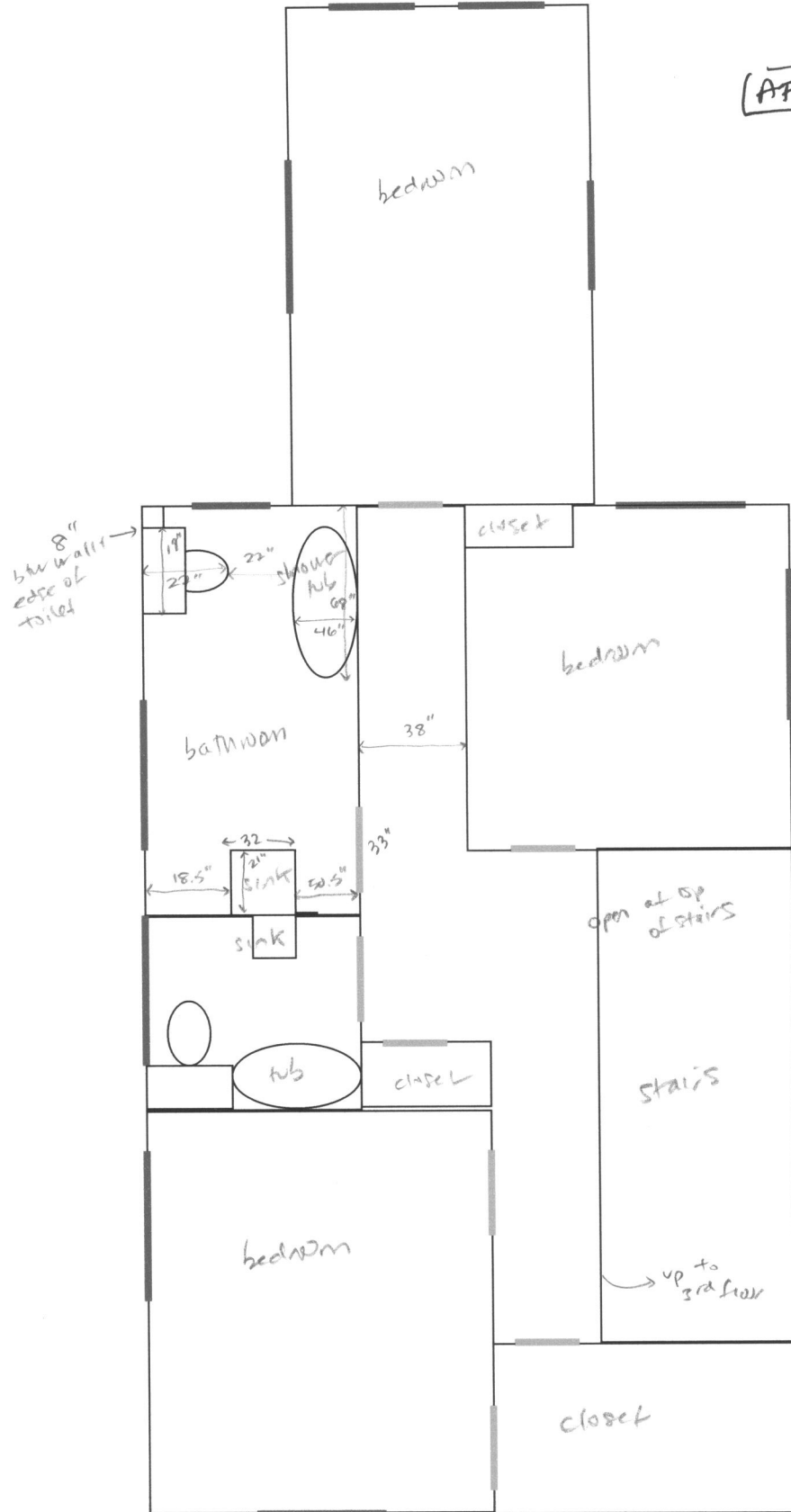

street

85 Rossden st

Third floor

street

Before and
After
(no changes)

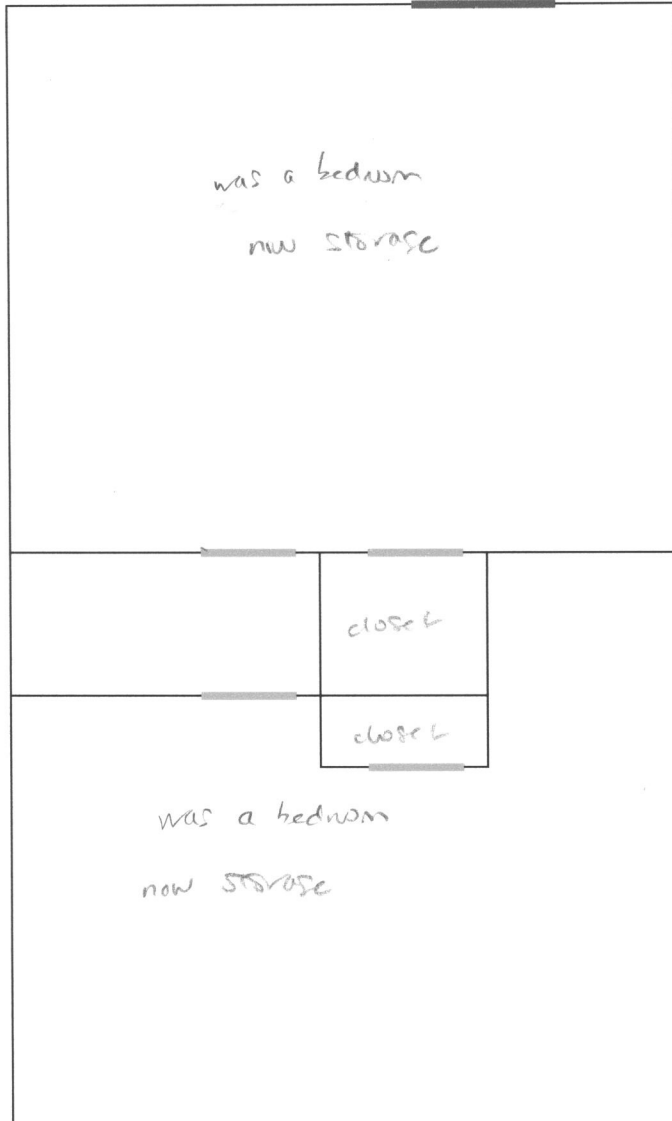

Back deck - Replaced old structure, same footprint

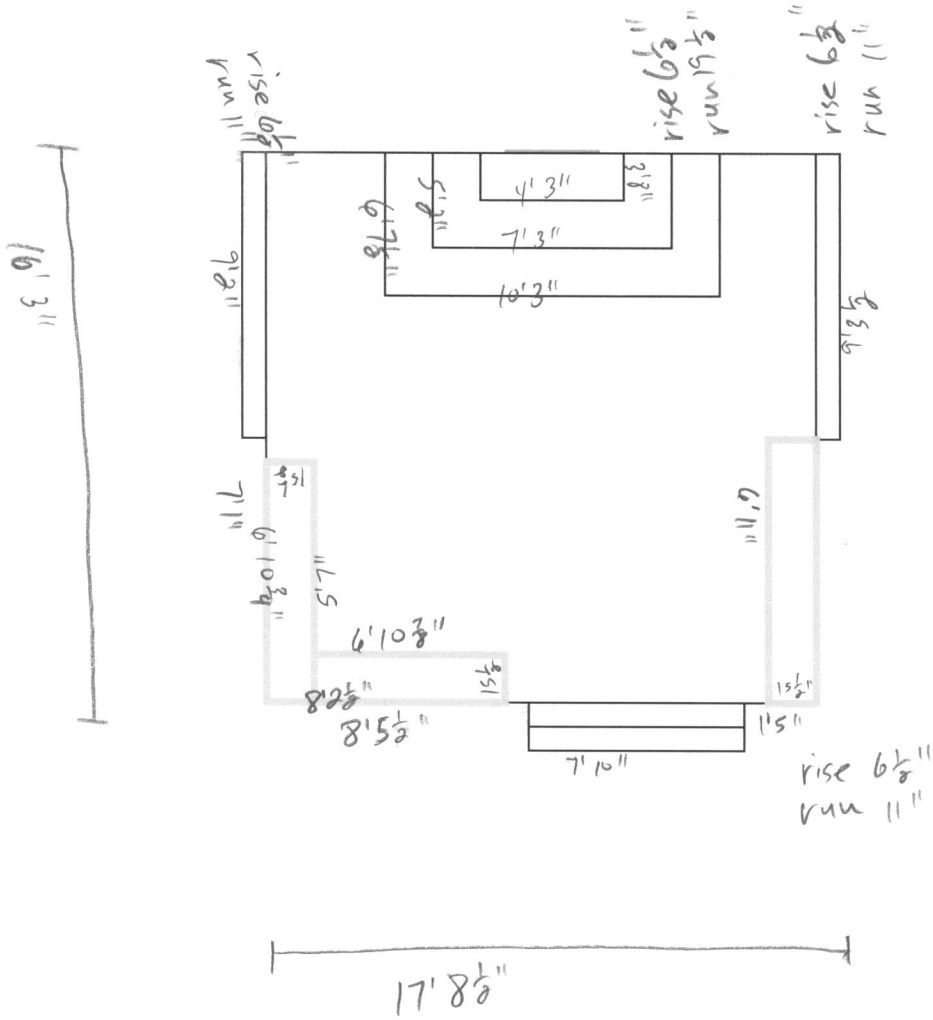

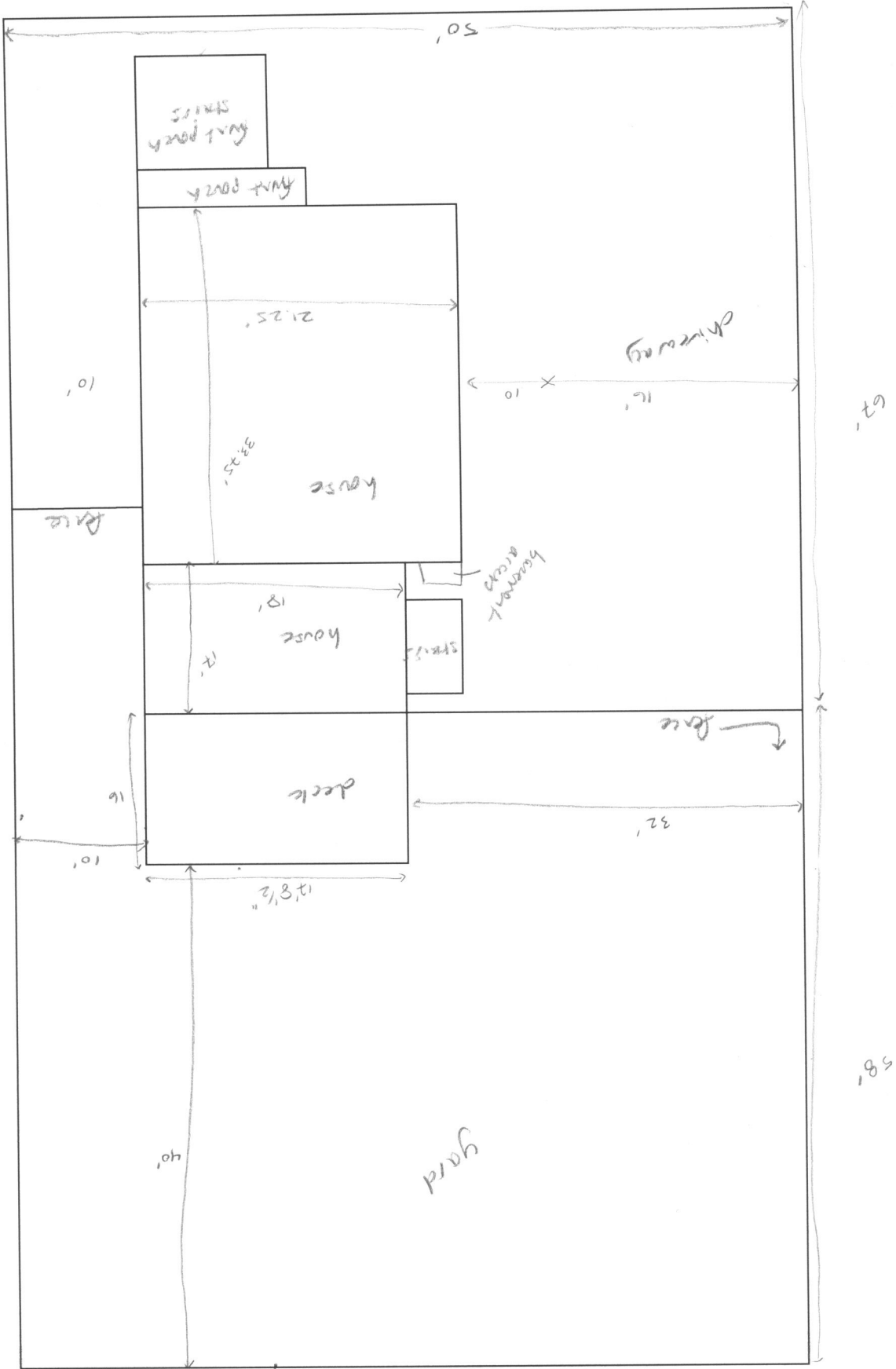

Site plan, 85 Fessenden street

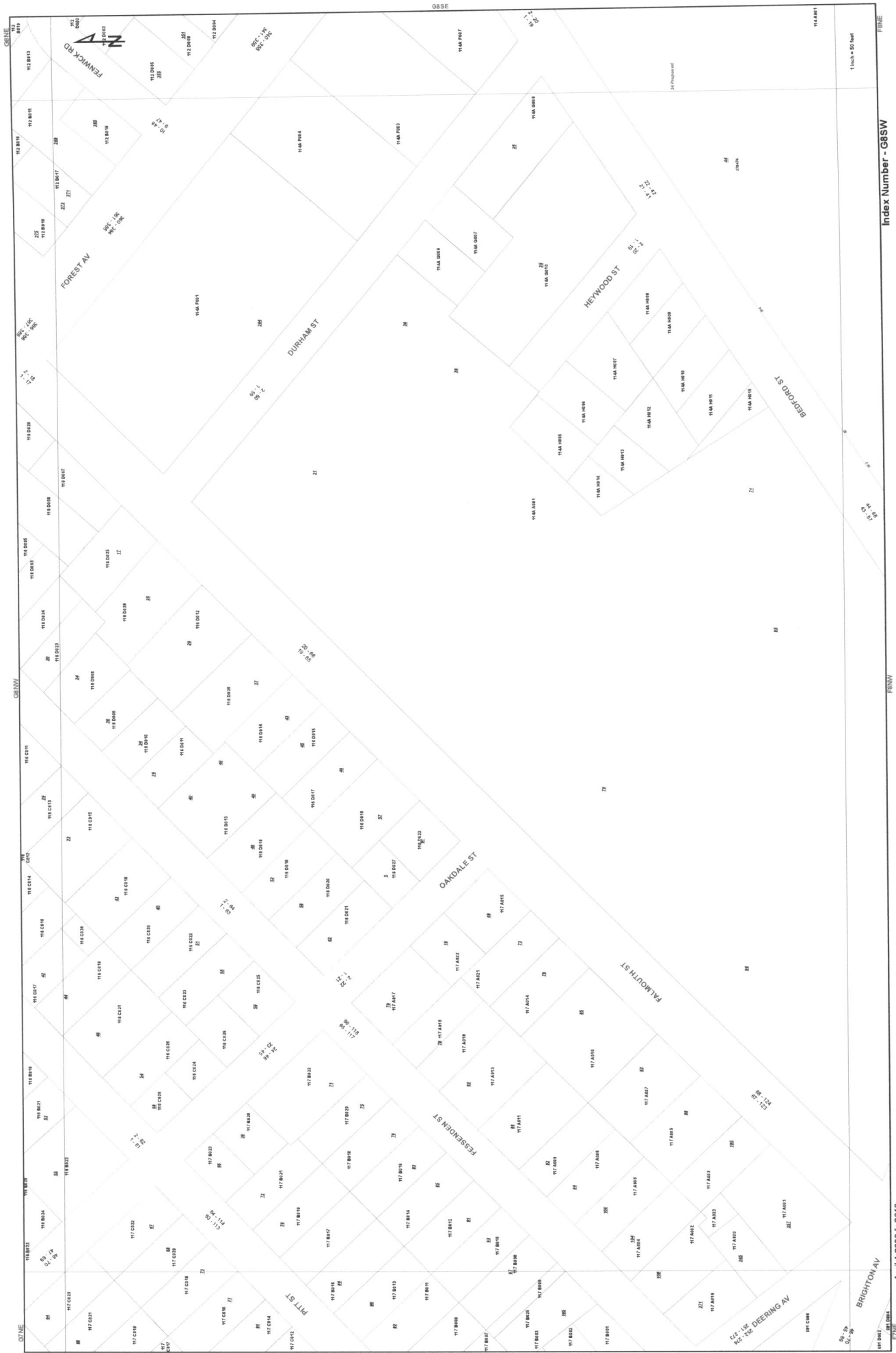

Index Number - G8SW

April 1 2009 by 2010

1 inch = 50 feet

BRIGHTON AV

PENNY

FINE

FINE

