

DISPLAY THIS CARD ON PRINCIPAL FRONTAGE OF WORK CITY OF PORTLAND

BUILDING DEPARTMENT

PERMIT

Permit Number: 071093

Please Read Application And Notes, If Any, Attached

This is to certify that GUARNA JOEL & RACHEL GUARNA Trise Dionne
has permission to Add 4' x 5' deck change window to door
AT 5 FELLOWS ST City 177 A013001 SEP 10 2007

provided that the person or persons, firm or corporation accepting this permit shall comply with all of the provisions of the Statutes of Maine and of the ordinances of the City of Portland regulating the construction, maintenance and use of buildings and structures, and of the application on file in this department.

PERMIT ISSUED
CITY OF PORTLAND

Apply to Public Works for street line and grade if nature of work requires such information.

Notification of inspection must be given and written permission procured before this building or part thereof is altered or closed-in.
48 HOUR NOTICE IS REQUIRED.

A certificate of occupancy must be procured by owner before this building or part thereof is occupied.

OTHER REQUIRED APPROVALS

Fire Dept. _____
Health Dept. _____
Appeal Board _____
Other _____
Department Name

Thomas M. Morley 9/10/07
Director - Building & Inspection Services

PENALTY FOR REMOVING THIS CARD

City of Portland, Maine - Building or Use Permit Application

389 Congress Street, 04101 Tel: (207) 874-8703, Fax: (207) 874-8716

Permit No: 07-1093	Issue Date:	CBL: 177 A013001
-----------------------	-------------	---------------------

Location of Construction: 5 FELLOWS ST	Owner Name: GUARNA JOEL & RACHEL GUA	Owner Address: 5 FELLOWS ST	Phone:
Business Name:	Contractor Name: Denise Dionne	Contractor Address: 35 Hammond Street Portland	Phone 2078078696
Lessee/Buyer's Name	Phone:	Permit Type: Additions - Dwellings	Zone: R3

Past Use: Single Family Home	Proposed Use: Single Family Home - Add 4' x 5' deck change window to door	Permit Fee: \$90.00	Cost of Work: \$7,000.00	CEO District: 3
Proposed Project Description: Add 4' x 5' deck change window to door		FIRE DEPT: <input type="checkbox"/> Approved <input type="checkbox"/> Denied	INSPECTION: Use Group: R3 Type: SB IRC 2003	
		Signature:	Signature: <i>Jm 9/10/07</i>	

PEDESTRIAN ACTIVITIES DISTRICT (P.A.D.)	
Action: <input type="checkbox"/> Approved <input type="checkbox"/> Approved w/Conditions <input type="checkbox"/> Denied	
Signature:	Date:

Permit Taken By: Idobson	Date Applied For: 09/07/2007	Zoning Approval
-----------------------------	---------------------------------	------------------------

- This permit application does not preclude the Applicant(s) from meeting applicable State and Federal Rules.
- Building permits do not include plumbing, septic or electrical work.
- Building permits are void if work is not started within six (6) months of the date of issuance. False information may invalidate a building permit and stop all work..

Special Zone or Reviews	Zoning Appeal	Historic Preservation
<input type="checkbox"/> Shoreland <input type="checkbox"/> Wetland <i>ck</i> <input type="checkbox"/> Flood Zone <input type="checkbox"/> Subdivision <input type="checkbox"/> Site Plan Maj <input type="checkbox"/> Minor <input type="checkbox"/> MM <input type="checkbox"/>	<input type="checkbox"/> Variance <input type="checkbox"/> Miscellaneous <input type="checkbox"/> Conditional Use <input type="checkbox"/> Interpretation <input type="checkbox"/> Approved <input type="checkbox"/> Denied	<input checked="" type="checkbox"/> Not in District or Landmark <input checked="" type="checkbox"/> Does Not Require Review <input type="checkbox"/> Requires Review <input type="checkbox"/> Approved <input type="checkbox"/> Approved w/Conditions <input type="checkbox"/> Denied
Date: <i>Jm 9/10/07</i>	Date:	Date: <i>Jm 9/10/07</i>

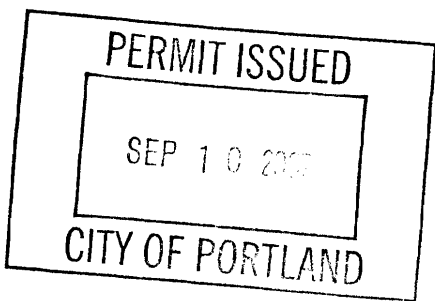

CERTIFICATION

I hereby certify that I am the owner of record of the named property, or that the proposed work is authorized by the owner of record and that I have been authorized by the owner to make this application as his authorized agent and I agree to conform to all applicable laws of this jurisdiction. In addition, if a permit for work described in the application is issued, I certify that the code official's authorized representative shall have the authority to enter all areas covered by such permit at any reasonable hour to enforce the provision of the code(s) applicable to such permit.

SIGNATURE OF APPLICANT	ADDRESS	DATE	PHONE
RESPONSIBLE PERSON IN CHARGE OF WORK, TITLE		DATE	PHONE

City of Portland, Maine - Building or Use Permit

389 Congress Street, 04101 Tel: (207) 874-8703, Fax: (207) 874-8716

Permit No: 07-1093	Date Applied For: 09/07/2007	CBL: 177 A013001
------------------------------	--	----------------------------

Location of Construction: 5 FELLOWS ST	Owner Name: GUARNA JOEL & RACHEL GUA	Owner Address: 5 FELLOWS ST	Phone:
Business Name:	Contractor Name: Denise Dionne	Contractor Address: 35 Hammond Street Portland	Phone (207) 807-8696
Lessee/Buyer's Name	Phone:	Permit Type: Additions - Dwellings	

Proposed Use: Single Family Home - Add 4' x 5' deck change window to door	Proposed Project Description: Add 4' x 5' deck change window to door
---	--

Dept: Zoning **Status:** Approved with Conditions **Reviewer:** **Approval Date:** **Ok to Issue:**

Note:
1) This property shall remain a single family dwelling. Any change of use shall require a separate permit application for review and approval.

Dept: Building **Status:** Approved with Conditions **Reviewer:** Tom Markley **Approval Date:** 09/10/2007 **Ok to Issue:**

Note:
1) Separate permits are required for any electrical, plumbing, or HVAC systems. Separate plans may need to be submitted for approval as a part of this process.
2) Application approval based upon information provided by applicant. Any deviation from approved plans requires separate review and approval prior to work.



General Building Permit Application

If you or the property owner owes real estate or personal property taxes or user charges on any property within the City, payment arrangements must be made before permits of any kind are accepted.

Location/Address of Construction: <u>5 FELLOWS STREET</u>		
Total Square Footage of Proposed Structure/Area <u>X</u>		Square Footage of Lot <u>X</u>
Tax Assessor's Chart, Block & Lot Chart# <u>X 177</u> Block# <u>A</u> Lot# <u>13</u>	Applicant *must be owner, Lessee or Buyer* Name <u>RACHEAL GUARNA</u> Address <u>5 FELLOWS ST</u> City, State & Zip <u>PORTLAND ME 04101</u>	Telephone: <u>207-272-8692</u>
Lessee/DBA (If Applicable) <u>N/A</u>	Owner (if different from Applicant) Name <u>SAME AS ABOVE</u> Address <u>ABOVE</u> City, State & Zip _____	Cost Of Work: \$ <u>7000.00</u> C of O Fee: \$ <u>N/A</u> Total Fee: \$ _____
Current legal use (i.e. single family) <u>SINGLE FAMILY</u> If vacant, what was the previous use? _____ Proposed Specific use: _____ Is property part of a subdivision? _____ If yes, please name _____ Project description: <u>CONVERTING WINDOW TO DOOR OPENING WITH 4'X5' DECK AND STAIRS TO EXTERIOR OF HOUSE</u>		
Contractor's name: <u>DENISE DIONNE</u> Address: <u>35 HAMMOND STREET</u> City, State & Zip <u>PORTLAND ME 04101</u> Telephone: <u>807-3636</u> Who should we contact when the permit is ready: <u>DENISE 807-3636</u> Telephone: _____ Mailing address: _____		

Please submit all of the information outlined on the applicable Checklist. Failure to do so will result in the automatic denial of your permit.

In order to be sure the City fully understands the full scope of the project, the Planning and Development Department may request additional information prior to the issuance of a permit. For further information or to download copies of this form and other applications visit the Inspections Division on-line at www.portlandmaine.gov, or stop by the Inspections Division office, room 315 City Hall or call 874-8703.

I hereby certify that I am the Owner of record of the named property, or that the owner of record authorizes the proposed work and that I have been authorized by the owner to make this application as his/her authorized agent. I agree to conform to all applicable laws of this jurisdiction. In addition, if a permit for work described in this application is issued, I certify that the Code Official's authorized representative shall have the authority to enter all areas covered by this permit at any reasonable hour to enforce the provisions of the codes applicable to this permit.

Signature: [Signature] Date: 8-31-07

This is not a permit; you may not commence ANY work until the permit is issue

• ALL WOOD PRESSURE TREATED

• DECK S FELLOWS

2.

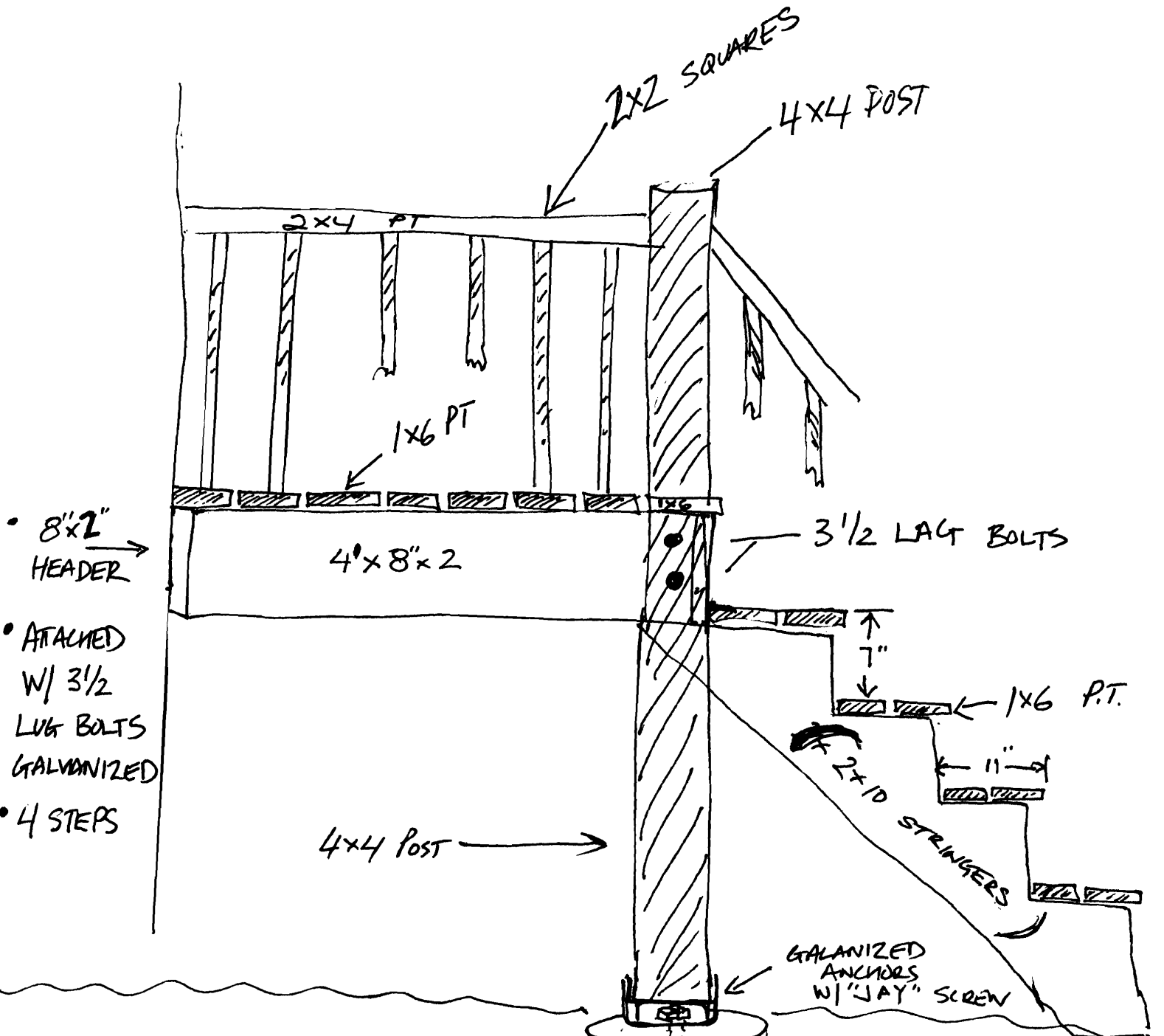

- ATTACHED W/ 3 1/2 LAG BOLTS GALVANIZED
- 4 STEPS

62 Posts
 Sides 16 FT + 28 FT
 Rear 25 +

8" WIDE TUBE

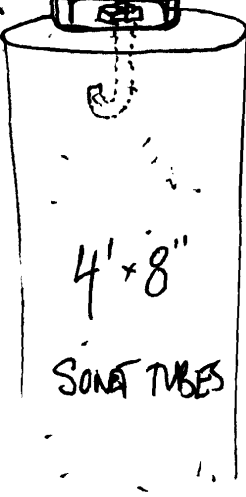

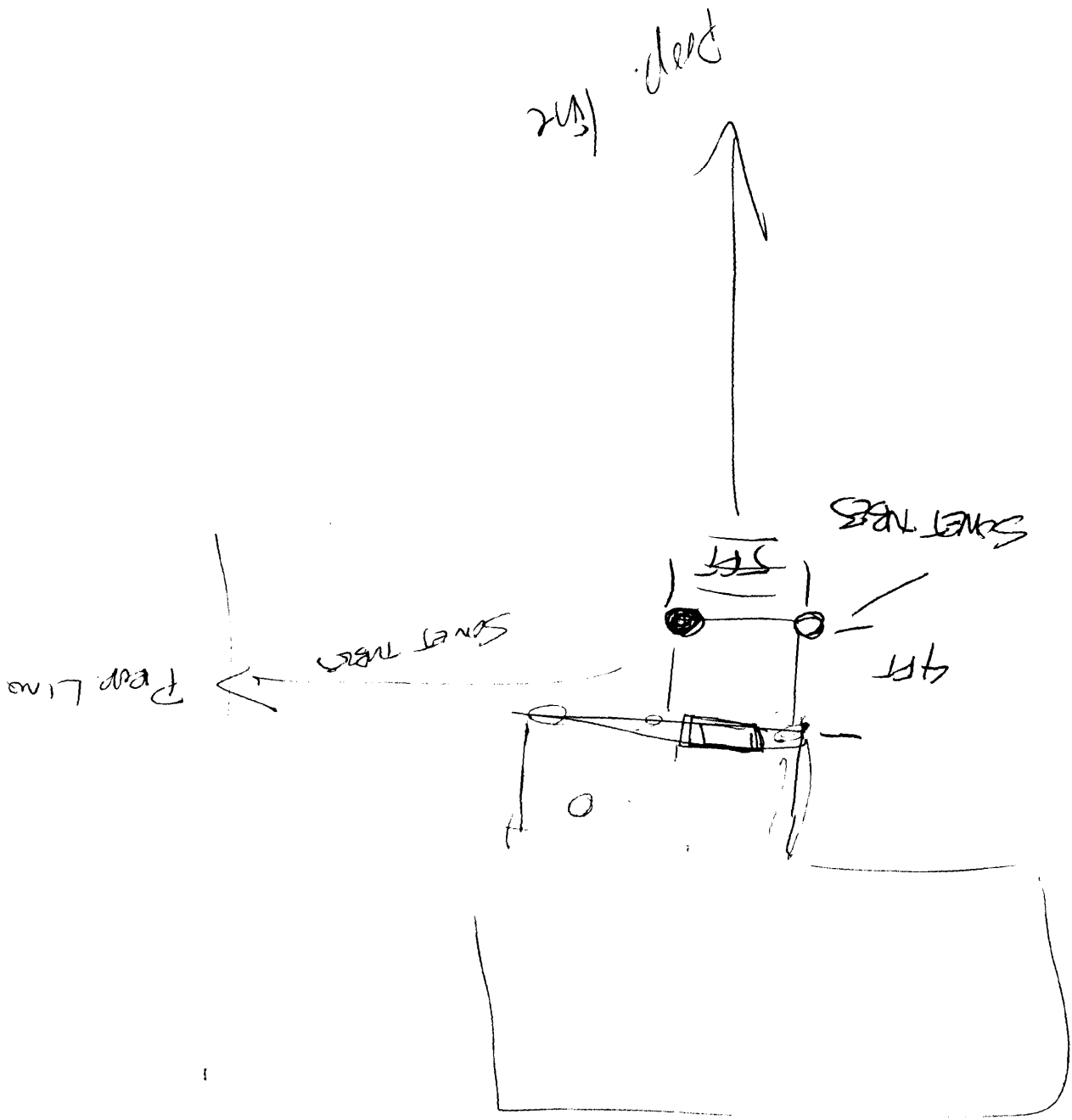

Pl. 1x6 x 10

TOP VIEW DECK 5.

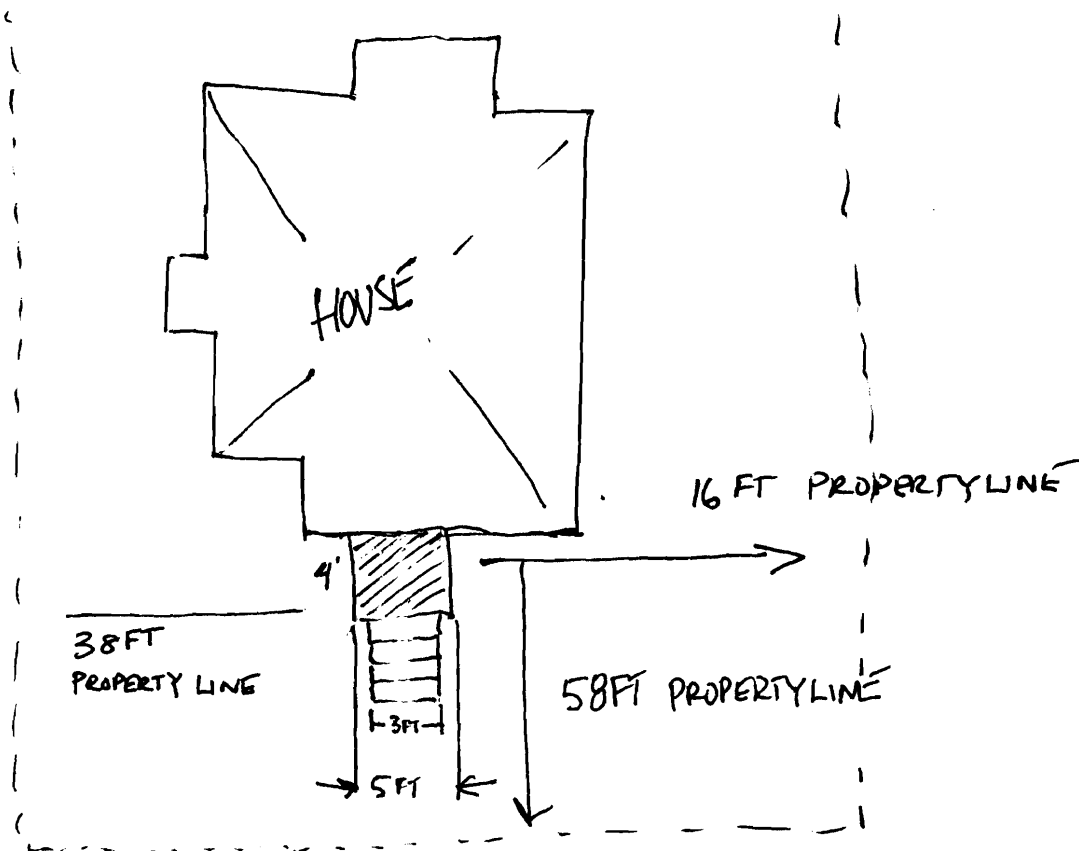
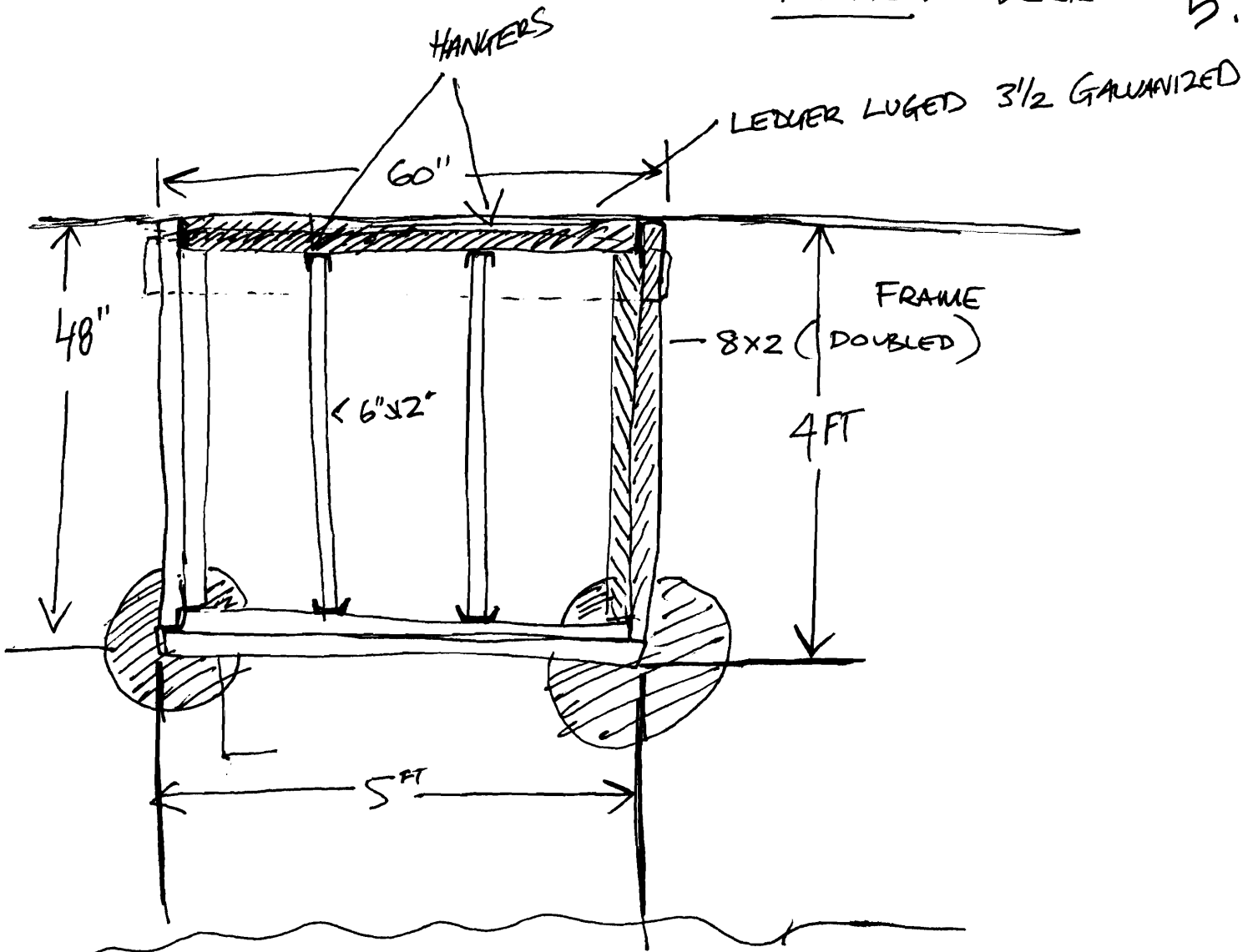

4.

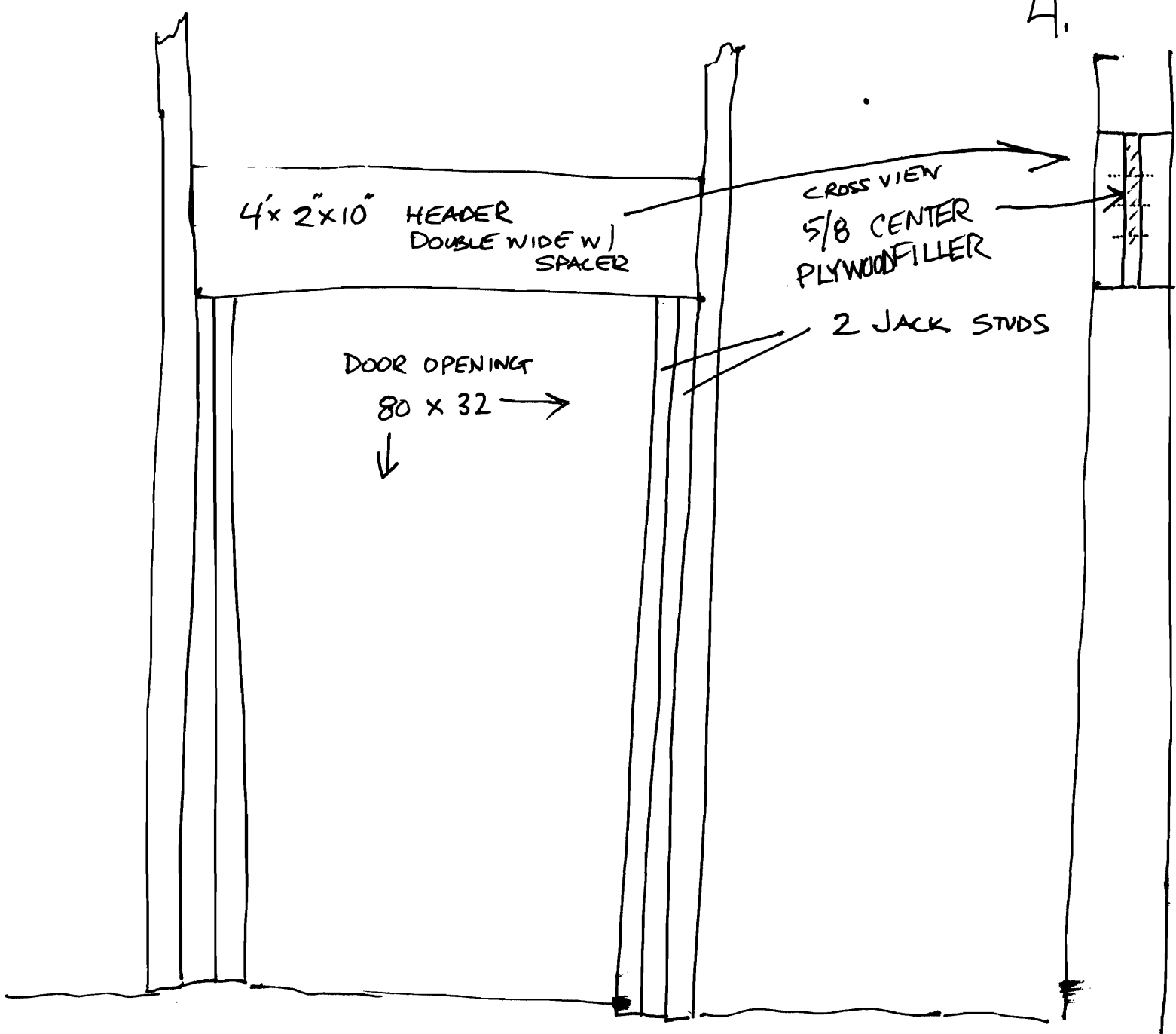

● WINDOW TO DOOR OPENING.

RACHEL / S FELLOWS

6.

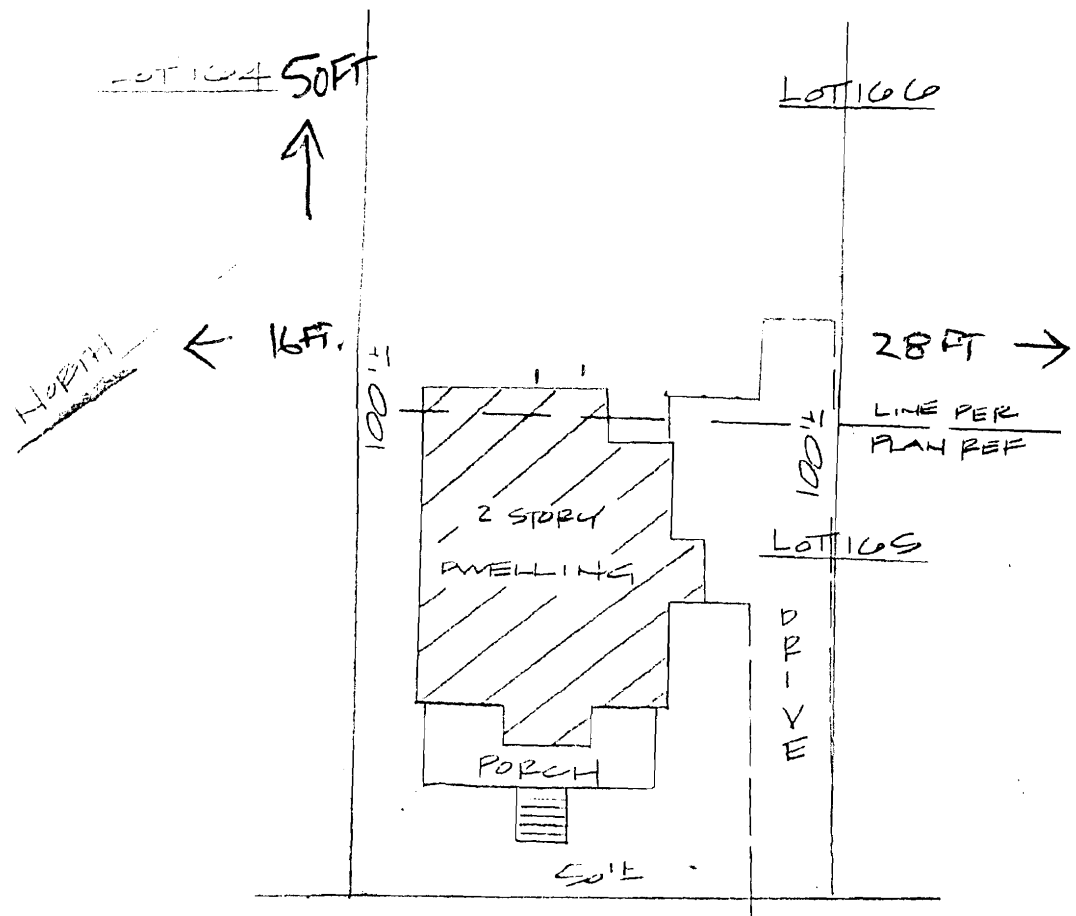

FELLOWS STREET TO BRIGHTON AVE
 INSP. BY NDB

SEE PROVIDED TITLE REFERENCES FOR APPLICABLE APPURTENANCES, IF ANY.

APPLICANT: Rachel B. and Joel Guarna REQ. PARTY: Atlantic Title Company
 OWNER: Charles David Carey, III ATTORNEY: _____
 LENDER: NE Moves Mortgage, LLC FILE No. 20620018 CLIENT No. 1272809

TITLE REFERENCES:
 DEED BOOK: 11584 PAGE: 81 P/O
 PLAN BOOK: 11 PAGE: 123 LOT: 165, 166
 COUNTY: Cumberland

MUNICIPAL REFERENCE:
 MAP: 177 BLOCK: A LOT: 13

THE DWELLING DOES NOT FALL WITHIN A SPECIAL FLOOD HAZARD ZONE PER FEMA COMMUNITY MAP No. 230052
 PANEL: 0013B ZONE: C DATE: 7/15/2006

THE DWELLING WAS IN COMPLIANCE WITH MUNICIPAL ZONING SETBACK REQUIREMENTS AT THE TIME OF CONSTRUCTION.

COMMENTS:

James D. Nadeau, LLC
 Professional Land Surveyors

[Signature]
 12-4-6

918 BRIGHTON AVENUE
 PORTLAND, ME 04108
 PH (207) 878-7870
 FAX (207) 878-7871
 THIS INSPECTION IS VALID ONLY WITH AN EMBOSSED SEAL AND IS NULL & VOID 90 DAYS AFTER INSPECTION DATE.

THIS IS NOT A BOUNDARY SURVEY - NOT FOR RECORDING

ADD ON / REVISED *
WINDOW ONLY *

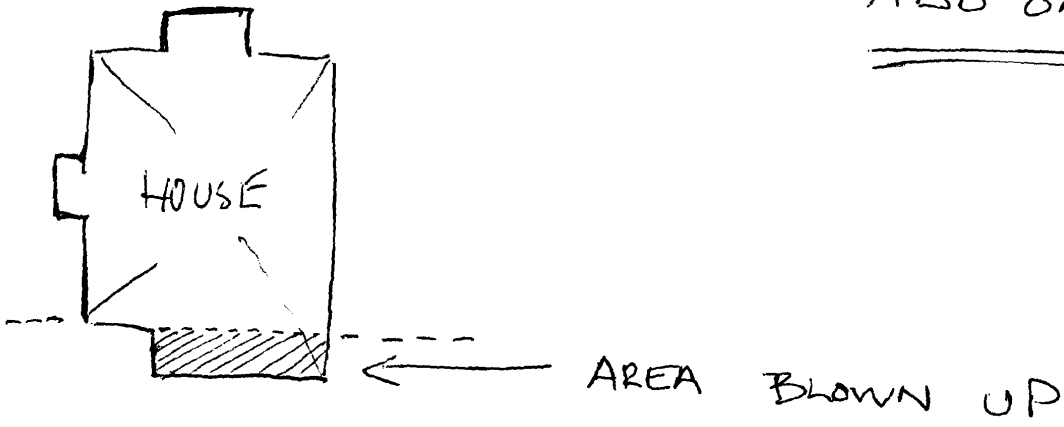

177-A-14

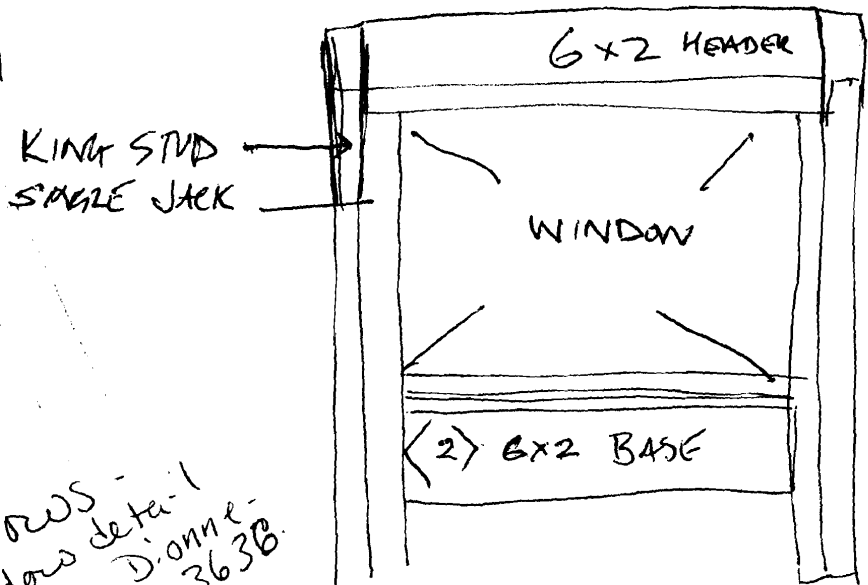
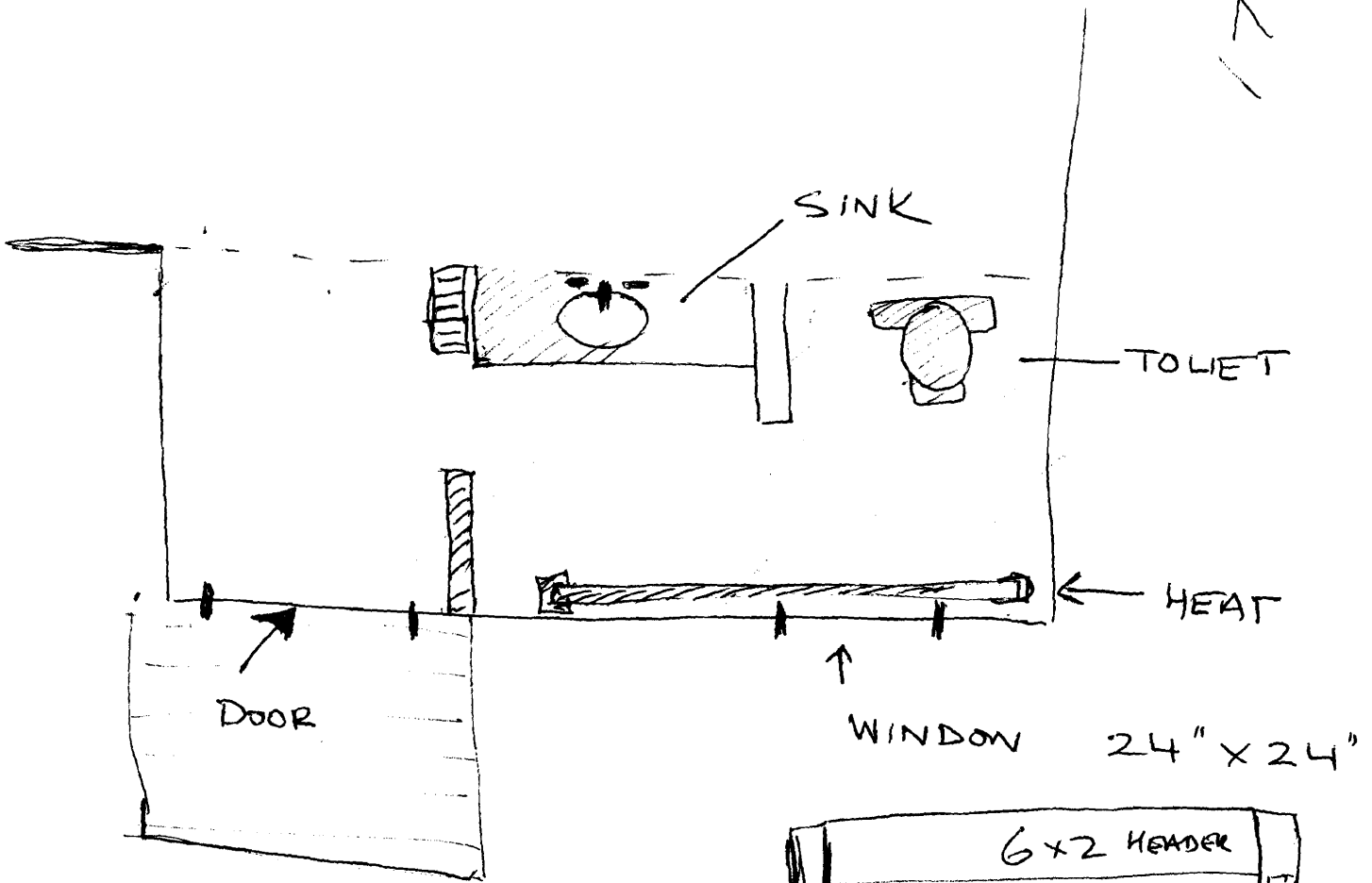

007 25 007

- S Fellows -
Window detail
- Denise Dionne -
807-3636