

Owner's Manual & Assembly Instructions

Y01

Model No. **VD108-A** □

697.68618 □

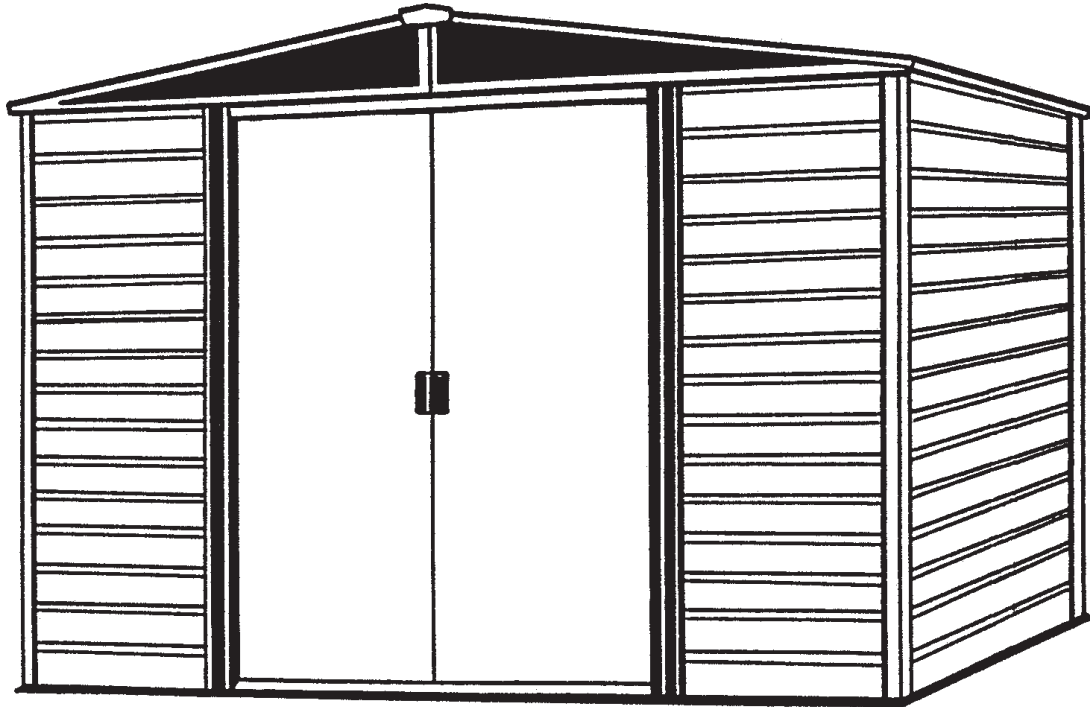

708851207

BUILDING DIMENSIONS * Size rounded off to the nearest foot



CAUTION: SOME PARTS HAVE SHARP EDGES. CARE MUST BE TAKEN WHEN HANDLING THE VARIOUS PIECES TO AVOID A MISHAP. FOR SAFETY SAKE, PLEASE READ SAFETY INFORMATION PROVIDED IN THIS MANUAL BEFORE BEGINNING CONSTRUCTION. WEAR GLOVES WHEN HANDLING METAL PARTS.

*Approx. Size	Foundation Size	Storage Area Sq. Ft. Cu. Ft.		Exterior Dimensions (Roof Edge to Roof Edge)			Interior Dimensions (Wall to Wall)			Door Opening	
				Width	Depth	Height	Width	Depth	Height	Width	Height
10' x 8'	121" x 92 3/4"	74	470	123 1/4"	95 1/4"	82 1/8"	118 1/4"	90"	80 7/8"	55 1/2"	69 1/4"
3,0m x 2,3m	307cm x 236cm	6,9m ²	13,3m ³	313cm	242cm	209cm	300cm	229cm	205cm	141cm	176cm

BEFORE YOU BEGIN....

A2

Owner's Manual

Before beginning construction, check local building codes regarding footings, location and other requirements. Study and understand this owner's manual.

Important information and helpful tips will make your construction easier and more enjoyable.

Assembly Instructions: Instructions are supplied in this manual and contain all appropriate information for your building model. Review all instructions before you begin, and during assembly, follow the step sequence carefully for correct results.

Foundation and Anchoring: Your storage building must be anchored to prevent wind damage. A foundation is also necessary as a base in order to construct a square and level building. Anchoring and foundation materials are not included with your building. We recommend the combined use of an **Arrow Floor Frame Kit** and an **Arrow Anchoring Kit** as an effective method of securing your building to the ground (Available by mail order or at your local dealer) or you may construct a foundation and anchoring system of your choice. Your assembly instructions provide information on a few methods commonly used to secure and level a storage building.

Parts and Parts List: Check to be sure that you have all the necessary parts for your building.

- All part numbers can be found on the parts. All of these numbers (before the -) must agree with the numbers on the parts list. The parts list is located on page 12.

- If you find that a part is missing, include the model number of your building and contact:

Arrow Group Industries, Inc. Customer Service Department
Route 50 East Breese, Illinois 62230
1-800-851-1085

- Separate contents of the carton by the part number while reviewing parts list. The first few steps show how to join related parts to make larger sub assemblies which will be used later.

- Familiarize yourself with the hardware and fasteners for easier use during construction. These are packaged within the carton. Note that extra fasteners have been supplied for your convenience.

PLAN AHEAD...

A3

Watch the Weather: Be sure the day you select to install your building is dry and calm. Do not attempt to assemble your building on a windy day. Be careful on wet or muddy ground.

Teamwork: Whenever possible, two or more people should work together to assemble your building. One person can position parts or panels while the other is able to handle the fasteners and the tools.

Tools and Materials: These are some basic tools and materials you will need for the construction of your building. Decide which method of anchoring and the type of foundation you wish to use in order to form a complete list of the materials you will need.

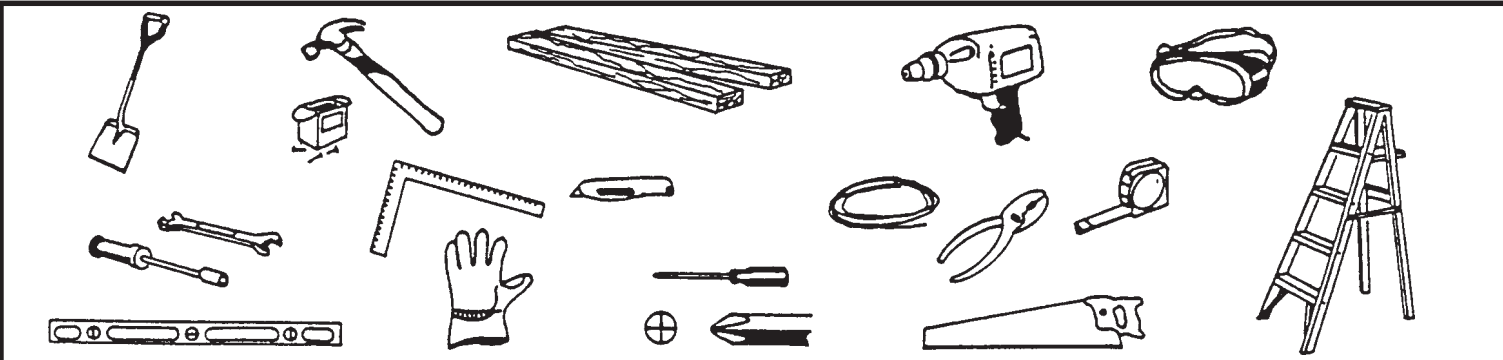

<p>Required</p> <ul style="list-style-type: none">• Eye Goggles• No. 2 Phillips Screwdriver (With Hardened Magnetic Tip) <p>Note: A power screwdriver or variable speed drill with Phillips-tip attachment can speed assembly by as much as 40%.</p>	<p>Required</p> <ul style="list-style-type: none">• Work Gloves• Step Ladder• Utility Knife / Scissors• Pliers• Carpenter's Level• Tape Measure	<p>Optional Time-Savers</p> <ul style="list-style-type: none">• Wrench / Nut Driver• Electric / Cordless Drill• Square• String (for squaring frame)	<p>Foundation Preparation</p> <ul style="list-style-type: none">• Hammer and Nails• Spade or Shovel• Hand Saw / Power Saw• Lumber and/or Concrete
---	--	--	--

Selecting and Preparing Your Site: Before assembly, you will want to decide on a location for your building. The best location is a level area with good drainage.

- Allow enough working space for ease of moving parts into position during assembly. Be sure there will be enough space at entrance for doors to open fully and enough space around the building to be able to fasten the panel screws from the outside.

- Before you begin the first steps in assembling your parts, a foundation should be constructed and an anchoring system should be ready to use.

SAFETY FIRST...

A4

Safety precautions are important to follow throughout the construction of your building.

•Care must be taken when handling various pieces of your building since some contain sharp edges. Please wear work gloves, eye protection and long sleeves when assembling or performing any maintenance on your building.

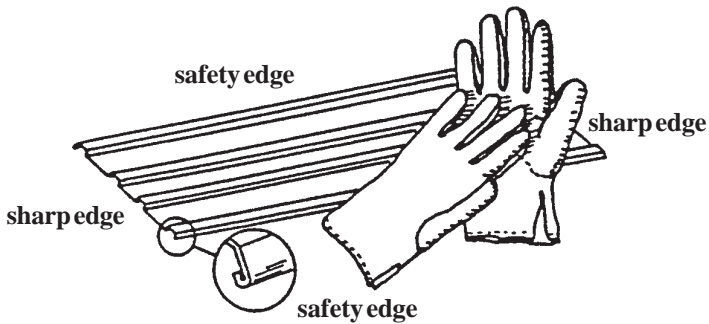

•Keep children and pets away from worksite to avoid distractions and any accidents which may occur.



•Never concentrate your total weight on the roof of the building. When using a step ladder make sure that it is fully open and on even ground before climbing on it.

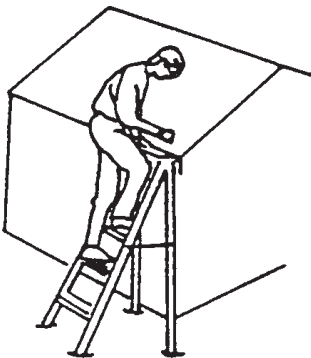

•Practice caution with the tools being used in the assembly of this building. Be familiar with the operation of all power tools.

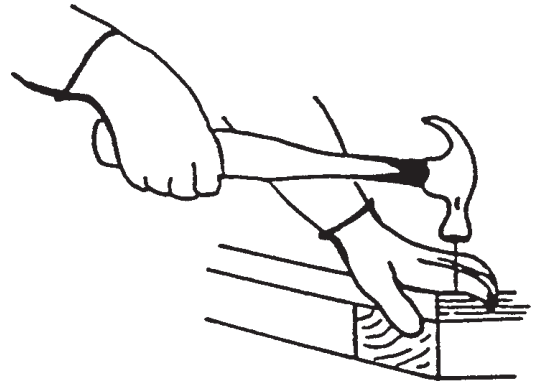

•Do not attempt to assemble the building if parts are missing because any building left partially assembled may be seriously damaged by light winds. Call 1-800-851-1085

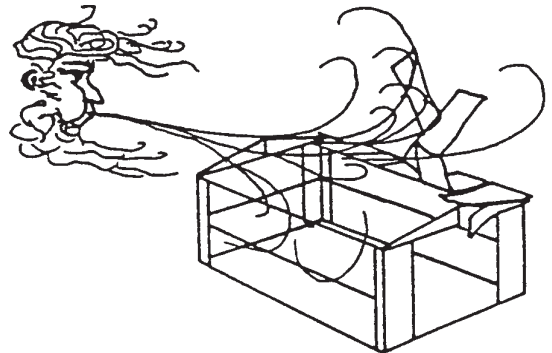

•Do not attempt to assemble the building on a windy day, because the large panels acting as a "sail", can be whipped about by the wind making construction difficult and unsafe.

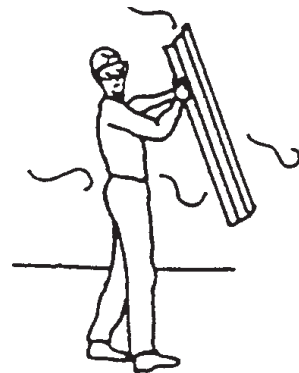

CARE & MAINTENANCE....

A5 Web

Finish: For long lasting finish, periodically clean and wax the exterior surface. Touch-up scratches as soon as you notice them on your unit. Immediately clean the area with a wire brush; wash it and apply touch-up paint per manufacturer's recommendation.

Roof: Keep roof clear of leaves and snow with long handled, soft-bristled broom. Heavy amounts of snow on roof can damage building making it unsafe to enter. In snow country, Roof Strengthening Kits are available for most Arrow Buildings for added protection against heavy snow accumulation.

Doors: Always keep the door tracks clear of dirt and other debris that prevent them from sliding easily. Lubricate door track annually with furniture polish or silicone spray. Keep doors closed and locked to prevent wind damage.

Fasteners: Use all washers supplied to protect against weather infiltration and to protect the metal from being scratched by screws. Regularly check your building for loose screws, bolts, nuts, etc. and retighten them as necessary.

Moisture: A plastic sheet (vapor barrier) placed under the entire floor area with good ventilation will reduce condensation.

Other Tips....

- Wash off inked part numbers on coated panels with soap and water.
- Silicone caulking may be used for watertight seals throughout the building.

Do not store swimming pool chemicals in your building. Combustibles and corrosives must be stored in air tight approved containers.

Keep this Owner's Manual and Assembly Instructions for future reference.

ACCESSORIES...

A6 WEB

ROOF STRENGTHENING (heavy snow load) KITS

Extra roof beams and gable braces designed for added protection against heavy snow accumulation. Increases the strength of your roof by 50%.

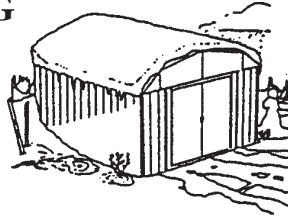

ANCHOR KITS

Model No. AK4

Anchor Kit contains heavy-duty steel augers, 60' (18m) of steel cable and 4 cable clamps. No digging or concrete pouring, just insert cable under roof, over roof beams, into augers and twist augers into the ground. For buildings larger than 10'x9', use 2 kits.

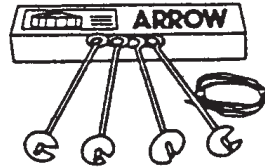

Model No. AK100

New concrete anchor system permits anchoring any size Arrow building directly to a concrete slab. Each kit contains heavy-duty, hot-dipped galvanized steel corner gussets and perimeter clips which fit over the floor frame and lag bolt into a concrete slab. Full assembly instructions and a 1/4" masonry drill bit are included.

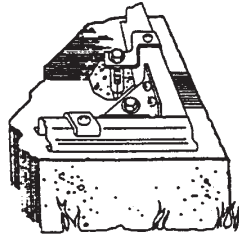

Model No. AK600

Earth Anchor Kit anchors any size Arrow building to the ground. Each kit contains heavy duty, hot-dipped galvanized steel corner gussets and 4 earth anchors.

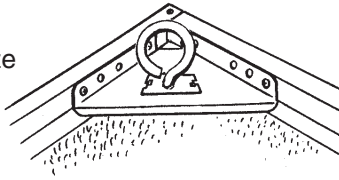

TOOL HANGING RACK

Model No. TH100

The perfect tool organizer. Twin 25 1/2" (65cm) steel channels plus five heavy-duty snap-in hangers and a small tool holder for screwdrivers, pliers, etc. Holders slide along channel for fully adjustable spacing. Great for garage, basement, or the back of any door. Fits all Arrow storage buildings.

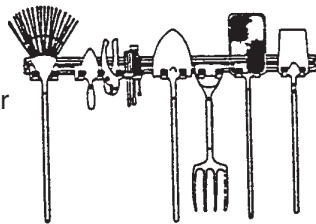

FLOOR FRAME KITS

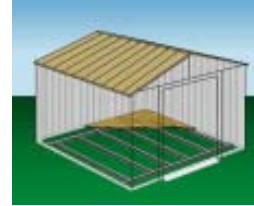

MODELS FB47410, FB5465, FB106-A
FB109-A and FB1014-A

A simple new floor frame system made of heavy-duty, hot-dipped galvanized steel. Use as foundation for plywood, sand or stone.

ATTIC KIT / WORKBENCH KIT

Heavy-duty galvanized steel bars that fit all 10' wide Arrow buildings. They install quickly and easily to help organize space and create more useable space as an attic or workbench. Will hold up to 250 lbs. (113kg) evenly distributed.

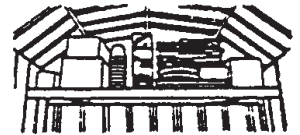

Model No.	Fits	Shipping Weight
AT101	10' Long, 250 lb. (113kg) load+ Fits all Arrow 10' wide buildings.	16 lbs. (7kg)

Must be drilled for use as workbench in Estator.
+ Even weight distribution.

SHELF UNITS

Heavy-duty, galvanized steel shelf units help organize storage space. They easily mount on the wall or sit on the floor. Fits all Arrow buildings.*

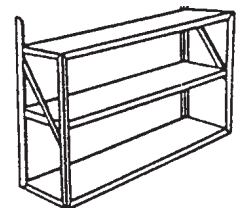
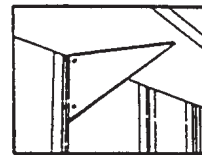
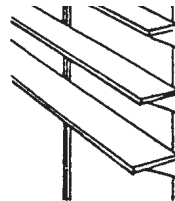

Model No. SS404

- Makes 8" to 12" (20-30cm) wide shelves in any length.
- Brackets, braces, hardware included. Lumber is not included.

Model No. SS900-A

- Grey color
- 3 shelves
- Holds up to 85 lbs. (38kg) (even weight distribution)

* Some drilling required to fit buildings without mid-wall bracing.

THIS
PAGE
WAS
LEFT
BLANK
INTENTIONALLY



THIS

PAGE

WAS

LEFT

BLANK

INTENTIONALLY

Foundation

A09

The Foundation For Your Building



OPTION 1: ARROW FLOOR FRAME KIT: (Order No. FB109-A or 68385-A)

Arrow has the best base for your building in this simple kit. It keeps stored items above the ground. This kit should be used with one of the following:

A. To support a plywood deck **B.** To be filled with sand. We recommend the combined use of

1. an **ARROW FLOOR FRAME KIT** and **2.** an **ARROW ANCHORING KIT** as an effective method of securing the building to the ground.

Allow 1 - 2 hours for construction.

OPTION 2: Wood Platform

If you decide to build your own foundation, be sure to select the appropriate materials.

These are the recommended materials for your foundation:

- 2 x 4's (5cm x 10cm) Pressure Treated Lumber
- 5/8" (1,5cm) 4 x 8 (122cm x 244cm) Plywood-exterior grade
- 10 & 4 penny Galvanized Nails
- Concrete Blocks (optional)

The platform should be level and flat (free of bumps, ridges etc.) to provide good support for the building. The necessary materials may be obtained from your local lumber yard.

To construct the foundation follow instructions and diagram.

Construct frame (using 10 penny galvanized nails)
Measure 16"/24" (40,6cm/61,0cm) sections to construct inside frame (see diagram)

Secure plywood to frame (using 4 penny galvanized nails)

Allow 6 - 7 hours for construction.

OPTION 3: Concrete Slab

The slab should be at least 3" to 4" (8-10cm) thick. It must be level and flat to provide good support for the frame.

The following are the recommended materials for your foundation.

- 1 x 4's (2,5cm x 10cm) (will be removed once the concrete cures)
- Concrete
- Sheet of 6 mil plastic
- We recommend for a proper strength concrete to use a mix of:
1 part cement ● 3 parts pea sized gravel ● 2 1/2 parts clean sand

Prepare the Site/Construct a Foundation

1. Dig a square, 6" (15cm) deep into the ground (remove grass).
2. Fill up to 4" (10cm) in the square with gravel and tamp firm.
3. Cover gravel with a sheet of 6 mil plastic.
4. Construct a wood frame using four planks of 1x4 (2,5cm x 10cm) lumber.
5. Pour in concrete to fill in the hole and the frame giving a total of 4" (8-10cm) thick concrete. Be sure surface is level.

Allow 3 - 5 hours for construction and a week for concrete curing time.

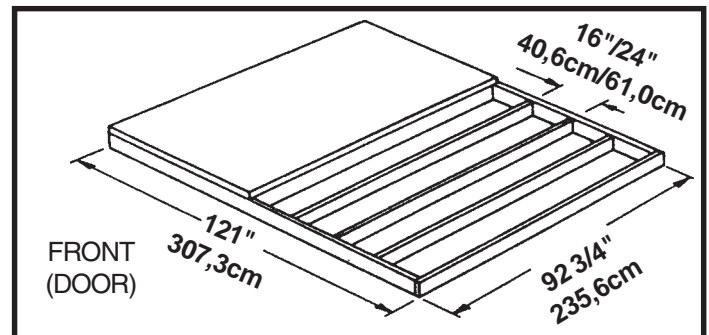

Note: Platform/Slab will extend 9/16" (1,4cm) beyond floor frame on all four sides. Seal this 9/16" of wood with a roofing cement (not included), or bevel this 9/16" of concrete when pouring, for good water drainage.

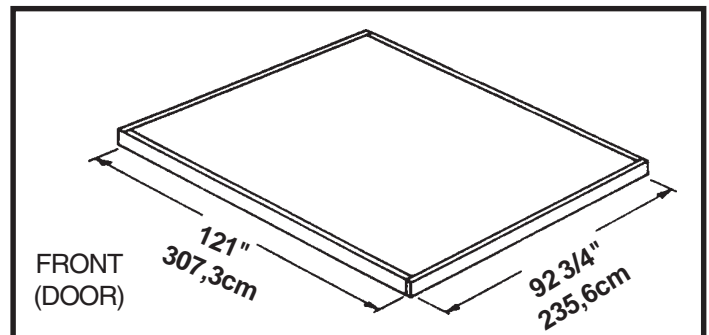

Note: Finished Slab dimensions, with lumber removed.

Anchoring

A10

Anchoring Down The Building

It is important that the entire floor frame be anchored after the building is erected.

Below are recommended ways of anchoring.

Arrow Anchoring Kit: (Model No. AK4 or 60298)

Recommended for use with **any** suggested **base**.

Contains: 4 Anchors with Cable, Clamps and installation instruction.

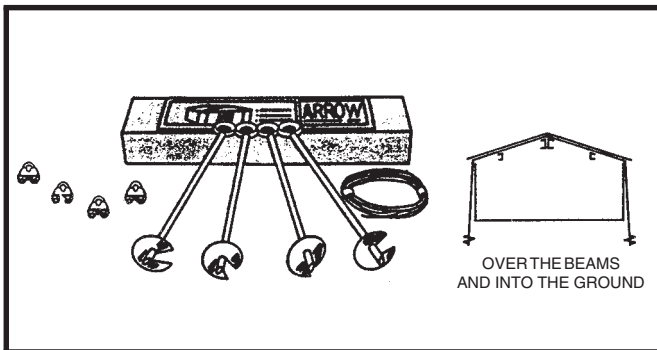

Anchoring into Wood/Post:

Use 1/4" Wood Screws. There are 1/4" (0,63cm) dia. holes provided in the frames for proper anchoring.

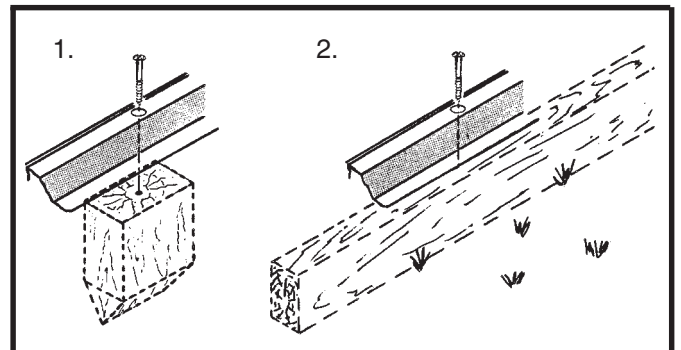

Arrow Anchoring Kit: (Model No. AK100 or 68383)

Recommended for use with the **concrete** foundation.

Contains: Corner gussets, perimeter clips, hardware, 1/4" masonry drill bit and installation instruction.

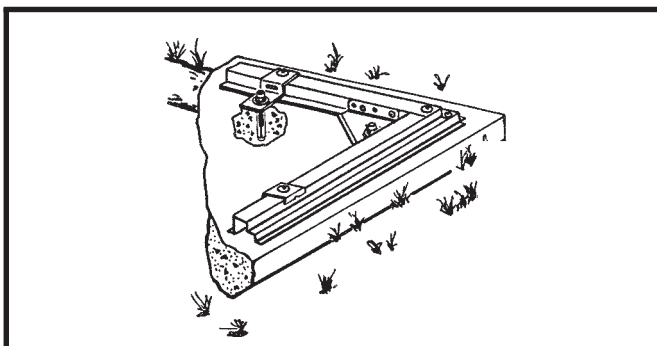

Anchoring into Concrete:

1. For poured concrete slab or footing or patio blocks:

Use 1/4" x 2" Lag Screws.

2. For Anchor Post of Concrete poured after building is erected: Use 1/4" x 6" Lag Screws.

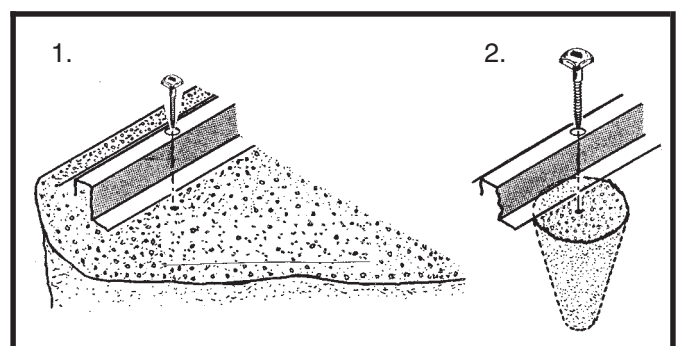

Hardware

Y11

Remove from bag of screws
and save for the last step



65103
#8-32 Hex Nut (165)



65900A
#10Bx1/2" Black Screw (8)
(Packed with Screws)



65923
#8-32x3/8" Bolt (151)



65004
#8Ax5/16" Screw (320)

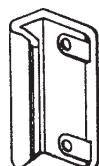

66045
Handle (2)

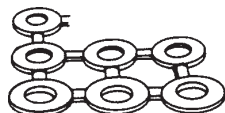

66646
Washer (216)
(6 sheets of 40)



65109
#8-32 Acorn Nut (14)
(Packed with Screws)

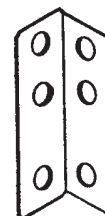

5971
Roof Beam Bracket (4)

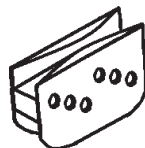

66769
Door Slide (4)

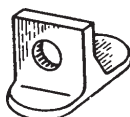

66382
Lower Door Guide (4)

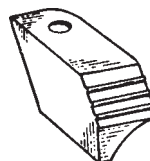

66183
Roof Trim Cap
(2 right & 2 left)



67468 (Arrow Logo)
Peak Cap (2)

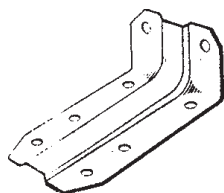

6228
Track Support (2)

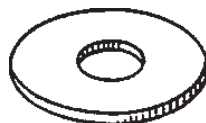

65020
Door Washer (14)
(Packed with Screws)

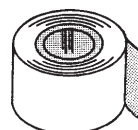

67293
Weather Stripping (1)



65958
#8-32x7/8" Bolt (14)
(Packed with Screws)

Parts List

Y12

Assembly Key No.	Part Number	Part Description	Quantity in Carton	Check List
1	8934	Ramp	1	
2	9367	Front Floor Frame	2	
3	8936	Rear Floor Frame	2	
4	9338	Right Rear Wall Angle	1	
5	9366	Door Track	2	
6	5287	Splice Post	3	
7	9339	Left Rear Wall Angle	1	
8	6001	Left Gable	2	
9	6000	Right Gable	2	
10	9203	Side Floor Frame	4	
11	5288	Corner Post	4	
12	9341	Left Side Wall Angle	2	
13	9340	Right Side Wall Angle	2	
14	9365	Front Wall Channel	2	
15	7311	Door Jamb	2	
16	9344	Siding Stud	6	
17	8584	Side Siding	12	
18	7483	Roof Panel	4	
19	8736	Rear Siding	6	
20	8486	Ridge Cap	1	
21	8737	Front Siding	6	
22	10470	Roof Beam	8	
23	8468	Right Roof Panel	2	
24	6529	Roof Panel	2	
25	8469	Left Roof Panel	2	
26	8840	Ridge Cap	1	
27	8485	Left Side Roof Trim	2	
28	8836	Right Side Roof Trim	2	
29	10493	Right Door	1	
30	10493	Left Door	1	
31	10501	Horizontal Door Brace	4	
32	67731	Foam Board	2	
33	8641	Vertical Door Brace	2	
34	6635	Gable Brace	2	
35	6403	Door Track Splice	1	

Assembly by Key No.

Y13

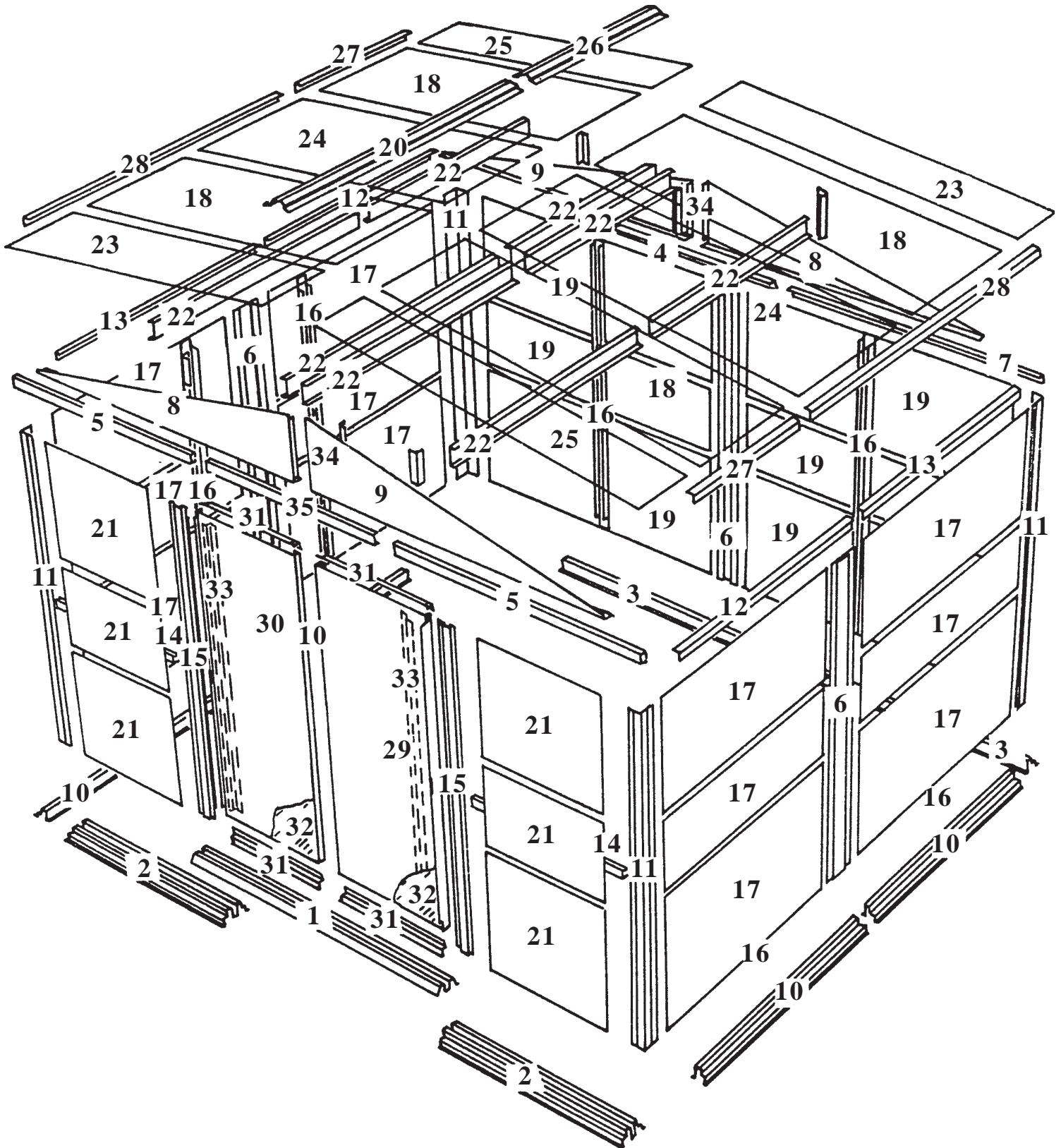

Step 1

G14

● Parts Needed For ● Floor Frame Assemblies

- 8934 Ramp (1)
- 9367 Front Floor Frame (2)
- 8936 Rear Floor Frame (2)
- 9203 Side Floor Frame (4)

The front floor frame is made up of three pieces. The side floor frames and the rear floor frame are made up of two pieces. The holes in these pieces will align when the pieces are positioned with correct amount of overlap. The illustrations below show the proper overall length for the sides, rear and front. Proceed as follows:

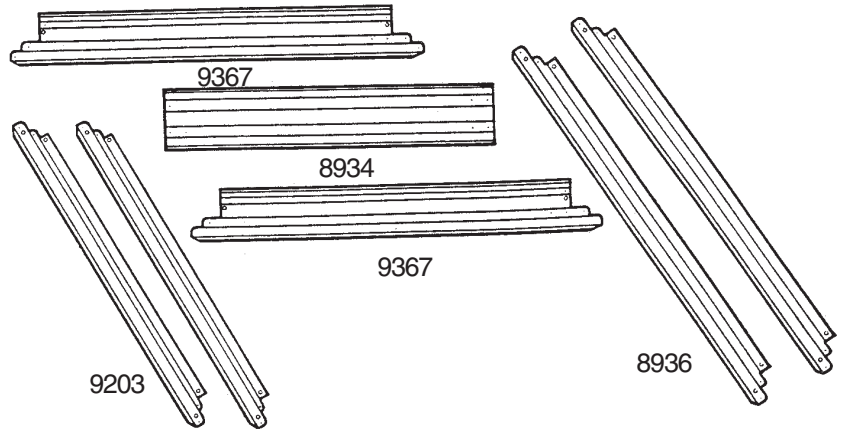

1 Place the **front floor frames** as shown. Center the **ramp**, with drain holes facing outside, on top of the two front floor frames. Join the frames by inserting eight screws.

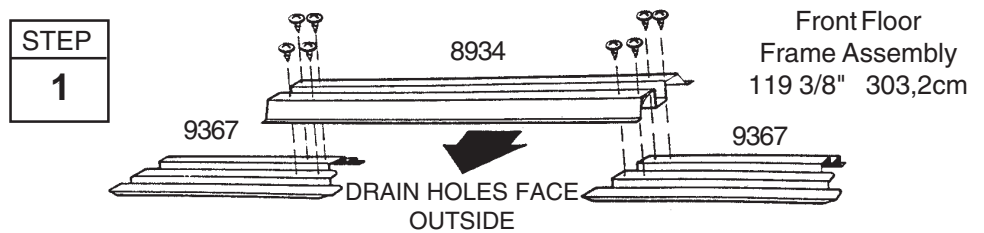

2 Overlap the **side floor frames** and the **rear floor frames** as shown. The holes in these pieces will align when the pieces are positioned with correct amount of overlap. See the illustrations below for the proper overall length of the side and rear floor frames. Join the frames by inserting four/five bolts into each frame set as shown.

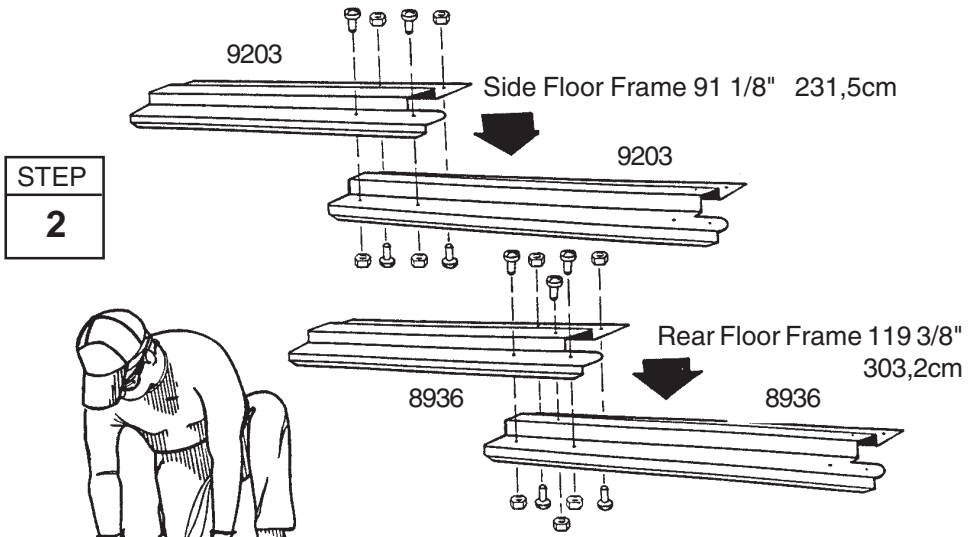

3 Double check the length of each and set these pieces aside for later use.

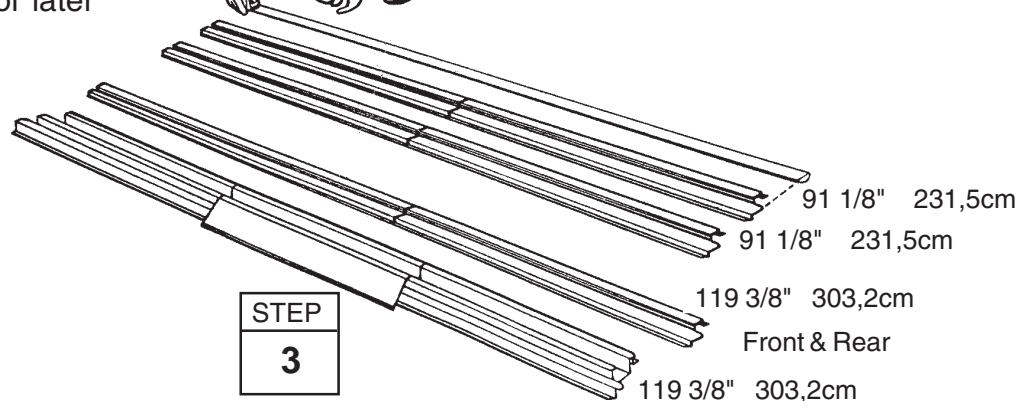

Step 2

Y15

● Parts Needed For ● Frame Assemblies

- 9338 Right Rear Wall Angle (1)
- 9339 Left Rear Wall Angle (1)
- 9340 Right Side Wall Angle (2)
- 9341 Left Side Wall Angle (2)

The main frame pieces reinforce the walls. These piece will later be installed at the top edge of the side walls and the rear wall. Proceed as follows:

1 Overlap the **right and left rear wall angle** pieces as shown in the figure and fasten them together with *one bolt in the center hole*.

2 Make two **right and left side wall angles** by overlapping the right and left side wall angle pieces as shown. Fasten each set together with *one bolt in the center hole*.

3 Set the assemblies aside. You will use them later.

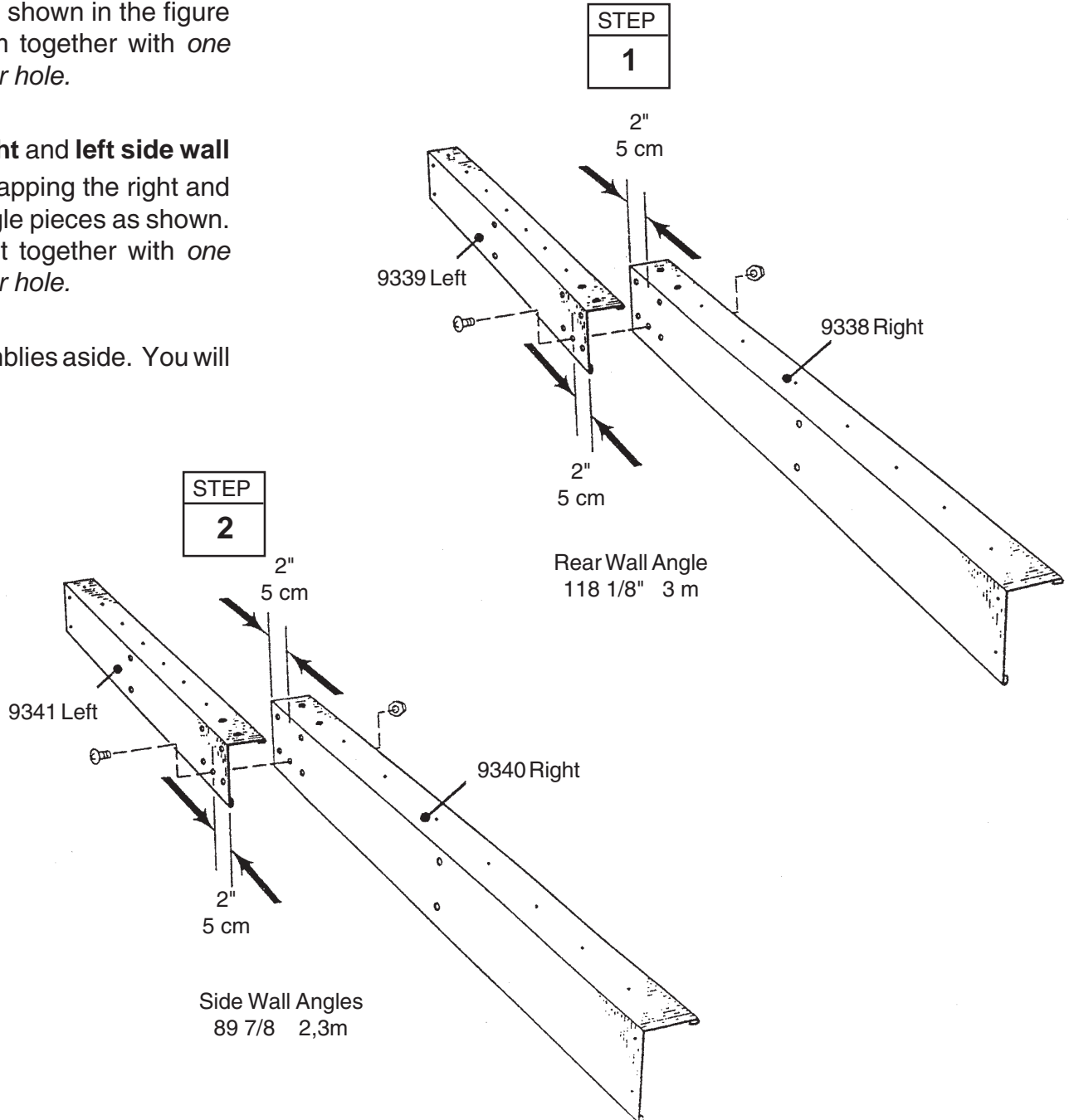

Step 3

D16

● Parts Needed For ● Roof Beam Assemblies

● 10470 Roof Beam (8)

The roof beams join the two gables and support the roof panels. The main roof beam is made up of four pieces overlapped back to back at the center. The left and right roof beam assemblies are made up of two pieces. **Hint:** These pieces are force-fitted, so you may have to press hard to join them together.

1 Place the end of one roof beam inside a second roof beam so that the six holes in each piece align. Make four sets of roof beams by repeating this procedure. ***Do not insert bolts yet.***

2 Take two of the pressed-together roof beams and join them as shown to form the main roof beam assembly. Hold the assembly together and fasten with 14 bolts. Build ***only one*** Doubled Beam Assembly.

3 Fasten the other two pressed-together roof beams with eight bolts to make the left and right roof beam assemblies.

4 Set these pieces aside for later assembly.

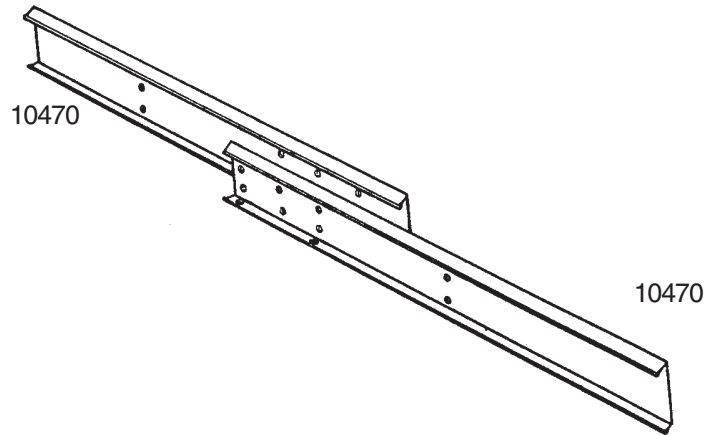

Roof Beam 91 7/8" 233,4cm

STEP
1

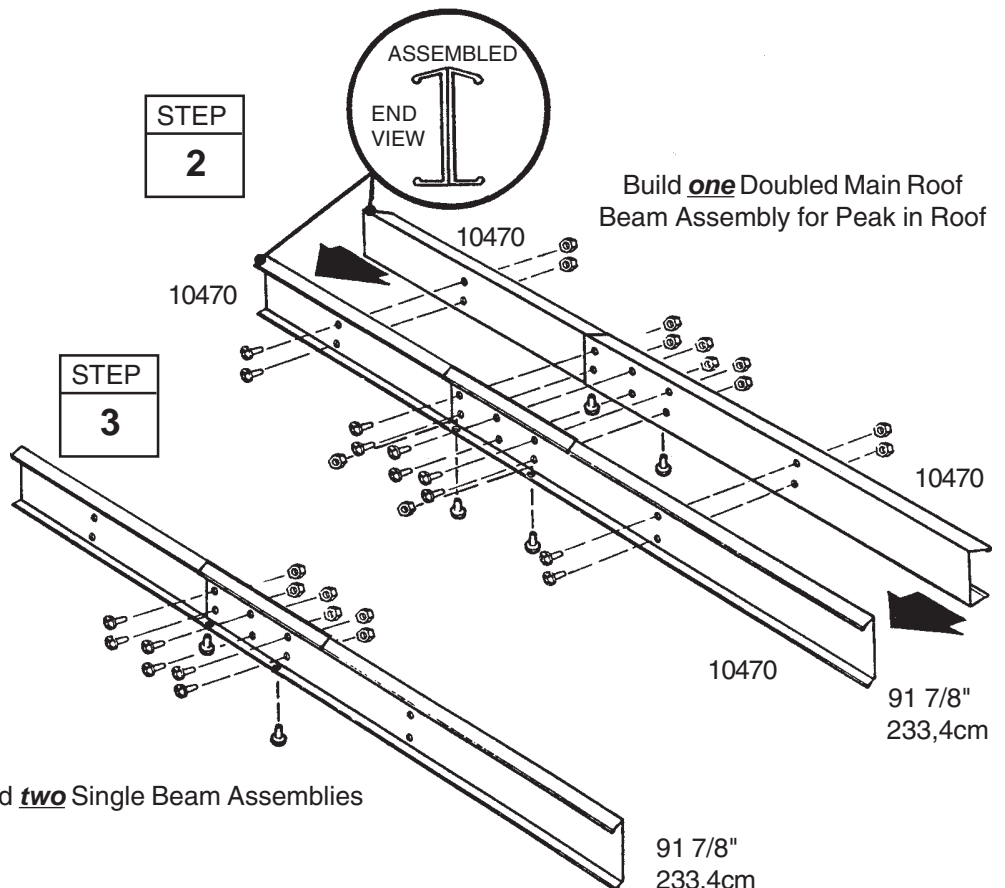
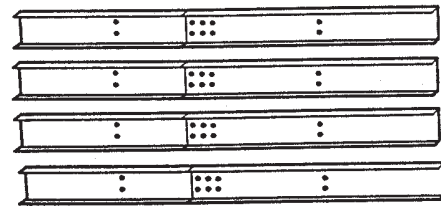

Step 4

A17

● Parts Needed For ● Door Track Assembly

- 6403 Door Track Splice (1)
- 9366 Door Track (2)

The door track assembly supports the sliding doors and reinforces the front wall. It is made up of three pieces.

1 Using the **door track splice**, (painted), join the **door track** (galvanized) pieces end-to-end as shown.

2 Insert four screws from the *under-side only*.

Hint: The holes in the top side of the door track assembly are for fastening the gable to the top of the front wall in a later step.

3 Position **door slides** onto the legs, from the end of door track assembly, as shown in the end view.

4 Set this piece aside for later use.

NOTE:
Door Track Splice (painted part)

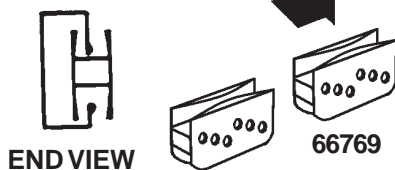
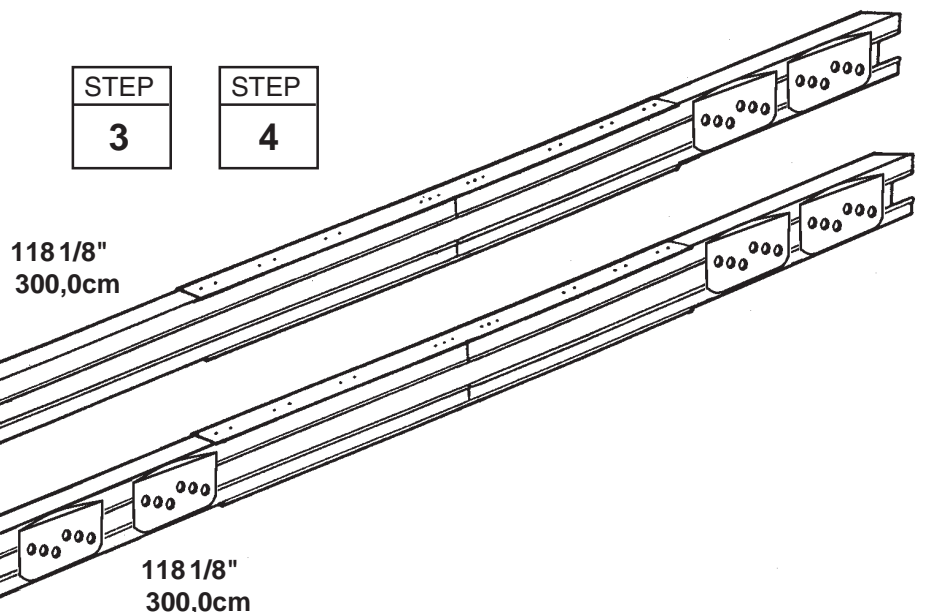
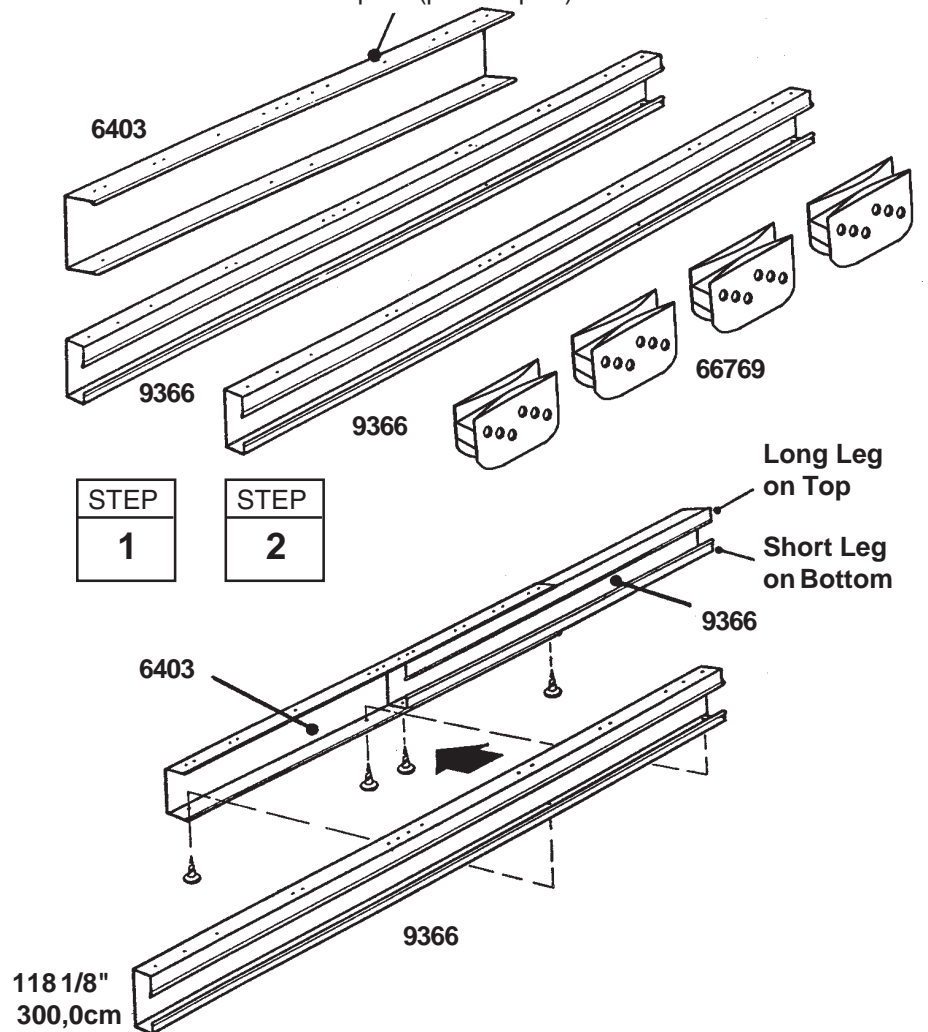

Step 5

G18

● Parts Needed For ● Floor Frame

- Front Floor Assembly (1)
- Side Floor Assembly (2)
- Rear Floor Assembly (1)

1 Assemble the four corners of the floor frame using two screws at each corner as shown. At the front corners fasten bolts through from the bottom with nuts on top.

STEP
1

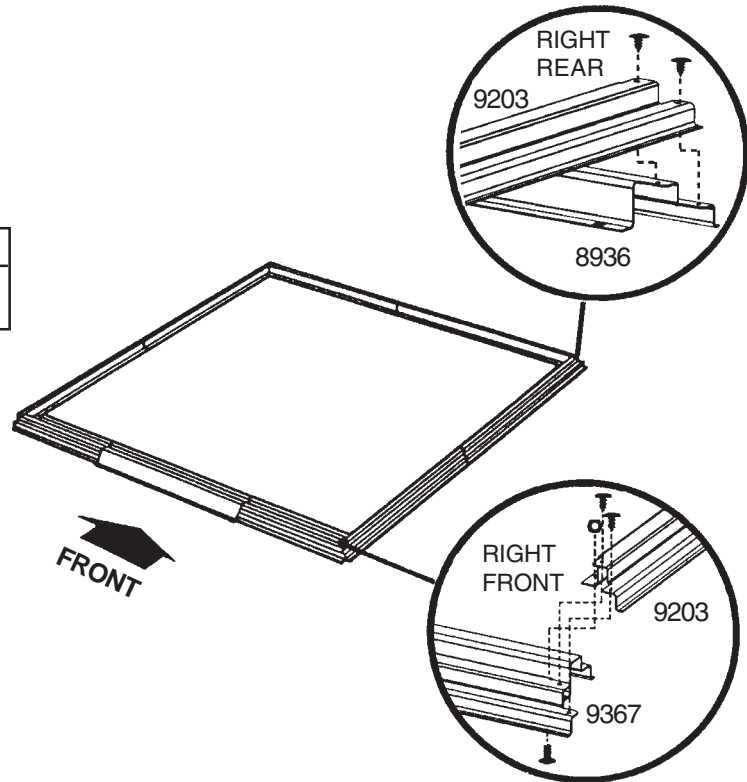

2 Measure the floor frame diagonally. When the diagonal measurements are equal, the floor frame is square.

When Diagonal Measurements are Equal the Floor Frame is Square.

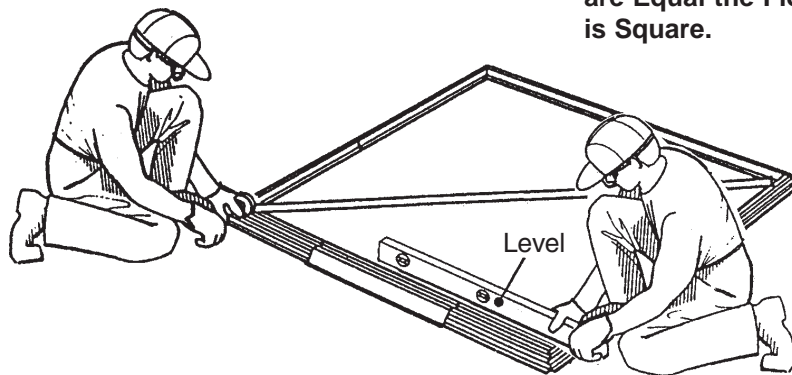

STEP
2

NOTE

If using a wood platform or concrete slab do not fasten the floor frames to your base at this time. You will anchor the building after it is erected.

NOTE

If you have purchased a Floor Frame Kit you need to install it at this time.

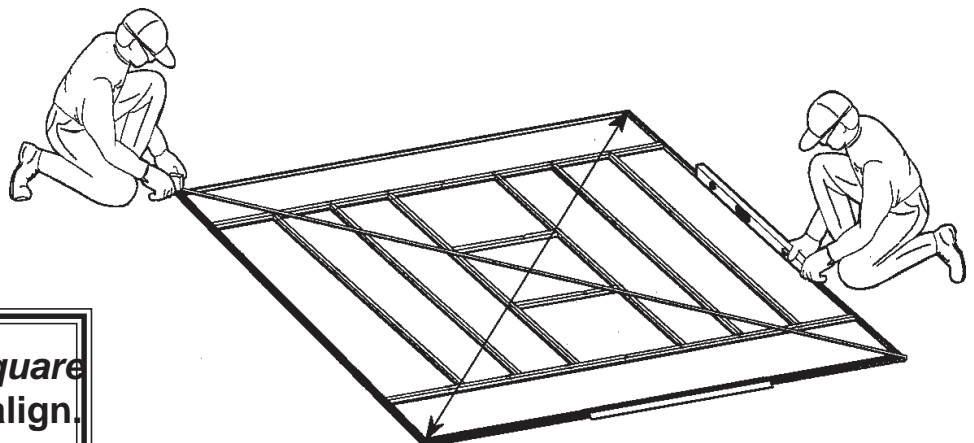

The floor frame *must be square and level* or holes will not align.

Step 6

Y19

● Parts Needed For ● Posts/Top Frames

- 5288 Corner Post (4)
- Door Track Assembly (1)
- Rear Wall Angle Assembly (1)
- Side Wall Angle Assembly (2)

NOTE

The remainder of the building assembly requires many hours and more than one person. Do not continue beyond this point if you do not have enough time to complete the assembly today. A partially assembled building can be severely damaged by light winds.

The top frame pieces give rigidity to the side walls and provide a surface for attaching the gables which support the roof.

1 Position **corner posts** at the corner of the floor frame as shown. Fasten the corner post to the floor frame with two screws.

Support the corner posts with stakes or other devices until door jambs are attached.

2 Fasten the **door track assembly** (holes on top) behind the top of the front corner posts using 1 screw in each corner. See the figure.

3 Fasten the **rear wall angle assembly** behind the top of the rear posts using 2 screws in each post.

4 Fasten the **side wall angles** behind the top of the side posts using 2 screws in each corner. Side wall angles overlap rear wall angle in corners.

The floor frame *must be square and level* or holes will not align.

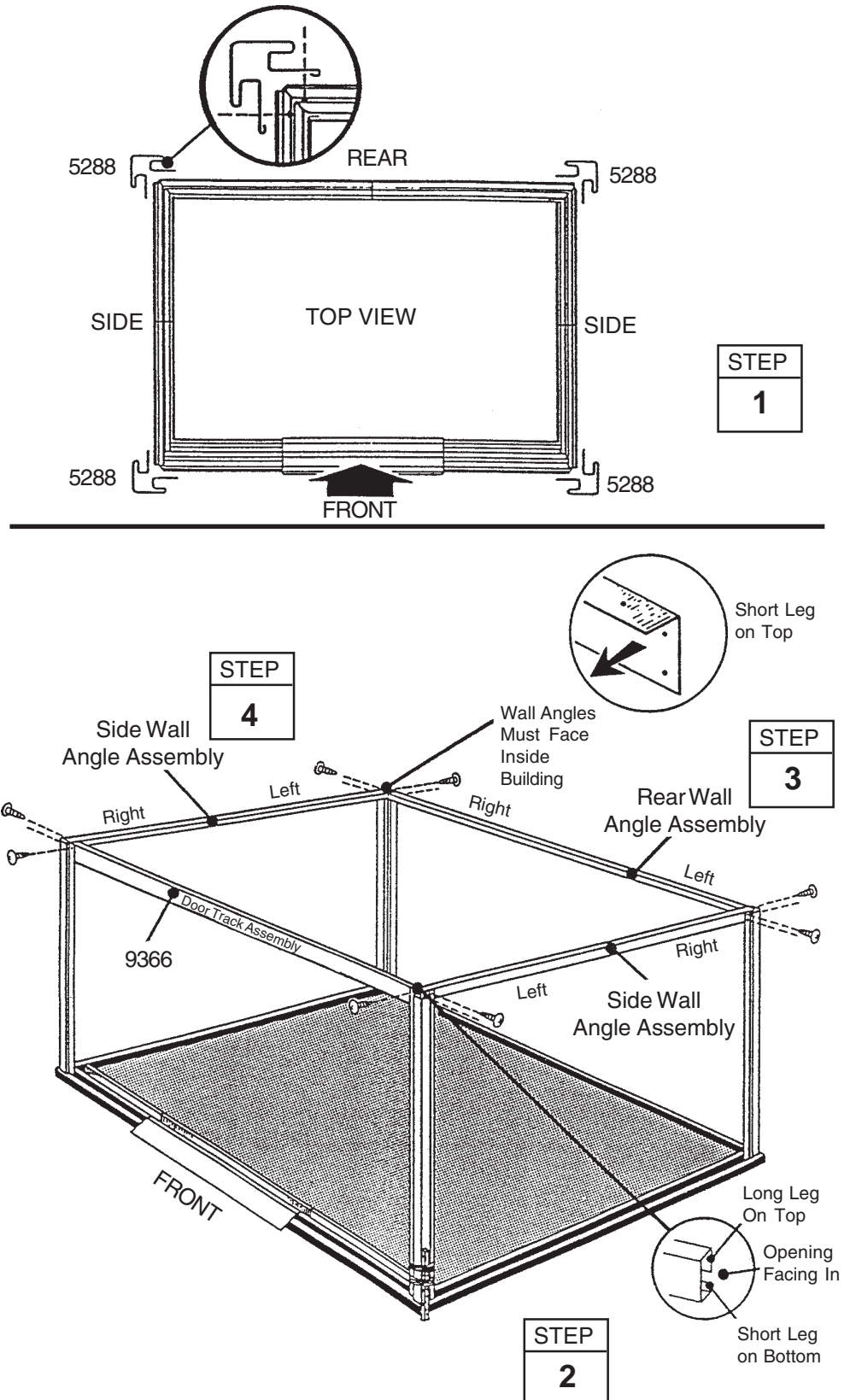

Step 7

Y20

● Parts Needed For ● Splice Post/Door Jamb

- 5287 Splice Post (3)
- 7311 Door Jamb (2)

STEP

1

The door jambs reinforce the door opening and provide an attractive trim. The splice post supports the wall.

1 Position **splice post** at the center of the rear wall and fasten using 4 bolts and nuts into rear wall angle and 2 screws into rear floor frame.

Hint: Measure or count holes to determine if post is centered on angle.

2 Fasten splice posts to the sides of building in the same manner.

3 Fasten the top of the **door jambs** to the door track with 2 screws. Do the same for the bottom into frame. Notched edge faces toward center of building.

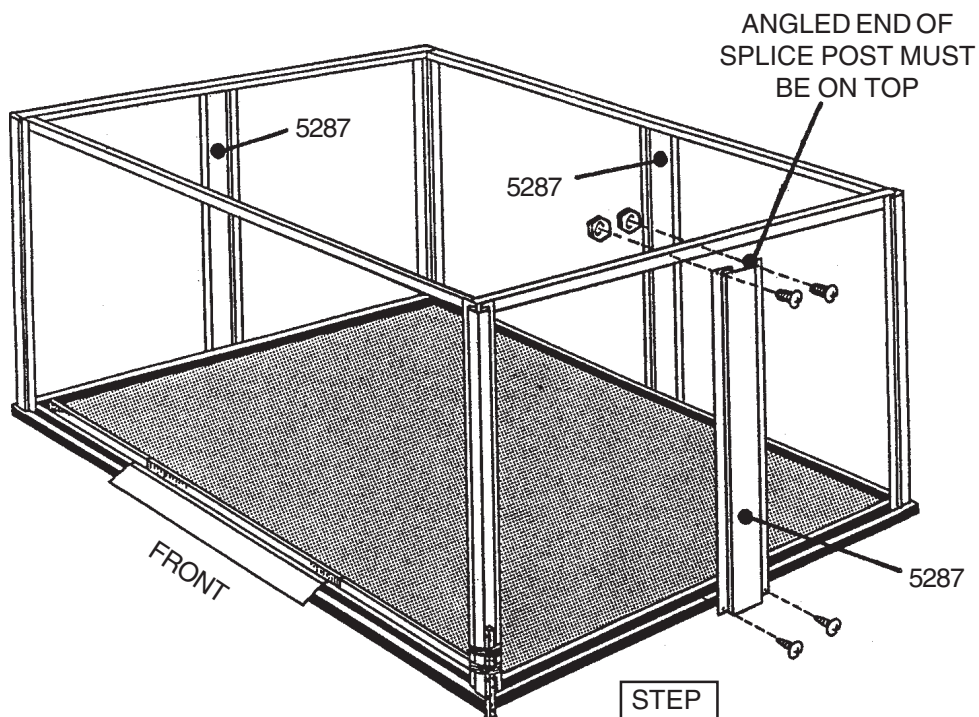

STEP

2

NOTCHED EDGE
MUST FACE CENTER
OF BUILDING

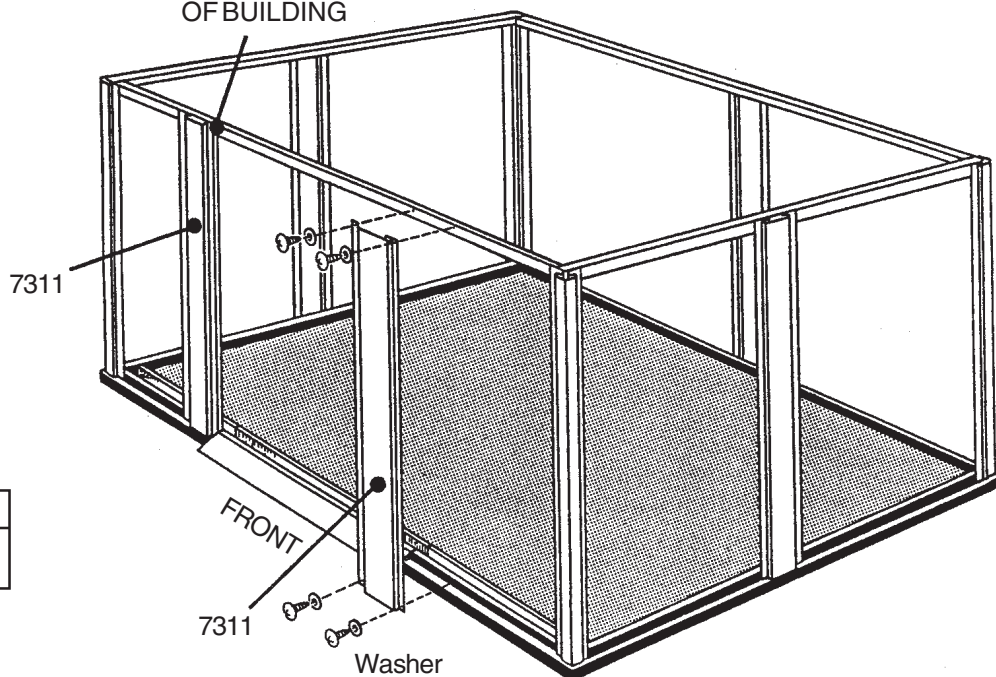

STEP

3

Step 8

Y21

● Parts Needed For ● Studs/Front Channel

- 9344 Siding Stud (6)
- 9365 Front Wall Channel (2)

The studs provide a surface for attaching the siding panels.

1 Following dimensions, measuring from the ends of angles, place a **stud** between each corner and splice post. Position stud inside top angle and fasten with a screw at the lower hole.

2 Rest bottom tab (large hole) outside floor frame. Do not fasten tab at this time. Repeat procedure for the remaining studs around the building.

3 Place **front wall channel** into position behind corner post and door jamb. Fasten using three screws.

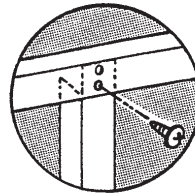

FASTEN STUD AT LOWER HOLE

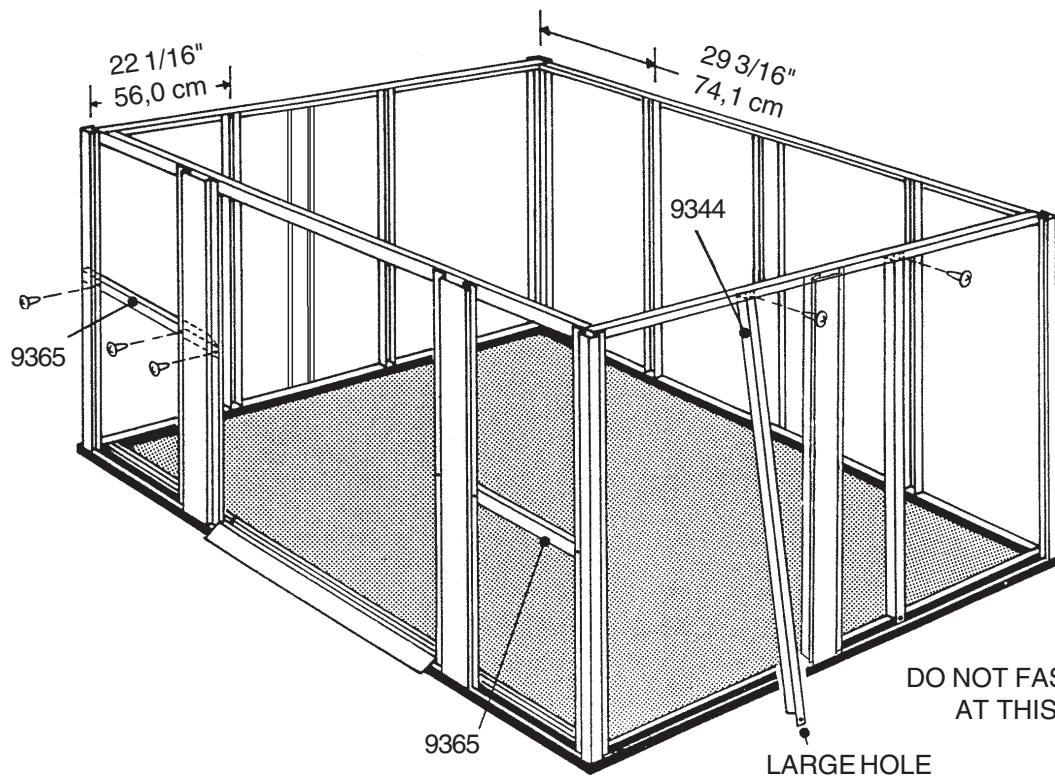

Step 9

Y22

● Parts Needed For ● Side Siding

● 8584 Side Siding (12)

Each screw in the wall requires a washer.

1 Slide **side siding** into channels of corner and splice posts, flat edge upward, bottom edge down resting on floor frame. Always follow this pattern. Fasten bottom edge and tab of stud to floor frame using screws. Fasten center to stud with screws. Do not fasten flat edge yet.

2 Install **side siding** as before. Note how the slot in bottom edge must overlap flat edge of last siding. Fasten both siding panels to stud at this overlap.

3 Install **side siding** to the top as before.

4 From inside building, fasten siding to corner posts and splice post using screws.

5 Repeat steps 1 through 4 for opposite side of building.

NOTE

Be careful to install the correct panel in each position as shown.

The floor frame must be square and level or holes will not align.

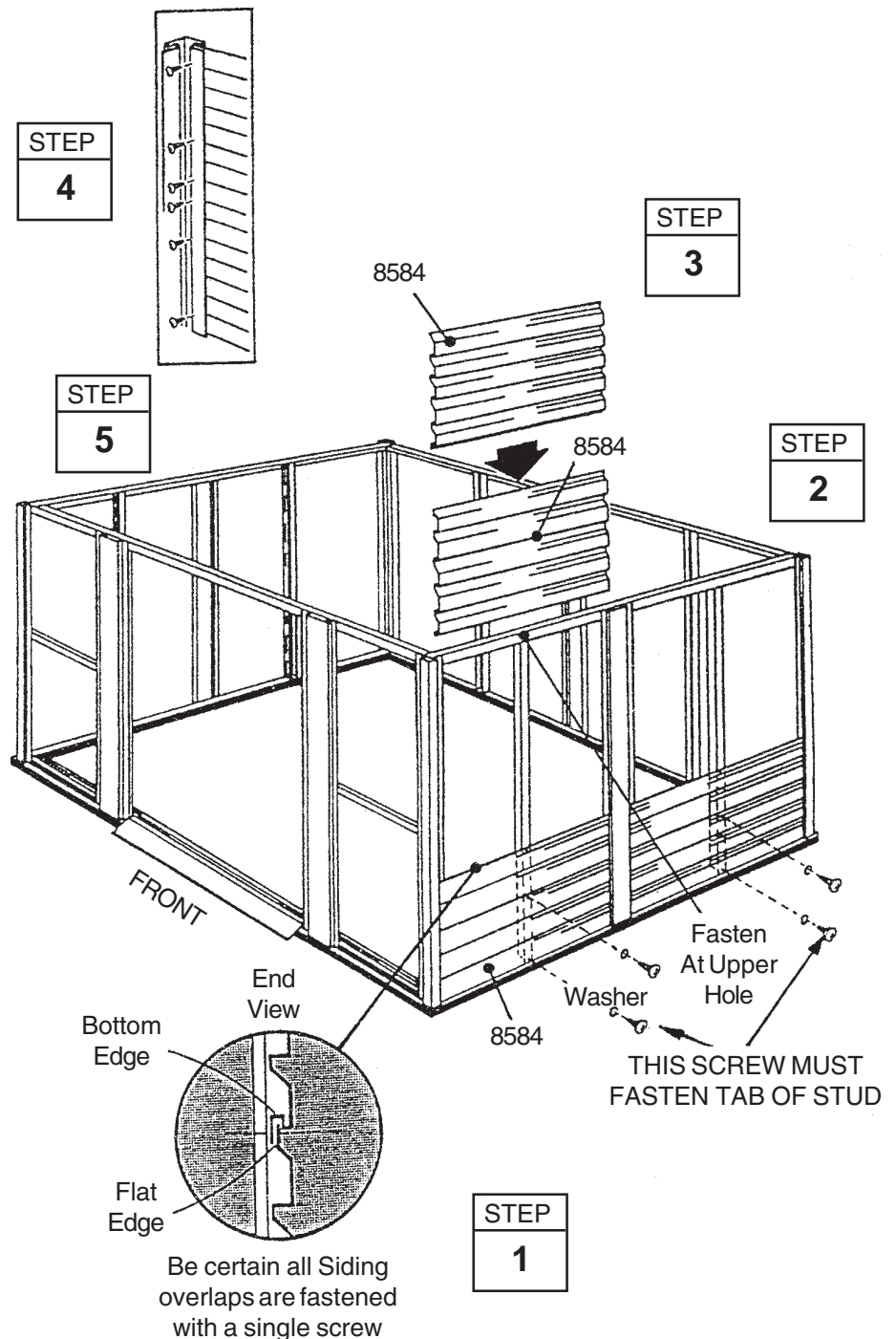

Step 10

Y23

● Parts Needed For ● Rear/Front Siding

- 8736 Rear Siding (6)
- 8737 Front Siding (6)

1 Slide **rear siding** into channel of corner and splice posts fastening to rear frame as shown in previous step 9.

2 Install **rear siding** to complete each section of rear wall. Fasten top center of last siding to rear angle.

3 Slide **front siding** into channels of corner post and door jamb. This siding is fastened from the inside, using screws into post and jamb.

4 Install **front siding** to complete both front sections.

STEP
1

STEP
2

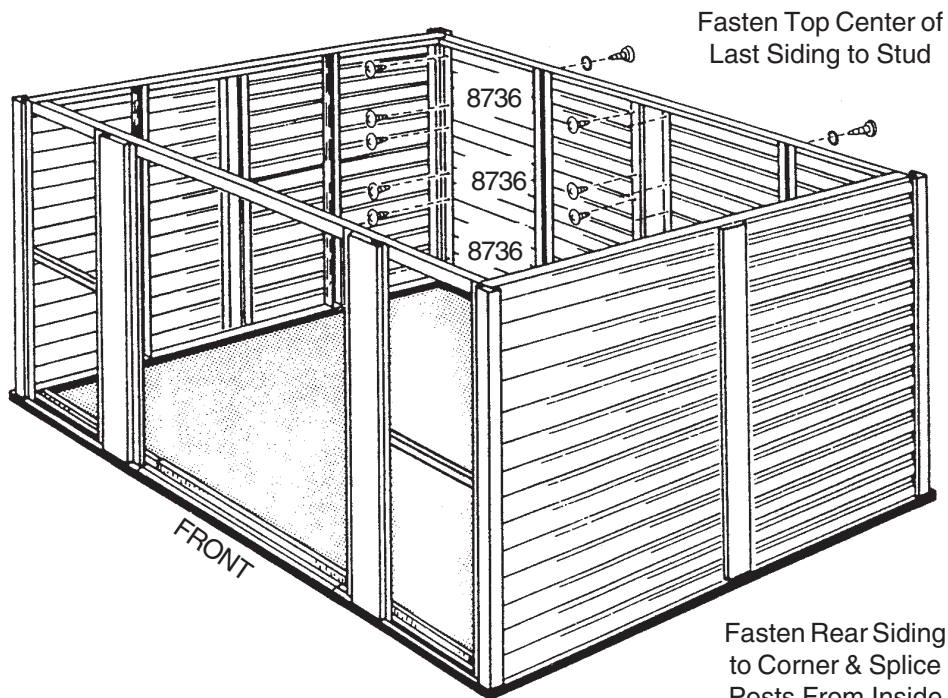

Fasten Top Center of Last Siding to Stud

Fasten Rear Siding to Corner & Splice Posts From Inside

STEP
3

STEP
4

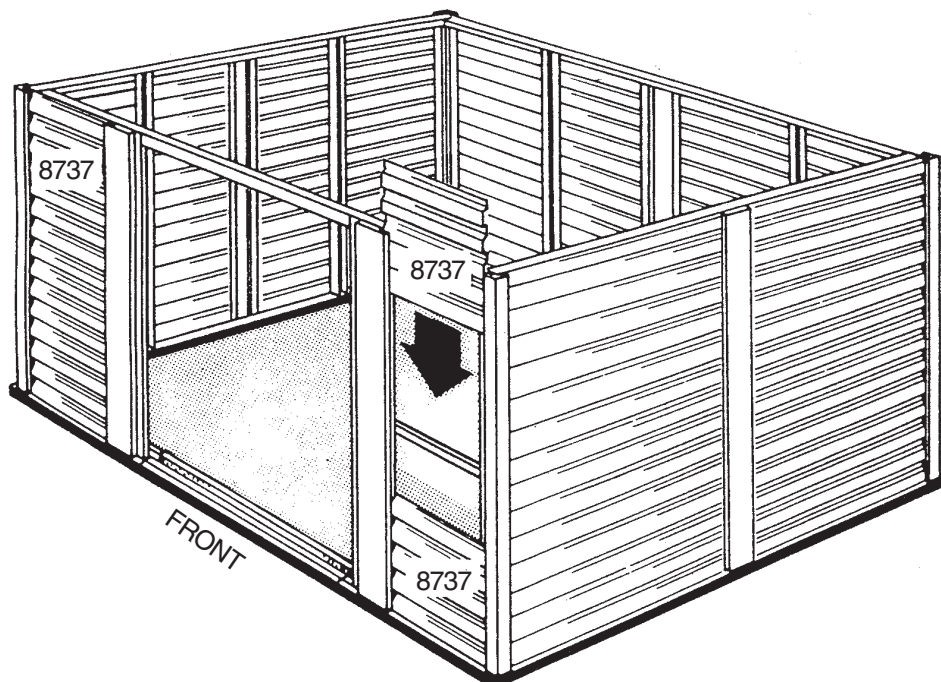

Front Panels Fasten at Corners & Door Jamb from the Inside

Step 11

Y24

● Parts Needed For ● Gable Assemblies

- 6000 Right Gable (2)
- 6001 Left Gable (2)
- 5971 Roof Beam Bracket (4)

The gables go on top of the front and rear walls to support the roof beams.

NOTE

The gables are packed nested together and might be mistaken as one piece. Carefully separate them before continuing.

1 Attach the four **roof beam brackets** to the gables using two bolts, washers and nuts.

NOTE

Mounting leg of bracket must face toward center of gable and holes closest together must be on top

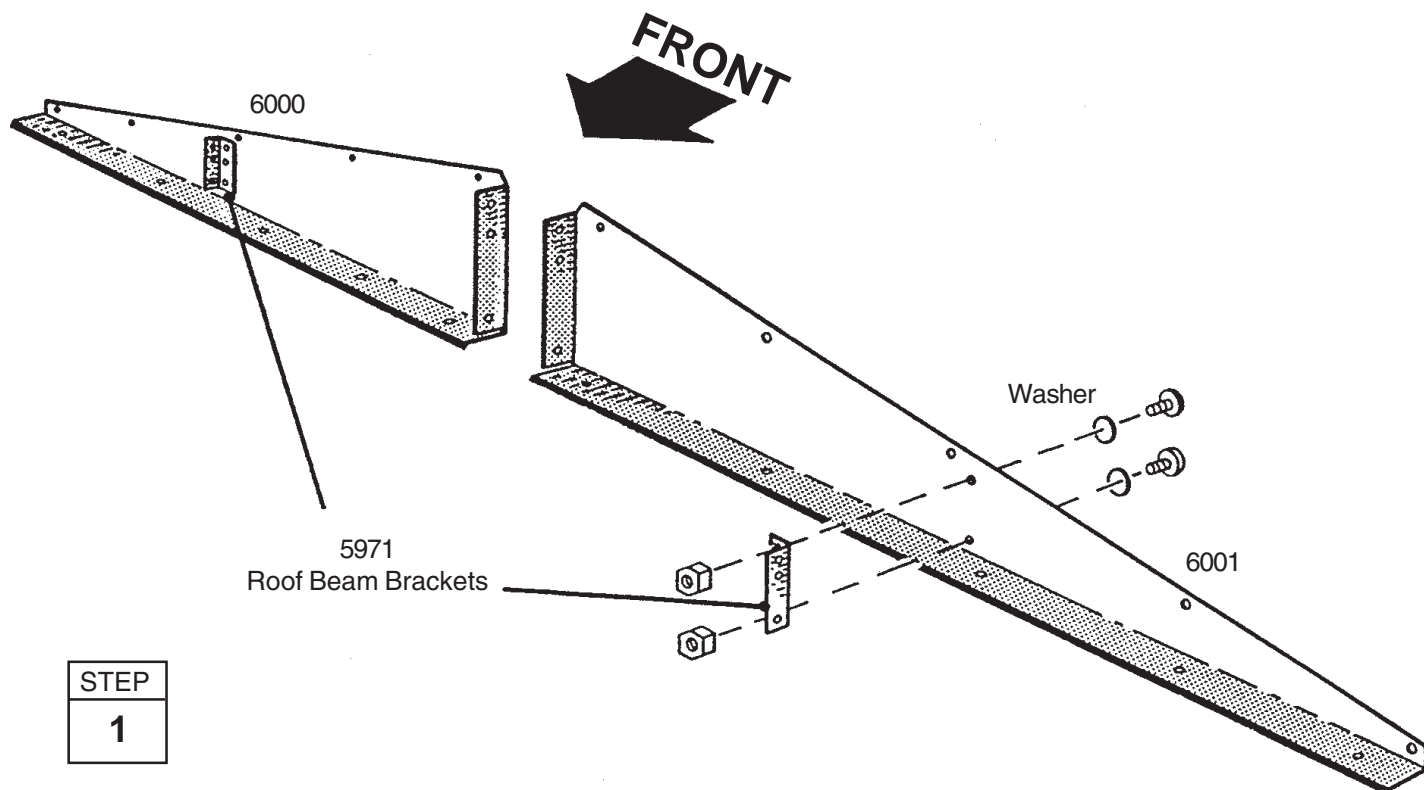

STEP

1

Step 12

X25

● Parts Needed For ● Gables/Braces

- Left Gable Assemblies (2)
- Right Gable Assemblies (2)
- 6635 Gable Brace (2)

1 Lift and fasten a right and left gable, under angle at corner, to the rear wall angle with screws.

Hint: On the rear gable, use a bolt and nut at the overlapping rear wall angle. On the front gable, leave out 2 screws closest to center gable leg.

2 Join the **left** and **right gables** together with a **gable brace** using a bolt in the bottom hole *only*.

3 Repeat Steps 1 & 2 for the door track on the front of building, except for the **track supports**, fasten as shown.

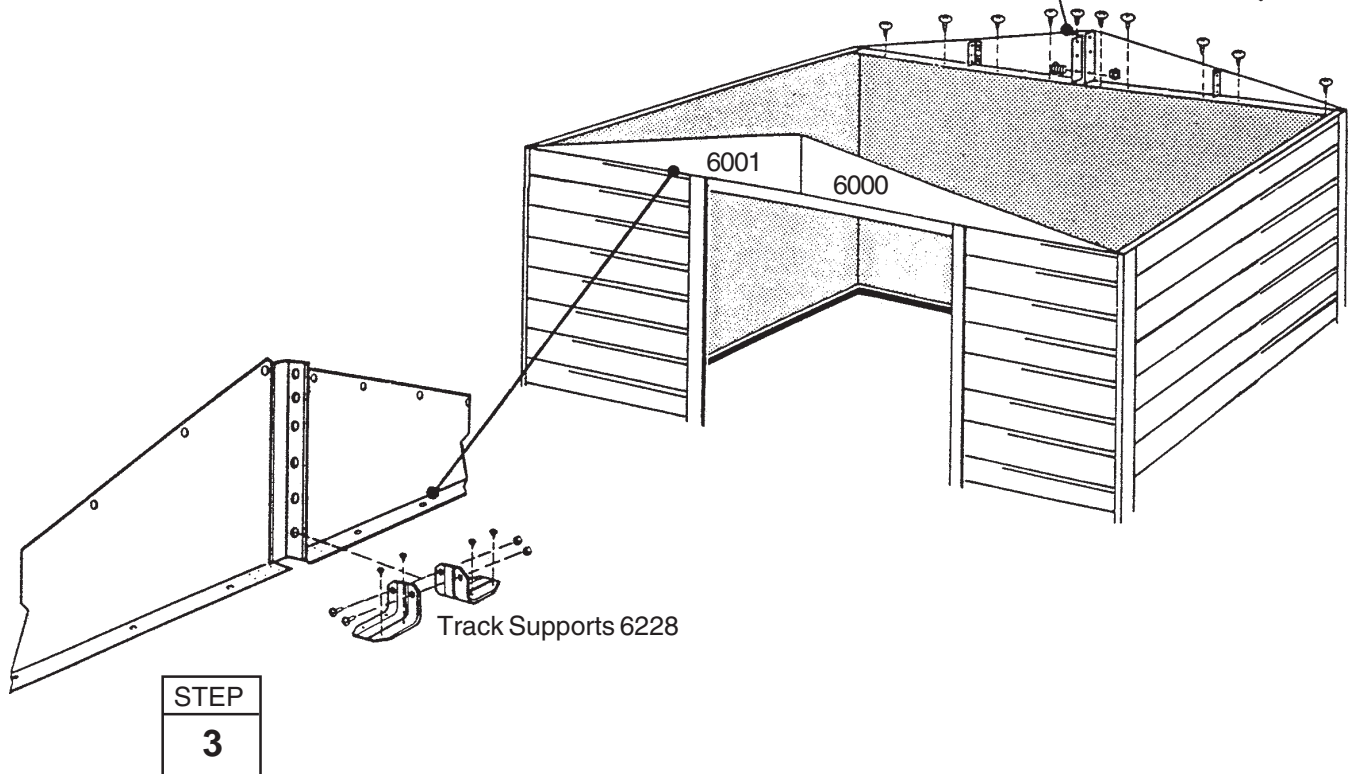
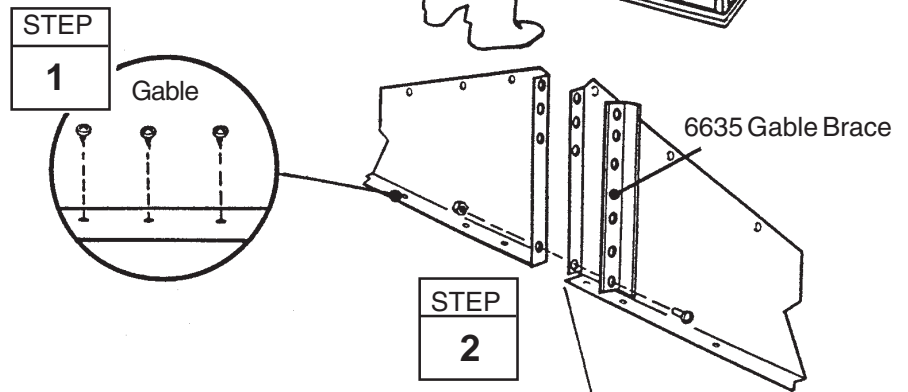

Step 13

Y26

● Parts Needed For ● Roof Beams

- Main Roof Beam (1)
- Single Roof Beam (2)

1 Spread the two halves of the **main roof beam** and fasten the roof beam to the gable brace of the front gable.

2 Fasten the other end of the main roof beam to the gable brace of the rear gable.

3 Fasten the **single roof beams**, *small holes on top*, as shown using bolts.

STEP
3

Single Roof Beam Assembly

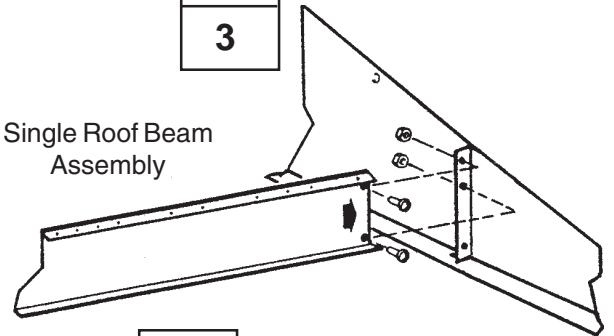

STEP
2

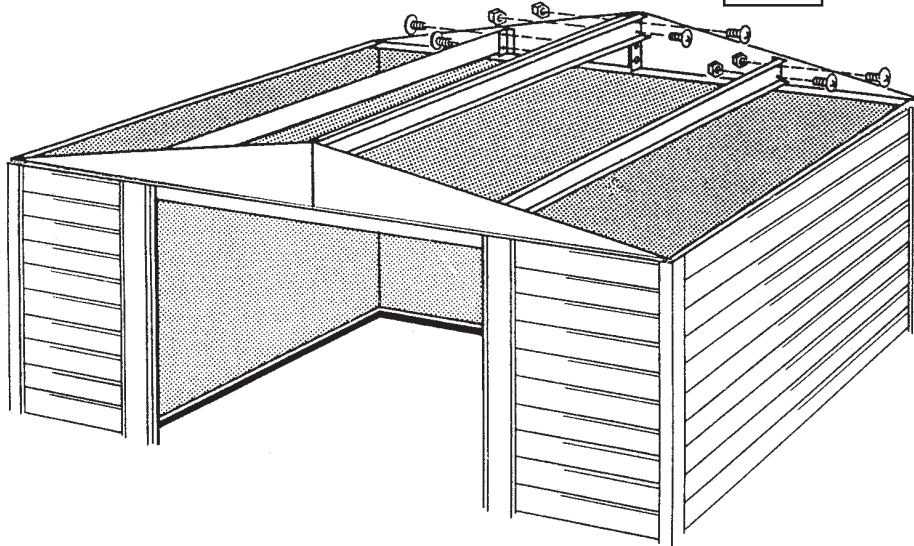

Spread Two Halves of Roof Beams

STEP
1

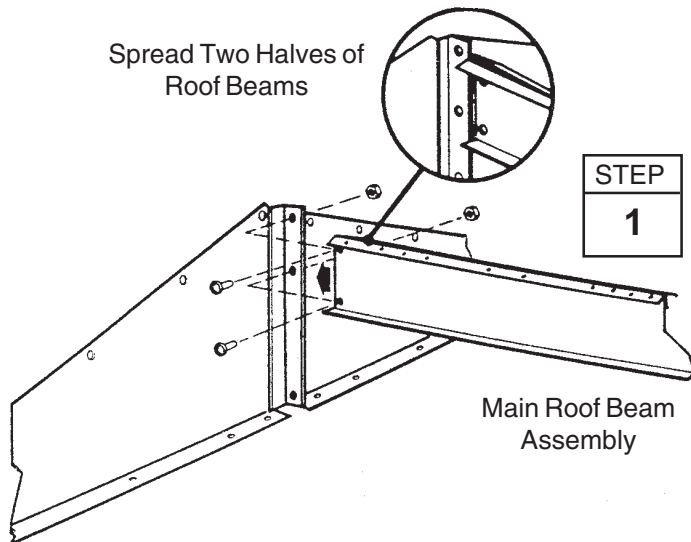

Step 14

Y27

● Parts Needed For ● Right Roof Panel

● 8468 Right Roof Panel (1)

Installing the roof panels is best done with a step ladder. Begin installing roof panels at the back right corner of the building. Each screw and bolt in the roof requires a washer.

NOTE

Measure the building diagonally again and make adjustments to make sure the building is square and level. This will make the roof panels fit better, and holes will align.

NOTE

If a **Roof Beef-Up Kit** was purchased, assemble prior to attaching the roof panels.

1 Locate the roof panels by their numbers. *Note the sequence and position they are to be installed.*

2 Position the **right roof panel** at the back right corner and fasten to the gable with 5 bolts and nuts and roof beams using 2 screws. *Do not fasten the lower end of the panel to the side wall angle at this time.*

Hint: Attach fasteners in order shown in diagram.

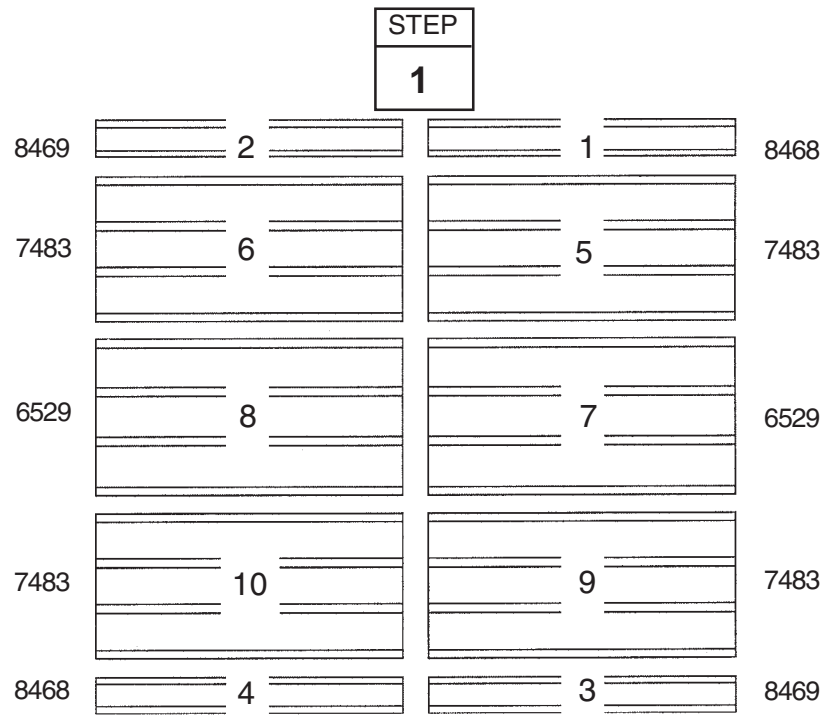

FRONT

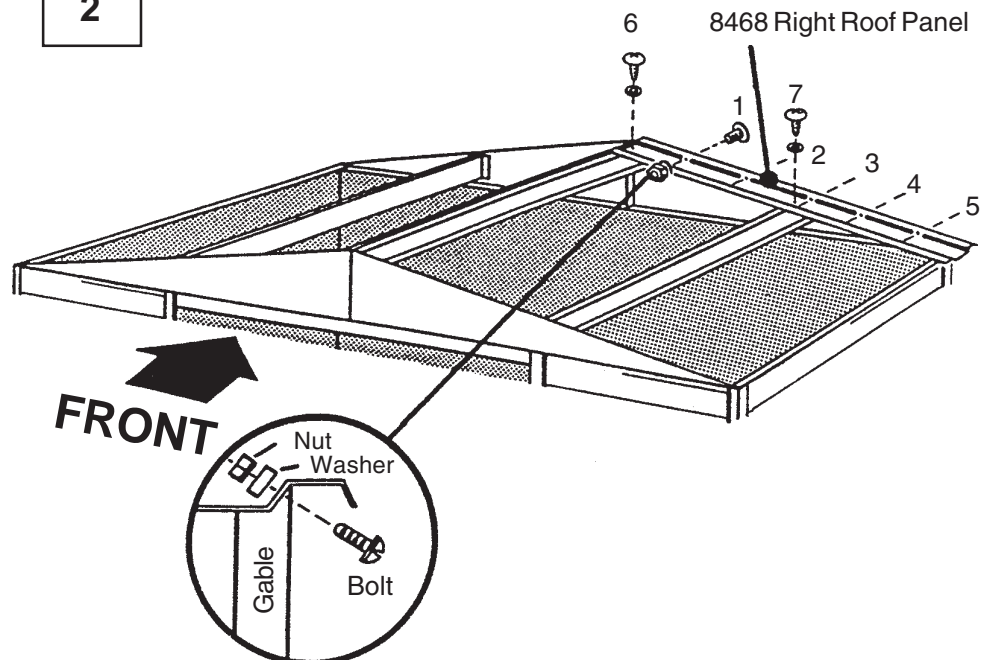

Step 15

Y28

● Parts Needed For ● Roof Assembly

- 8468 Right Roof Panel (1)
- 8469 Left Roof Panel (2)
- 7483 Roof Panel (2)
- 6529 Roof Panel (2)
- 8840 Ridge Cap (1)

1 Install a **left roof panel** at the left rear and right front corner of the roof. Install a **right roof panel** at the left front corner of the roof.

2 Cut 4 short 2" (5,1cm) strips off the roll of **weather stripping tape**, and put them aside. Cover the joint at the peak with weather stripping tape. Unroll the tape and press it down over the opening at the ridge as you install each roof panel. Do not cut the tape at this time.

3 Install 2 **narrow** and 2 **wide roof panels** in the sequence and positions shown on previous page. *Do not fasten the lower end of the panels to the side wall angles at this time.* Continue weather stripping the ridge opening.

4 Install the first **ridge cap** on the completed roof section using bolts and nuts. Fasten roof panel overlaps not used for ridge cap. Cover the head of bolt with the 2" (5,1cm) piece of weather stripping tape. Do not fasten the ends of the ridge cap at this time.

NOTE
Narrow roof panel crimped rib is overlapped by wide rib of adjacent panel where possible.

NOTE
If roof beam holes do not line up with the roof panel holes, shift the building from left to right. If this does not help, your building may not be level. Shim the corners until holes line up.

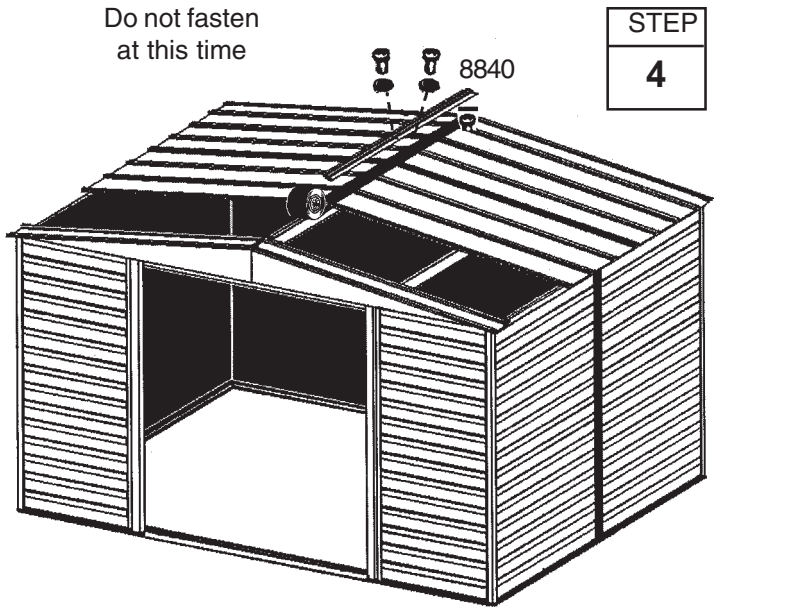
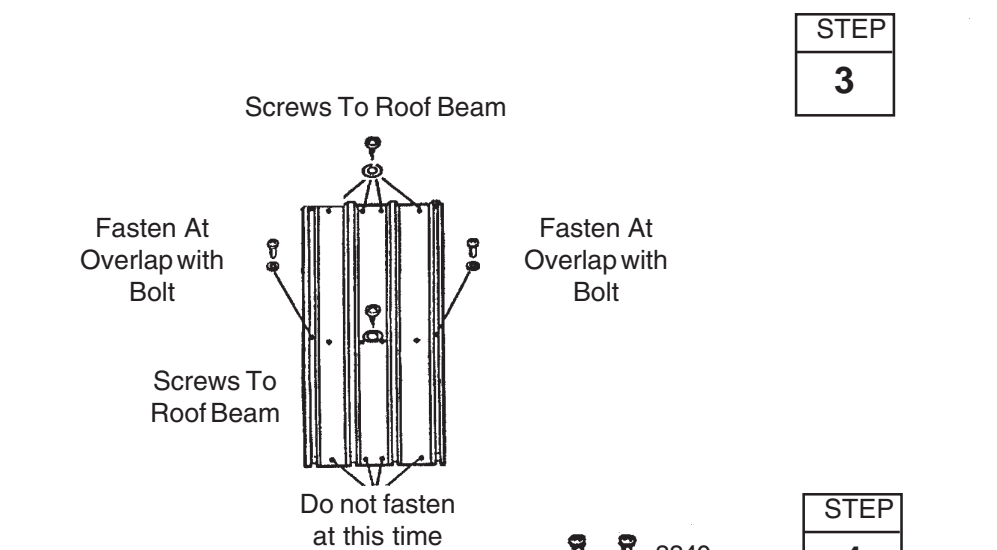
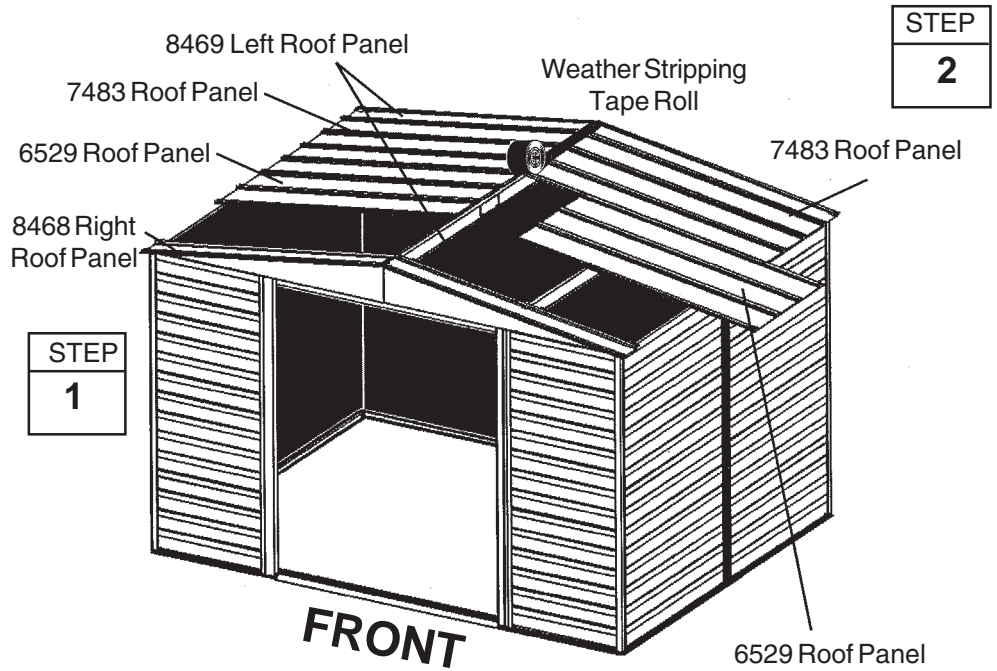

Step 16

Y29

● Parts Needed For ● Panels/Ridge Cap/Trim

- 8486 Ridge Cap (1)
- 7483 Roof Panel (2)
- 8486 Ridge Cap (1)
- 8485 Left Side Roof Trim (2)
- 8836 Right Side Roof Trim (2)

1 Install the second **ridge cap** overlapping the first ridge cap while installing the remaining **roof panels**. Continue weather stripping the ridge.

2 Fasten the lower end of the panels to the side wall angles using screws and washers. Use bolts and nuts through wall angle overlaps at the bottom of the panel.

3 Attach the **right and left side roof trim** to the lower end of the roof panels on each side of the building using screws at each panel overlap.

NOTE

A single screw fastens both trim pieces at the overlap.

4 Using your thumb and index finger, overbend the bottom flange of the side roof trim at the corner inward enough so the right and left roof trim caps fit onto right and left corners.

5 Fasten the roof trim caps to the side trim using a screw.

6 Fasten the roof panel rib, **peak cap** and ridge cap together using bolts and nuts. Fasten the remaining peak cap in the same manner.

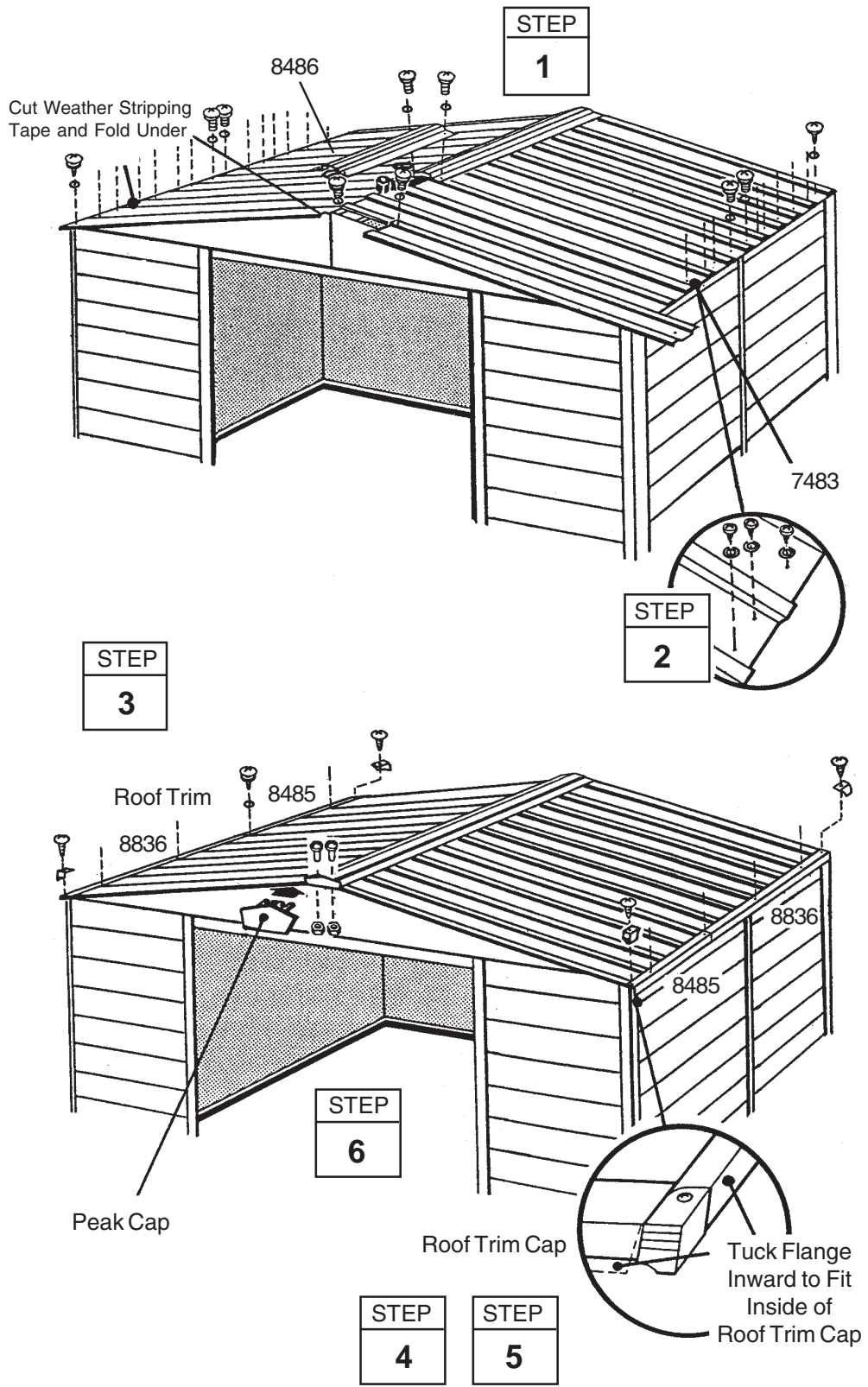

Step 17

Y30

● Parts Needed For ● Door Assembly

- 67731 Foam Board (2)
- 10493 Right and Left Doors (2)
- 10501 Horizontal Door Brace (4)
- 8641 Vertical Door Brace (2)

The steps on this page tell how to assemble the left door. You will perform exactly the same procedures for the right door. Each bolt requires a small washer on the outside of the door. Proceed as follows:

1 Place **foam board** under the lip of door.

2 Hold the **vertical door brace** against the long edge of the foam board inside the door and fasten to door using 5 bolts and nuts.

3 Put a **horizontal door brace** onto the top edge and bottom edge, covering edge of foam board, and fasten with 1 bolt in the center.

4 Attach the **lower door guides and bolts** as shown.

5 Push 7 holes through foam board where shown, using an awl or nail.

6 Fasten center of door and install **handle** using 7/8" bolts, door washers, hex nuts and acorn nuts.

7 Repeat steps 1 through 6 for the **right door**.

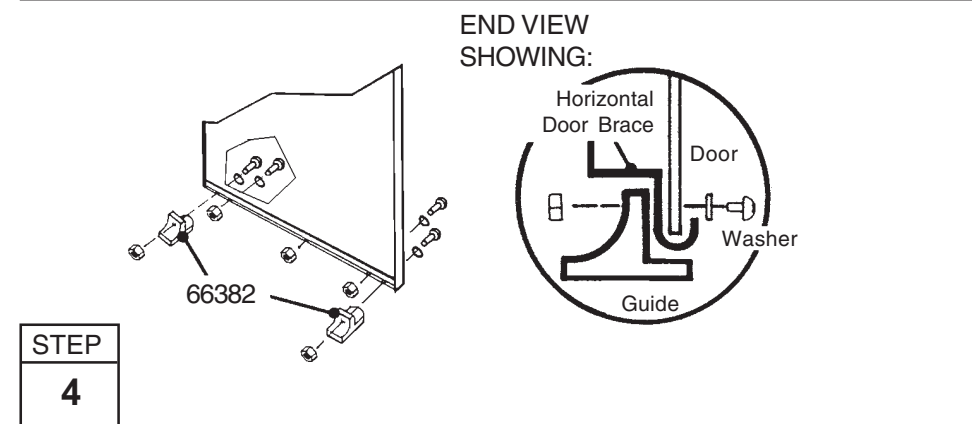
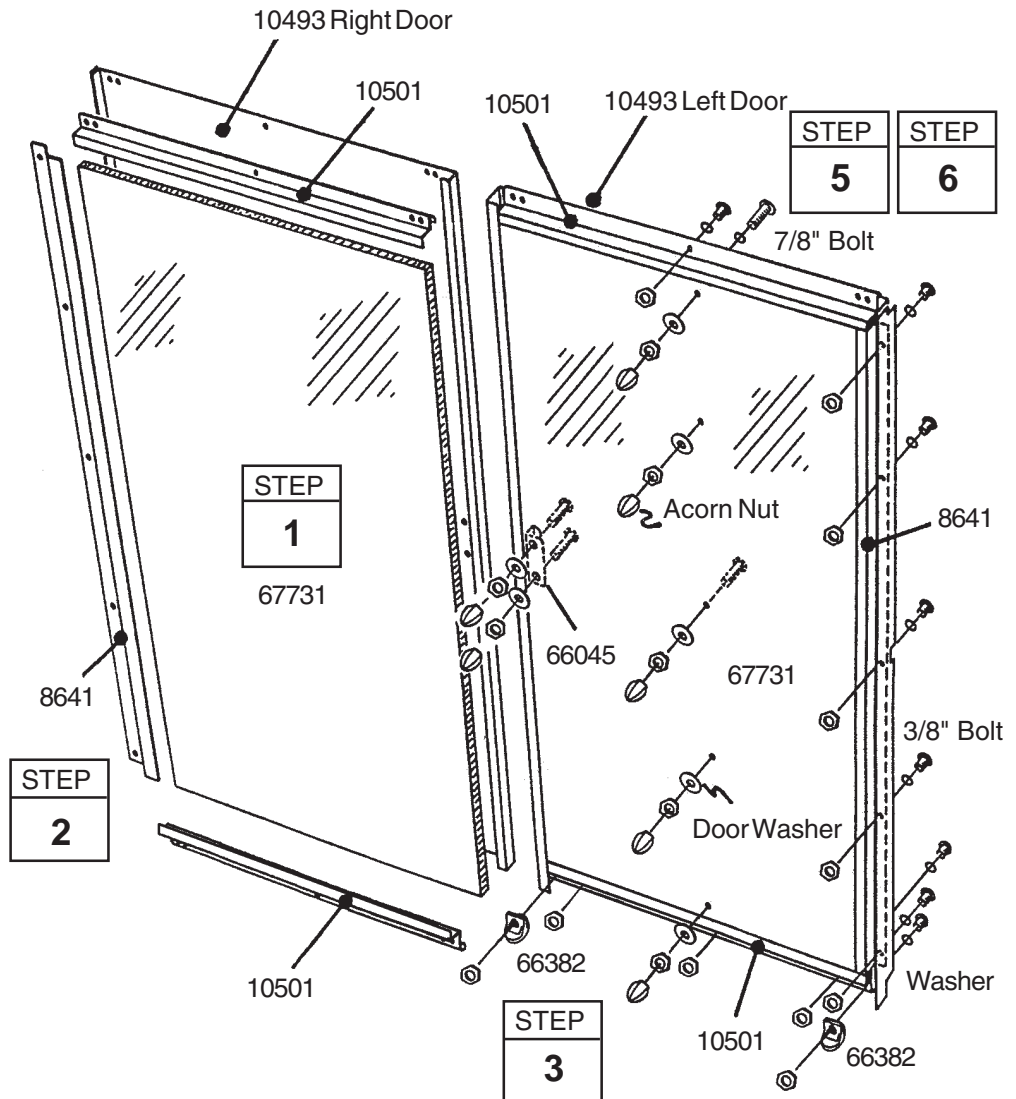

Step 18

Y31

● Parts Needed For ● Door Installation & Adjustment

- Right Door Assembly (1)
- Left Door Assembly (1)

1 From inside the building, put the bottom of the right door assembly (on your left when you are inside the building) behind door jamb into the front frame track.

2 Position the top of the door so that the holes in the door line up with the holes in the door slides.

3 Fasten the door to the door slides using two #10Bx1/2" screws per door slide.

NOTE

The holes in the door slides allow you to adjust the doors. Place the door in the middle holes.

4 Repeat steps 1 through 3 for the left door.

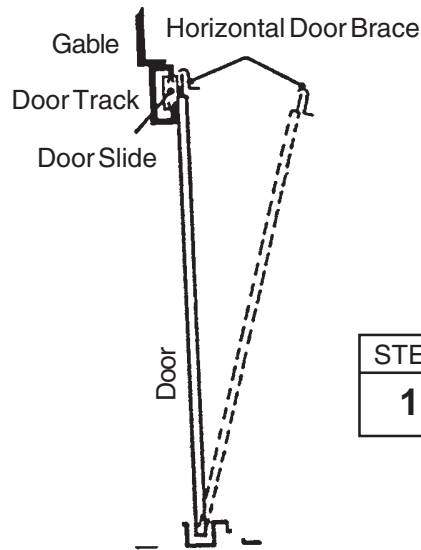

Front Floor Frame Assembly

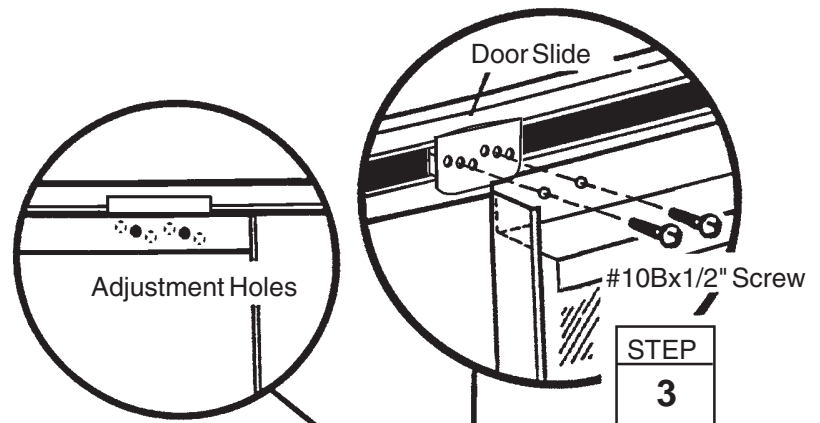

Adjustment Holes Allow Doors to Meet Evenly Along Their Length

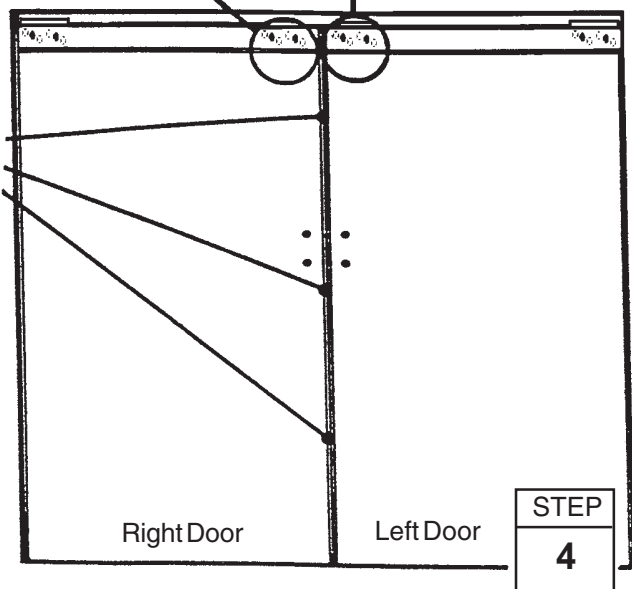

SOME FACTS ABOUT RUST

Rusting is a natural oxidizing process that occurs when bare metal is exposed to moisture. Problem areas include screw holes, unfinished edges, or where scrapes and nicks occur in the protective coating through normal assembly, handling and use. Identifying these natural rusting problem areas and taking some simple rust protection precautions can help to stop rust from developing, or stop it quickly as soon as it appears.

1. Avoid nicking or scraping the coating surface, inside and out.
2. Use all the washers supplied. In addition to protecting against weather infiltration, the washers protect the metal from being scraped by the screws.
3. Keep roof, base perimeter and door tracks free of debris and leaves which may accumulate and retain moisture. These can do double damage since they give off acid as they decay.
4. Touch up scrapes or nicks and any area of visible rust as soon as possible. Make sure the surface is free of moisture, oils, dirt or grime and then apply an even film of high quality touch-up paint.