

NOTE:
NO PROPOSED CHANGES TO
EXISTING FOOTPRINT

- NOTES:
1. THIS IS NOT A BOUNDARY SURVEY. PROPERTY LINE BEARINGS AND DIMENSIONS ARE REFERENCED FROM CITY OF PORTLAND PARCEL MAPS AND GOOGLE EARTH IMAGES.
 2. THE LOCATION OF STRUCTURES SHOWN ON THE SITE IS APPROXIMATE, AND REPRESENT THE DESIGN INTENT. ANY DIMENSIONS GIVEN ARE SUBJECT TO FIELD VERIFICATION.
 3. FIELD VERIFY AS REQUIRED.
 4. NO PROPOSED CHANGES TO FOOTPRINT.

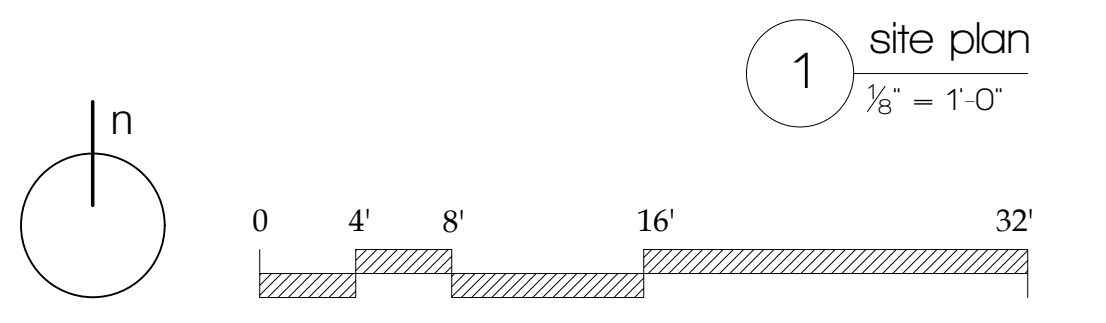

ALEXANDER LEHNEN
 51 Hammond Street
 Portland, Maine 04101
 alx.lehnen@gmail.com
 207 408 2804

renovations to
77 WILLIAM STREET
 77 William Street - Portland, Maine 04103

issue status: for construction
 date: February 2, 2017
 revision:

L1-01