

DOORS

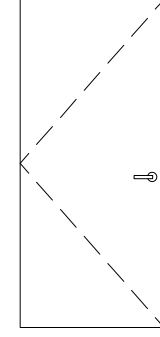

A

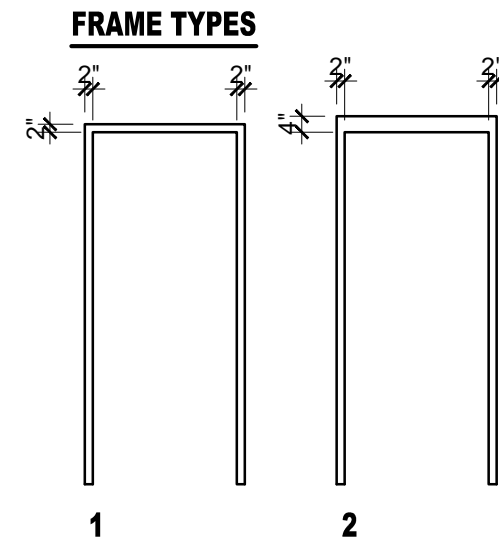

DOOR NOTES:

1. EXTERIOR DOOR JAMBS TO BE SEALED TO THEIR ROUGH OPENINGS USING LOW EXPANDING FOAM, BACKER ROD OR CAULKING.
2. ALL EXTERIOR DOORS TO BE WEATHER STRIPPED
3. ALL STOREFRONT DOORS AND FRAMES TO BE THERMALLY BROKEN WITH LOW-E ARGON FILLED INSULATED GLAZING UNITS
4. ALL GLAZING IN DOORS TO BE TEMPERED GLAZING
5. ALL HARDWARE TO BE ADA 'LEVER TYPE' HARDWARE UNLESS OTHERWISE NOTED
6. G.C. TO CONFIRM ALL DOOR SIZES WITH EXISTING OPENINGS
7. PROVIDE ALL REQUIRED BLOCKING AND FRAMING FOR OVERHEAD DOOR AND OPERATOR MOUNTING. PAINT TO MATCH WALL IT IS MOUNTED ON.

1 DOOR TYPES
1/4" = 1'-0"

DOOR SCHEDULE

DOOR NO.	DOOR						FRAME						GENERAL				
	TYPE	SIZE			FINISH	INSULATED	TYPE	MATERIAL	DETAILS			CLOSER	FREE SWING (MINUTES)	HARDWARE	HARDWARE KEY	ABBREVIATION KEY	
		WIDTH	HEIGHT	THICKNESS					MATERIAL	THRESHOLD	HEAD						JAMB
200.1	A	3'-0"	7'-0"	1-3/4"	WD	PTD	N	-	AL	AL	-	-	-	N	1 HR	-	VIF. THIS DOOR IS 1 HR FIRE RATED WITH PANIC HARDWARE - REPLACE DOOR IF NOT 1 HOUR FIRE RATED
202.1	A	3'-0"	7'-0"	1-3/4"	WD	PTD	N	-	AL	AL	-	-	-	N	1 HR	-	
202.2	A	3'-0"	7'-0"	1-3/4"	WD	PTD	N	-	AL	AL	-	-	-	N	1 HR	-	
203.1	A	3'-0"	7'-0"	1-3/4"	WD	PTD	N	-	AL	AL	-	-	-	N	1 HR	-	
204.1	A	3'-0"	7'-0"	1-3/4"	WD	PTD	N	-	AL	AL	-	-	-	N	1 HR	-	
205.1	A	3'-0"	7'-0"	1-3/4"	WD	PTD	N	-	AL	AL	-	-	-	N	1 HR	-	
206.1	A	3'-0"	7'-0"	1-3/4"	WD	PTD	N	-	AL	AL	-	-	-	N	1 HR	-	
207.1	A	3'-0"	7'-0"	1-3/4"	WD	PTD	N	-	AL	AL	-	-	-	N	1 HR	-	
208.1	A	3'-0"	7'-0"	1-3/4"	WD	PTD	N	-	AL	AL	-	-	-	N	1 HR	-	
209.1	A	3'-0"	7'-0"	1-3/4"	WD	PTD	N	-	AL	AL	-	-	-	N	1 HR	-	
211.1	A	3'-0"	7'-0"	1-3/4"	WD	PTD	N	-	AL	AL	-	-	-	N	1 HR	-	
212.1	A	3'-0"	7'-0"	1-3/4"	WD	PTD	N	-	AL	AL	-	-	-	N	1 HR	-	
213.1	A	3'-0"	7'-0"	1-3/4"	WD	PTD	N	-	AL	AL	-	-	-	N	1 HR	-	
216.1	A	3'-0"	7'-0"	1-3/4"	WD	PTD	N	-	AL	AL	-	-	-	N	1 HR	-	
217.1	A	3'-0"	7'-0"	1-3/4"	WD	PTD	N	-	AL	AL	-	-	-	N	1 HR	-	
218.1	A	3'-0"	7'-0"	1-3/4"	WD	PTD	N	-	AL	AL	-	-	-	N	1 HR	-	
219.1	A	3'-0"	7'-0"	1-3/4"	WD	PTD	N	-	AL	AL	-	-	-	N	1 HR	-	
220.1	A	3'-0"	7'-0"	1-3/4"	WD	PTD	N	-	AL	AL	-	-	-	N	1 HR	-	
221.1	A	3'-0"	7'-0"	1-3/4"	WD	PTD	N	-	AL	AL	-	-	-	N	1 HR	-	
222.1	A	3'-0"	7'-0"	1-3/4"	WD	PTD	N	-	AL	AL	-	-	-	N	1 HR	-	
224.1	A	3'-0"	7'-0"	1-3/4"	WD	PTD	N	-	AL	AL	-	-	-	N	1 HR	-	VIF. THIS DOOR IS 1 HR FIRE RATED WITH PANIC HARDWARE - REPLACE DOOR IF NOT 1 HOUR FIRE RATED
225.1	A	3'-0"	7'-0"	1-3/4"	WD	PTD	N	-	AL	AL	-	-	-	N	1 HR	-	
226.1	A	3'-0"	7'-0"	1-3/4"	WD	PTD	N	-	AL	AL	-	-	-	N	1 HR	-	
300.1	A	3'-0"	7'-0"	1-3/4"	WD	PTD	N	-	AL	AL	-	-	-	N	1 HR	-	VIF. THIS DOOR IS 1 HR FIRE RATED WITH PANIC HARDWARE - REPLACE DOOR IF NOT 1 HOUR FIRE RATED
301.1	A	3'-0"	7'-0"	1-3/4"	WD	PTD	N	-	AL	AL	-	-	-	N	1HR	-	
301.2	A	3'-0"	7'-0"	1-3/4"	WD	PTD	N	-	AL	AL	-	-	-	N	1 HR	-	
302.1	A	3'-0"	7'-0"	1-3/4"	WD	PTD	N	-	AL	AL	-	-	-	N	1HR	-	
303.1	A	3'-0"	7'-0"	1-3/4"	WD	PTD	N	-	AL	AL	-	-	-	N	1HR	-	
304.1	A	3'-0"	7'-0"	1-3/4"	WD	PTD	N	-	AL	AL	-	-	-	N	1HR	-	
307.1	A	3'-0"	7'-0"	1-3/4"	WD	PTD	N	-	AL	AL	-	-	-	N	1 HR	-	
307.2	A	3'-0"	7'-0"	1-3/4"	WD	PTD	N	-	AL	AL	-	-	-	N	1 HR	-	
309.1	A	3'-0"	7'-0"	1-3/4"	WD	PTD	N	-	AL	AL	-	-	-	N	1 HR	-	
310.1	A	3'-0"	7'-0"	1-3/4"	WD	PTD	N	-	AL	AL	-	-	-	N	1 HR	-	
311.1	A	3'-0"	7'-0"	1-3/4"	WD	PTD	N	-	AL	AL	-	-	-	N	1 HR	-	VIF. THIS DOOR IS 1 HR FIRE RATED WITH PANIC HARDWARE - REPLACE DOOR IF NOT 1 HOUR FIRE RATED
311.2	A	3'-0"	7'-0"	1-3/4"	WD	PTD	N	-	AL	AL	-	-	-	N	1 HR	-	1 HR FIRE RATED WITH PANIC HARDWARE
312.1	A	3'-0"	7'-0"	1-3/4"	WD	PTD	N	-	AL	AL	-	-	-	N	-	-	
312.2	A	3'-0"	7'-0"	1-3/4"	WD	PTD	N	-	AL	AL	-	-	-	N	1 HR	-	

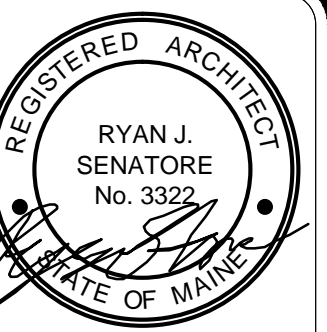

© 2015 RYAN SENATORE ARCHITECTURE

UNITED INSURANCE AGENCY
470 FOREST AVE.
PORTLAND, MAINE



RYAN SENATORE ARCHITECTURE
565 CONGRESS ST.
PORTLAND, MAINE 04101
207-650-6414
senatorearchitecture.com

CONSULTANTS:

REVISIONS:

DATE: MARCH 31, 2015

PROJECT No. 1446

DRAWN BY: RRT / RJS

CHECKED BY: RJS

SCALE: AS NOTED

SHEET TITLE:

SCHEDULES

A7-0