

Submittal Data: 15RLS3H
Inverter Driven Heat Pump

15,000 BTU Wall Mount

Job Name: LAWTON

Date: 3/13/2018

Location: _____

Approval: _____

Engineer: _____

Construction: _____

Submitted to: _____

Unit #: _____

Submitted by: _____

Drawing #: _____

Reference: _____

General Features

- Wired or wireless remote
- Energy saving program
- Sleep timer
- 24-hour timer
- Weekly timer
- Dry mode
- Powerful mode
- High performance heating
- Base pan heater
- Standard Warranty: 5 years parts, 7 years compressor. Applies to systems purchased before June 1st 2015*
- Extended Warranty: 10 years parts, 10 years compressor. Systems that have been installed on or after June 1st 2015 by licensed contractors and the online Product Registration has been submitted.**
- Elite Contractor Extended Warranty: 12 years parts, 12 years compressor. Systems that have been installed on or after June 1st 2015 by contractors who have met requirements and have been approved for elite contractor status plus, the online Product Registration has been submitted.***

Model Information

Condenser..... AOU15RLS3H
Evaporator..... ASU15RLS3

Electrical

208/230V AC 1ph-60Hz
Available Voltage Range..... 208/230 +/- 10%
Minimum Circuit Ampacity..... 18.2 A
Max Fuse Size..... 20A
Max Starting Current..... 5.2 A

Input Power

Cooling..... 1.04 kW
Heating..... 1.15 kW

Running Current

Cooling..... 4.8 A
Heating..... 5.2 A

Capacity

Nominal Cooling..... 15,000 Btu
Min-Max Cooling..... 3,100-18,400 Btu/h
Nominal Heating..... 18,000 Btu/h
Min-Max Heating..... 3,100-23,900 Btu/h

Compressor

Rotary (inv x1)
Motor Output..... 1,000 W
Refrigerant..... R410a
Charge..... 3 lbs. 1 oz
Oil..... FREOL a68SZ

Fan Motor

(Condenser) Type: DC..... Propeller x 1
(Condenser) Motor Output..... 49 W
(Evaporator) Type: DC..... Cross flow fan x1
(Evaporator) Motor Output..... 61 W

Heat Exchanger {Condenser (C) Evaporator (E)}

Dimensions (H x W x D)
Condenser..... 23-1/8 x 34-11/16 x 1-7/16 in. (588x881x36.4 mm)
Evaporator..... Main 15-1/8 x 28-3/8 x 1-3/16 in. (384x720x30) Sub 3-5/16 x 28-3/8 x 1/2 in. (84x720x13.3 mm) 4-15/16 x 28-3/8 x 1/2 in. (126x720x13.3 mm)
Fin Pitch..... 20 FPI (C) Main 21 FPI Sub 18 FPI (E)
Rows x Stages..... 2 x 28 (C) Main 3 x 24 Sub 1 x 10 (E)
Pipe Type (Material)..... Copper (C) Copper (E)
Fin Type (Material)..... Aluminum (C) Aluminum (E)

Note: Specifications are based on the following conditions:
Cooling: Indoor temperature of 80°F (26.7°C) DB/67°F (19.44°C) WB, and outdoor temperature of 95°F (35°C) DB/75°F (23.9°C) WB.
Heating: Indoor temperature of 70°F (21.1°C) DB/59°F (15°C) WB, and outdoor temperature of 47°F (8.33°C) DB/43°F (6.11°C) WB.
Pipe length: 24ft. Fin (7.5m), Height difference: 0ft. (0m) (Outdoor unit - indoor unit) (*Standard warranty**10 year warranty***12 year warranty)

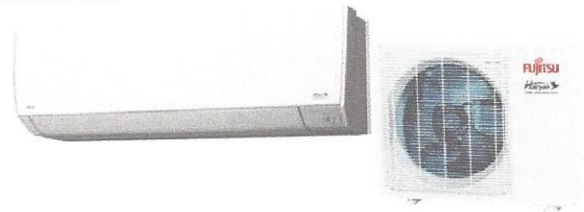

Operation Temperature Range

Cooling..... 14°F (-10°C) to 115°F (46°C)
Heating..... -15°F (-26°C) to 75°F (24°C)

Efficiency

SEER..... 25.3
EER (cooling)..... 4.09 kW/kW
COP (heating)..... 4.59 kW/kW
HSPF (heating)..... 13.3 Btu/hW

Enclosure (Condenser)

Material..... Painted galvanized steel
Color..... Beige (10 YR 7.5/1.0 NN)

Sound Pressure Level

Condenser..... 49 dB(A)
Evaporator..... 45 dB(A)

Dimensions

H x W x D
Condenser in. (mm)..... 24-1/2 (620) x 31-1/8 (790) x 11-7/16 (290)
Evaporator in. (mm)..... 11- 5/8 (295) x 37 (940) x 10-5/8 (270)

Connection Pipe

Liquid..... 1/4" / 6.35 mm Flare
Gas..... 1/2" / 12.7 mm Flare
Method (Liquid/Gas)..... Brazing
Max Length (Pre-charge)..... 66 ft. (20 m) / (49 ft. {15 m})
Max Height Difference..... 49 ft. (15 m)

Weight

Condenser..... 88 lbs. (40 kg)
Evaporator..... 31 lbs. (14 kg)

Accessories

UTY-RVNUM^..... Wired remote controller (backlit, shows room temp.)
UTY-RNNUM^..... Wired remote controller
UTY-RSNUM^..... Wired remote controller (simple)
UTY-TWBXF1..... Interface kit
UTY-XWZXZ5..... Dry contact wire kit

Intertek ETL Number

AOU15RLS3H..... 91986
ASU15RLS3..... 91986

*1 Requires interface kit # UTY-TWBXF1 in order to connect these devices to them.



Fujitsu General America, Inc.
353 Route 46 West
Fairfield, NJ 07004
Toll Free: 1-888-888-3424
Fax: (973) 836-0447
www.fujitsugeneral.com

Dimensions: 15RLS3H

[Unit: in. (mm)]

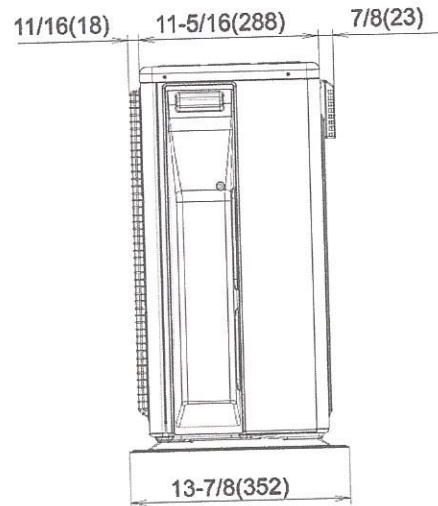
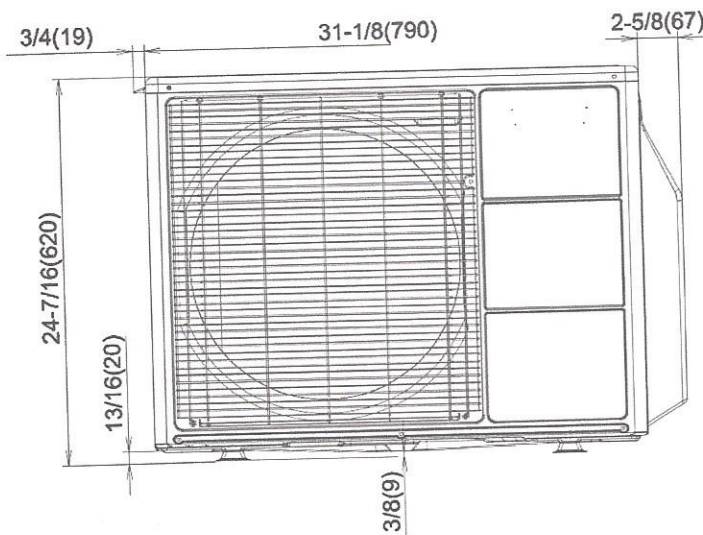
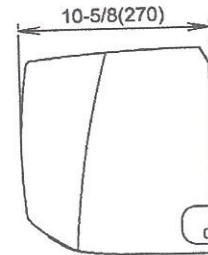
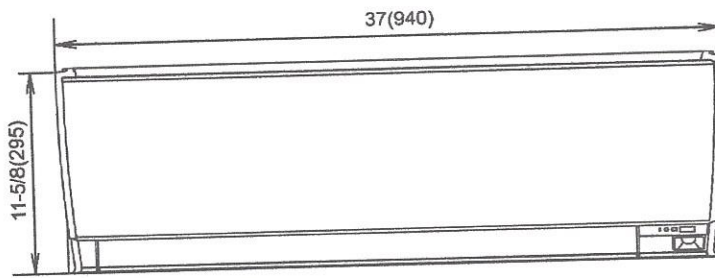

Front view

Side view

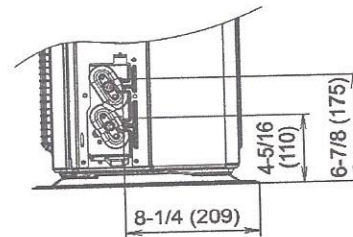
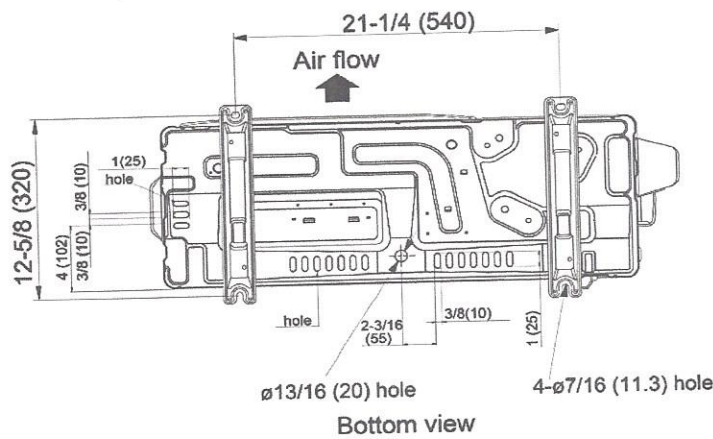

Bottom view

The Fujitsu logo is a registered trademark of Fujitsu Limited.
The Halcyon logo and name is a trademark of Fujitsu General America, Inc.
Copyright 2016 Fujitsu General America, Inc.
Fujitsu's products are subject to continuous improvements. Fujitsu reserves the right to modify product design, specifications and information in this brochure without notice and without incurring any obligations.

Submittal Data: 24RLXFZH
Inverter Driven Heat Pump

Job Name: LAWTON

Location: _____

Engineer: _____

Submitted to: _____

Submitted by: _____

Reference: _____

Date: 3/13/2018

Approval: _____

Construction: _____

Unit #: _____

Drawing #: _____

General Features

- Wired or wireless remote
- Apple catechin filter
- Ion deodorizing filter
- Auto louver: up/down
- Auto louver: 4-way
- Low ambient cooling
- Cold prevention
- Blue fin coating
- Standard Warranty: 5 years parts, 7 years compressor. Applies to systems purchased before June 1st 2015*
- Extended Warranty: 10 years parts, 10 years compressor. Systems that have been installed on or after June 1st 2015 by licensed contractors and the online Product Registration has been submitted.**
- Elite Contractor Extended Warranty: 12 years parts, 12 years compressor. Systems that have been installed on or after June 1st 2015 by contractors who have met requirements and have been approved for elite contractor status plus, the online Product Registration has been submitted.***

Model Information

Condenser..... AO24RLXFZH
Evaporator..... (ASU) / (ARU) / (AGU) / (AUU) 7,9,12RLF(1)
Connectable indoor units..... 2 - 3
Total capacity range..... 14,000 - 27,000 Btu/h

Electrical

Available Voltage Range..... 208/230V AC 1ph-60Hz
Minimum Circuit Ampacity..... 25.1 A
Max Fuse Size..... 30 A
Max Starting Current..... 8.3 A

Input Power

Cooling..... (non-duct) 1.65 kW / (ducted) 1.81 kW / (mix) 1.74 kW
Heating..... (non-duct) 1.81 kW / (ducted) 1.89 kW / (mix) 1.85 kW

Current

Cooling..... (non-duct) 7.2 A / (ducted) 7.9 A / (mix) 7.6 A
Heating..... (non-duct) 7.9 A / (ducted) 8.3 A / (mix) 8.1 A

Capacity

Nominal Cooling..... 22,000 Btu/h
Min-Max Cooling..... 6,100 - 27,000 Btu/h
Nominal Heating..... 25,000 Btu/h
Min-Max Heating..... 6,800 - 29,800 Btu/h

Compressor

Motor Output..... Rotary (inv x1) 2,100 W
Refrigerant..... R410a
Charge..... 4 lbs. 14 oz
Oil..... RB68

Fan Motor

(Condenser) Type: DC..... Propeller x1
(Condenser) Motor Output..... 100 W
(Evaporator) Type: DC..... (wall-mount) Cross flow
(compact cassette) Turbo
(ducted) Sirocco x2 (18 k x3)
(floor) Cross flow x2

(Evaporator) Motor Output..... (wall) 30W-42W (compact cassette) 54W (ducted) 80-81W
(floor) 16W

Heat Exchanger

Dimensions..... (H x W x D) in. (mm) 31-7/16 x 35-7/16 x 1-7/16 (798x900x36.38)

Fin Pitch..... 20 FPI

Rows x Stages..... 2 x 38

Pipe Type (Material)..... Copper

Fin Type (Material)..... Aluminum (Blue fin)

Operation Temperature Range

Cooling..... 14°F - 115°F (-10°C - 46°C)
Heating..... -15°F - 75°F (-26°C - 24°C)

Efficiency

SEER[^]..... (wall-mount) 20 (duct) 18 (mix) 19
EER (cooling)..... (wall-mount) 13.3 Btu/W (duct) 12.1 Btu/W (mix) 12.7 Btu/W
COP (heating)..... (wall-mount) 4.04 W/W (duct) 3.87 W/W (mix) 3.96 W/W
HSPF (heating)..... (wall-mount) 10.3 (duct) 9 (mix) 9.7

Enclosure (Condenser)

Material..... Painted galvanized steel
Color..... Beige (10 YR 7.5/1.0 NN)

Sound Pressure Level

Condenser..... 52 dB(A)

Dimensions

H x W x D
Condenser
Net in. (mm)..... 32-11/16 x 35-7/16 x 13 (830x900x330)
Gross in. (mm)..... 38-3/16 x 41-5/16 x 17-1/2 (970x1,050x445)

Connection Pipe

Liquid..... 1/4" x3
Gas..... 3/8" x2 + 1/2" x1
Method (Liquid/Gas)..... Brazing
Max Length (Pre-charge)..... 229ft. (70m) / (98 ft. {30m})
Max Height Difference..... 49 ft. (15m)

Weight

Condenser..... 146 lbs. (66 kg)
Evaporators..... (wall-mount) 19 lbs. - 31 lbs.
(compact cassette) 33 lbs.
(ducted) 37 lbs. - 49 lbs.
(floor) 31 lbs.

Accessories

Wired Remote Controller..... UTY-RVNUM
Wired Remote Controller..... UTY-RNNUM
Simple Remote Controller..... UTY-RSNUM

Intertek® ETL Number

AO24RLXFZH..... 91987

*Reference brochure for approved combinations. **Test conditions are based on AHRI 210/240.
Note: Specifications are based on the following conditions: Cooling: Indoor temperature of 80°F (26.7°C) DB/67°F (19.44°C) WB, and outdoor temperature of 95°F (35°C) DB/75°F (23.9°C) WB. Heating: Indoor temperature of 70°F (21.1°C) DB/59°F (15°C) WB, and outdoor temperature of 47°F (8.3°C) DB/43°F (6.11°C) WB. Pipe length: 24ft. 7in. (7.5m). Height difference: 0ft. (0m) (Outdoor unit - indoor unit) (*Standard warranty**10 year warranty***12 year warranty)

Fujitsu General America, Inc.
353 Route 46 West
Fairfield, NJ 07004
Toll Free: 1-888-888-3424
Fax: (973) 836-0447
www.fujitsugeneral.com



Dimensions: 24RLXFZH

[Unit: in. (mm)]

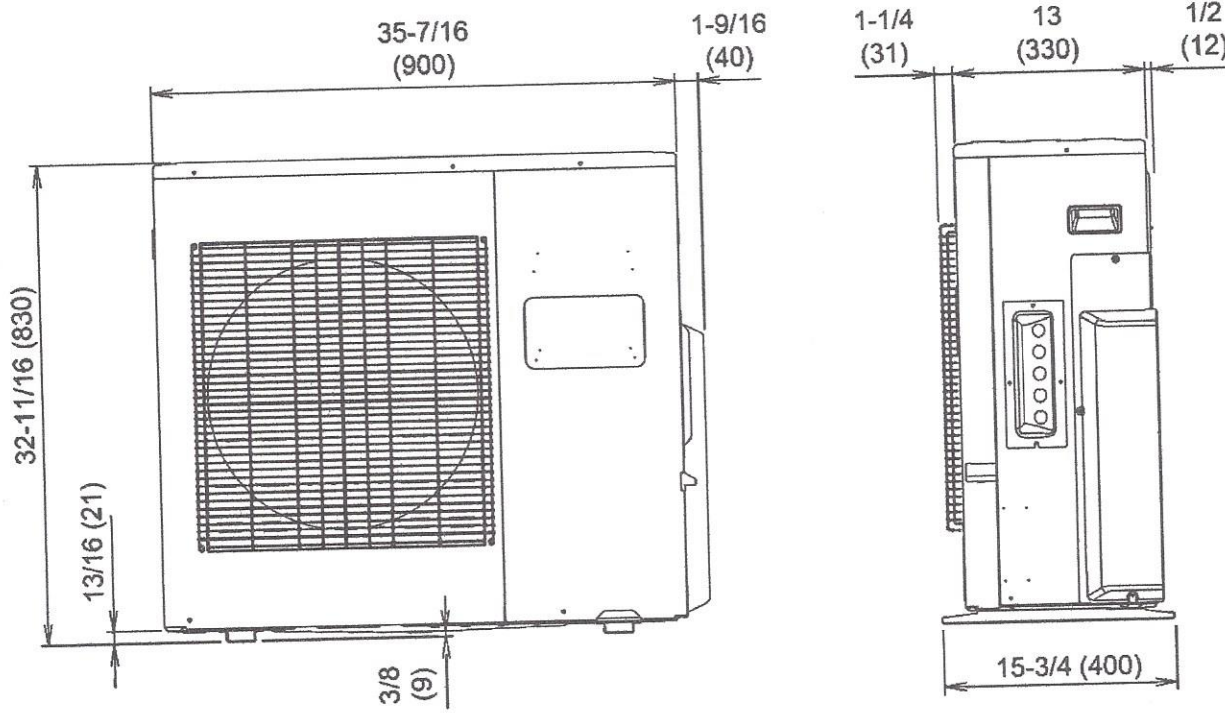

Front view

Side view

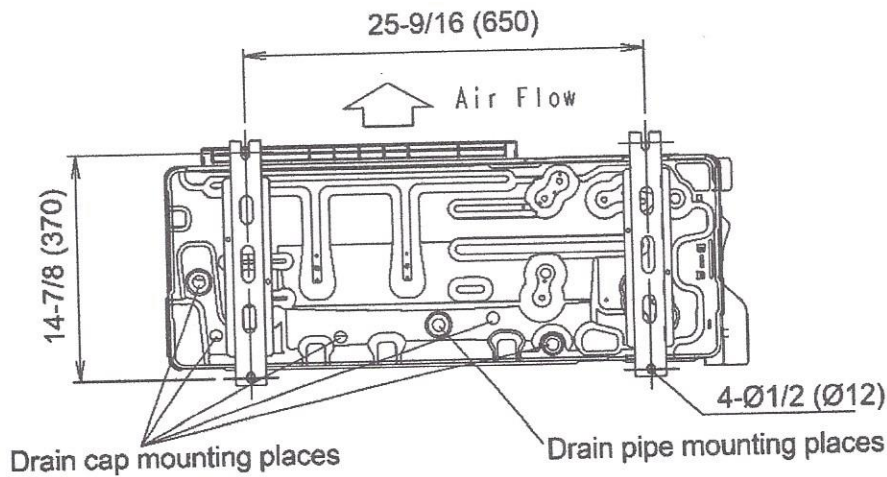

Bottom view

Submittal Data: ASU7RLF1
Inverter Driven Heat Pump

Job Name: LAWTON
 Location: _____
 Engineer: _____
 Submitted to: _____
 Submitted by: _____
 Reference: _____

Date: 3/13/2018
 Approval: _____
 Construction: _____
 Unit #: _____
 Drawing #: _____

General Features

- Refrigerant Type R410A.
- Wired and wireless remote controllers
- Auto changeover
- Weekly timer
- Removable open panel
- Super quiet operation
- Removable air filter
- Program timer
- 5 years standard parts warranty
- Eligible for 10 year or 12 year parts warranty. See warranty statement for details.



Model Information

Evaporator..... ASU7RLF1
 Condenser compatibility..... AOU18RLXFZ, AOU18RLXFZH
 AOU24RLXFZ, AOU24RLXFZH
 AOU36RLXFZ, AOU36RLXFZ1, AOU36RLXFZH
 AOU45RLXFZ, AOU48RLXFZ1

Electrical

Available Voltage Range..... 208/230V AC 1ph-60Hz
 Minimum Circuit Ampacity..... 208/230 +/- 10%
 Full Load Amps..... 0.18 A
 Input Power..... 0.14 A
 Running Current..... 15 W
 0.13 A

Capacity

Nominal Cooling..... 7,000 Btu/h

Fan Motor

Type: DC Cross flow x1
 Motor Output..... 30 W
 Fan Motor Protection..... off: 221 ± 18°F (105 ± 10°C)
 on: 194 ± 18°F (90 ± 10°C)

Airflow Rate

Cooling (High / Medium / Low / Quiet)
 330 CFM (560 m3/h) / 294 CFM (500 m3/h) / 253 CFM (430 m3/h) / 182 CFM (310 m3/h)
 Heating (High / Medium / Low / Quiet)
 330 CFM (560 m3/h) / 294 CFM (500 m3/h) / 253 CFM (430 m3/h) / 194 CFM (330 m3/h)

Heat Exchanger

Dimensions (H x W x D) in. (mm)..... 12-5/8 x 24-13/16 x 13/16 (320x630x20)
 Fin Pitch..... Main 23 FPI / Sub 18 FPI
 Rows x Stages..... Main 2 x20 / Sub 1 x4
 Pipe Type (Material)..... Copper
 Type (Material)..... Aluminum

Temperature Setting Range

Cooling..... 64°F - 90°F (18°C - 32°C)
 Heating..... 60°F - 88°F (16°C - 30°C)

Enclosure

Material..... Galvanized Steel Sheet

Sound Pressure Level

Cooling High/Medium/Low/Quiet..... 36 dB (A) / 32 dB (A) / 29 dB (A) / 21 dB (A)
 Heating High/Medium/Low/Quiet..... 36 dB (A) / 32 dB (A) / 29 dB (A) / 22 dB (A)

Dimensions

H x W x D in. (mm)..... 10-9/16 x 33-1/16 x 8 (268x840x203)

Connection Pipe

Liquid..... 1/4" in. (6.35 mm)
 Gas..... 3/8" in. (9.52 mm)
 Method (Liquid/Gas)..... Flare
 Drain hose Material..... PP + LLDPE
 Size..... Ø9/16 (I.D.), Ø5/8 to Ø11/16 [Ø13.8 (I.D.), Ø15.8 to Ø16.7 O.D.]

Weight

Net..... 19 lbs. (8.5 kg)
 Gross..... 23 lbs. (10.5 kg)

Accessories

Wired Remote Controller..... UTY-RNNUM
 Backlit Display..... UTY-RVNUM
 Simple Remote Controller..... UTY-RSNUM
 Dry Contact Wire Kit..... UTY-XWZXZ5
 Interface Kit..... UTY-XCBXZ2

Intertek® ETL Number

ASU7RLF1..... 91986

Note: Specifications are based on the following conditions.
 Cooling: Indoor temperature of 80°F (26.7°C) DB/67°F (19.44°C) WB, and outdoor temperature of 95°F (35°C) DB/75°F (23.9°C) WB.
 Heating: Indoor temperature of 70°F (21.1°C) DB/59°F (15°C) WB, and outdoor temperature of 47°F (8.33°C) DB/43°F (6.11°C) WB.
 Pipe length: 24ft. 7in. (7.5m), Height difference: 0ft. (0m) (Outdoor unit - indoor unit)



Fujitsu General America, Inc.
 353 Route 46 West
 Fairfield, NJ 07004
 Toll Free: 1-888-888-3424
 Fax: (973) 836-0447
www.fujitsugeneral.com

Dimensions: ASU7RLF1

[Unit: in. (mm)]

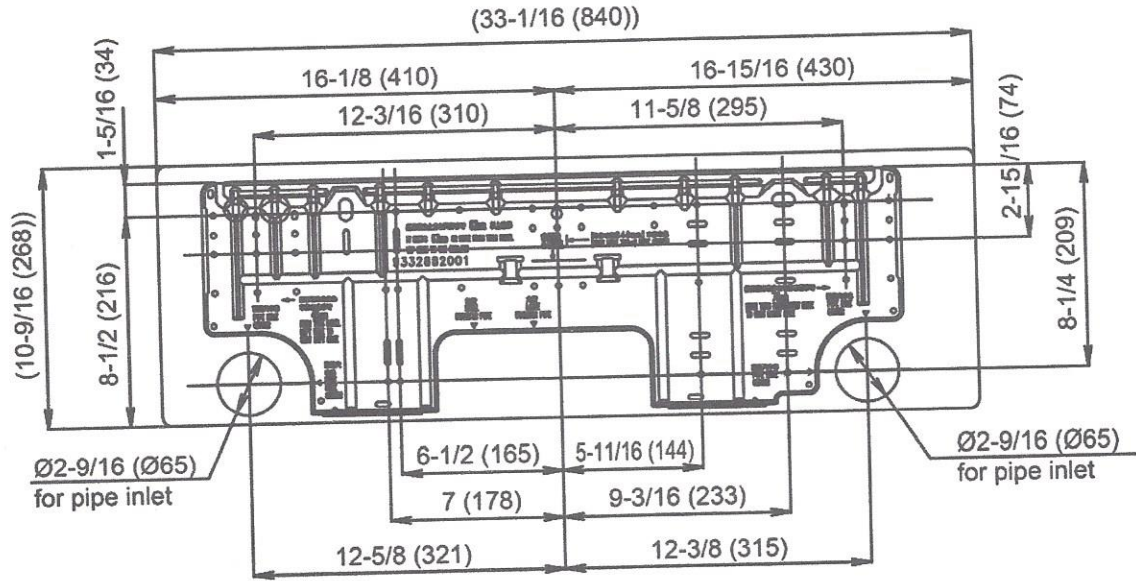
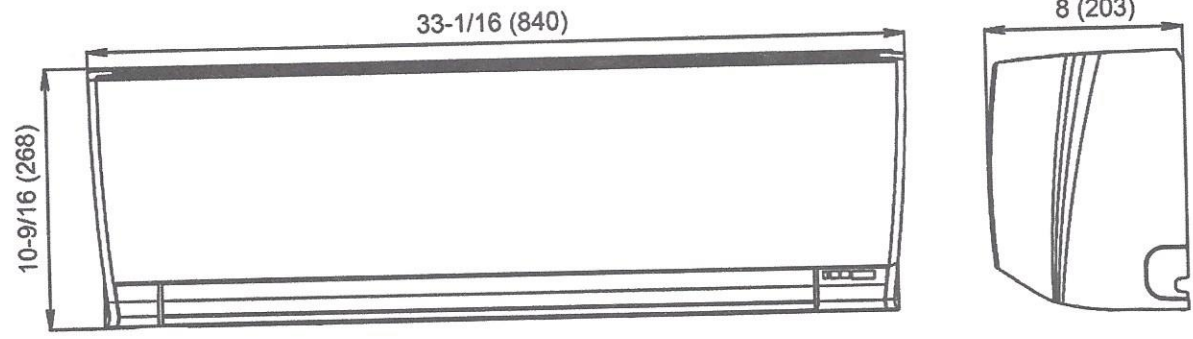

The Fujitsu logo is a registered trademark of Fujitsu Limited.
 The Halcyon logo and name is a trademark of Fujitsu General America, Inc. Copyright 2016 Fujitsu General America, Inc.
 Fujitsu's products are subject to continuous improvements. Fujitsu reserves the right to modify product design, specifications and information in this brochure without notice and without incurring any obligations.