



PO Box 2551
2257 West Broadway
South Portland, ME 04106

1.800.370.3473
fax 207.879.0540

www.norrisinc.com

Please fax this information to the Administrative Sales Assistant at the So. Portland Office at (207)-879-0540.

Building Owner Information Form

Job Name:	Project #:
-----------	------------

Electrical Contractor:

NFPA requires this information for proper documentation

****The contractor MUST provide all of the information with an asterisk below before ANY equipment can be released.***

If building owner contact is unknown provide contact name/tel. of GC and check box

Electrical Contractor Contact Name:	
Estimated Date Equip. Needed:	*Estimated Finals Date:

*Building Owner:

*Job Site Address:

*City:	State:	Zip:
--------	--------	------

*Contact Name:	Check here if GC
----------------	------------------

*Phone #:	Fax #:
-----------	--------



PO Box 2551
2257 West Broadway
South Portland, ME 04106

1.800.370.3473
fax 207.879.0540

www.norrisinc.com

Thank you for your cooperation.

Please advise the building owners that if this system is equipped with a digital communicator, then they MUST also make monitoring arrangements prior to a certificate of occupancy. Norris Inc. will attempt to contact the building owners

STOP!

**THIS COPY IS FOR YOUR ELECTRICIAN
ON THE JOB-SITE**

PLEASE BE SURE THIS COPY IS FORWARDED

- 1) **A riser diagram is enclosed. DO NOT USE THE ENGINEER'S RISER SHOWN ON THE PLANS. If there is any information that you question, call us immediately.**
 - 2) **YOU MUST CALL AT LEAST FIVE DAYS IN ADVANCE TO SCHEDULE FINAL CONNECTION ASSISTANCE.**
 - 3) **All of your wires must be labeled and clear of any grounds, shorts or opens and must maintain polarity throughout. Meter out all circuits before calling for final connection assistance. If applicable verify End of Line resistors are in place.**
 - 4) **If using shielded cable, the drain wires must be connected and fully insulated (wrapped with tape) so that neither the shield or the drain wire touches the backbox.**
 - 5) **Unless special arrangements are made, we will make one final job-site visit. If a special visit is required for an elevator inspection or partial occupancy, then additional charges may apply if special arrangements were not made ahead. Call your customer service representative.**
 - 6) **If you have any defective or left-over parts DO NOT WRITE ON THEM OR THE BOXES. Save the original box, all mounting hardware and instructions. Returns that do not conform to this practice will not be accepted for credit.**
 - 7) **If the system is being monitored through a digital communicator, then please turn to page 2.**
-



PO Box 2551
2257 West Broadway
South Portland, ME 04106

1.800.370.3473
fax 207.879.0540

www.norrisinc.com

IMPORTANT INFORMATION FOR THE BUILDING OWNERS SPECIAL NOTE REGARDING ALARM MONITORING SERVICES

Included within your alarm system package is a digital communicator, which sends a coded message to a private 24-hour central station if your alarm system is activated. This is a code requirement for most fire alarm systems. As a service to our customer, we offer central station monitoring services from our local UL Listed central station at extremely competitive rates.

If the central station monitoring contract is purchased through Norris Inc. prior to our scheduled start-up; we will connect, program, and test the communicator at no additional charge.

Should the building owners decide to obtain monitoring services from another company, then the cost for programming and testing the communicator will be the sole responsibility of the firm they have contracted with. Furthermore, if programming changes are made to the system by persons other than Norris Inc. technicians, then the company performing the changes shall be solely liable for any personal injury or loss of life or damage to or loss of property arising out of the use of or inability to use the system and it shall result in a waiver of any system warranties.

We appreciate that you understand the delicate nature of this life safety and/or security system and realize that serious problems may arise when modifications to the system are made including very simple programming changes.

**Call Norris Inc. at 1-800-370-FIRE (3473) to make
arrangements for central station monitoring services.**



PO Box 2551
2257 West Broadway
South Portland, ME 04106

1.800.370.3473
fax 207.879.0540

www.norrisinc.com

SUBMITTAL PACKAGE

Project: USM 25 Bedford Street

System: Fire Alarm System

**Submitted
By:** Norris Inc.
2257 West Broadway
South Portland, Maine 04106
Telephone: (800) 370-3473

**Electrical
Contractor:** Leach Electric
PO Box 907
Gray, ME. 04039

Date: May 24, 2012

Company Profile

"We are extremely proud to represent the highest quality manufacturers integrating life safety, alarm and communication systems throughout northern New England."

-- Bradford Norris, President --

Mission Statement

Provide quality engineered systems, exceptional service.

Goal

Learn...Continually Improve...Exceed Expectations

Founded in 1979 Norris Inc. has grown to become Northern New England's leading integrated system contracting and supply company. Norris Inc. is an innovated proactive organization with extensive experience in integration interdisciplinary building management systems. Our local and national affiliations assure that your project will be done properly regardless of size representing leading manufacturers our comprehensive products provide outstanding quality reliability and performance... surpassing customer application requirements and exceeding the stringent requirements of Underwriters Laboratories, National Fire Protection Association and other codes. We maintain an exceptional level of quality and provide the highest levels of customer service. Our knowledgeable technical support will insure the great service you deserve. Whether your needs involve industrial, commercial, institutional, or educational applications, you can trust that Norris Inc. has the complete resources it takes to provide the right solution right away.



PO Box 2551
2257 West Broadway
South Portland, ME 04106

1.800.370.3473
fax 207.879.0540

www.norrisinc.com

LIMITED WARRANTY

Norris, Inc. warrants that the products of its manufacturers shall be free from defects in materials or workmanship as warranted by the manufacturer which is typically for a one (1) year period from the completed installation date, but not always. The completed installation date will be the date when the end-user was able to begin using or started using the product(s) or the system, whether partially or in its entirety. For projects that have a specification or bid instructions to follow which contains specific warranty requirements, Norris Inc. will always honor the warranty terms exactly as specified in the project's specifications or bid documents, which may be more or less in coverage and duration than the manufacturer's warranty. In performing hundreds of projects per year with thousands of different products it is impossible for Norris, Inc. to track the terms and details of specified or individual product warranties. Therefore Norris, Inc. will request that the owner's representative provide these special warranty details when the warranty work is requested; otherwise a standard one year warranty on the equipment will be honored. The manufacturer's warranty is for equipment only and does not include any labor and/or shipping costs. All warranties provided by Norris, Inc. are limited with the same limitations included with the manufacturer's warranty which is included in the manuals of the products being provided.

The warranty will apply only if such goods have been properly installed, are subject to normal proper use and have not been modified in any manner whatsoever. Upon return of the defective product, Norris, Inc. will, at its sole discretion, either repair or replace, at no cost, such goods determined to have a defect in materials or workmanship. In cases of a warranty repair, Norris, Inc. will use its sole discretion to determine if a suitable replacement part can be provided on loan while the repairs are being performed.

All warranty work is performed during regular business hours. If emergency warranty work is required, the customer will pay the difference between the emergency service bill and our normal hourly charges.

Norris, Inc.'s limited warranty does not apply to those products that are damaged due to misuse, abuse, negligence, exposure to adverse environmental conditions, acts of God or have been modified in any manner whatsoever.

Norris, Inc.'s Standard terms and conditions are provided with our invoices. Those Terms and Conditions shall be provided upon request.

NORRIS, INC. SHALL NOT UNDER ANY CIRCUMSTANCES BE LIABLE FOR ANY INCIDENTAL OR CONSEQUENTIAL DAMAGES ARISING FROM LOSS OF LIFE &/OR PROPERTY OR OTHER DAMAGE OR LOSSES OWING TO THE FAILURE OF NORRIS INC. PRODUCTS BEYOND THE COST OF REPAIR OR REPLACEMENT OF ANY DEFECTIVE PRODUCTS.

NORRIS, INC. MAKES NO WARRANTY OF FITNESS OR MERCHANTABILITY AND NO OTHER WARRANTY, ORAL OR WRITTEN, EXPRESS OR IMPLIED AS ALLOWED TO THE FULLEST EXTENT OF THE LAW.

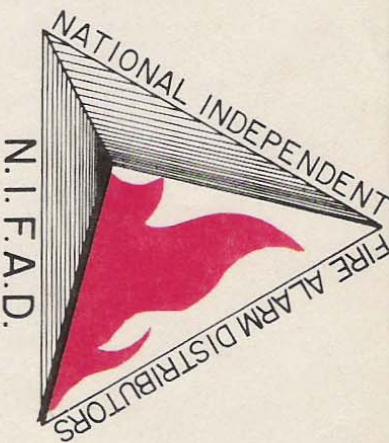

National Independent Fire Alarm Distributors Association

This is to Certify that

Morris Inc.

is a

Member in Good Standing

and is entitled to all rights and privileges of such membership

David Pomeroy

Secretary

Edgar Smith

President

NATIONAL SYSTEMS CONTRACTORS ASSOCIATION

NSCA Membership Certificate

This is to certify that

Norris Inc

is an official member of the

National Systems Contractors Association

Your membership is valid through:

January 2013

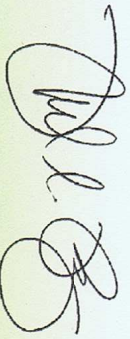

Ron Pusey
President

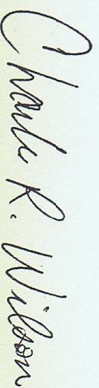

Chuck Wilson
Executive Director



This is to certify that

NORRIS, INC.

is an authorized Engineered Systems Distributor for NOTIFIER

During the year of 2011

Signed for and on behalf of NOTIFIER



Vice President Domestic Sales

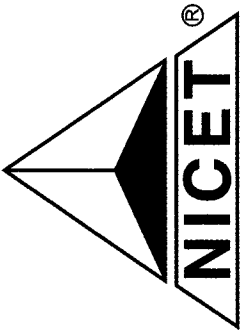

NATIONAL INSTITUTE FOR CERTIFICATION IN ENGINEERING TECHNOLOGIES®

Providing Certification Programs Since 1961

BE IT KNOWN THAT

David S. Gagnon

IS HEREBY AWARDED CERTIFICATION AT

LEVEL IV

**IN FIRE PROTECTION ENGINEERING TECHNOLOGY
FIRE ALARM SYSTEMS**

BASED UPON SUCCESSFUL DEMONSTRATION OF REQUISITE KNOWLEDGE,
EXPERIENCE AND WORK PERFORMANCE AS SET FORTH BY THIS INSTITUTE.

Certification Valid through April 1, 2014

CERTIFICATION NUMBER 88203

CHAIRMAN OF THE NICET BOARD OF GOVERNORS

A DIVISION OF THE NATIONAL SOCIETY OF PROFESSIONAL ENGINEERS

Norris Inc
2257 West Broadway
South Portland, ME 04106
1-800-370-3473

311953SP
Equipment List :
Page: 1

USM--25 Bedford St.

Description

NOTIFIER-NFS2640, Notifier NFS 640 Version 2.0
NOTIFIER-CPU2-640, NFS2-640 CPU - 120 VAC
NOTIFIER-KDM-R2, Keyboard Display Module; For CPU2-640
NOTIFIER-DP-DISP2, Dress Plate used with CPU2-640
NOTIFIER-DP-1B, Dress panel blank; painted black.
NOTIFIER-BMP-1, Blank module dress plate
NOTIFIER-DR-C4, Door, lock & keys. Accepts 3 chassis, black.
NOTIFIER-SBB-C4, Backbox, 3 chassis, black.
ADI-IM-12260F2, 12V 26 AH BATTERY FAST ON TAB
NOTIFIER-UDACT, Universal Digital Alarm Communicator Transmitter.
ADI-MO-804R2, MOD TO MOD 8C 2'RADIONICS CORD
ADI-MO-RJ31X, SFS MT 8C RJ31X UL (917UL)
NOTIFIER-NFN-GW-EM-3, Intelligent gateway interface for ONYXWorks
NOTIFIER-FSP-851, Intelligent Addressable Photo detector.
NOTIFIER-B710LP, Intelligent detector base, with flange.
NOTIFIER-FMM-101, Addressable Mini Module with FlashScan (sprinkler)
NOTIFIER-STR, Strobe, Red, Wall, 2 wire, 12/24V, multi-candela
Flashing Beacon, 120V, Red
SPAAGEELE-SSU00685, Fire Alarm Records Storage Cabinet
SPAAGEELE-IE0091, Notifier Lock
City of Portland Inspection Sticker
SPECIAL-KNOXR, Knox Box-- 4100 Series (per city requirements)
SPECIAL-KNOXR-RECESSED, Recessed Knox Box
SPECIAL-KNOXR-LIFTCOVER, Lift Cover for Knox Box
SPECIAL-KNOXR-BLACK, Black Knox Box Color
AES-7788F, UL FIRE 8 ZONE RED CASE W/2.5 DB ANTENNA
ADI-IM-1270, 12V 7AH Battery
ADI-EK-TRG1640, Transformer
NOTIFIER-FRM-1, Intelligent Addressable Relay Module.
NOTIFIER-FMM-101, Addressable Mini Module with FlashScan
ADI-GI-TSW01, Tamper Box w/ Shunt

Norris Inc
2257 West Broadway
South Portland, ME 04106
1-800-370-3473

311953SP
Equipment List :
Page: 2

USM--25 Bedford St.

Description

Disconnect Switch
City of Portland Fire Alarm Permits

NOTIFIER-NBG-12LX, Addressable Pull Station; with FlashScan.

NOTIFIER-FSP-851, Intelligent Addressable Photo detector.

NOTIFIER-B710LP, Intelligent detector base, with flange.

NOTIFIER-HSR, Horn Strobe, Red, Wall, 2 wire, 12/24V, multi-candela

NOTIFIER-STR, Strobe, Red, Wall, 2 wire, 12/24V, multi-candela

➤ NFS2-640

Intelligent Addressable Fire Alarm System



Intelligent Fire Alarm Control Panels

General

The NFS2-640 intelligent Fire Alarm Control Panel is part of the ONYX® Series of Fire Alarm Controls from NOTIFIER.

In stand-alone or network configurations, ONYX Series products meet virtually every application requirement.

Designed with modularity and for ease of system planning, the NFS2-640 can be configured with just a few devices for small building applications, or for a large campus or high-rise application. Simply add additional peripheral equipment to suit the application.

A host of other options are available, including single- or multi-channel voice; firefighters telephone; LED, LCD, or PC-based graphic annunciators; fire or integration networking; advanced detection products for challenging environments, and many additional options.

NOTE: Unless called out with a version-specific "E" at the end of the part number, "NFS2-640" refers to models NFS2-640 and NFS2-640E; similarly, "CPU2-640" refers to models CPU2-640 and CPU2-640E.

Features

- Certified for seismic applications when used with the appropriate seismic mounting kit.
- One, expandable to two, isolated intelligent Signaling Line Circuit (SLC) Style 4, 6 or 7.
- Up to 159 detectors (any mix of ion, photo, thermal, or multi-sensor) and 159 modules (Addressable pull stations, normally open contact devices, two-wire smoke, notification, or relay) per SLC. 318 devices per loop/636 per FACP or network node.
- Standard 80-character display, 640-character large display (NCA-2, or display-less (a node on a network).
- Network options:
 - High-speed network for up to 200 nodes (NFS2-3030, NFS2-640, NFS-320(C), NFS-320SYS, NCA-2, DVC, ONYXWorks, NFS-3030, NFS-640, and NCA).
 - Standard network for up to 103 nodes (NFS2-3030, NFS2-640, NFS-320(C), NFS-320SYS, NCA-2, DVC, ONYXWorks, NCS, NFS-3030, NFS-640, NCA, AFP-200, AFP-300/400, AFP-1010, and AM2020). Up to 54 nodes when DVC is used in network paging.
- 6.0 A switch mode power supply with four Class A/B built-in Notification Appliance Circuits (NAC). Selectable System Sensor, Wheelock, or Gentex strobe synchronization.
- Built-in Alarm, Trouble, Security, and Supervisory relays.
- VeriFire® Tools online or offline programming utility. Upload/Download, save, store, check, compare, and simulate panel databases. Upgrade panel firmware.
- Autoprogramming and Walk Test reports.
- Multiple central station communication options:
 - Standard UDACT
 - Internet
 - Internet/GSM
- 80-character remote annunciators (up to 32).
- EIA-485 annunciators, including custom graphics.
- Printer interface (80-column and 40-column printers).

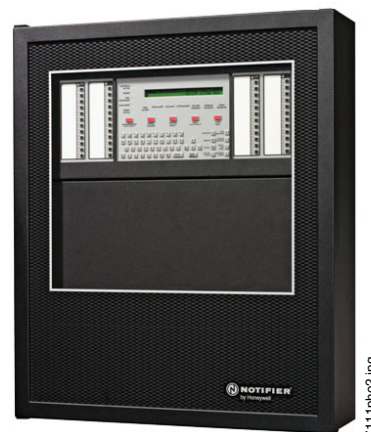

NFS2-640

7111pnc02.jpg

- History file with 800-event capacity in nonvolatile memory, plus separate 200-event alarm-only file.
- Alarm Verification selection per point, with tally.
- Presignal/Positive Alarm Sequence (PAS).
- Silence inhibit and Auto Silence timer options.
- March time/temporal/California two-stage coding/strobe synchronization.
- Field-programmable on panel or on PC, with VeriFire Tools program check, compare, simulate.
- Full QWERTY keypad.
- Battery charger supports 18 – 200 AH batteries.
- Non-alarm points for lower priority functions.
- Remote ACK/Signal Silence/System Reset/Drill via monitor modules.
- Automatic time control functions, with holiday exceptions.
- Surface Mount Technology (SMT) electronics.
- Extensive, built-in transient protection.
- Powerful Boolean logic equations.
- Support for SCS Series smoke control system in HVAC mode.

NCA-2 AS PRIMARY DISPLAY

- Backlit, 640-character display.
- Supports SCS Series smoke control system in FSCS mode when SCS is connected to the **NCA-2** used as primary display.
- Supports DVC digital audio loop.
- Printer and CRT EIA-232 ports.
- EIA-485 annunciator and terminal mode ports.
- Alarm, Trouble, Supervisory, and Security relays.

FLASHSCAN® INTELLIGENT FEATURES

- Poll up to 318 devices in less than two seconds.
- Activate up to 159 outputs in less than five seconds.
- Multicolor LEDs blink device address during Walk Test.
- Fully digital, high-precision protocol (U.S. Patent 5,539,389).

- Manual sensitivity adjustment — nine levels.
- Pre-alarm ONYX intelligent sensing — nine levels.
- Day/Night automatic sensitivity adjustment.
- Sensitivity windows:
 - **Ion** – 0.5 to 2.5%/foot obscuration.
 - **Photo** – 0.5 to 2.35%/foot obscuration.
 - **Laser (VIEW®)** – 0.02 to 2.0%/foot obscuration.
 - **Acclimate Plus™** – 0.5 to 4.0%/foot obscuration.
 - **IntelliQuad™** – 1.0 to 4.0%/foot obscuration.
 - **IntelliQuad™ PLUS** – 1.0 to 4.0%/foot obscuration
- Drift compensation (U.S. Patent 5,764,142).
- Degraded mode — in the unlikely event that the CPU2-640 microprocessor fails, FlashScan detectors revert to degraded operation and can activate the CPU2-640 NAC circuits and alarm relay. Each of the four built-in panel circuits includes a Disable/Enable switch for this feature.
- Multi-detector algorithm involves nearby detectors in alarm decision (U.S. Patent 5,627,515).
- Automatic detector sensitivity testing (NFPA-72 compliant).
- Maintenance alert (two levels).
- Self-optimizing pre-alarm.

FSL-751 (VERY INTELLIGENT EARLY WARNING) SMOKE DETECTION TECHNOLOGY

- Revolutionary spot laser design.
- Advanced ONYX intelligent sensing algorithms differentiate between smoke and non-smoke signals (U.S. Patent 5,831,524).
- Addressable operation pinpoints the fire location.
- No moving parts to fail or filters to change.

- Early warning performance comparable to the best aspiration systems at a fraction of the lifetime cost.

FAPT-851 ACCLIMATE PLUS LOW-PROFILE INTELLIGENT MULTI-SENSOR

- Detector automatically adjusts sensitivity levels without operator intervention or programming. Sensitivity increases with heat.
- Microprocessor-based technology; combination photo and thermal technology.
- FlashScan or CLIP (“classic”) mode compatible.
- Low-temperature warning signal at 40°F ± 5°F (4.44°C ± 2.77°C).

FSC-851 INTELLIQUAD ADVANCED MULTI-CRITERIA DETECTOR

- Detects all four major elements of a fire (smoke, heat, CO, and flame).
- Automatic drift compensation of smoke sensor and CO cell.
- High nuisance-alarm immunity.
- Six sensitivity levels.

FCO-851 INTELLIQUAD™ PLUS ADVANCED MULTI-CRITERIA FIRE/CO DETECTOR

- Detects all four major elements of a fire.
- Separate signal for life-safety CO detection.
- Optional addressable sounder base for Temp-3 (fire) or Temp-4(CO) tone.
- Automatic drift compensation of smoke sensor and CO cell.
- High nuisance-alarm immunity.
- Six sensitivity levels.

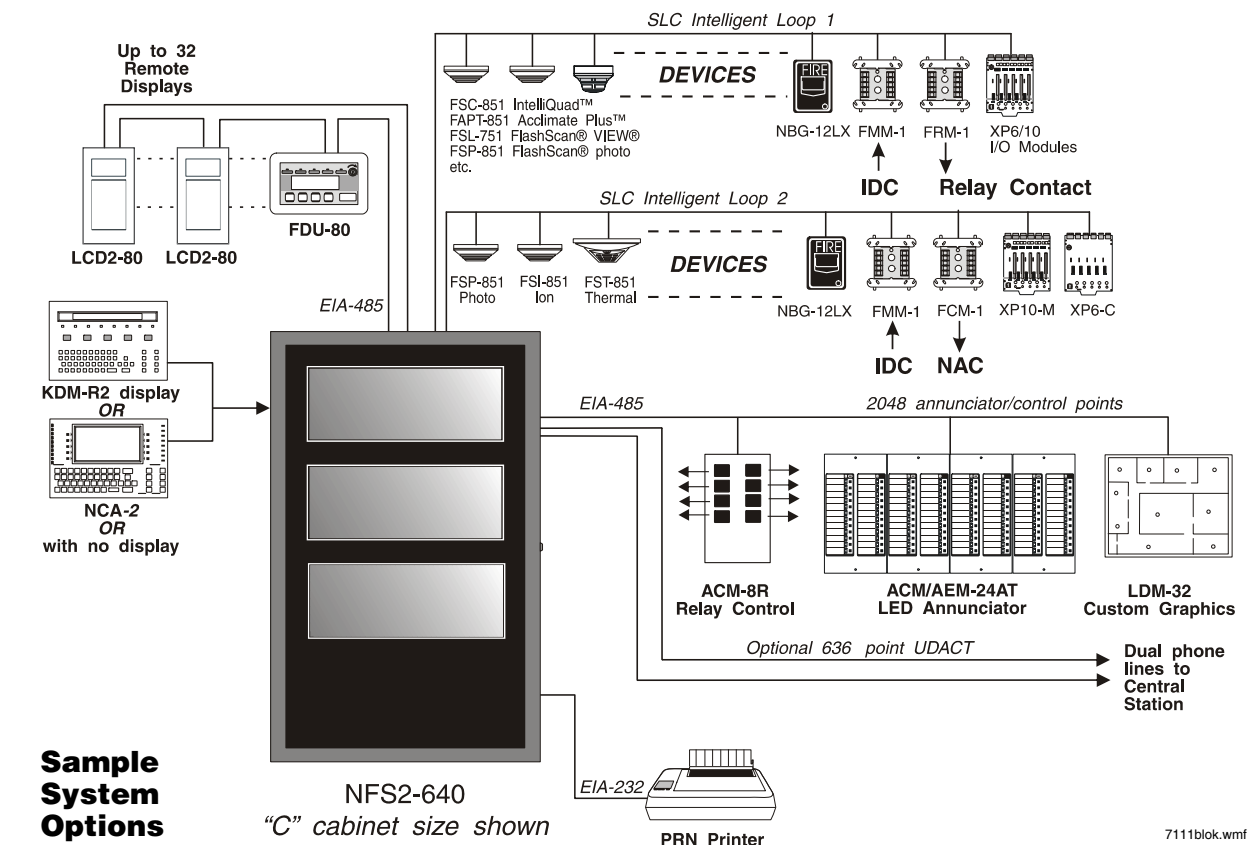

Sample System Options

NFS2-640
"C" cabinet size shown

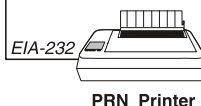

7111blok.wmf

RELEASING FEATURES

- Ten independent hazards.
- Sophisticated cross-zone (three options).
- Delay timer and Discharge timers (adjustable).
- Abort (four options).
- Low-pressure CO₂ listed.

VOICE AND TELEPHONE FEATURES

- Up to eight channels of digital audio.
- 35, 50 and, 75 watt digital amplifiers (DAA2/DAX series) (NCA-2 required as primary display).
- Solid-state digital message generation.
- Firefighter telephone option.
- 30- to 120-watt high-efficiency amplifiers (AA Series).
- Backup tone generator and amplifier option.

HIGH-EFFICIENCY OFFLINE SWITCHING

3.0 A POWER SUPPLY (6.0 A IN ALARM)

- 120 VAC (NFS2-640); 240 VAC (NFS2-640E).
- Displays battery current/voltage on panel (with display).

FlashScan, Exclusive World-Leading Detector Protocol

At the heart of the NFS2-640 is a set of detection devices and device protocol — FlashScan (U.S. Patent 5,539,389). FlashScan is an all-digital protocol that gives superior precision and high noise immunity.

In addition to providing quick identification of an active input device, this new protocol can also activate many output devices in a fraction of the time required by competitive protocols. This high speed also allows the NFS2-640 to have the largest device per loop capacity in the industry — 318 points — yet every input and output device is sampled in less than two seconds. The microprocessor-based FlashScan detectors have bicolor LEDs that can be coded to provide diagnostic information, such as device address during Walk Test.

ONYX Intelligent Sensing

Intelligent sensing is a set of software algorithms that provides the NFS2-640 with industry-leading smoke detection capability. These complex algorithms require many calculations on each reading of each detector, and are made possible by the high-speed microcomputer used by the NFS2-640.

Drift Compensation and Smoothing: Drift compensation allows the detector to retain its original ability to detect actual smoke, and resist false alarms, even as dirt accumulates. It reduces maintenance requirements by allowing the system to automatically perform the periodic sensitivity measurements required by NFPA 72. Smoothing filters are also provided by software to remove transient noise signals, such as those caused by electrical interference.

Maintenance Warnings: When the drift compensation performed for a detector reaches a certain level, the performance of the detector may be compromised, and special warnings are given. There are three warning levels: (1) Low Chamber value; (2) Maintenance Alert, indicative of dust accumulation that is near but below the allowed limit; (3) Maintenance Urgent, indicative of dust accumulation above the allowed limit.

Sensitivity Adjust: Nine sensitivity levels are provided for alarm detection. These levels can be set manually, or can change automatically between day and night. Nine levels of pre-alarm sensitivity can also be selected, based on predetermined levels of alarm. Pre-alarm operation can be latching or

self-restoring, and can be used to activate special control functions.

Self-Optimizing Pre-Alarm: Each detector may be set for “Self-Optimizing” pre-alarm. In this special mode, the detector “learns” its normal environment, measuring the peak analog readings over a long period of time, and setting the pre-alarm level just above these normal peaks.

Cooperating Multi-Detector Sensing: A patented feature of ONYX intelligent sensing is the ability of a smoke sensor to consider readings from nearby sensors in making alarm or pre-alarm decisions. Without statistical sacrifice in the ability to resist false alarms, it allows a sensor to increase its sensitivity to actual smoke by a factor of almost two to one.

Field Programming Options

Autoprogram. This timesaving feature is a special software routine. The FACP “learns” what devices are physically connected and automatically loads them in the program with default values for all parameters. Requiring less than one minute to run, this routine allows the user to have almost immediate fire protection in a new installation, even if only a portion of the detectors are installed.

Keypad Program Edit (with KDM-R2) The NFS2-640, like all NOTIFIER intelligent panels, has the exclusive feature of program creation and editing capability from the front panel keypad, while continuing to provide fire protection. The architecture of the NFS2-640 software is such that each point entry carries its own program, including control-by-event links to other points. This allows the program to be entered with independent per-point segments, while the NFS2-640 simultaneously monitors other (already installed) points for alarm conditions.

VeriFire® Tools is an offline programming and test utility that can greatly reduce installation programming time, and increase confidence in the site-specific software. It is Windows®-based and provides technologically advanced capabilities to aid the installer. The installer may create the entire program for the NFS2-640 in the comfort of the office, test it, store a backup file, then bring it to the site and download from a laptop into the panel.

Placement of Equipment in Chassis and Cabinet

The following guidelines outline the NFS2-640's flexible system design.

Rows: The first row of equipment in the cabinet mounts in the chassis shipped with the CPU. Mount the second, third, or fourth rows of equipment in a CHS-4 series chassis or, for Digital Voice Command products, in **CA-1** or **CA-2**. (For DVC and DAA2/DAX components see DVC Manual; for DVC-AO applications, see *AA Series Installation Manual*). Other options are available; see your panel's installation manual.

Wiring: When designing the cabinet layout, consider separation of power-limited and non-power-limited wiring as discussed in the *NFS2-640 Installation Manual*.

Positions: A chassis offers four basic side-by-side positions for components; the number of modules that can be mounted in each position depends on the chassis model and the size of the individual module. There are a variety of standoffs and hardware items available for different combinations and configurations of components.

It is critical that all mounting holes of the NFS2-640 are secured with a screw or standoff to ensure continuity of Earth Ground.

Layers: The CPU's chassis accepts four layers of equipment, including the control panel. The **CPU2-640** fills three positions (left to right) in the first-installed layer (the back of the chassis); its integral power supply occupies the center two positions in the next two layers; the optional display occupies (the left) two positions at the front, flush with the door. Some equipment, such as the **NCA-2**, may be mounted in the dress panel directly in front of the control panel. The NCA-2 can be used as a primary display for the NFS2-640 (use NCA/640-2-KIT) by directly connecting their network ports (required in Canadian stand-alone applications); see NCA-2 data sheet for mounting options (DN-7047).

Expansion: Installing an **LEM-320** Loop Expander Module adds a second SLC loop to the control panel. The LEM-320 is mounted onto the CPU2-640, occupying the middle-right, second (back) slot on the chassis.

Networking: If networking two or more control panels, each unit requires a Network Control Module or High-Speed Network Control Module. (HS-NCM can support two nodes; see "Networking Options" on page 4). These modules can be installed in any option board position (see manual), and additional option boards can be mounted in front of the network control modules.

KDM-R2 Controls and Indicators

Program Keypad: QWERTY type (keyboard layout, see figure).

12 LED indicators: Power; Fire Alarm; Pre-Alarm; Security; Supervisory; System Trouble; Signals Silenced; Points Disabled; Control Active; Abort; Pre-Discharge; Discharge.

Keypad Switch Controls: Acknowledge/Scroll Display; Signal Silence; Drill; System Reset; Lamp Test.

LCD Display: 80 characters (2 x 40) with long-life LED backlight.

Ordering Information

- "Configuration Guidelines" on page 4
- "Networking Options" on page 4
- "Auxiliary Power Supplies and Batteries" on page 4
- "Audio Options" on page 5
- "Compatible Devices, EIA-232 Ports" on page 5
- "Compatible Devices, EIA-485 Ports" on page 5
- "Compatible Intelligent Devices" on page 5
- "Enclosures, Chassis, and Dress Plates" on page 6
- "Other Options" on page 7

CONFIGURATION GUIDELINES

Stand-alone and network systems require a main display. On single-CPU systems (one CPU2-640/-640E), display options are the KDM-R2 or the NCA-2. On network systems (two or more networked fire panel nodes), at least one NCA-2, NCS, or ONYXWorks annunciation device is required. Other options listed as follows;

KDM-R2: 80-character backlit LCD display with QWERTY programming and control keypad. Order two BMP-1 blank modules and DP-DISP2 mounting plate separately. Requires top row of a cabinet. Required for each stand-alone 80-character display system. The KDM-R2 may mount in network nodes to display "local" node information as long as at least one NCA-2 or NCS/ONYXWorks network display is on the system to display network information.

NCA-2: Network Control Annunciator, 640 characters. On single CPU2-640/-640E systems, the optional NCA-2 can be used as the Primary Display for the panel and connects

directly to the CPU2-640/-640E. On network systems (two or more networked fire panel nodes), one network display (either NCA-2 or NCS/ONYXWorks) is required for every system. On network systems, the NCA-2 connects to (and requires) a standard Network Control Module or High-Speed Network Control Module. Mounts in a row of FACP node or in two annunciator positions. Mounting options include the DP-DISP2, ADP-4B, or in an annunciator box, such as the ABS-2D. In CAB-4 top-row applications, a DP-DISP2 and two BMP-1 blank modules are required for mounting. Required for NFS2-640 applications employing the DVC-EM with DAL devices. See DN-7047.

CPU2-640: Central processing unit with integral 3.0 A (6.0 A in alarm) power supply for an NFS2-640 system. Includes CPU factory-mounted on a chassis; one Signaling Line Circuit expandable to two; installation, programming and operating manuals. Order one per system or as necessary (up to 103 network nodes) on a network system.

CPU2-640E: Same as CPU2-640 but requires 240 VAC, 1.5 A, (3.0 A in alarm).

NCA/640-2-KIT: Bracket installation kit required to mount NCA-2 to the CPU2-640/-640E's standard chassis.

DP-DISP2: Dress panel for top row in cabinet with CPU2-640/640E installed.

ADP2-640: Dress panel for middle rows with CPU2-640/640E.

BMP-1: Blank module for unused module positions.

BP2-4: Battery plate, required.

LEM-320: Loop Expander Module. Expands each NFS2-640 to two Signaling Line Circuits. See DN-6881.

NETWORKING OPTIONS

NCM-W, NCM-F: Standard Network Communications Modules. Wire and multi-mode fiber versions available. See DN-6861.

HS-NCM-W/MF/SF/WMF/WSF/MFSF: High-speed network communications modules that can connect to two nodes. Wire, single-mode fiber, multi-mode fiber, and media conversion models are available. See DN-60454.

RPT-W, RPT-F, RPT-WF: Standard-network repeater board with wire connection (RPT-W), fiber connection (RPT-F), or allowing a change in media type between wire and fiber (RPT-WF). Not used with high-speed networks. See DN-6971.

ONYXWorks: UL-listed graphics PC workstation, software, and computer hardware. See DN-7048 for specific part numbers.

NFN-GW-EM, NFN-GW-EM-3: NFN Gateway, embedded. See DN-60499.

AUXILIARY POWER SUPPLIES AND BATTERIES

ACPS-610: 6.0 A or 10 A addressable charging power supply. See DN-60244.

APS2-6R: Auxiliary Power Supply. Provides up to 6.0 amperes of power for peripheral devices. Includes battery input and transfer relay, and overcurrent protection. Mounts on two of four positions on a CHS-4L or CHS-4 chassis. See DN-5952.

FCPS-24S6/S8: Remote 6 A and 8 A power supplies with battery charger. See DN-6927.

BAT Series: Batteries. NFS2-640 utilizes two 12 volt, 18 to 200 AH batteries. Mounts in NFS-LBB(R). See DN-6933.

AUDIO OPTIONS

NOTE: See "Enclosures, Chassis, and Dress Plates" on page 6 for mounting hardware.

DVC-EM: Digital Voice Command, digital audio processor with message storage for up to 32 minutes of standard quality (4 minutes at high quality) digital audio. Capable of playing up to eight simultaneous messages when used with Digital Audio Loop (DAL) devices. See DN-7045.

DVC-KD: Keypad for local annunciation and controls; status LEDs and 24 user-programmable buttons. See DN-7045.

DVC-AO: DVC Analog Output board provides four analog output circuits for use with AA Series amplifiers. Four-channel operation supported. See DN-7045.

DAA2-5025(E): 50W, 25 Vrms Digital Audio Amplifier assembly with power supply; includes chassis. See DN-60556.

DAA2-5070(E): 50W, 70.7 Vrms Digital Audio Amplifier assembly with power supply; includes chassis. See DN-60556.

DAA2-7525(E): 75W, 25 Vrms digital audio amplifier assembly with power supply; includes chassis. See DN-60556.

DAX-3525(E): 35W, 25 Vrms Digital Audio Amplifier assembly with power supply, includes chassis. See DN-60561.

DAX-3570(E): 35W, 70.7 Vrms Digital Audio Amplifier assembly with power supply, includes chassis. See DN-60561.

DAX-5025(E): 50W, 25 Vrms Digital Audio Amplifier assembly with power supply, includes chassis. See DN-60561.

DAX-5070(E): 50W, 70.7 Vrms Digital Audio Amplifier assembly with power supply, includes chassis. See DN-60561.

TELH-1: Firefighter's Telephone Handset for use with the DVC-EM when mounted in the CA-2 chassis. See DN-7045.

CMIC-1: Optional microphone and microphone well assembly used with the CA-1 chassis.

RM-1/RM-1SA: Remote microphone assemblies, mount on ADP-4 (RM-1) dress panel or CAB-RM/-RMR (RM-1SA) stand-alone cabinets. See DN-6728.

FTM-1: Firephone Control Module connects a remote firefighter telephone to a centralized telephone console. Reports status to panel. Wiring to jacks and handsets is supervised. See DN-6989.

AA-30: Audio Amplifier, 30 watts. Switch-mode power. Includes amplifier and audio input supervision, backup input, and automatic switchover, power supply, cables. See DN-3224.

AA-120/AA-100: Audio Amplifier provides up to 120 watts of 25 VRMS audio power for the NFS-640. The amplifier contains an integral chassis for mounting to a CAB-B4, -C4, or -D4 backbox (consumes one row). Switch-mode power. Includes audio input and amplified output supervision, backup input, and automatic switchover to backup tone. Order the AA-100 for 70.7 VRMS systems and 100 watts of power. See DN-3224.

COMPATIBLE DEVICES, EIA-232 PORTS

PRN-6: 80-column printer. See DN-6956.

VS4095/5: Printer, 40-column, 24V. Mounted in external backbox. See DN-3260.

DPI-232: Direct Panel Interface, specialized modem for extending serial data links to remotely located FACPs and/or peripherals. See DN-6870.

COMPATIBLE DEVICES, EIA-485 PORTS

ACM-24AT: ONYX Series ACS annunciator – up to 96 points of annunciation with Alarm or Active LED, Trouble LED, and switch per circuit. Active/Alarm LEDs can be programmed (by

powered-up switch selection) by point to be red, green, or yellow; the Trouble LED is always yellow. See DN-6862.

AEM-24AT: Same LED and switch capabilities as ACM-24AT, expands the ACM-24AT to 48, 72, or 96 points. See DN-6862.

ACM-48A: ONYX Series ACS annunciator – up to 96 points of annunciation with Alarm or Active LED per circuit. Active/Alarm LEDs can be programmed (by powered-up switch selection) in groups of 24 to be red, green, or yellow. Expandable to 96 points with one AEM-48A. See DN-6862.

AEM-48A: Same LED capabilities as ACM-48A, expands the ACM-48A to 96 points. See DN-6862.

ACM-8R: Remote Relay Module with eight Form-C contacts. Can be located up to 6,000 ft. (1828.8 m) from panel on four wires. See DN-3558.

LCD-80: ACS mode. 80-character, backlit LCD display. Mounts up to 6,000 ft. (1828.8 m) from panel. Up to 32 per FACP. See LCD-80/-80TM (DN-3198).

FDU-80: Terminal mode. 80-character, backlit LCD display. Mounts up to 6,000 ft. (1828.8 m) from panel. Up to 32 per FACP. See DN-6820.

LCD2-80: Terminal mode. 80-character, backlit LCD display. Mounts up to 6,000 ft. (1828.8 m) from panel. Up to 32 per FACP. See DN-60548.

LDM: Lamp Driver Modules LDM-32, LDM-E32, and LDM-R32; remote custom graphic driver modules. See DN-0551.

SCS: Smoke control stations SCS-8, SCE-8, with lamp drivers SCS-8L, SCE-8L; eight (expandable to 16) circuits. See DN-4818.

TM-4: Transmitter Module. Includes three reverse-polarity circuits and one municipal box circuit. Mounts in panel module position (single-address-style) or in CHS2-M2 position. See DN-6860.

UDACT: Universal Digital Alarm Communicator Transmitter, 636 channel. See DN-4867.

UZC-256: Programmable Universal Zone Coder provides positive non-interfering successive zone coding. Microprocessor-controlled, field-programmable from IBM®-compatible PCs (requires optional programming kit). Up to 256 programmable codes. Mounts in **BB-UZC** or other compatible chassis (purchased separately). See DN-3404.

COMPATIBLE INTELLIGENT DEVICES

BEAMHK: Heating kit for transmitter/receiver unit of FSB-200(S) below. See DN-6985.

BEAMHKR: Heating kit for use with the reflector of FSB-200(S) below. See DN-6985.

BEAMLRK: Long-range accessory kit, FSB-200(S) below. See DN-6985.

BEAMMKR: Multi-mount kit, FSB-200(S) below. See DN-6985.

BEAMSMK: Surface-mount kit, FSB-200(S) below. See DN-6985.

FSB-200: Intelligent beam smoke detector. See DN-6985.

FSB-200S: Intelligent beam smoke detector with integral sensitivity test. See DN-6985.

FSC-851: FlashScan IntelliQuad Advanced Multi-Criteria Detector. See DN-60412.

FSI-851: Low-profile FlashScan ionization detector. See DN-6934.

FSP-851: Low-profile FlashScan photoelectric detector. See DN-6935.

FSP-851T: FSP-851 plus dual electronic thermistors that add 135°F (57°C) fixed-temperature thermal sensing. *See DN-6935.*

FSP-851R: FSP-851, remote-test capable. For use with DNR(W). *See DN-6935.*

FST-851: FlashScan thermal detector 135°F (57°C). *See DN-6936.*

FST-851R: FlashScan thermal detector 135°F (57°C) with rate-of-rise. *See DN-6936.*

FST-851H: FlashScan 190°F (88°C) high-temperature thermal detector. *See DN-6936.*

FAPT-851: FlashScan Acclimate Plus low-profile multi-sensor detector. *See DN-6937.*

FSL-751: FlashScan VIEW laser photo detector. *See DN-6886.*

DNR: InnovairFlex low-flow non-relay duct-detector housing (order FSP-851R separately). Replaces FSD-751PL/FSD-751RPL. *See DN-60429.*

DNRW: Same as above with NEMA-4 rating, watertight. *See DN-60429.*

B224RB: Low-profile relay base. *See DN-60054.*

B224BI: Isolator base for low-profile detectors. *See DN-60054.*

B210LP: Low-profile base. Standard U.S. style. Replaces B710LP. *See DN-60054.*

B501: European-style, 4" (10.16 cm) base. *See DN-60054.*

B200S: Intelligent addressable sounder base, capable of producing a variety of tone patterns including ANSI Temporal 3. Compatible with synchronization protocol. *See DN-60054.*

B200SR: Sounder base, Temporal 3 or Continuous tone. *See DN-60054.*

FMM-1: FlashScan monitor module. *See DN-6720.*

FDM-1: FlashScan dual monitor module. *See DN-6720.*

FZM-1: FlashScan two-wire detector monitor module. *See DN-6720.*

FMM-101: FlashScan miniature monitor module. *See DN-6720.*

FCM-1: FlashScan NAC control module. *See DN-6720.*

FCM-1-REL: FlashScan releasing control module. *See DN-60390.*

FRM-1: FlashScan relay module. *See DN-6720.*

NBG-12LX: Manual pull station, addressable. *See DN-6726.*

ISO-X: Isolator module. *See DN-2243. See DN-2243.*

XP6-C: FlashScan six-circuit supervised control module. *See DN-6924.*

XP6-MA: FlashScan six-zone interface module; connects intelligent alarm system to two-wire conventional detection zone. *See DN-6925.*

XP6-R: FlashScan six-relay (Form-C) control module. *See DN-6926.*

XP10-M: FlashScan ten-input monitor module. *See DN-6923.*

ENCLOSURES, CHASSIS, AND DRESS PLATES

CAB-4 Series Enclosure: NFS2-640 mounts in a standard CAB-4 Series enclosure (available in four sizes, "A" through "D"). Backbox and door ordered separately; requires BP2-4 battery plate. A trim ring option is available for semi-flush mounting. *See DN-6857.*

EQ Series Cabinets: EQ series cabinets will house amplifiers, power supplies, battery chargers and control modules. EQ cabinets are available in three sizes, "B" through "D". *See DN-60229.*

CHS-4: Chassis for mounting up to four APS-6Rs.

CHS-4L: Low-profile four-position Chassis. Mounts two AA-30 amplifiers or one AMG-E and one AA-30.

DP-1B: Blank dress panel. Provides dead-front panel for unused tiers; covers DAA2-series or AA-series amplifier.

NFS-LBB: Battery Box (required for batteries larger than 26 AH).

NFS-LBBR: Same as above but red.

CHS-BH1: Battery chassis; holds two 12.0 AH batteries. Mounts one the left side of DAA2 chassis. *See DN-7046.*

CA-1: Chassis, occupies one tier of a CAB-4 Series enclosure. The left side accommodates one DVC and a DVC-KD (optional); and the right side houses a CMIC-1 microphone and its well (optional). *See DN-7045.*

CA-2: Chassis assembly, occupies two tiers of a CAB-4 Series enclosure. The left side accommodates one DVC mounted on a half-chassis and one NFS2-640 or NCA-2 mounted on a half-chassis. The right side houses a microphone/handset well. The CA-2 assembly includes CMIC-1 microphone. ADDR Series doors with two-tier visibility are available for use with the CA-2 configuration: ADDR-B4, ADDR-C4, ADDR-D4 (below).

CFFT-1: Chassis to mount firefighters telephone and one ACS annunciator in a CAB-4 row. Includes TELH-1 firefighters handset for the DVC, chassis, phone well and mounting hardware. Order DP-CFFT dress panel separately.

DP-CFFT: CFFT-1 dress panel. Requires BMP-1 if no ACS annunciator is installed.

ADDR-B4*: Two-tier-sized door designed for use with the CA-2 chassis configuration. ADDR Series doors are similar to CAB-4 Series "DR" doors, but a clear window space exposes the top two tiers of the CAB-4 enclosure. Use an SBB-B4 backbox with the ADDR-B4. *See DN-7045, DN-6857.*

ADDR-C4*: Three-tier-sized door, designed for use with the CA-2 chassis configuration. ADDR Series doors are similar to CAB-4 Series "DR" doors, but a clear window space exposes the top two tiers of the CAB-4 enclosure. Use an SBB-C4 backbox with the ADDR-C4. *See DN-7045, DN-6857.*

ADDR-D4*: Four-tier-sized door designed for use with the CA-2 chassis configuration. ADDR Series doors are similar to CAB-4 Series "DR" doors, but a clear window space exposes the top two tiers of the CAB-4 enclosure. Use an SBB-D4 backbox with the ADDR-D4. *See DN-7045, DN-6857.*

*Use ADDR-B4/C4/D4 when CA-2 chassis is installed in top two rows with NCA-2 or BP-CA2. Use standard door when CA-2 is not installed in top two rows. Please see the DVC application guide for additional configuration information.

DPA-1: Dress panel, used with the CA-1 chassis when configured with a DVC, DVC-KD, and CMIC-1. *See DN-7045.*

DPA-2B: Dress panel used with CA-2 chassis assembly.

VP-2B: Dress panel, required when CA-2 chassis is installed in the top two cabinet rows.

DPA-1A4: Dress panel, used with the CA-1 chassis when the CMIC-1 is not used. Provides mounting options on right two bays for two ACS annunciators, or for blank plates. *See DN-7045.*

BP-CA2: Blank plate for CA-2 chassis.

BB-UZC: Backbox for housing the UZC-256 in applications where the UZC-256 will not fit in panel enclosure. Black; for red, order BB-UZC-R.

SEISKIT-CAB: Seismic mounting kit. Required for seismic-certified applications with NFS2-640 and BB-26. Includes battery bracket for two 26 AH batteries.

SEISKIT-LBB: Seismic kit for the NFS-LBB. Includes battery bracket for two 55 AH batteries.

SEISKIT-PS/2/4: Seismic mounting kit for the FCPS-24S6/S8 and CAB-PS1. Includes battery bracket for two 7 AH or 12 AH batteries.

OTHER OPTIONS

411: Slave digital alarm communicator. See DN-6619.

411UDAC: Digital alarm communicator. See DN-6746.

IPDACT-2/2UD, IPDACT Internet Monitoring Module: Connects to primary and secondary DACT telephone output ports for internet communications over customer-provided ethernet connection. Requires compatible Teldat VisorALARM Central Station Receiver. Can use DHCP or static IP. See *DN-60408*.

IPCHSKIT: IP Communicator Chassis Mounting Kit. For mounting an IPDACT-2/2UD onto the panel chassis or CHS-4 series chassis. Use IPENC for external mounting applications.

IPSPLT: Y-adaptor option allow connection of both panel dialer outputs to one IPDACT-2/2UD cable input.

IPENC: External enclosure for IPDACT, includes IPBRKT mounting bracket; Red. For Black order IPENC-B.

IPGSM-COM: Internet and Digital Cellular Fire Communicator Panel. Uses internet as primary with dual GSM technology as backup. Connects to the primary and secondary ports of a DACT. See *DN-60656*.

VeriFire-TCD:: VeriFire Tools programming software for the ONYX Series. Includes local panel connection cable. See *DN-6871*.

VeriFireUG-TCD: VeriFire Tools upgrade software.

NOTE: For other options including compatibility with retrofit equipment, refer to the panel's installation manual, the SLC manual, and the Device Compatibility Document.

SYSTEM SPECIFICATIONS

System Capacity

- Intelligent Signaling Line Circuits 1 expandable to 2
- Intelligent detectors 159 per loop
- Addressable monitor/control modules 159 per loop
- Programmable software zones 99
- Special programming zones 14
- LCD annunciators per CPU2-640/-640E and NCA-2 (*observe power*) 32
- ACS annunciators per CPU2-640/-640E 32 addresses x 64 points
- ACS annunciators per NCA-2 32 addresses x 64 or 96 points

NOTE: The NCA-2 supports up to 96 annunciator address points per ACM-24AT/-48A.

Specifications

- Primary input power:
 - CPU2-640 board: 120 VAC, 50/60 Hz, 5.0 A.
 - CPU2-640E board: 220/240 VAC, 50/60 Hz, 2.5 A.
- Total output 24 V power: 6.0 A in alarm.

NOTE: The power supply has a total of 6.0 A. of available power. This is shared by all internal circuits.

- Standard notification circuits (4): 1.5 A each.
- Resettable regulated 24V power: 1.25 A.
- Two non-resettable regulated 24V power outputs:
 - 1.25 A.
 - 0.50 A.
- Non-resettable 5V power: 0.15 A.
- Battery charger range: 18 AH – 200 AH. Use separate cabinet for batteries over 26 AH.
- Float rate: 27.6 V.

Cabinet Specifications

Systems can be installed in CAB-4 Series cabinets (*four sizes with various door options, see DN-6857*). Requires BP2-4 Battery Plate.

Shipping Weight

- CPU2-640/-640: 14.3 lb (6.49 kg).
- CPU2-640/-640E: 14.55 lb (6.60 kg).

Temperature and Humidity Ranges

This system meets NFPA requirements for operation at 0 – 49°C/32 – 120°F and at a relative humidity 93% ± 2% RH

(noncondensing) at 32°C ± 2°C (90°F ± 3°F). However, the useful life of the system's standby batteries and the electronic components may be adversely affected by extreme temperature ranges and humidity. Therefore, it is recommended that this system and its peripherals be installed in an environment with a normal room temperature of 15 – 27°C/60 – 80°F.

Agency Listings and Approvals

The listings and approvals below apply to the basic NFS2-640 control panel. In some cases, certain modules may not be listed by certain approval agencies, or listing may be in process. Consult factory for latest listing status.

- **UL Listed:** S635
- **ULC Listed:** S635
- **FM Approved**
- **MEA:** 128-07-E
- **FDNY:** COA# 6067
- **CSFM:** 7165-0028:0243
- **City of Chicago**
- **City and County of Denver**
- **CCCF listed**

Standards

The NFS2-640 complies with the following UL Standards and NFPA 72, IBC, and CBC Fire Alarm Systems requirements:

- **UL 864, 9th Edition** (Fire).
- **UL 1076** (Burglary).
- **LOCAL** (Automatic, Manual, Waterflow and Sprinkler Supervisory).
- **AUXILIARY** (Automatic, Manual and Waterflow) (requires TM-4).
- **REMOTE STATION** (Automatic, Manual, Waterflow and Sprinkler Supervisory) (requires TM-4).
- **PROPRIETARY** (Automatic, Manual and Waterflow). *Not applicable for FM.*
- **EMERGENCY VOICE/ALARM.**
- **OT, PSDN** (Other Technologies, Packet-switched Data Network).
- **IBC 2000, IBC 2003, IBC 2006, IBC2009** (Seismic).
- **CBC 2007** (Seismic).

NOTI•FIRE•NET™, **IntelliQuad™**, and **ONYXWorks™** are trademarks; and **Acclimate® Plus™**, **FlashScan®**, **NOTIFIER®**, **ONYX®**, **VeriFire®**, and **VIEW®** are registered trademarks of Honeywell International Inc. **Microsoft®** and **Windows®** are registered trademarks of Microsoft Corporation. **IBM®** is a registered trademark of IBM Corporation.

©2011 by Honeywell International Inc. All rights reserved. Unauthorized use of this document is strictly prohibited.



This document is not intended to be used for installation purposes. We try to keep our product information up-to-date and accurate. We cannot cover all specific applications or anticipate all requirements. All specifications are subject to change without notice.



Made in the U.S.A.

➤ CAB-4 Series Cabinets

ONYX® Series Backboxes with Locking Doors



Peripheral Devices

General

All cabinets for NOTIFIER fire alarm control panels are fabricated from 16-gauge steel. The cabinet assembly consists of two basic parts: a backbox and a locking door. Cabinets are available in either black or red, with or without LEXAN® windows. The LEXAN model provides a tasteful combination to accent the decor of the finest lobby setting.

- The **key-locked door** is provided with a pin-type hinge, two keys and the necessary hardware to mount the door to the backbox.
- The **backbox** has been engineered to provide ease-of-entry for the installer. **Knockouts** are positioned at numerous points to aid the installer in bringing a conduit into the enclosure with a minimum of hardship.
- **Right- or left-hand hinges**, selectable in the field. Door opens 180°.
- Cabinets are arranged in **four standard sizes**, A (one tier) through D (four tiers), plus a **mini cabinet** (AA, one tier without a battery compartment). See *Ordering Information*.
- A **trim ring option** is available for semi-flush mounting.
- **Chassis bridge** available for assembling multiple CHS-4 chassis external to the backbox.

Ordering Information

A complete cabinet assembly consists of: a door, a backbox, an optional battery plate, and an optional semi-flush trim ring. For each cabinet required, order one "DR" door and one "SBB" backbox. The BP-4 or BP2-4 battery plate is required for each cabinet assembly that mounts batteries and/or a power supply in the lower position of the cabinet. The optional trim ring is an attractive "picture frame"-style black metal ring.

MINI "AA" SIZE, ONE TIER:

DR-AA4: Door assembly, LEXAN window, one tier (no battery compartment), BLACK.

DR-AA4R: Door assembly, LEXAN window, one tier (no battery compartment), RED.

DR-AA4B: Door assembly, solid door, one tier (no battery compartment), BLACK.

DR-AA4BR: Door assembly, solid door, one tier (no battery compartment), RED.

SBB-AA4: Backbox assembly, one tier (no battery compartment), BLACK.

SBB-AA4R: Backbox assembly, one tier (no battery compartment), RED.

TR-AA4: Accessory semi-flush-mount trim ring, one tier (no battery compartment).

NOTE: Black trim rings are used with red or black cabinets.

ONE TIER, "A" SIZE:

DR-A4: Door assembly, LEXAN window, one tier, BLACK.

DR-A4R: Door assembly, LEXAN window, one tier, RED.

DR-A4B: Door assembly, solid door, one tier, BLACK.

DR-A4BR: Door assembly, solid door, one tier, RED.

SBB-A4: Backbox assembly, one tier, BLACK.

SBB-A4R: Backbox assembly, one tier, RED.



NFS-640 in "B" sized
CAB-4 cabinet

TR-A4: Accessory semi-flush-mount trim ring, one tier (opening 24.062" [61.118 cm] W x 20.062" [50.958 cm] H), BLACK.

NOTE: Black trim rings are used with red or black cabinets.

BP-4: Battery panel for NFS-640 and NFS-3030. Used to cover battery and power supply when lower position is used in backbox.

BP2-4: Battery panel for NFS2-3030. Used to cover battery and power supply when lower position is used in backbox.

TWO TIERS, "B" SIZE:

DR-B4: Door assembly, LEXAN window, two tiers, BLACK.

DR-B4R: Door assembly, LEXAN window, two tiers, RED.

DR-B4B: Door assembly, solid door, two tiers, BLACK.

DR-B4BR: Door assembly, solid door, two tiers, RED.

SBB-B4: Backbox assembly, two tiers, BLACK.

SBB-B4R: Backbox assembly, two tiers, RED.

TR-B4: Accessory semi-flush-mount trim ring, two tiers (opening 24.062" [61.118 cm] W x 28.562" [72.548 cm] H), BLACK.

NOTE: Black trim rings are used with red or black cabinets.

BP-4: Battery panel for NFS-640 and NFS-3030. Used to cover battery and power supply when lower position is used in backbox.

BP2-4: Battery panel for NFS2-3030. Used to cover battery and power supply when lower position is used in backbox.

THREE TIERS, "C" SIZE:

➤ **DR-C4:** Door assembly, LEXAN window, three tiers, BLACK.

DR-C4R: Door assembly, LEXAN window, three tiers, RED.

DR-C4B: Door assembly, solid door, three tiers, BLACK.

DR-C4BR: Door assembly, solid door, three tiers, RED.

➤ **SBB-C4:** Backbox assembly, three tiers, BLACK.

SBB-C4R: Backbox assembly, three tiers, RED.

TR-C4: Accessory semi-flush-mount trim ring, three tiers (opening 24.062" [61.118 cm] W x 37.187" [94.455 cm] H), BLACK.

NOTE: Black trim rings are used with red or black cabinets.

BP-4: Battery panel for NFS-640 and NFS-3030. Used to cover battery and power supply when lower position is used in backbox.

BP2-4: Battery panel for NFS2-3030. Used to cover battery and power supply when lower position is used in backbox.

FOUR TIERS, "D" SIZE:

DR-D4: Door assembly, LEXAN window, four tiers, BLACK.

DR-D4R: Door assembly, LEXAN window, four tiers, RED.

DR-D4B: Door assembly, solid door, four tiers, BLACK.

DR-D4BR: Door assembly, solid door, four tiers, RED.

SBB-D4: Backbox assembly, four tiers, BLACK.

SBB-D4R: Backbox assembly, four tiers, RED.

TR-D4: Accessory semi-flush-mount trim ring, four tiers (opening 24.062" [61.118 cm] W x 45.812" [116.363 cm] H), BLACK.

Note: Black trim rings are used with red or black cabinets.

BP-4: Battery panel for NFS-640 and NFS-3030. Used to cover battery and power supply when lower position is used in backbox.

BP2-4: Battery panel for NFS2-3030. Used to cover battery and power supply when lower position is used in backbox.

ACCESSORIES:

WC-2: Wire channel. Provides a pair of wire trays to neatly route wiring between CHS chassis.

CB-1: Chassis bridge. Provides a bridge between CHS Series chassis.

DP-1B: Blank dress panel, covers one CAB-4 tier, BLACK.

ADP-4B: Annunciator dress panel.

Agency Listings and Approvals

These listings and approvals below apply to the CAB-4 Series Cabinets. In some cases, certain modules or applications may not be listed by certain approval agencies, or listing may be in process. Consult factory for latest listing status.

- **UL** Listed: file S635 (except AA size).
- **ULC** Listed: file CS118 (except AA size).
- **MEA** approved: files 317-01-E, 345-02-E (except AA size).
- **CSFM** approved (except AA size): files 7165-0028:214 (NFS-640), 7170-0028:216 (NFS-640), 7165-0028:224 (NFS-3030), 7170-0028:223 (NFS-3030).
- **FM** approved (except AA size).
- **U.S. Coast Guard** approved: 161.002/42/1 (NFS-640).

Cabinet Dimensions and Features

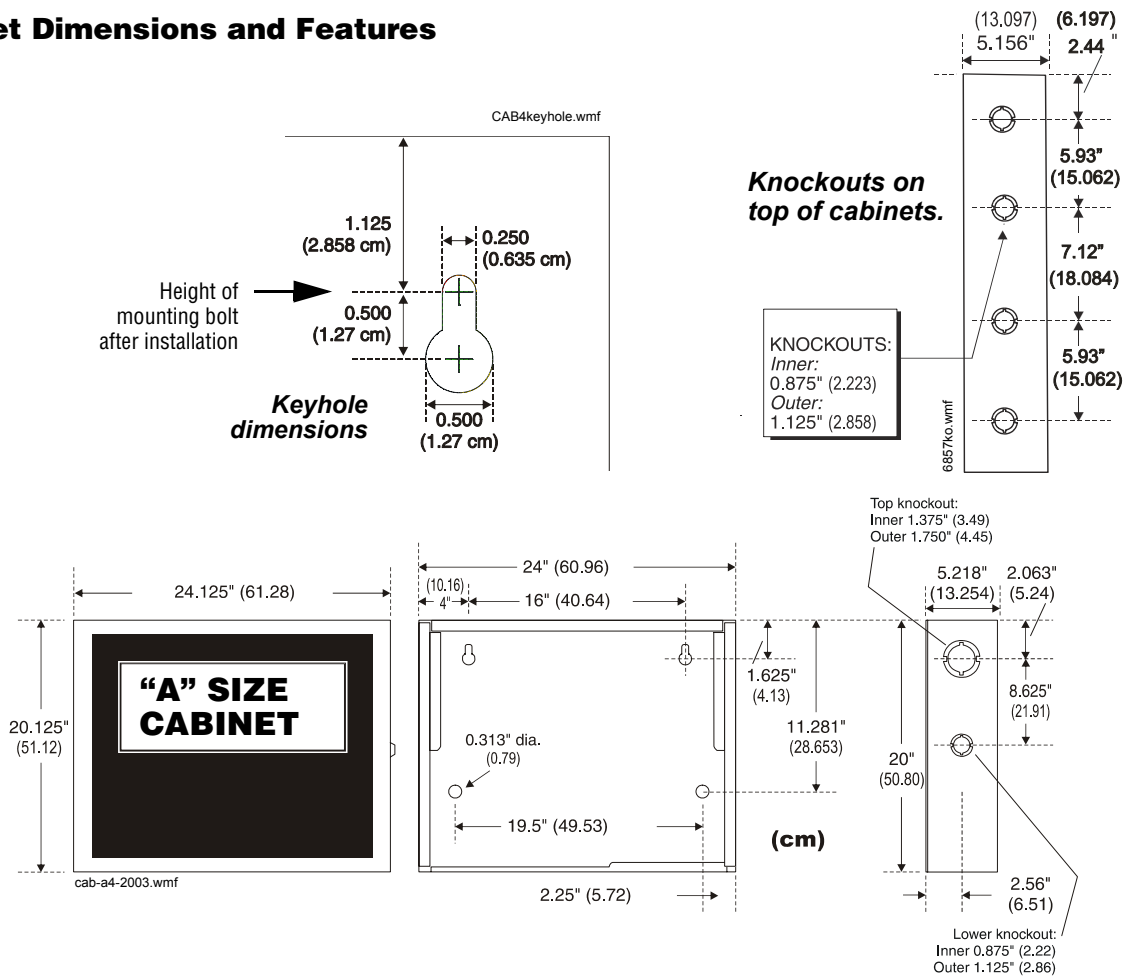

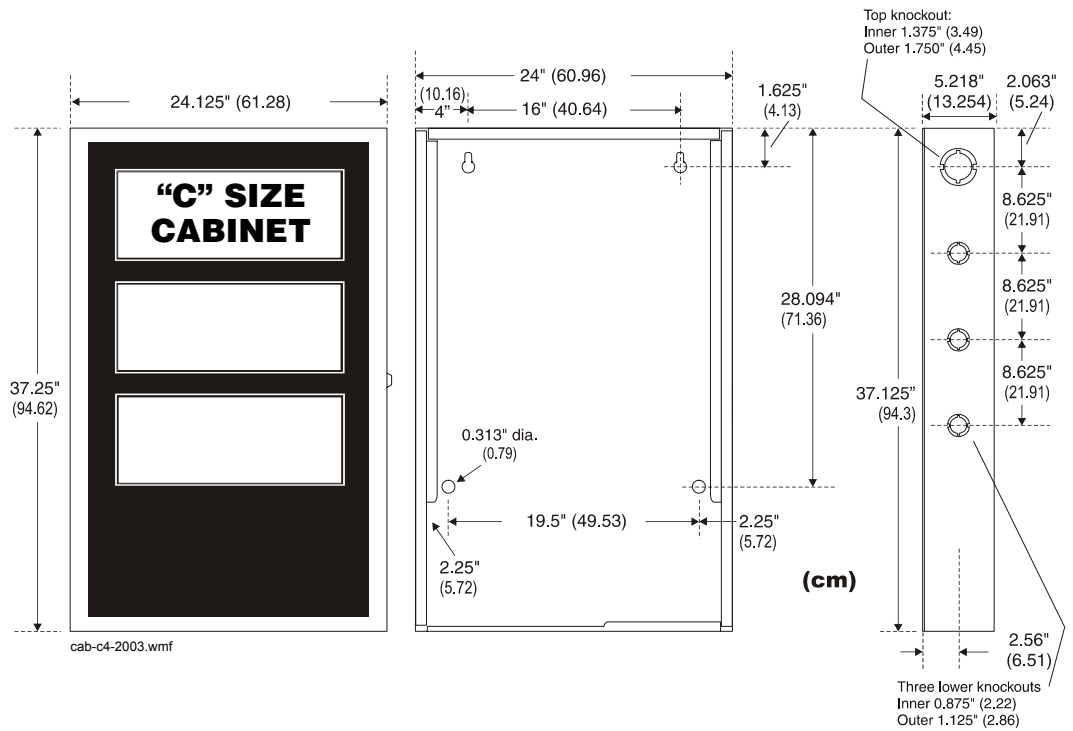
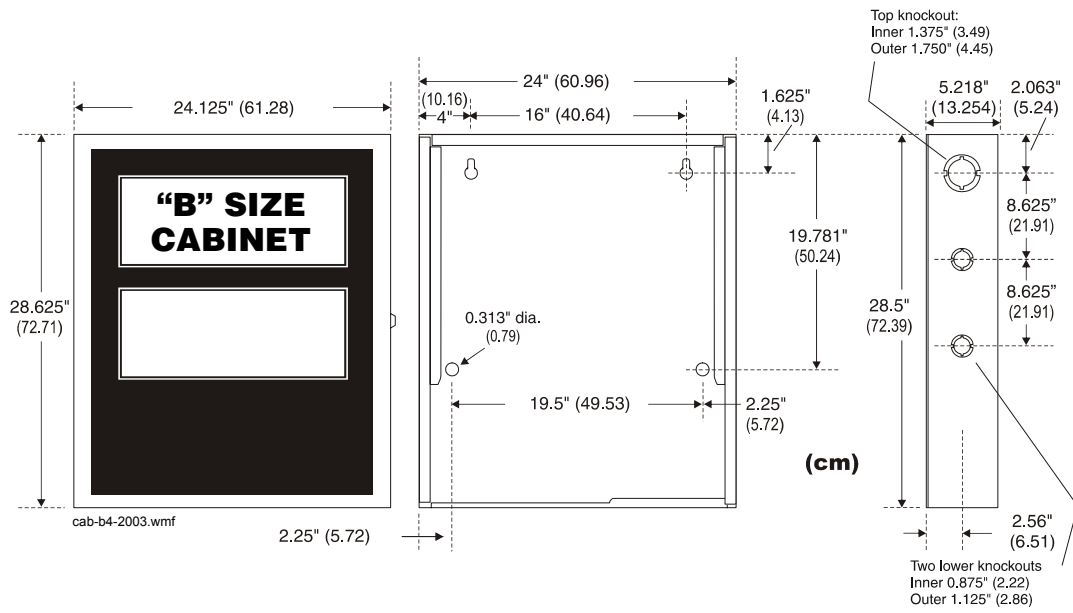
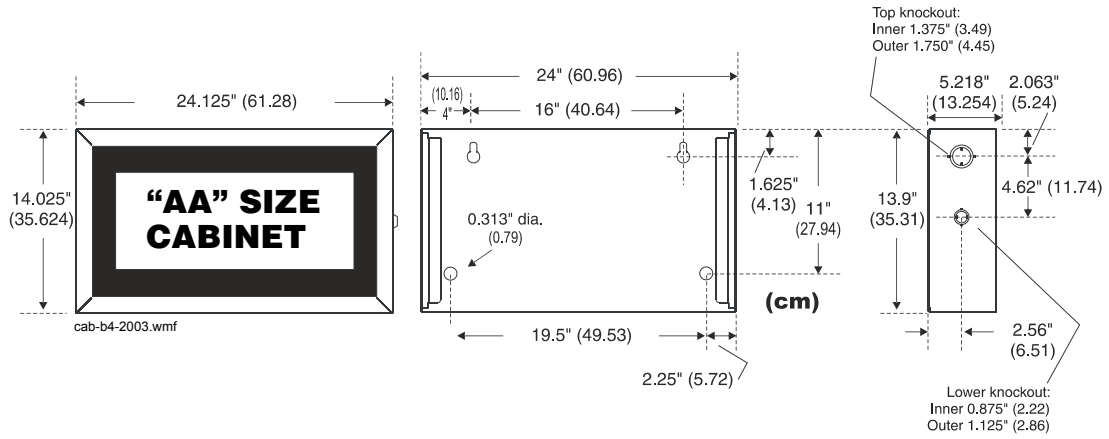

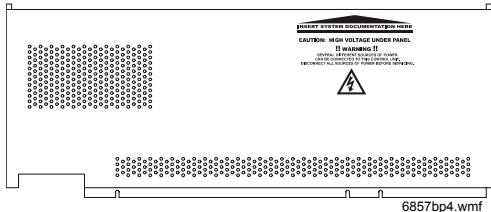
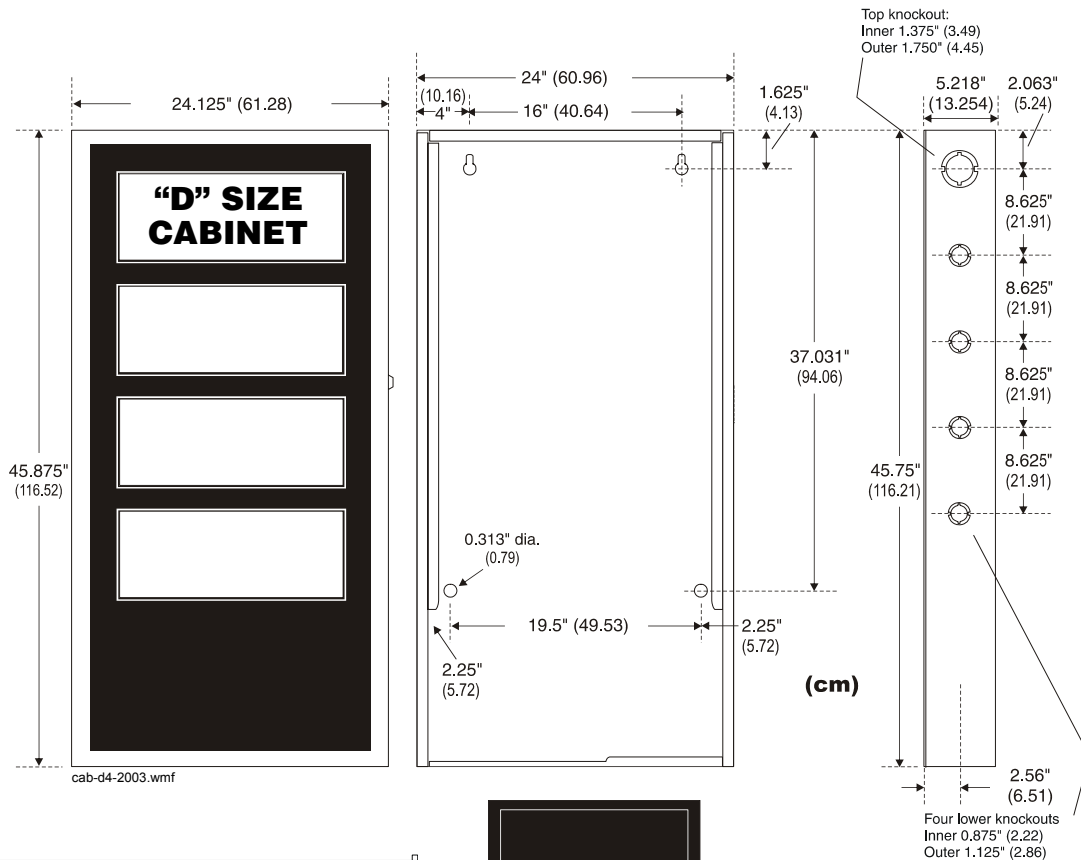

The BP-4 Battery Dress Panel covers the Main Power Supply and the batteries in the cabinet. Only one BP-4 or BP2-4 is required per cabinet unless an AA cabinet is used (no battery compartment).

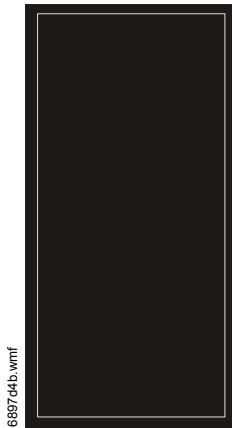

"D" sized cabinet with solid door. Solid door option available on all sizes in black or red.

ONYX® and NOTIFIER® are registered trademarks of Honeywell International Inc. LEXAN® is a registered trademark of GE Plastics, a subsidiary of General Electric Company.
©2006 by Honeywell International Inc. All rights reserved. Unauthorized use of this document is strictly prohibited.



This document is not intended to be used for installation purposes. We try to keep our product information up-to-date and accurate. We cannot cover all specific applications or anticipate all requirements. All specifications are subject to change without notice.



BAT Series Batteries

Sealed Lead-Acid or Gell Cell

Power Supplies

General

BAT Series Batteries feature a new part-numbering/listing system — providing an improved method of delivery for NOTIFIER-approved sealed lead-acid batteries for all your fire alarm system needs. Multiple brands of batteries are now offered under generic part numbers, reducing backorder situations and permitting us to deliver these products in a more timely fashion. NOTIFIER has approved the multiple brands listed below as possible product shipped for a given part number. Please note that any incoming orders for “PS Series” batteries will be converted to the equivalent BAT Series part numbers.



6933cov.jpg

Features

- Provide secondary power for control panels.
- Sealed and maintenance-free.
- Overcharge protected.
- Easy handling with leakproof construction.
- Ruggedly constructed, high-impact case (ABS, polystyrene, or polypropylene, depending on models).
- Long service life.
- Compact design.

Agency Listings and Approvals

The listings and approvals below apply to BAT Series Batteries. In some cases, certain modules may not be listed by certain approval agencies, or listing may be in process. Consult factory for latest listing status.

- **UL Recognized Components:** files MH19884 (*B & B Battery*), MH20567 (*UPG, previously Jolt*), MH20845 (*Power-Sonic*).

Part Number Reference

CURRENT Part Number	BATTERY DESCRIPTION	ALTERNATES APPROVED: manufacturers and P/Ns shipped under BAT P/Ns
BAT-1250	12 V, 5 AH, sealed.	BP5-12 (B&B Battery); PS-1250 (Power-Sonic); SA1250 (Jolt) to be replaced with UB1250 (UPG).
BAT-1250	12 V, 5 AH, sealed.	BP5-12 (B&B Battery); PS-1250 (Power-Sonic); SA1250 (Jolt) to be replaced with UB1250 (UPG).
BAT-1270	12 V, 7 AH, sealed.	BP7-12 (B&B Battery); PS-1270 (Power-Sonic); SA1272 (Jolt) to be replaced with UB1270 (UPG).
BAT-12120	12 V, 12 AH, sealed.	BP12-12 (B&B Battery); PS-12120 (Power-Sonic); SA12120 (Jolt) to be replaced with UB12120 (UPG).
BAT-12180	12 V, 18 AH, sealed.	PS-12180 (Power-Sonic); SA12180 (Jolt) to be replaced with UB12180 (UPG).
BAT-12180	12 V, 18 AH, sealed.	PS-12180 (Power-Sonic); SA12180 (Jolt) to be replaced with UB12180 (UPG).
BAT-12260	12 V, 26 AH, sealed.	BP26-12 (B&B Battery); PS-12260 (Power-Sonic); SA12260 (Jolt) to be replaced with UB12260 (UPG).
BAT-12550	12 V, 55 AH, sealed.	PS-12550 (Power-Sonic); XSA12550 (Jolt) to be replaced with UB12550 (UPG).
BAT-12550	12 V, 55 AH, sealed.	PS-12550 (Power-Sonic); XSA12550 (Jolt) to be replaced with UB12550 (UPG).
BAT-121000	12 V, 100 AH, gell cell.	PS-121000 (Power-Sonic); XSA121000A (Jolt) to be replaced with UB121000 (UPG).

POWER-SONIC

Part Number Reference

1109t1.tbl

MODEL	Nominal Voltage V	Nominal Capacity @ 20 hr. rate A.H.	Discharge Current @20 hr. rate mA	DIMENSIONS									
				Width		Depth		Height		Height over terminal		Weight	
				in.	mm	in.	mm	in.	mm	in.	mm	lb.	kg.
PS-1250	12	5	250	3.54	90	2.76	70	4.02	102	4.21	107	4.1	1.9
PS-1270	12	7	325	5.94	151	2.56	65	3.7	94	3.86	98	5.7	2.6
PS-12120	12	12	600	5.94	151	3.86	98	3.7	94	3.86	98	8.8	4
PS-12180	12	18	875	7.13	181	2.99	76	6.57	167	6.57	167	12.8	5.8
PS-12250	12	25	1300	6.89	175	6.54	166	4.92	125	4.92	125	18.7	8.5
PS-12550	12	55	3000	10.25	260	6.6	168	8.2	208	9.45	240	39.7	18
PS-121000	12	100	5000	12	305	6.6	168	8.2	208	9.45	240	65.7	29.8

Characteristic Discharge Curves

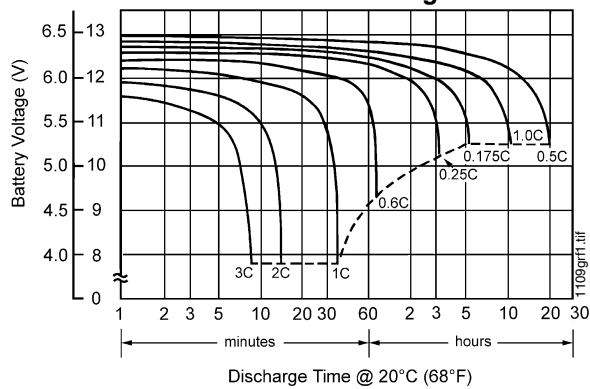

Effect of Temperature on Capacity

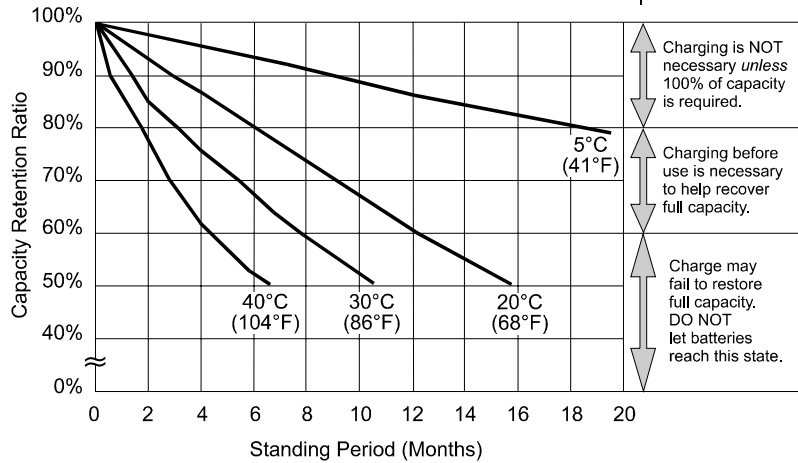
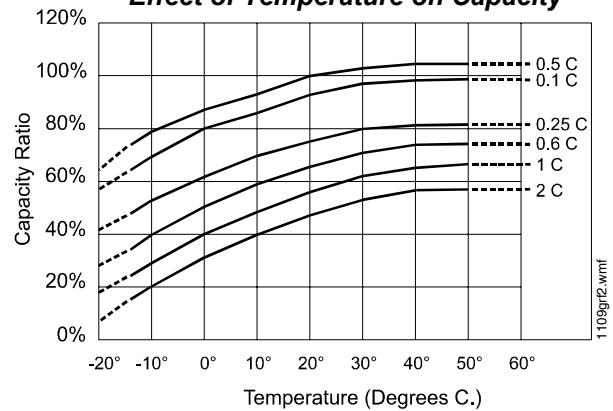

**at left:
PS-121000
Shelf-Life
and Storage**

Charging is NOT necessary unless 100% of capacity is required.

Charging before use is necessary to help recover full capacity.

Charge may fail to restore full capacity. DO NOT let batteries reach this state.

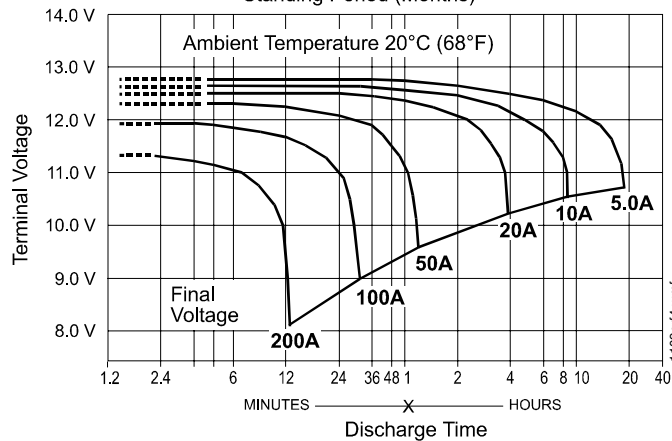

**at left:
PS-121000
Discharge
Characteristics**

B & B BATTERY

Model	V	Nominal Capacity (AH)				Weight		Terminal				Dimensions							
								Standard		Optional		L		W		H		TH	
		20 hr	10 hr	5 hr	1 hr	kg	lbs	Type	Pos.	Type	Pos.	mm	in	mm	in	mm	in	mm	in
BP5-12	12	5.00	4.75	4.25	3.00	1.86	4.10	T1	3	T2		90	3.54	70	2.76	102	4.02	106	4.17
BP7-12	12	7.00	6.65	5.95	4.20	2.60	5.73	T2	5	T1		151	5.94	65	2.56	93	3.66	98	3.86
BP12-12	12	12.00	11.40	10.20	7.20	4.03	8.89	B1	5	T1		151	5.94	98	3.86	94	3.70	98	3.86
BP26-12	12	26.00	24.70	22.10	15.60	9.40	20.73	B1	7	T2.11	9	175	6.89	166	6.54	125	4.92	125	4.92

Charging Procedure

Application	Charging method	Charging voltage at 20°C (V/cell)	Temperature compensation coefficient of charging voltage (mV/°C/cell)	Maximum charging current (CA)	Charging time 0.1 CA, 20°C (h)		Temp (°C)
					100% discharge	50% discharge	
For standby power source	Constant voltage and constant current charging (with current restriction)	2.25 ~ 2.30	- 3	0.3	24	20	0 - 40°C (32 ~ 104°F)
For cycle service		2.40 ~ 2.50	- 4	0.3	16	10	

Temperature compensation of charging voltage is not needed when using the batteries within 5°C to 35°C range.

Final Voltage	Discharge Time: for Model BP5-12								
	5 min	10 min	15 min	30 min	1 hr	3 hr	5 hr	10 hr	20 hr
	Battery Output Power (W): for Model BP5-12								
10.80 V	180.8	133.1	106.6	63.5	36.39	14.57	10.05	5.62	2.94
10.50 V	209.2	144.2	111.5	65.9	37.48	14.87	10.20	5.70	3.00
10.20 V	222.3	149.4	115.0	67.4	38.16	15.00	10.26	5.73	3.01
9.90 V	232.3	152.9	117.6	68.3	38.61	15.10	10.29	5.75	3.02
9.60 V	240.0	156.0	120.0	69.0	39.0	15.20	10.32	5.75	3.02

Constant Power Discharge Characteristics at 25°C/77°F for BP5-12

Final Voltage	Discharge Time: for Model BP7-12								
	5 min	10 min	15 min	30 min	1 hr	3 hr	5 hr	10 hr	20 hr
	Battery Output Power (W): for Model BP7-12								
10.80 V	253.1	186.3	149.3	88.8	50.95	20.40	14.07	7.86	4.11
10.50 V	292.9	201.8	156.2	92.2	52.47	20.81	14.28	7.98	4.20
10.20 V	311.2	209.1	161.0	94.3	53.42	21.00	14.36	8.02	4.22
9.90 V	325.2	214.1	164.7	95.6	54.06	21.15	14.41	8.04	4.23
9.60 V	336.0	218.4	168.0	96.6	54.60	21.27	14.45	8.04	4.23

Constant Power Discharge Characteristics at 25°C/77°F for BP7-12

Final Voltage	Discharge Time: for Model BP12-12								
	5 min	10 min	15 min	30 min	1 hr	3 hr	5 hr	10 hr	20 hr
	Battery Output Power (W): for Model BP12-12								
10.80 V	433.9	319.4	256.0	152.3	87.34	34.98	24.12	13.48	7.05
10.50 V	502.2	346.0	267.7	158.1	89.96	35.68	24.48	13.68	7.20
10.20 V	533.6	358.5	276.0	161.7	91.57	36.00	24.61	13.75	7.23
9.90 V	557.5	367.1	282.4	164.0	92.67	36.25	24.70	13.79	7.25
9.60 V	576.0	374.4	288.0	165.6	93.60	36.47	24.77	13.79	7.25

Constant Power Discharge Characteristics at 25°C/77°F for BP12-12

Final Voltage	Discharge Time: for Model BP26-12								
	5 min	10 min	15 min	30 min	1 hr	3 hr	5 hr	10 hr	20 hr
	Battery Output Power (W): for Model BP26-12								
10.80 V	940.0	692.0	554.6	330.0	189.23	75.79	52.25	29.20	15.26
10.50 V	1088.0	749.7	580.0	342.5	194.91	77.30	53.04	29.64	15.60
10.20 V	1156.0	776.7	598.0	350.3	198.41	78.00	53.33	29.79	15.67
9.90 V	1208.0	795.3	611.8	355.2	200.79	78.54	53.52	29.88	15.71
9.60 V	1248.0	811.2	624.0	358.8	202.80	79.01	53.68	29.88	15.71

Constant Power Discharge Characteristics at 25°C/77°F for BP26-12

B & B BATTERY

BP5-12 Battery Discharge Characteristics (25°C/77°F)

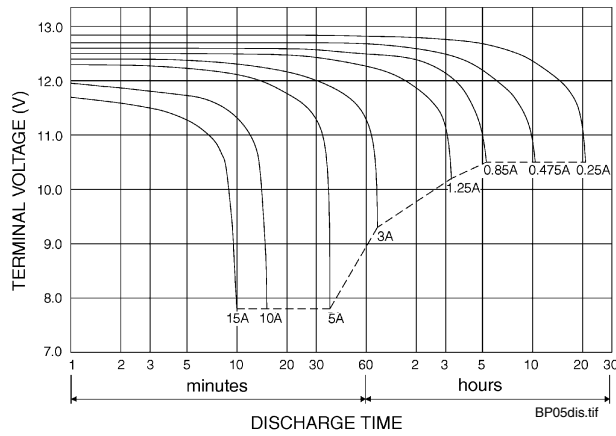

BP7-12 Battery Discharge Characteristics (25°C/77°F)

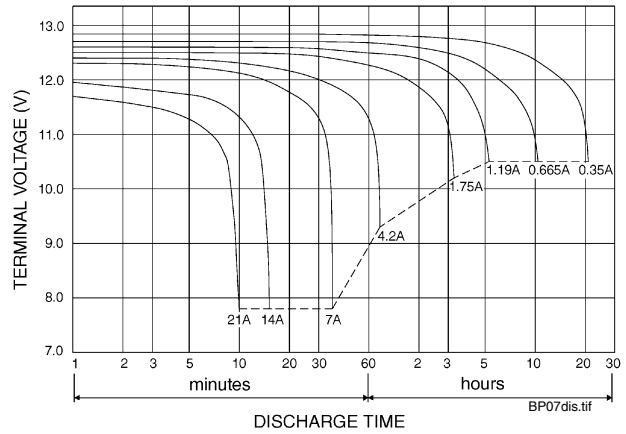

BP12-12 Battery Discharge Characteristics (25°C/77°F)

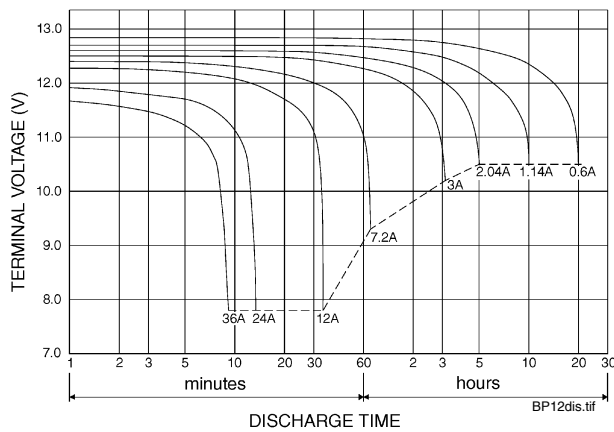

BP26-12 Battery Discharge Characteristics (25°C/77°F)

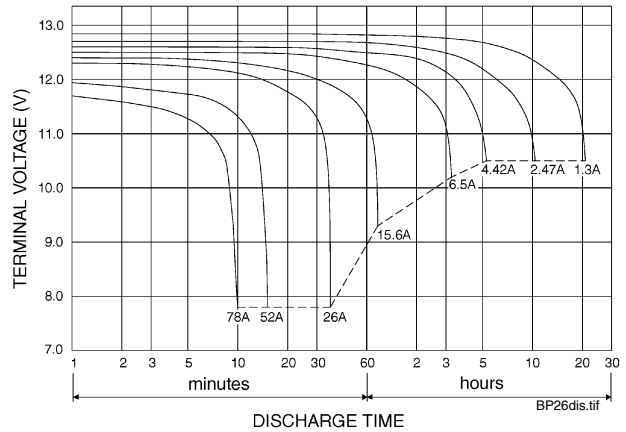

BP05-12



BP12-12



BP26-12



UPG BATTERY

UB1250 has the same specifications as previous Jolt SA1250; SA1272 to be replaced with UB1270 (specs/diagrams pending).

UB1250 (previously SA1250) Diagrams

UB1250/SA1250 discharge current vs. time

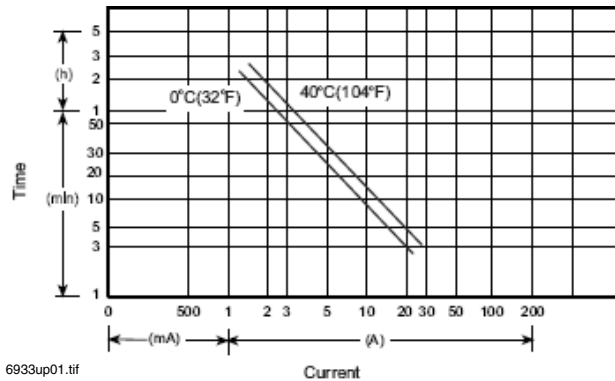

6933up01.tif

UB1250/SA1250 discharge characteristics (25°C/77°F)

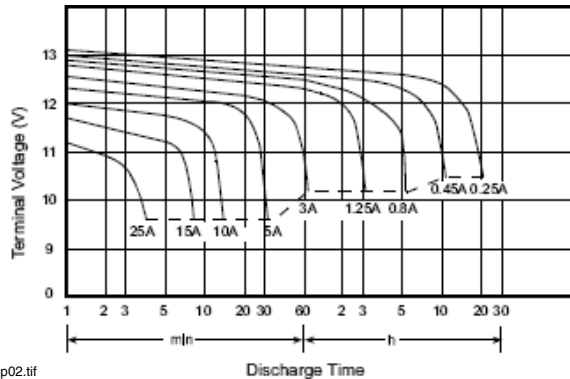

6933up02.tif

UB1250, SA1250 Specifications

- Nominal voltage: 12 V.
- Nominal capacity (20 hr): 5.0 AH.
- Dimensions: total height 107 mm (4.21"); container height 101 mm (3.98"); length 90 mm (3.54"); width 70 mm (2.76").
- Weight: approximately 1.83 kg (4.03 lbs).
- Container material: UL94HB ABS, UL94V-0 ABS.
- Internal resistance (25°C, 77°F): ~ 32 m.
- Discharge capacity under different temperatures:
 - 40°C: ~ 102%
 - 25°C: ~ 100%
 - 0°C: ~ 85%
- Capacity 25°C/77°F:
 - 20 hr @ 0.25 A: 5.0 AH.
 - 5 hr @ 0.8 A: 4.0 AH.
 - 1 hr @ 3.0 A: 3.0 AH.
 - 1 C @ 5.0 A: 2.5 AH.
- Charging voltage (25°C, 77°F):
 - Standby use: 13.65 V ± 0.15 V.
 - Cycle use: 14.7 V ± 0.3 V.
- Maximum discharge current: 60 A (5 sec).
- Maximum charging current: 1.5 A.
- Self-discharge residual capacity (25°C, 77°F):
 - After 3 months: ~ 90%.
 - After 6 months: ~ 82%.
 - After 12 months: ~ 70%.

SA1272 Diagrams

SA1272 discharge current vs. time

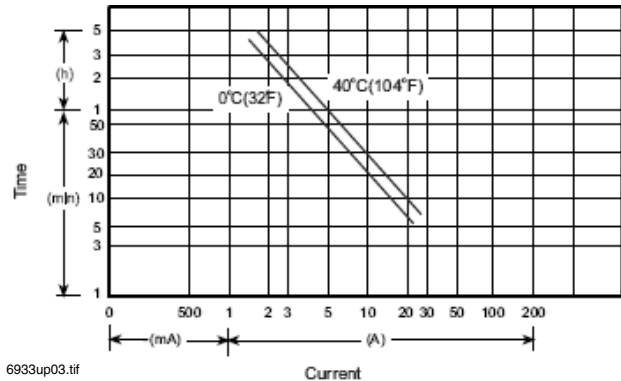

6933up03.tif

SA1272 discharge characteristics (25°C/77°F)

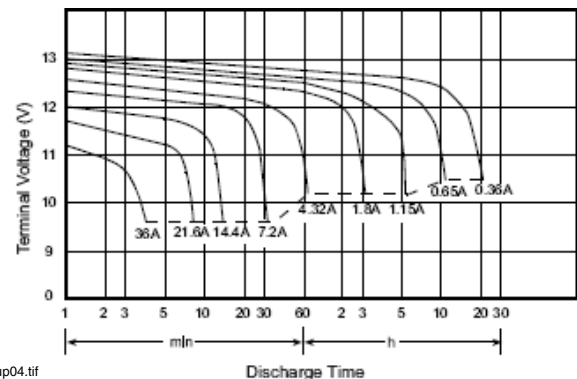

6933up04.tif

SA1272 Specifications

- Nominal voltage: 12 V.
- Nominal capacity (20 hr): 7.2 AH.
- Dimensions: total height 100 mm (3.94"); container height 94 mm (3.70"); length 151 mm (5.95"); width 65 mm (2.56").
- Weight: approximately 2.66 kg (5.85 lbs).
- Container material: UL94HB ABS, UL94V-0 ABS.
- Internal resistance (25°C, 77°F): ~ 22 m.
- Discharge capacity under different temperatures:
 - 40°C: ~ 102%
 - 25°C: ~ 100%
 - 0°C: ~ 85%
- Capacity 25°C/77°F:
 - 20 hr @ 0.36 A: 7.2 AH.
 - 5 hr @ 1.15 A: 5.76 AH.
 - 1 hr @ 4.32 A: 4.32 AH.
 - 1 C @ 7.2 A: 3.6 AH.
- Charging voltage (25°C, 77°F):
 - Standby use: 13.65 V ± 0.15 V.
 - Cycle use: 14.7 V ± 0.3 V.
- Maximum discharge current: 90 A (5 sec).
- Maximum charging current: 2.16 A.
- Self-discharge residual capacity (25°C, 77°F):
 - After 3 months: ~ 90%.
 - After 6 months: ~ 82%.
 - After 12 months: ~ 70%.

UPG BATTERY

Same specifications as previous Jolt models; packaging and part numbers are the only changes.

UB12120 (was SA12120) Diagrams

UB12120/SA12120 discharge current vs. time

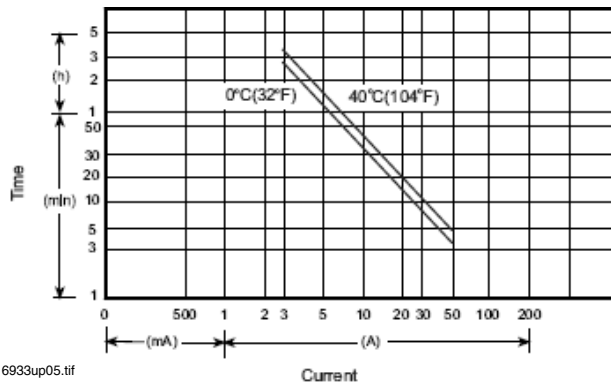

6933up05.tif

UB12120/SA12120 discharge characteristics (25°C/77°F)

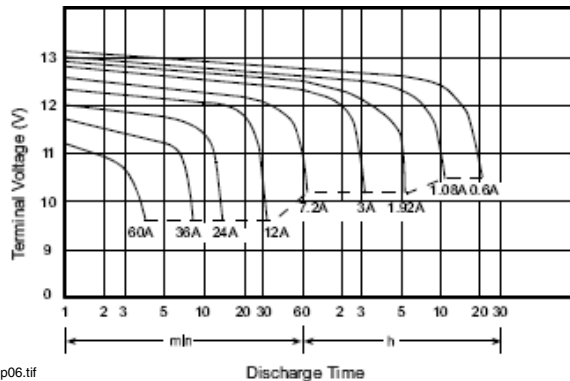

6933up06.tif

UB12120, SA12120 Specifications

- Nominal voltage: 12 V.
 - Nominal capacity (20 hr): 12.0 AH.
 - Dimensions: total height 100 mm (3.94"); container height 94 mm (3.70"); length 151 mm (5.95"); width 98 mm (3.86").
 - Weight: approximately 4.10 kg (9.04 lbs).
 - Container material: UL94HB ABS, UL94V-0 ABS.
 - Internal resistance (25°C, 77°F): ~ 14 m.
 - Discharge capacity under different temperatures:
 - 40°C: ~ 102%
 - 25°C: ~ 100%
 - 0°C: ~ 85%
 - Capacity 25°C/77°F:
 - 20 hr @ 0.6 A: 12.0 AH.
 - 5 hr @ 1.92 A: 9.6 AH.
 - 1 hr @ 7.2 A: 7.2 AH.
 - 1 C @ 12.0 A: 6.0 AH.
 - Charging voltage (25°C, 77°F):
 - Standby use: 13.65 V ± 0.15 V.
 - Cycle use: 14.7 V ± 0.3 V.
- Maximum discharge current: 120 A (5 sec).
 Maximum charging current: 3.6 A.
 Self-discharge residual capacity (25°C, 77°F):
 After 3 months: ~ 90%.
 After 6 months: ~ 82%.
 After 12 months: ~ 70%.

UB12180 (was SA12180) Diagrams

UB12180/SA12180 discharge current vs. time

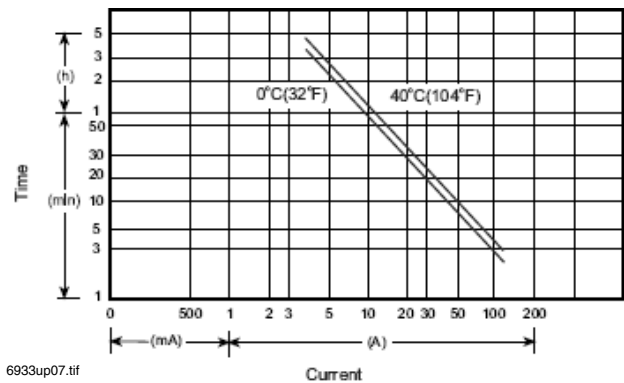

6933up07.tif

UB12180/SA12180 discharge characteristics (25°C/77°F)

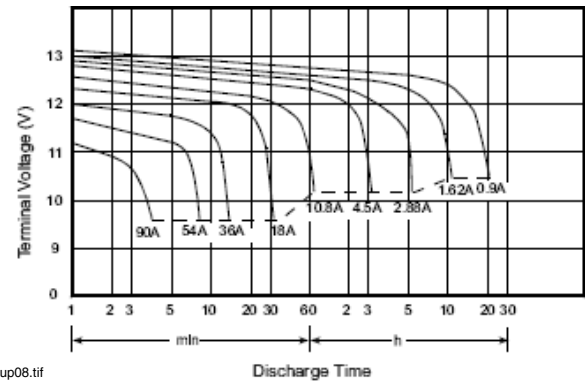

6933up08.tif

UB12180, SA12180 Specifications

- Nominal voltage: 12 V.
 - Nominal capacity (20 hr): 18.0 AH.
 - Dimensions: total height 167 mm (6.58"); container height 167 mm (6.58"); length 181 mm (7.13"); width 76 mm (2.99").
 - Weight: approximately 6.06 kg (13.36 lbs).
 - Container material: UL94HB ABS, UL94V-0 ABS.
 - Internal resistance (25°C, 77°F): ~ 13 m.
 - Discharge capacity under different temperatures:
 - 40°C: ~ 102%
 - 25°C: ~ 100%
 - 0°C: ~ 85%
 - Capacity 25°C/77°F:
 - 20 hr @ 0.9 A: 18.0 AH.
 - 5 hr @ 2.88 A: 14.4 AH.
 - 1 hr @ 10.8 A: 10.8 AH.
 - 1 C @ 18.0 A: 9.0 AH.
 - Charging voltage (25°C, 77°F):
 - Standby use: 13.65 V ± 0.15 V.
 - Cycle use: 14.7 V ± 0.3 V.
- Maximum discharge current: 300 A (5 sec).
 Maximum charging current: 5.4 A.
 Self-discharge residual capacity (25°C, 77°F):
 After 3 months: ~ 90%.
 After 6 months: ~ 82%.
 After 12 months: ~ 70%.

UPG BATTERY

Same specifications as previous Jolt models; packaging and part numbers are the only changes.

UB12260 (was SA12260) Diagrams

UB12260/SA12260 discharge current vs. time

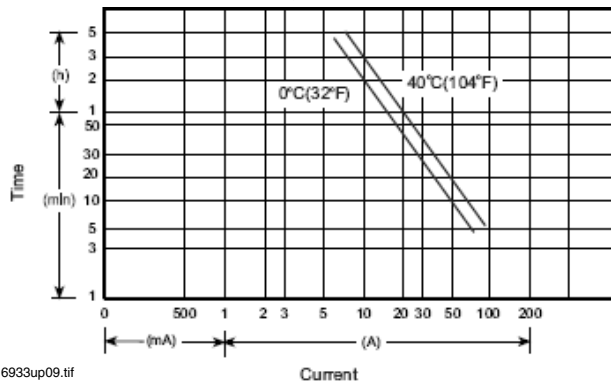

6933up09.tif

UB12260/SA12260 discharge characteristics (25°C/77°F)

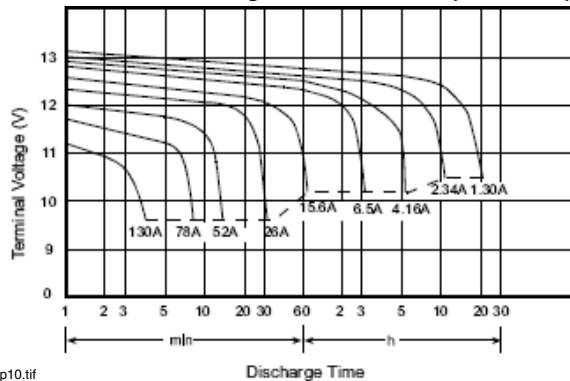

6933up10.tif

UB12260, SA12260 Specifications

- Nominal voltage: 12 V.
- Nominal capacity (20 hr): 26.0 AH.
- Dimensions: total height 125 mm (4.92"); container height 125 mm (4.92"); length 166 mm (6.54"); width 175 mm (6.89").
- Weight: approximately 8.80 kg (19.40 lbs).
- Container material: UL94HB ABS, UL94V-0 ABS.
- Internal resistance (25°C, 77°F): ~ 10 m.
- Discharge capacity under different temperatures:
 - 40°C: ~ 102%
 - 25°C: ~ 100%
 - 0°C: ~ 85%
- Capacity 25°C/77°F:
 - 20 hr @ 1.3 A: 26.0 AH.
 - 5 hr @ 4.16 A: 20.8 AH.
 - 1 hr @ 15.6 A: 15.6 AH.
 - 1 C @ 26.0 A: 13.0 AH.
- Charging voltage (25°C, 77°F):
 - Standby use: 13.65 V ± 0.15 V.
 - Cycle use: 14.7 V ± 0.3 V.
- Maximum discharge current: 300 A (5 sec).
- Maximum charging current: 7.8 A.
- Self-discharge residual capacity (25°C, 77°F):
 - After 3 months: ~ 90%.
 - After 6 months: ~ 82%.
 - After 12 months: ~ 70%.

UB12550 (was SA12550) Diagrams

UB12550/SA12550 discharge current vs. time

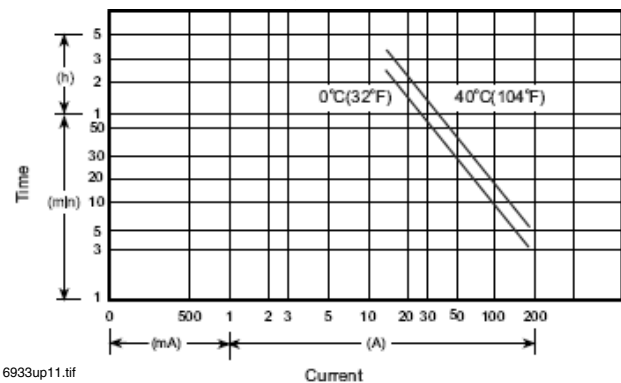

6933up11.tif

UB12550/SA12550 discharge characteristics (25°C/77°F)

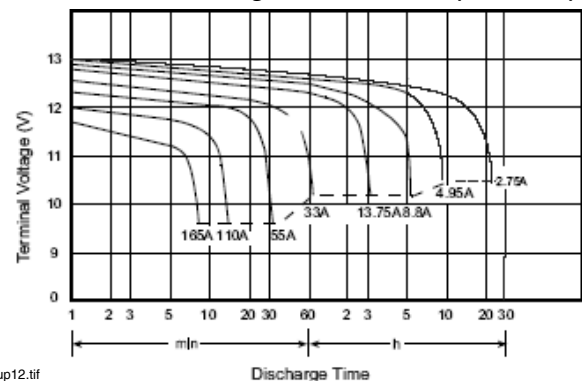

6933up12.tif

UB12550, SA12550 Specifications

- Nominal voltage: 12 V.
- Nominal capacity (20 hr): 55.0 AH.
- Dimensions: total height 234.5 mm (9.23"); container height 216.5 mm (8.52"); length 229 mm (9.02"); width 138 mm (5.43").
- Weight: approximately 19.0 kg (41.8 lbs).
- Container material: UL94HB ABS, UL94V-0 ABS.
- Internal resistance (25°C, 77°F): ~ 8 m.
- Discharge capacity under different temperatures:
 - 40°C: ~ 102%
 - 25°C: ~ 100%
 - 0°C: ~ 85%
- Capacity 25°C/77°F:
 - 20 hr @ 2.75 A: 55.0 AH.
 - 5 hr @ 8.8 A: 44.0 AH.
 - 1 hr @ 33.0 A: 33.0 AH.
 - 1 C @ 55.0 A: 27.5 AH.
- Charging voltage (25°C, 77°F):
 - Standby use: 13.65 V ± 0.15 V.
 - Cycle use: 14.7 V ± 0.3 V.
- Maximum discharge current: 600 A (5 sec).
- Maximum charging current: 16.5 A.
- Self-discharge residual capacity (25°C, 77°F):
 - After 3 months: ~ 90%.
 - After 6 months: ~ 82%.
 - After 12 months: ~ 70%.

UPG BATTERY

Same specifications as previous Jolt models; packaging and part numbers are the only changes.

UB121000 (XSA121000A) Diagrams

UB121000/XSA121000A discharge current vs. time

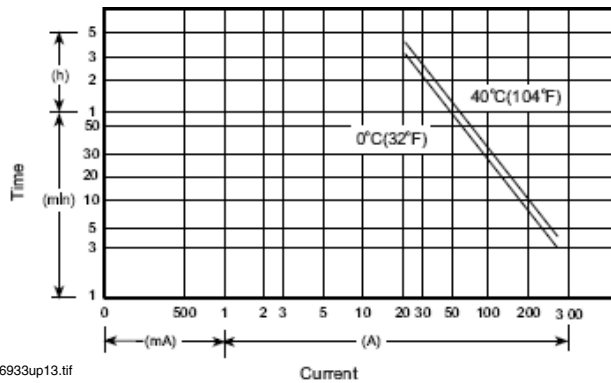

UB121000/XSA121000A discharge characteristics (25°C/77°F)

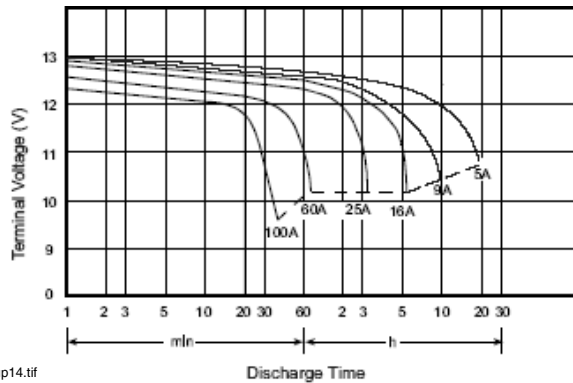

UB121000 (XSA121000A) Diagrams

- Nominal voltage: 12 V.
- Nominal capacity (20 hr): 100.0 AH.
- Dimensions: total height 221 mm (8.70"); container height 214 mm (8.43"); length 329 mm (12.95"); width 172 mm (6.77").
- Weight: approximately 34.00 kg (74.8 lbs).
- Container material: UL94HB ABS, UL94V-0 ABS.
- Internal resistance (25°C, 77°F): ~ 6.5 m.
- Discharge capacity under different temperatures:
 - 40°C: ~ 102%
 - 25°C: ~ 100%
 - 0°C: ~ 85%
- Capacity 25°C/77°F:
 - 20 hr @ 5.0 A: 100.0 AH.
 - 5 hr @ 16.0 A: 80.0 AH.
 - 1 hr @ 60.0 A: 60.0 AH.
 - 1 C @ 100.0 A: 50.0 AH.
- Charging voltage (25°C, 77°F):
 - Standby use: 13.65 V ± 0.15 V.
 - Cycle use: 14.7 V ± 0.3 V.
- Maximum discharge current: 600 A (5 sec).
- Maximum charging current: 30 A.
- Self-discharge residual capacity (25°C, 77°F):
 - After 3 months: ~ 90%.
 - After 6 months: ~ 82%.
 - After 12 months: ~ 70%.

UPG Summary Diagrams

Summary discharge characteristics

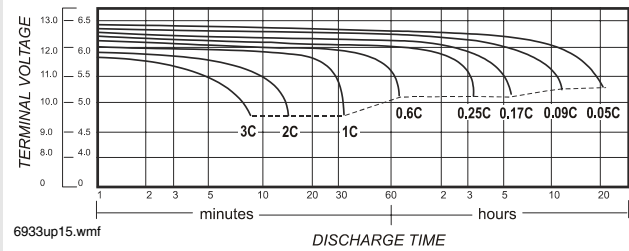

Summary discharge current vs. time curve (25°C/77°F)

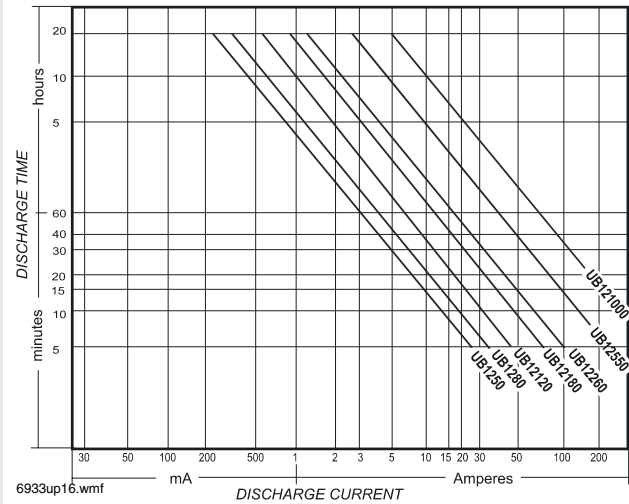

UPG BATTERY

Same specifications as previous Jolt models;
packaging and part numbers are the only changes.

Charging Procedure: UPG Battery

Application	Charging method	Charging voltage at 25°C (V/cell)	Temperature compensation coefficient of charging voltage (mV/°C/cell)	Maximum charging current (CA)	Charging time 0.1 CA, 25°C (h)		Temp (°C)
					100% discharge	50% discharge	
For standby power source	Constant voltage and constant current charging (with current restriction)	2.25 ~ 2.30	- 3.3 (-1.8 mV/°F/cell)	0.3	T ³ 24	T ³ 20	0 – 40°C (32 – 104°F)
For cycle service		2.40 ~ 2.50	- 5 (-2.8 mV/°F/cell)	0.3	16 < T < 24	10 < T < 24	

Temperature compensation of charging voltage is not needed when using the batteries within 5°C to 35°C range.

NOTIFIER® is a registered trademark of Honeywell International Inc.
Batteries display trademarks of the manufacturer.
©2009 by Honeywell International Inc. All rights reserved. Unauthorized use
of this document is strictly prohibited.



This document is not intended to be used for installation purposes.
We try to keep our product information up-to-date and accurate.
We cannot cover all specific applications or anticipate all requirements.
All specifications are subject to change without notice.



Universal Digital Alarm Communicator Transmitter



Annunciator Control Systems

General

The Universal Digital Alarm Communicator Transmitter (UDACT) is designed for use on the Notifier NFS-320, NFS2-640, NFS2-3030, NFS-640 and NFS-3030 Fire Alarm Control Panels and on the NCA-2 and NCA Network Control Annunciator. When used in conjunction with the NCA-2 network control annunciators the UDACT can report the status of all control panels on NOTI•FIRE•NET™. The UDACT transmits system status to UL listed Central Station Receivers via the public switched telephone network.

NOTE: The UDACT can also be used with legacy panels. Please refer to the UDACT manual for more information.

The UDACT is compact in size and may be mounted externally in a separate cabinet. EIA-485 annunciator communications bus and regulated 24-volt connections are required.

The UDACT is capable of transmitting the status of software zones (Alarm and Trouble), System Trouble, Panel Off-Normal, Supervisory, Bell Trouble, Low Battery, and AC Fail. The UDACT is capable of transmitting all of the zone and point status associated with each panel.

When the UDACT is used with the NFS-3030, NFS2-3030, and NCA-2 it is capable of reporting up to 2,040 points. Reporting may be in the form of points or zones (refer to the UDACT manual for specific reporting parameters). The first 568 points transmitted may be programmed for a variety of types, including fire, waterflow, supervisory, etc. Remaining points transmitted are for fire alarm only.

NOTE: Descriptions regarding point capacity, listed above, are for receivers which receive in Ademco Contact ID format. See chart on page 2 for compatible receivers.

Features

- Maximum of 14 point trouble messages transmitted per hour.
- Dual phone lines.
- Dual telephone line voltage detect.
- Surface Mount Technology.
- Compact in size: 6.75" x 4.25" (17.145 x 10.795 cm).
- Built-in programmer.
- Built-in 4-character red 7-segment LED display.
- Manual Test Report function.
- Manual Transmission Clear function.
- Mounts in a separate enclosure (ABS-8RB or UBS-1).
- Communicates vital system status including:
 - Independent zone fire alarm.
 - Independent zone non-fire alarm.
 - Independent zone trouble.
 - Independent zone supervisory.
 - AC (mains) Power Loss (programmable).
 - Low Battery and Earth Fault.
 - System Off-Normal.
 - 12 or 24 hour test signal.
 - Abnormal Test Signal per new UL requirements.
 - EIA-485 Communication Bus Failure.

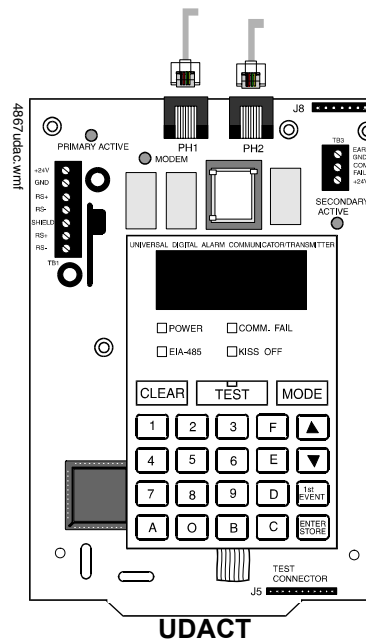

- Annunciation of UDACT Troubles including: loss of phone lines, communication failure with either Central Station, total communications failure.
- Troubleshoot Mode converts keypad to DTMF touchpad.
- Individual LEDs for: Power, EIA-485 Loss, Manual Test, Kissoff, Comm Fail, Primary Line Seize, Secondary Line Seize and Modem Communications.
- Open Collector relay driver for Total Communications Failure or UDACT trouble.
- Real-time clock.
- Extensive transient protection.
- Simple EIA-485 interface to host panel.

Agency Listings and Approvals

In some cases, certain modules may not be listed by certain approval agencies, or listing may be in process. Consult factory for latest listing status.

- UL Listed: S635
- ULC Listed: CS100 Vol. VII
- MEA: 328-94-E; 317-01-E3
- CSFM: 7300-0028:174; 7165-0028:214; 7165-0028:224; 7170-0228:216; 7170-0028:223; 7165-0028:243, 7170-0028:244
- INDUSTRY CANADA: 2132 6030 A
- FCC: 1W6-USA-20723-AL-E
- FM Approved

Communication Formats

- 3+1 Standard
- 4+1 Standard
- 4+2 Standard
- 4+1 and 4+2 Ademco Express
- Ademco Contact ID

NOTE: Ademco Contact ID must be used for independent zone reporting.

Type Mode Feature

Ademco Contact ID format only) Use Type Mode to identify reports to Central Station as:

- Fire Alarm
- Supervisory
- Pull Station
- Heat Detector
- Waterflow
- Duct Detector
- Flame Sensor
- Smoke Zone
- Burglary
- 24 hour Non-Burglary
- High Temperature
- Low Temperature
- Low Water Pressure
- Low Water Level
- Pump Failure

Electrical Specifications

Standby current: 40 mA.

Current while communicating: 75 mA.

Maximum current while communicating and with collector output activated: 100 mA.

Voltage: Regulated 24 volts. Range: 21.2 to 28.2 volts.

Ordering Information

UDACT: Universal Digital Alarm Communicator Transmitter. Includes operating and programming instructions, and mounting hardware.

MCBL-7: DACT phone cord, 7 ft (2.13 m) long (two required).

ABS-8RB: Metal enclosure for externally mounting UDACT up to 6,000 ft./1828.8 m from host FACP. 9.94" H x 4.63" W x 2.50" D (cm: 25.248 H x 11.760 W x 6.350 D).

UBS-1: Metal enclosure. Includes viewing window and optional relay mounting capability.

R-10E: SPDT Form-C relay. Contacts rated for 10 A @ 115 VAC. Connects to open collector relay driver.

R-20E: DPDT Two Form-C relays. Contacts rated for 10A @ 115 VAC. Connects to open collector relay driver.

FBD-1: Ferrite bead kit. Use for remote mounting only.

ROM1-UDACT: EPROM upgrade kit.

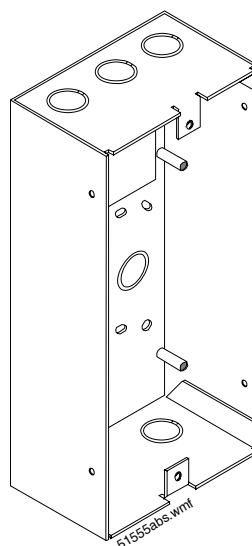

ABS-8RB
for remote mounting
[9.94"(25.2476cm)H x
4.63"(11.7602cm)W x
2.5"(6.35cm)D]

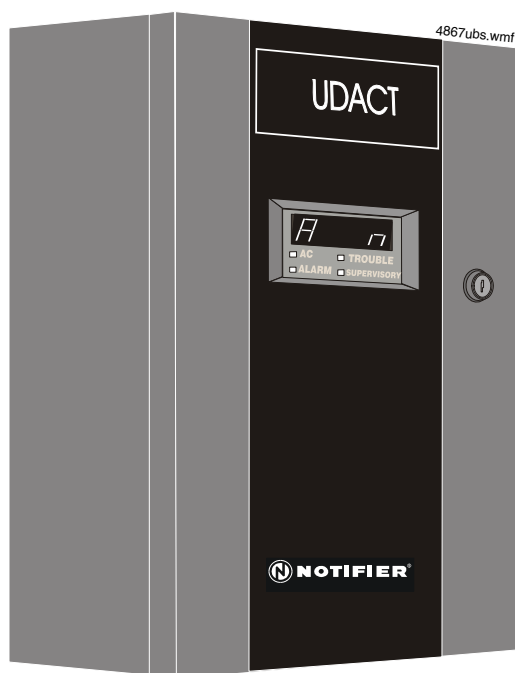

UDACT
shown in UBS-1

	Format # (Addresses 16 & 42)	Ademco 685 (1)	Silent Knight 9000	ITI CS-4000 (3)	FBI CP220FB	Osborne Hoffman Models 1 & 2	Radionics 6000/6500 (5)	Sescoa 3000R (7)	SurGuard MLR-2 (9)
0	4 + 1 Ademco Express	X			X				X
1	4 + 2 Ademco Express	X			X	X(8)			X
2	3 + 1 /Standard/1800/2300	X	X (2)	X	X(4)	X	X(5,6)	X	X
3	(NOT USED)								
4	3 + 1 /Standard/1900/1400	X	X (2)		X(4)	X		X	X
5	(NOT USED)								
6	4 + 1 /Standard/1800/2300	X	X (2)	X	X(4)	X	X(5)	X	X
7	(NOT USED)								
8	4 + 1 /Standard/1900/1400	X	X (2)		X(4)	X		X	X
9	(NOT USED)								
A	4 + 2 /Standard/1900/2300	X	X (2)	X	X(4)	X	X(5)	X	X
B	(NOT USED)								
C	4 + 2 /Standard/1900/1400	X	X (2)		X(4)	X		X	X
D	(NOT USED)								
E	Ademco Contact ID	X			X	X			X
F	(NOT USED)								

- 1.) With 685-8 Line Card with Rev. 4.4d software.
- 2.) With 9002 Line Card Rev. 9035 software or 9032 Line Card with 9326A software.
- 3.) Rev. 4.0 software.
- 4.) FBI CP220FB Rec-11 Line Card with Rev. 2.6 software and a memory card with Rev. 3.8 software.
- 5.) Model 6500 with Rev. 600 software.
- 6.) Model 6000 with Rev. 204 software.
- 7.) With Rev. B control card at Rev. 1.4 software and Rev. C line card at Rev. 1.5 software.
- 8.) Model 2 only.
- 9.) Version 1.62 software.

NOTI•FIRE•NET™ is a trademark and Notifier® is a registered trademark of Honeywell International Inc.
©2006 by Honeywell International Inc. All rights reserved. Unauthorized use of this document is strictly prohibited.



This document is not intended to be used for installation purposes.
We try to keep our product information up-to-date and accurate.
We cannot cover all specific applications or anticipate all requirements.
All specifications are subject to change without notice.



➤ ONYXWorks® NFN

Gateway-3



Network Systems

General

The NOTI•FIRE•NET™ Gateway is an intelligent gateway interface for the ONYXWorks® fire monitoring workstation. This gateway facilitates complete monitoring and control of a NOTI•FIRE•NET™ network. In addition, it supports full panel programming and network diagnostics.

The embedded gateway is a standalone version and is equipped with IP capability thus enabling ONYX® Series users to monitor multiple sites over an Ethernet network without the need for remote workstations.

Features

- Enables ONYX® Series workstation to monitor alarm, pre-alarm, trouble, disabled events, etc. for Notifier fire alarm control panels.
- Compatible with standard and high speed NOTI•FIRE•NET™ network.
- Adds acknowledge, silence, reset, enable/disable, and activate/deactivate control capability to the workstation.
- Supports fire alarm control panel programming upload/downloads and modifications.
- Embedded gateway allows remote IP connections and increases scalability of network.
- Supervised IP connections for remote workstations and gateways.
- Multiple workstations and FirstVisions can access the gateway at the same time.
- Gateway redundancy for network survivability.

Compatibility

The NOTI•FIRE•NET™ Gateway is compatible with ONYXWorks® and ONYX FirstVision and interfaces to NOTI•FIRE•NET™ version 5.0 and higher, as well as a high speed NOTI•FIRE•NET™ network for the following panels and devices:

- ONYX Series
- AM2020/AFP1010 (version 5.0 SIB-NET)
- AFP-200 (version 5.0 NAM)
- AFP-300/AFP-400 (version 5.0 NAM)
- BACnet Gateway
- NCA-2/NCA Network Control Annunciator
- NOTI•FIRE•NET™ Web Server

Specifications

- Power input: 24 VDC
- Input current: 450 mA @ 24 VDC with or without NCM.
- Operating temperature: 0°C to 49°C (32°F to 120°F).
- Direct connection to NFS2-640, NFS640, NFS-320, NFS2-3030, and NFS-3030 fire alarm control panels. NCM required for connection to NOTI•FIRE•NET™ and high speed NFN. (see data sheet DN-6861).

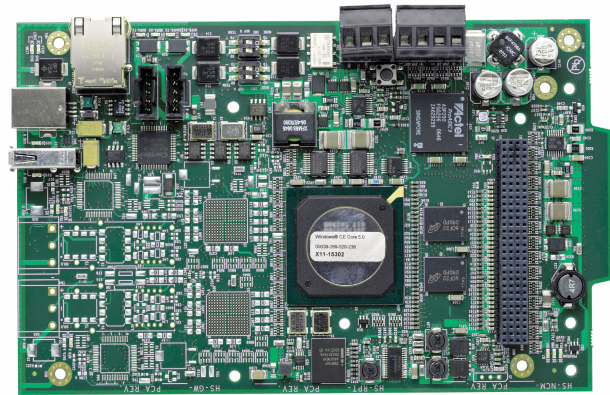

➤ NFN-GW-EM-3

Standards and Codes

The NOTI•FIRE•NET™ Gateway complies with the following UL/ULC Standards and NFPA 72 Fire Alarm Systems requirements:

- UL 864
- UL 1076
- UL 2017
- ULC S559-04
- ULC S527-99

Listings and Approvals

These listings and approvals apply to the modules specified in this document. In some cases, certain modules or applications may not be listed by certain approval agencies, or listing may be in process. Consult factory for latest listing status.

- **UL / ULC:** S5526; S5697
- **CSFM:** 7300-1525:103
- **MEA:** 286-07-E

Ordering Information

NFN-GW-EM-3: NOTI•FIRE•NET™ Gateway, embedded. Includes PC board, NUP to NUP cable (75556), USB Cable (75665) and NFN Configuration tool.

Additional EMBEDDED VERSION Gateway required components:

- NCM for connection to NOTI•FIRE•NET™.
- IBM®-compatible PC with Windows® XP.
- Standard Ethernet network cable with RJ45 to RJ45 connectors.
- ONYXWorks Workstation V3.11 or First Vision 1.7 or above.
- NFN Network Version 5.0 or above.
- Verifire Tools Version 5.7.

NFN-GW-EM-3

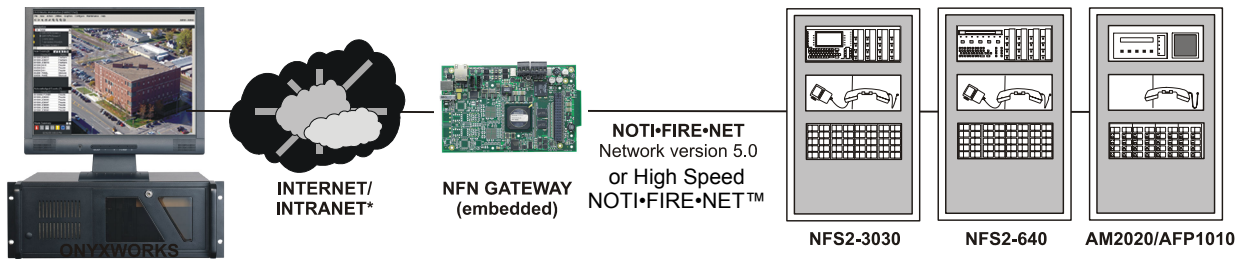

* A UL Listed ethernet (TCP/IP) switch is required between a shared-IP network and the ONYXWORKS equipment. Contemporary Control Systems, Inc. (www.ctrlink.com) has several UL864 recognized switching hubs.

Firefighters' Display

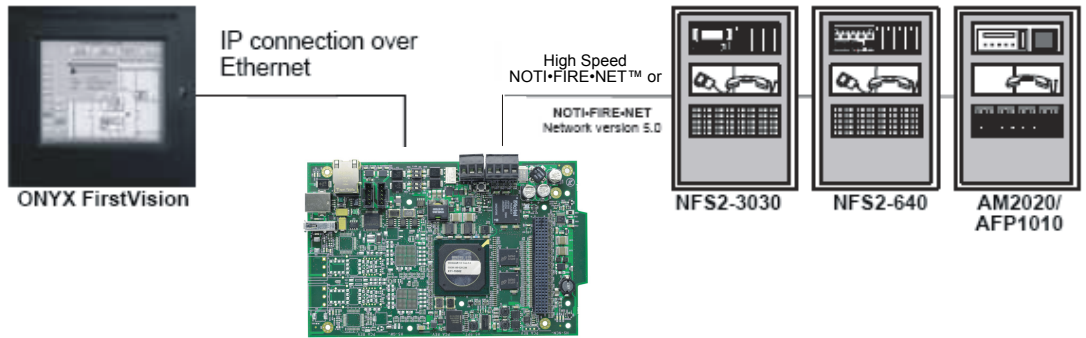

NION®, NOTIFIER®, ONYX® and ONYXWorks® are registered trademarks and NOTI•FIRE•NET™, NOTIFY-IP™, and ONYX FirstVision™ are trademarks of Honeywell International Inc. Windows® is a registered trademark of Microsoft Corporation.
 ©2009 by Honeywell International Inc. All rights reserved. Unauthorized use of this document is strictly prohibited.



This document is not intended to be used for installation purposes.
 We try to keep our product information up-to-date and accurate.
 We cannot cover all specific applications or anticipate all requirements.
 All specifications are subject to change without notice.



➤ FSP-851, FSP-851T, & FSP-851R

Intelligent Plug-In Photoelectric



Intelligent/Addressable Devices

General

Notifier 851 Series intelligent plug-in smoke detectors with integral communication provide features that surpass conventional detectors. Detector sensitivity can be programmed in the control panel software. Sensitivity is continuously monitored and reported to the panel. Point ID capability allows each detector's address to be set with decade address switches, providing exact detector location for selective maintenance when chamber contamination reaches an unacceptable level. The FSP-851 photoelectric detector's unique optical sensing chamber is engineered to sense smoke produced by a wide range of combustion sources. Dual electronic thermistors add 135°F (57°C) fixed-temperature thermal sensing on the FSP-851T. The FSP-851R is a remote test capable detector for use with DNR(W) duct detector housings. FSP-851 series detectors are compatible with all ONYX series Notifier intelligent Fire Alarm Control Panels (FACP).

FlashScan® (U.S. Patent 5,539,389) is a communication protocol developed by Notifier that greatly increases the speed of communication between analog intelligent devices. Intelligent devices communicate in a grouped fashion. If one of the devices in the group has new information, the panel's CPU stops the group poll and concentrates on single points. The net effect is response speed greater than five times that of earlier designs.

Features

- Sleek, low-profile design.
- Addressable-analog communication.
- Stable communication technique with noise immunity.
- Low standby current.
- Two-wire SLC connection.
- FlashScan (NFS-320, NFS-640, NFS2-640, NFS-3030, NFS2-3030) and classic CLIP systems (AFP-100, AFP-200, AFP-300, AFP-400, NFS-640, AM2020/AFP1010, NFS-3030) compatible.
- Rotary, decimal addressing (1-99 on CLIP systems, 1-159 on FlashScan systems).
- Optional remote, single-gang LED accessory.
- Dual LED design provides 360° viewing angle.
- Visible bi-color LEDs blink green every time the detector is addressed, and illuminate steady red on alarm (*FlashScan systems only*).
- Remote test feature from the panel.
- Walk test with address display (an address on 121 will blink the detector LED: 12-[pause]-1 (*FlashScan systems only*)).
- Built-in functional test switch activated by external magnet.
- Built-in tamper-resistant feature.
- Sealed against back pressure.
- Constructed of off-white Bayblend®, designed to commercial standards, and offers an attractive appearance.
- 94-5V plastic flammability rating.
- SEMS screws for wiring of the separate base.
- Optional relay, isolator, and sounder bases.



FSP-851 with B710LP base



FSP-851T with B710LP base

Specifications

Size: 2.1" (5.3cm) high x 4.1" (10.4cm) diameter installed in B501 base, 6.1" (15.5cm) diameter installed in B710LPbase.

Shipping Weight: 5.2oz. (147g).

Operating Temperature: FSP-851, 0°C to 49°C (32°F to 120°F); FSP-851T, 0°C to 38°C (32°F to 100°F). Low temperature signal for FSP-851T at 45°F +/- 10°F (7.22°C +/- 5.54°C). FSP-851R installed in a DNR(W), -20°C to 70°C (-4°F to 158°F).

UL/ULC Listed Velocity Range: 0-4000 ft/min. (1219.2 m/min.), suitable for installation in ducts.

Relative Humidity: 10%-93% noncondensing.

Thermal Ratings: Fixed-temperature setpoint 135°F (57°C).

DETECTOR SPACING AND APPLICATIONS

Notifier recommends spacing detectors in compliance with NFPA 72. In low airflow applications with smooth ceiling, space detectors 30 feet (9.144m) for ceiling heights 10 feet (3.148m) and higher. For specific information regarding detector spacing, placement, and special applications refer to NFPA 72. *System Smoke Detector Application Guide*, document A05-1003, is available at systemsensor.com

ELECTRICAL SPECIFICATIONS

Voltage Range: 15-32 volts DC peak.

Standby Current (max. avg.): 300µA @ 24VDC (one communication every five seconds with LED enabled).

LED Current (max.): 6.5mA @ 24VDC ('ON').

BASES AVAILABLE

NOTE: "A" suffix indicates ULC Listed model.

B710LP(A): 6.1" (15.5cm) diameter.

B501(A): 4.1" (10.4cm) diameter.

B200SR(A): Intelligent sounder base, configurable for temp-3 or steady sound.

B224RB(A) Relay Base: *Screw Terminals*, up to 14AWG (2.0mm²); *Relay Type*, Form-C; *Rating*, 2.0A @ 30VDC resistive, 0.3A @ 110VDC inductive, 1.0A @ 30VDC inductive; *Dimensions*, 6.2" (15.748cm) x 1.2" (3.048cm) x 1.2" (3.048cm).

B224BI(A) Isolator Base: *Dimensions*, 6.2" (15.748cm) x 1.2" (3.048cm) x 1.2" (3.048cm); *Maximum*, 25 devices between isolator bases.

Installation

FSP-851 plug-in detectors use a separate base to simplify installation, service, and maintenance. A special tool allows maintenance personnel to plug in and remove detectors without using a ladder.

Mount base on an electrical backbox which is at least 1.5" (3.81cm) deep. Suitable mounting base boxes include:

- 4.0" (10.16cm) square box.
- 3.5" (8.89cm) or 4.0" (10.16cm) octagonal box.
- Single-gang box (except relay or isolator base).
- With B200SR base, use an appropriate junction box.
- With B224RB or B224BI base, use a 3.5" (8.89cm) octagonal box, or a 4.0" (10.16cm) octagonal or square box.

NOTE: 1) Because of inherent supervision provided by the SLC loop, end-of-line resistors are not required. Wiring "T-taps" or branches are permitted for style 4 (Class "B") wiring. 2) When using relay or sounder bases, consult data sheet DN-2243 (ISO-X) for device limitations between isolator modules and isolator bases.

Agency Listings and Approvals

These listings and approvals apply to the modules specified in this document. In some cases, certain modules or applications may not be listed by certain approval agencies, or listing may be in process. Consult factory for latest listing status.

- **UL Listed:** S1115
- **ULC Listed:** S1115 (FSP-851A, FSP-851TA)
- **MEA Listed:** 225-02-E
- **FM Approved**
- **CSFM:** 7272-0028:206
- **Maryland State Fire Marshal:** Permit # 2122
- **BSMI:** CI313066760036
- **CCCF:** Certif. # 2004081801000017 (FSP-851T)
Certif. # 2004081801000016 (FSP-851)
- **Lloyd's Register:** 03/60011

Product Line Information

NOTE: "A" or "CDN" suffix indicates ULC listed model.

FSP-851: Low-profile intelligent photoelectric sensor. Must be mounted to one of the bases listed below.

FSP-851A: Same as FSP-851 but with ULC listing.

FSP-851T: Same as FSP-851 but includes a built-in 135°F (57°C) fixed-temperature thermal device.

FSP-851TA: Same as FSP-851T but with ULC listing.

FSP-851R: Low-profile intelligent photoelectric sensor, remote test capable. For use with DNRW.

FSP-851RA: Same as FSP-851R but with ULC listing.

BASES

B710LP: Standard U.S. low-profile base.

B710LPBP: Standard U.S. low-profile base, pkg. of 10.

B710LPA: Standard U.S. low-profile base, ULC listing.

B501BP: Standard European flangeless base, pkg. of 10.

B501A: Standard European flangeless base, ULC listing.

B200SR(A): Intelligent sounder base, configurable for temp-3 or steady sound.

B224RB(A): Intelligent relay base.

B224BI(A): Intelligent isolator base. Isolates SLC from loop shorts.

ACCESSORIES

F110: Retrofit replacement flange for older style bases. Converts older high profile base for use with FlashScan detectors.

RA100Z(A): Remote LED annunciator. 3-32VDC. Fits U.S. single-gang electrical box. Supported by B710LP(A) and B501(A) bases only.

SMK400E: Surface mounting kit provides for entry of surface wiring conduit. For use with B501(A) base only.

RMK400: Recessed mounting kit. For use with B501(A) base only.

SMB600: Surface mounting kit for use with B710LP(A).

BCK-200B: Black detector covers, box of 10. For use with FSP-851 only.

WCK-200B: White detector covers, box of 10. For use with FSP-851 only.

M02-04-00: Test magnet.

M02-09-00: Test magnet with telescope stick.

XR2B: Detector removal tool. Allows installation and/or removal of FlashScan Series detector heads from base in high ceiling installations.

T55-127-010: Detector removal tool without pole.

XP-4: Extension pole for XR2B. Comes in three 5-ft. sections.

Notifier® and FlashScan® are registered trademarks of Honeywell International Inc. Bayblend® is a registered trademark of Bayer Corporation. ©2010 by Honeywell International Inc. All rights reserved. Unauthorized use of this document is strictly prohibited.



This document is not intended to be used for installation purposes. We try to keep our product information up-to-date and accurate. We cannot cover all specific applications or anticipate all requirements. All specifications are subject to change without notice.



Made in the U.S.A.

Intelligent Bases

B224BI(A), B224RB(A), B501(A), B501BH(A), B501BH-2(A), B501BHT(A), B501BHT-2(A), B710LP(A), Mounting Kits, and Accessories



Intelligent Addressable Devices

General

Intelligent FlashScan® and CLIP mounting bases and kits provide a variety of ways to install NOTIFIER detectors in any application. Intelligent detectors can be mounted in either flanged or flangeless bases depending on junction box selection (see *Junction Box Selection Guide*). Across this product line, detectors plug in easily to the base with SEMS screws; and models employ various 12 to 22 AWG wire ranges.

Relay, isolator, and sounder bases can be used to meet local code requirements. Relay bases provide one Form-C contact relay for control of auxiliary functions such as door closure and elevator recall. Isolator bases allow loops to continue to operate under fault conditions and automatically restore when the fault is removed. Sounder bases are available in temporal and non-temporal pattern versions depending on whether the signal is to be used for evacuation purposes.

The **RMK400 recessed mounting kit** provides the most aesthetically pleasing installation. Surface mounting boxes are available when flush mounting isn't possible.

Specifications

Diameter: For B501: 4.1" (104 mm). For B224BI, B224RB, B710LP: 6.1" (155 mm). For B501BH, B501BH-2, B501BHT, B501BHT-2: 6.0" (152 mm).

Wire gauge: for B224BI, B224RB: 14 to 24 AWG. For B710LP, B501, B501BH, B501BH-2, B501BHT, B501BHT-2: 12 to 18 AWG.

Temperature range: For B224BI, B224RB, B501BH, B501BH-2, B501BHT, B501BHT-2: 32°F to 120°F (0°C to 49°C). For B501 and B710LP, 32°F to 150°F (0°C to 66°C).

Humidity range: 10% to 93% RH, non-condensing.

System temperature and humidity ranges: This system meets NFPA requirements for operation at 0°C to 49°C (32°F to 120°F); and at a relative humidity (noncondensing) of 85% at 30°C (86°F) per NFPA, and 93% ± 2% at 32°C ± 2°C (89.6°F ± 1.1°F) per ULC. However, the useful life of the system's standby batteries and the electronic components may be adversely affected by extreme temperature ranges and humidity. Therefore, it is recommended that this system and all peripherals be installed in an environment with a nominal room temperature of 15°C to 27°C (60°F to 80°F).

Electrical Ratings

FOR B224RB, B224BI:

Operating voltage: 15 to 32 VDC (powered by SLC).

Standby ratings: <500 µA maximum @ 24 VDC.

Set time (B224RB only): short delay 55 to 90 msec; long delay 6 to 9 seconds.

Reset time (B224RB only): 20 msec maximum.

Relay characteristics (B224RB only): two-coil latching relay; one Form-C contact; ratings (UL/CSA): 0.9 A @ 125 VAC, 0.9 A @ 110 VDC, and 3.0 A @ 30 VDC.

FOR B501BH, B501BH-2, B501BHT, B501BHT-2:

External supply voltage: 17 to 32 VDC.

Standby current: 1.0 mA maximum.

Alarm current: 15 mA maximum.



Flangeless Mounting Base



Relay Base



Flanged Mounting Base



Recessed Mounting



Standard Sounder Base



Flangeless Surface Mounting

Maximum ripple voltage: 10% of supply voltage.

Startup capacitance: 200 µF.

Set time: for B501BH and B501BHT, 6 to 15 seconds. For B501BH-2 and B501BHT-2, 0.75 to 5.7 seconds.

Sound output: greater than 90 dBA measured in anechoic room at 10 feet (3.048 m), 24 volts. 85 dBA minimum in UL reverberant room.

Recessed Mounting Kit

The RMK400 can be used with drywall or suspended ceilings. The aesthetically pleasing design can be used with standard junction boxes — suitable for use with 4.0" (10.16 cm) octagonal, 50 mm, and 60 mm junction boxes connected to flexible conduit. Note that junction boxes are not included in the kit. As an application example, with the B501 base, the RMK400 provides a simple installation solution in applications that demand a lower-profile smoke detector.

Agency Listings and Approvals

The listings and approvals below apply to intelligent bases as noted. In some cases, certain modules or applications may not be listed by certain approval agencies, or listing may be in process. Consult factory for latest listing status.

Listing information to be provided in upcoming edits. Consult panel manuals for lists of compatible UL-Listed devices. All bases have been previously listed for use with various panels.

Product Line Information

INTELLIGENT BASES

B501: Flangeless mounting base.

B501A: Flangeless mounting base, ULC Listed.

B710LP: Flanged mounting base.
B710LPA: Flanged mounting base, ULC UL Listed.
B501BH: Standard sounder base.
B501BHA: Standard sounder base, ULC Listed.
B501BHT: Temporal tone sounder base.
B501BH-2: Standard sounder base, UL 864 9th edition compliant.
B501BH-2A: Standard sounder base, UL 864 9th edition compliant, ULC Listed.
B501BHT-2: Temporal tone sounder base, UL 864 9th edition compliant.
B501BHT-2A: Temporal tone sounder base, UL 864 9th edition compliant, ULC Listed.
B224RB: Relay base.
B224RBA: Relay base, ULC Listed.

B224BI: Isolator base.
B224BIA: Isolator base, ULC Listed.
MOUNTING KITS AND ACCESSORIES
RMK400: Recessed mounting kit.
SMK400: Surface mounting kit, flangeless.
SMB600: Surface mounting kit, flanged.
F110: Retrofit flange for B501B, B524.
RA400Z: Remote LED annunciator.
RA400ZA: Remote LED annunciator, ULC Listed.
M02-04-01: Detector test magnet.
M02-09-00: Test magnet with telescoping handle.
XR2B: Detector removal tool (*T55-127-000 included*).
XP-4: Extension pole for XR2B (*5 to 15 ft/1.524 to 4.572 m*).
T55-127-000: Detector removal head.
BCK-200B: Black detector kit.

Junction Box Selection Guide

Base Models	Single-Gang	3.5" Oct.	4.0" Oct.	4.0" Sq.	4.0" Sq. with 3.0" mud ring	50 mm	60 mm	70 mm	75 mm
B501	No	Yes	No	No	Yes	Yes	Yes	Yes	No
B710LP	Yes	Yes	Yes	Yes	Yes	No	No	No	No
B224RB	No	Yes	Yes	Yes	No	No	Yes	Yes	Yes
B224BI	No	Yes	Yes	Yes	No	No	No	Yes	Yes
B501BH, B501BH-2	No	No	No	Yes	No	No	No	No	No
B501BHT, B501BHT-2	No	No	No	Yes	No	No	No	No	No

NOTE: Box depth contingent on base and wire size.
Refer to National Electric Code or applicable local codes for appropriate recommendations.

FlashScan®, NOTIFIER® and System Sensor® are registered trademarks of Honeywell International Inc.
©2006 by Honeywell International Inc. All rights reserved. Unauthorized use of this document is strictly prohibited.



This document is not intended to be used for installation purposes.
We try to keep our product information up-to-date and accurate.
We cannot cover all specific applications or anticipate all requirements.
All specifications are subject to change without notice.

➤ FMM-1(A), FMM-101(A), FZM-1(A) & FDM-1(A)

Monitor Modules with FlashScan®



Intelligent/Addressable Devices

General

Four different monitor modules are available for Notifier's intelligent control panels for a variety of applications. Monitor modules supervise a circuit of dry-contact input devices, such as conventional heat detectors and pull stations, or monitor and power a circuit of two-wire smoke detectors (FZM-1(A)).

FMM-1(A) is a standard-sized module (typically mounts to a 4" [10.16 cm] square box) that supervises either a Style D (Class A) or Style B (Class B) circuit of dry-contact input devices.

➤ **FMM-101(A)** is a miniature monitor module a mere 1.3" (3.302 cm) H x 2.75" (6.985 cm) W x 0.5" (1.270 cm) D that supervises a Style B (Class B) circuit of dry-contact input devices. Its compact design allows the FMM-101(A) to be mounted in a single-gang box behind the device it monitors.

FZM-1(A) is a standard-sized module that monitors and supervises compatible two-wire, 24 volt, smoke detectors on a Style D (Class A) or Style B (Class B) circuit.

FDM-1(A) is a standard-sized dual monitor module that monitors and supervises two independent two-wire Style B (Class B) dry-contact initiating device circuits (IDCs) at two separate, consecutive addresses in intelligent, two-wire systems.

FlashScan® (U.S. Patent 5,539,389) is a communication protocol developed by NOTIFIER that greatly increases the speed of communication between analog intelligent devices. Intelligent devices communicate in a grouped fashion. If one of the devices within the group has new information, the panel CPU stops the group poll and concentrates on single points. The net effect is response speed greater than five times that of other designs.

FMM-1(A) Monitor Module

- Built-in type identification automatically identifies this device as a monitor module to the control panel.
- Powered directly by two-wire SLC loop. No additional power required.
- High noise (EMF/RFI) immunity.
- SEMS screws with clamping plates for ease of wiring.
- Direct-dial entry of address: 01 – 159 on FlashScan loops; 01 – 99 on CLIP loops.
- LED flashes green during normal operation (this is a programmable option) and latches on steady red to indicate alarm.

The FMM-1(A) Monitor Module is intended for use in intelligent, two-wire systems, where the individual address of each module is selected using the built-in rotary switches. It provides either a two-wire or four-wire fault-tolerant Initiating Device Circuit (IDC) for normally-open-contact fire alarm and supervisory devices. The module has a panel-controlled LED indicator. The FMM-1(A) can be used to replace MMX-1(A) modules in existing systems.

FMM-1(A) APPLICATIONS

Use to monitor a zone of four-wire smoke detectors, manual fire alarm pull stations, waterflow devices, or other normally-open dry-contact alarm activation devices. May also be used to monitor normally-open supervisory devices with special supervisory indication at the control panel. Monitored circuit may be wired as an NFPA Style B (Class B) or Style D (Class

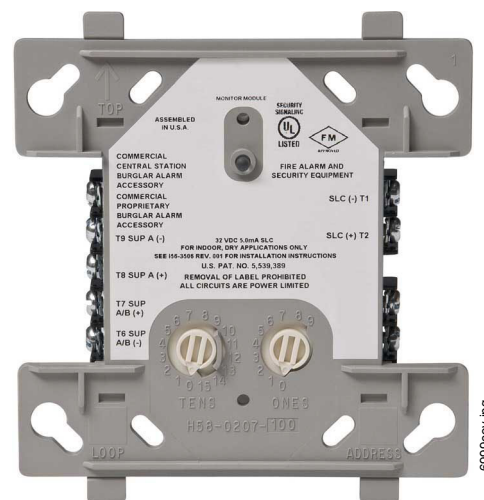

FMM-1(A) (Type H)

A) Initiating Device Circuit. A 47K ohm End-of-Line Resistor (provided) terminates the Style B circuit. No resistor is required for supervision of the Style D circuit.

FMM-1(A) OPERATION

Each FMM-1(A) uses one of the available module addresses on an SLC loop. It responds to regular polls from the control panel and reports its type and the status (open/normal/short) of its Initiating Device Circuit (IDC). A flashing LED indicates that the module is in communication with the control panel. The LED latches steady on alarm (subject to current limitations on the loop).

FMM-1(A) SPECIFICATIONS

Nominal operating voltage: 15 to 32 VDC.

Maximum current draw: 5.0 mA (LED on).

Average operating current: 350 μ A (LED flashing), 1 communication every 5 seconds, 47k EOL.

Maximum IDC wiring resistance: 40 ohms.

EOL resistance: 47K ohms.

Temperature range: 32°F to 120°F (0°C to 49°C).

Humidity range: 10% to 93% noncondensing.

Dimensions: 4.5" (11.43 cm) high x 4" (10.16 cm) wide x 1.25" (3.175 cm) deep. Mounts to a 4" (10.16 cm) square x 2.125" (5.398 cm) deep box.

➤ FMM-101(A) Mini Monitor Module

- Built-in type identification automatically identifies this device as a monitor module to the panel.
- Powered directly by two-wire SLC loop. No additional power required.
- High noise (EMF/RFI) immunity.
- Tinned, stripped leads for ease of wiring.
- Direct-dial entry of address: 01 – 159 on FlashScan loops; 01 – 99 on CLIP loops.

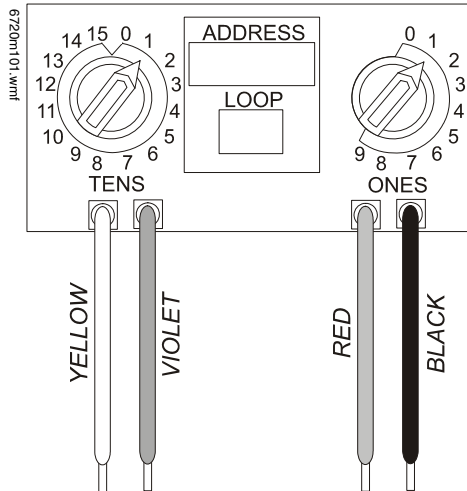

The FMM-101(A) Mini Monitor Module can be installed in a single-gang junction directly behind the monitored unit. Its small size and light weight allow it to be installed without rigid mounting. The FMM-101(A) is intended for use in intelligent, two-wire systems where the individual address of each module is selected using rotary switches. It provides a two-wire initiating device circuit for normally-open-contact fire alarm and security devices. The FMM-101(A) can be used to replace MMX-101(A) modules in existing systems.

FMM-101(A) APPLICATIONS

Use to monitor a single device or a zone of four-wire smoke detectors, manual fire alarm pull stations, waterflow devices, or other normally-open dry-contact devices. May also be used to monitor normally-open supervisory devices with special supervisory indication at the control panel. Monitored circuit/device is wired as an NFPA Style B (Class B) Initiating Device Circuit. A 47K ohm End-of-Line Resistor (provided) terminates the circuit.

FMM-101(A) OPERATION

Each FMM-101(A) uses one of the available module addresses on an SLC loop. It responds to regular polls from the control panel and reports its type and the status (open/normal/short) of its Initiating Device Circuit (IDC).

FMM-101(A) SPECIFICATIONS

Nominal operating voltage: 15 to 32 VDC.

Average operating current: 350 μ A, 1 communication every 5 seconds, 47k EOL; 600 μ A Max. (Communicating, IDC Shorted).

Maximum IDC wiring resistance: 40 ohms.

Maximum IDC Voltage: 11 Volts.

Maximum IDC Current: 400 μ A.

EOL resistance: 47K ohms.

Temperature range: 32°F to 120°F (0°C to 49°C).

Humidity range: 10% to 93% noncondensing.

Dimensions: 1.3" (3.302 cm) high x 2.75" (6.985 cm) wide x 0.65" (1.651 cm) deep.

Wire length: 6" (15.24 cm) minimum.

FZM-1(A) Interface Module

- Supports compatible two-wire smoke detectors.
- Supervises IDC wiring and connection of external power source.
- High noise (EMF/RFI) immunity.
- SEMS screws with clamping plates for ease of wiring.
- Direct-dial entry of address: 01 – 159 on FlashScan loops, 01 – 99 on CLIP loops.
- LED flashes during normal operation; this is a programmable option.
- LED latches steady to indicate alarm on command from control panel.

The FZM-1(A) Interface Module is intended for use in intelligent, addressable systems, where the individual address of each module is selected using built-in rotary switches. This module allows intelligent panels to interface and monitor two-wire conventional smoke detectors. It transmits the status (normal, open, or alarm) of one full zone of conventional detectors back to the control panel. All two-wire detectors being monitored must be UL compatible with the module. The FZM-1(A) can be used to replace MMX-2(A) modules in existing systems.

FZM-1(A) APPLICATIONS

Use the FZM-1(A) to monitor a zone of two-wire smoke detectors. The monitored circuit may be wired as an NFPA Style B (Class B) or Style D (Class A) Initiating Device Circuit. A 3.9 K ohm End-of-Line Resistor (provided) terminates the end of the Style B or D (class B or A) circuit (maximum IDC loop resistance is 25 ohms). Install ELR across terminals 8 and 9 for Style D application.

FZM-1(A) OPERATION

Each FZM-1(A) uses one of the available module addresses on an SLC loop. It responds to regular polls from the control panel and reports its type and the status (open/normal/short) of its Initiating Device Circuit (IDC). A flashing LED indicates that the module is in communication with the control panel. The LED latches steady on alarm (subject to current limitations on the loop).

FZM-1(A) SPECIFICATIONS

Nominal operating voltage: 15 to 32 VDC.

Maximum current draw: 5.1 mA (LED on).

Maximum IDC wiring resistance: 25 ohms.

Average operating current: 300 μ A, 1 communication and 1 LED flash every 5 seconds, 3.9k eol.

EOL resistance: 3.9K ohms.

External supply voltage (between Terminals T3 and T4): DC voltage: 24 volts power limited. Ripple voltage: 0.1 Vrms maximum. Current: 90 mA per module maximum.

Temperature range: 32°F to 120°F (0°C to 49°C).

Humidity range: 10% to 93% noncondensing.

Dimensions: 4.5" (11.43 cm) high x 4" (10.16 cm) wide x 1.25" (3.175 cm) deep. Mounts to a 4" (10.16 cm) square x 2.125" (5.398 cm) deep box.

FDM1(A) Dual Monitor Module

The FDM-1(A) Dual Monitor Module is intended for use in intelligent, two-wire systems. It provides two independent two-wire initiating device circuits (IDCs) at two separate, consecutive addresses. It is capable of monitoring normally open contact fire alarm and supervisory devices; or either normally open or normally closed security devices. The module has a single panel-controlled LED.

NOTE: The FDM-1(A) provides two Style B (Class B) IDC circuits ONLY. Style D (Class A) IDC circuits are NOT supported in any application.

FDM-1(A) SPECIFICATIONS

Normal operating voltage range: 15 to 32 VDC.

Maximum current draw: 6.4 mA (LED on).

Average operating current: 750 μ A (LED flashing).

Maximum IDC wiring resistance: 1,500 ohms.

Maximum IDC Voltage: 11 Volts.

Maximum IDC Current: 240 μ A

EOL resistance: 47K ohms.

Maximum SLC Wiring resistance: 40 Ohms.

Temperature range: 32° to 120°F (0° to 49°C).

Humidity range: 10% to 93% (non-condensing).

Dimensions: 4.5" (11.43 cm) high x 4" (10.16 cm) wide x 2.125" (5.398 cm) deep.

FDM-1(A) AUTOMATIC ADDRESSING

The FDM-1(A) automatically assigns itself to two addressable points, starting with the original address. For example, if the FDM-1(A) is set to address "26", then it will automatically assign itself to addresses "26" and "27".

NOTE: "Ones" addresses on the FDM-1(A) are 0, 2, 4, 6, or 8 only. Terminals 6 and 7 use the first address, and terminals 8 and 9 use the second address.



CAUTION:

Avoid duplicating addresses on the system.

Installation

FMM-1(A), FZM-1(A), and FDM-1(A) modules mount directly to a standard 4" (10.16 cm) square, 2.125" (5.398 cm) deep, electrical box. They may also be mounted to the SMB500 surface-mount box. Mounting hardware and installation instructions are provided with each module. All wiring must conform to applicable local codes, ordinances, and regulations. These modules are intended for power-limited wiring only.

The FMM-101(A) module is intended to be wired and mounted without rigid connections inside a standard electrical box. All wiring must conform to applicable local codes, ordinances, and regulations.

Agency Listings and Approvals

In some cases, certain modules may not be listed by certain approval agencies, or listing may be in process. Consult factory for latest listing status.

- **UL:** S635
- **ULC:** S635
- **FM Approved**
- **CSFM:** 7300-0028:0219
- **MEA:** 457-99-E
- **U.S. Coast Guard:**

– 161.002/23/3 (AFP-200: FMM-1/-101, FZM-1)

– 161.002/42/1 (NFS-640: FMM-1/-101)

- **Lloyd's Register:**

– 03/60011/E1 (FMM-1/-101, FZM-1)

– 94/60004/E2 (AFP-200: except FDM-1)

– 02/60007 (NFS-640: FDM-1)

- **FDNY:** COA #6038 (NFS2-640, NFS-320), COA# 6058 (NFS2-3030)

Product Line Information

NOTE: "A" suffix indicates ULC-listed model.

FMM-1(A): Monitor module.

FMM-101(A): Monitor module, miniature.

FZM-1(A): Monitor module, two-wire detectors.

FDM-1(A): Monitor module, dual, two independent Class B circuits.

SMB500: Optional surface-mount backbox.

NOTE: See installation instructions and refer to the SLC Wiring Manual, PN 51253.

FlashScan® and NOTIFIER® are registered trademarks and FireWatch™ is a trademark of Honeywell International Inc.
©2010 by Honeywell International Inc. All rights reserved. Unauthorized use of this document is strictly prohibited.



This document is not intended to be used for installation purposes.
We try to keep our product information up-to-date and accurate.
We cannot cover all specific applications or anticipate all requirements.
All specifications are subject to change without notice.



Wheelock® Exceder™

Horns and Strobes



Audio/Visual Devices

General

The Wheelock® Exceder™ Series of notification appliances feature a sleek modern design and numerous features including eight candela options in one appliance, low current draw, no tools needed for setting changes, 12/24 VDC operation, universal mounting base and multiple mounting options.

Models with an audible feature 3 sound settings (90, 95, 99 dB). All switches to change settings can be set without the use of a tool and are located behind the appliance to prevent tampering. Wall models feature voltage test points to take readings with a voltage meter for troubleshooting and AHJ inspection.

The Wheelock® Exceder™ Series of wall and ceiling notification appliances feature a Universal Mounting Base (UMB) designed to simplify the installation and testing of horns, strobes, and combination horn strobes. The separate universal mounting base can be pre-wired to allow full testing of circuit wiring before the appliance is installed and the surface is finished. It comes complete with a contact cover for protection against dirt, dust, paint and damage to the contacts. The contact cover also acts as a shunting device to allow pre-wire testing for common wiring issues.

The contact cover is polarized to prevent it from being installed incorrectly and prevents the appliance from being installed while it is on the UMB. When the contact cover is removed the circuit will show an open until the appliance is installed. The UMB allows for consistent installation and easy replacement of appliances if required. Wall models provide an optional locking screw for extra secure installation, while the ceiling models provide a captive screw to prevent the screw from falling during installation.

Features

- Multiple voltages
- Voltage test points for quick troubleshooting and easy spot-checking (wall models only)
- 3 audible settings (90, 95, 99 dB)
- 8 Candela settings
 - Wall - 15/1575/30/75/95/110/135/185
 - Ceiling - 15, 30, 60, 75, 95, 115, 150, 177
- Finger-slide switches
- Sleek modern aesthetics
- Common base for wall and ceiling with 5 mounting options:
 - 1-gang
 - 2-gang
 - 4 inch square
 - 3.5 inch octagonal
 - 4 inch octagonal

Compatibility and Requirements

- Synchronize using Wheelock Sync Modules, or panels with built-in Wheelock patented sync protocol.
- Compatible with UL “Regulated Voltage” using filtered VDC or unfiltered VRMS input voltage
- Strobes produce one flash per second over the Regulated Voltage range.



Wall



Ceiling



General Notes

- All candela ratings represent minimum effective strobe intensity based on UL Standard 1971.
- Series Exceder Strobe products are Listed under UL Standards 1971 and 464 for indoor use with a temperature range of 32°F to 120°F (0°C to 49°C) and maximum humidity of 93% (± 2%) UL 464 (85% UL 1971).
- Series Exceder horns are under UL Standard 464 for audible signal appliances (Indoor use only).
- Product naming conventions: The Exceder line's model codes break down into easy-to-remember codes. HN = Horn, ST = Strobe, HS = Horn-strobe, C = Ceiling Mount, W = White, and R = Red. So “STRC” can be read as “Strobe, Red, Ceiling-mount.”, and “HSW” is “Horn-strobe, white, wall-mount.”
- Refer to your fire alarm panel or power supply manual when calculating the number of devices allowed per circuit.

Architects/Engineers Specifications

The notification appliances shall be Wheelock Exceder Series HS Audible Strobe appliances, Series ST Visual Strobe appliances and Series HN Audible appliances or approved equals. The Series HS and ST Strobes shall be listed for UL Standard 1971 (Emergency Devices for the Hearing-Impaired) for Indoor Fire Protection Service. The Series HS and HN Audibles shall be UL Listed under Standard 464 (Fire Protective Signaling). All Series shall meet the requirements of FCC Part 15 Class B. All inputs shall be compatible with standard reverse polarity supervision of circuit wiring by a Fire Alarm Control Panel (FACP) with the ability to operate from 8 to 33 VDC. Indoor wall models shall incorporate voltage test points for easy voltage inspection.

The Series HS Audible Strobe and ST Strobe appliances shall produce a flash rate of one flash per second over the Regulated Voltage Range and shall incorporate a Xenon flashtube enclosed in a rugged Lexan® lens. The Series shall be of low current design. Where Multi-Candela appliances are specified, the strobe intensity shall have 8 field selectable settings at 15,

15/75, 30, 75, 95, 110, 135, 185 candela for wall mount and 15, 30, 60, 75, 95, 115, 150, 177 candela for ceiling mount. The selector switch for selecting the candela shall be tamper resistant. The 15/75 candela strobe shall be specified when 15 candela UL Standard 1971 Listing with 75 candela on-axis is required (e.g. ADA compliance). Appliances with candela settings shall show the candela selection in a visible location at all times when installed.

The audible shall have a minimum of three field selectable settings for dBA levels and shall have a choice of continuous or temporal (Code 3) audible outputs.

MOUNTING OPTIONS

The Series HS Audible Strobe, ST Strobe and Series HN Audible shall incorporate a patented Universal Mounting Base that shall allow mounting to a single-gang, double-gang, 4" square, 3.5" octagonal, 4" octagonal or 100mm European type back boxes. Two wire appliance wiring shall be capable of directly connecting to the mounting base. Continuity checking of the entire NAC circuit prior to attaching any notification appliances shall be allowed. Product shall come with contact cover to protect contact springs. Removal of an appliance shall result in a supervision fault condition by the Fire Alarm Control Panel (FACP). The mounting base shall be the same base among all horn, strobe, horn strobe, wall and ceiling models. All notification appliances shall be backwards compatible.

PHYSICAL SPECIFICATIONS

The Series HS and ST wall models shall have a low profile measuring 5.24" H x 4.58" W x 2.19" D. Series HN wall shall measure 5.24" H x 4.58" W x 1.6" D. The Series HSC and STC

shall be round and have a low profile with a diameter of 6.68" x 2.63" D. Series HNC ceiling shall have a diameter of 6.68" x 1.50" D.

SYNCHRONIZATION

When synchronization is required, the appliance shall be compatible with Wheelock® SM, DSM Sync Modules, Wheelock® Power Supplies or other manufacturer's panels with built-in Wheelock® Patented Sync Protocol. The strobes shall not drift out of synchronization at any time during operation. If the sync protocol fails to operate, the strobe shall revert to a non-synchronized flash-rate and still maintain one flash per second over its Regulated Voltage Range. The appliance shall also be designed so that the audible signal may be silenced while maintaining strobe activation when used with Wheelock® synchronization protocol.

Standards and Codes

Modules in this series comply with UL Standard 1971, UL Standard 464, California State Fire Marshal (CSFM), and ULC.

Agency Listings

These listings and approvals apply to the modules specified in this document. In some cases, certain modules or applications may not be listed by certain approval agencies, or listing may be in process. Consult factory for latest listing status.

- **UL Listed:** S5391 (Strobes); E5946 (Horns, Horn/strobes).
- **ULC Listed**
- **CSFM Listed:** 7125-0785:168.

Specification & Ordering Information

Model	Strobe Candela	12/24 VDC	Mounting Options
Horn Strobes			
HSR	15, 15/75, 30, 75, 95, 110, 135, 185	X	Universal Mounting Base
HSW	15, 15/75, 30, 75, 95, 110, 135, 185	X	Universal Mounting Base
HSRC	15, 30, 60, 75, 95, 115, 150, 177	X	Universal Mounting Base
HSWC	15, 30, 60, 75, 95, 115, 150, 177	X	Universal Mounting Base
Strobes			
STR	15, 15/75, 30, 75, 95, 110, 135, 185	X	Universal Mounting Base
STW	15, 15/75, 30, 75, 95, 110, 135, 185	X	Universal Mounting Base
STRC	15, 30, 60, 75, 95, 115, 150, 177	X	Universal Mounting Base
STWC	15, 30, 60, 75, 95, 115, 150, 177	X	Universal Mounting Base
Horns			
HNR	—	X	Universal Mounting Base
HNW	—	X	Universal Mounting Base
HNRC	—	X	Universal Mounting Base
HNWC	—	X	Universal Mounting Base
*12 VDC models feature 15 and 15/75 settings			
NOTE: Due to continuous development of Cooper Wheelock products, specifications and offerings are subject to change without notice in accordance with Cooper Wheelock Inc., dba Cooper Notification standard terms and conditions.			

Notifier® is a registered trademark of Honeywell International Inc.
 Exceder is a trademark and Wheelock® is a registered trademark of Cooper Notification.
 ©2010 by Honeywell International Inc. All rights reserved. Unauthorized use of this document is strictly prohibited.

This document is not intended to be used for installation purposes.
 We try to keep our product information up-to-date and accurate.
 We cannot cover all specific applications or anticipate all requirements.
 All specifications are subject to change without notice.





AdaptaBeacon® Flashing Incandescent Lights

**PLC Compatible
NEMA Type 4X**

➤ 48FIN Series

FEATURES

- > Weatherproof
- > 25W Halogen lamp in 120V AC Model; 20W Halogen lamp in 24V AC and 24V DC Models
- > Snap-on high impact polycarbonate/ABS base
- > Shatter resistant polycarbonate lens

AGENCY APPROVALS

- > UL 1638 Listed
- > UL Listed NEMA Type 4X enclosure
- > cUL Listed

The Edwards 48 Series AdaptaBeacon flashing lights incorporate a unique double fresnel lens that has been optically engineered to maximize brilliance. This is accomplished with a series of complementing fresnels that cause the dome to "fill" when the light is operating. Beam distance is also increased with fresnel lenses. The incandescent lights are available in six colors: red, amber, blue, green, magenta, and clear.

Designed for indoor or outdoor installation. May be direct or 1/2" (13mm) conduit mounted. For weatherproof installation, units must be mounted vertically with the lens facing up. Use Cat. No. GSK-KIT gasket kit for weatherproof surface installation of AC models. May be corner mounted indoors using the Cat. No. CBR, corner mount bracket, or wall mounted indoors using the Cat. No. WBR, wall mount bracket. See Adaptabeacon Accessories, page 3-118.

Edwards flashing lights are particularly effective in high noise level areas, especially where ear protection must be worn and audible signals may not be heard or understood. They can advise personnel in manufacturing and process areas when an operation is starting or stopping. Often used to signal malfunctions in equipment, such as assembly line jams. Can warn personnel that they are entering a restricted area or an area of high danger. May be used where a smaller light output is desired or where many multiple smaller flashing lights are specified. The gasketed NEMA 4X enclosure ensures installation acceptability in most industrial and commercial locations.

D-04



TECHNICAL INFORMATION

Use Cat. No. GSK-KIT gasket kit for weatherproof surface mount installation on AC units

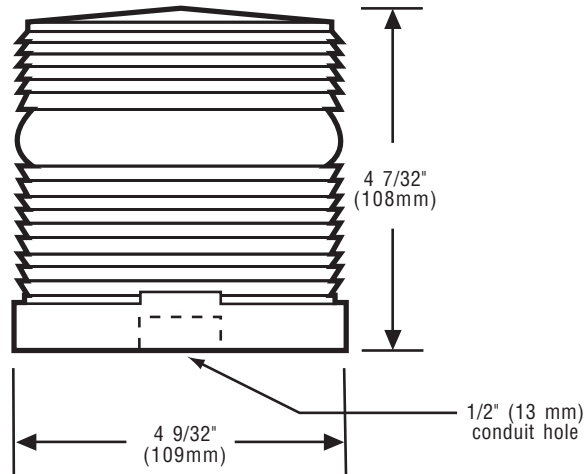

Cat. No.	Lens Color	Replacement Lens	Lamp Ratings	Replacement Flasher	Electrical Ratings	Replacement Lamp
48FINR-N5-25WH	Red	96-LR	25 watts	P-041917-0026	120V 50/60 Hz	50LMP-25WH
48FINA-N5-25WH	Amber	96-LA	175 Lumens*		0.20 Amps	or
48FINB-N5-25WH	Blue	96-LB	2198 candlepower			Ind. Trade
48FING-N5-25WH	Green	96-LG	25,000 hr.**			No. 25T8DC
48FINM-N5-25WH	Magenta	96-LM				
48FINC-N5-25WH	Clear	96-LC				
48FINR-G5-20WH	Red	96-LR	20 Watts	P-041917-0029	24V 50/60 Hz	50LMP-20WH
48FINA-G5-20WH	Amber	96-LA	226 Lumens*		0.80 Amps	or
48FINB-G5-20WH	Blue	96-LB	2839 candlepower			Ind. Trade
48FING-G5-20WH	Green	96-LG	25,000 hr.**			No. 1692
48FINM-G5-20WH	Magenta	96-LM				
48FINC-G5-20WH	Clear	96-LR				
48FINR-E1	Red	96-LR	13 watts	P-041917-0028	12V DC	Ind. Trade
48FINA-E1	Amber	96-LA	189 Lumens*		1.0 Amps	No. 94
48FINB-E1	Blue	96-LB	2374 candlepower			
48FING-E1	Green	96-LG	1,520 hr.**			
48FINM-E1	Magenta	96-LM				
48FINC-E1	Clear	96-LC				
48FINR-G1-20WH	Red	96-LR	20 watts	P-041917-0029	24V DC	50LMP-20WH
48FINA-G1-20WH	Amber	96-LA	226 Lumens*		0.80 Amps	or
48FINB-G1-20WH	Blue	96-LB	2839 candlepower			Ind. Trade
48FING-G1-20WH	Green	96-LG	25,000 hr.**			No. 1692
48FINM-G1-20WH	Magenta	96-LM				
48FINC-G1-20WH	Clear	96-LC				

*Bulb manufacturer's lumen rating.

**Projected lamp life based on manufacturer's calculated lamp life at 65 fpm and 50% duty cycle.

SIGNAL INPUT LOAD CHARACTERISTICS*

Cat. No.	Operating Voltage	Max. off state leakage current (mA)	Continuous on Current (mA)	Surge (inrush/duration) Amps/milliseconds
48FIN(-)-G1-20WH	24V DC	25	800	2.2/100
48FIN(-)-N5-25WH	120V AC 60 Hz	25	200	1.3/8

*This device is PLC compatible and may be operated by PLCs with output characteristics that match the input load requirements of this signal.

**NO
EXCUSES!**



FAD

Fire Alarm Documents Records / Programs / Software

The FAD is the perfect fit to meet the demanding code requirements today. SAE's number one goal is to manufacture code compliant solutions and this product allows you to do just that. NFPA 72 section 6.2.2.1 states, "A record of installed software and firmware version numbers shall be maintained at the location of the fire alarm control unit."

This durable 16 gauge steel enclosure with a solid piano hinge and key lock will keep all of your code required documents in one safe place. With a 2GB USB flash drive it stores your fire alarm software safe and secure eliminating the occurrences of the software not being on site when technicians arrive to service the system. Along with your fire alarm software you can store your test & inspection documents, service records, manuals & AS built drawings for the system. Using a standard USB B connector it allows you to plug in with any standard SB printer cable to upload or download information.

NFPA 72 section 10.18.2.1.2.8 If the documents are located in a separate enclosure or cabinet, the separate enclosure or cabinet shall be prominently labeled
FIRE ALARM DOCUMENTS.

Standard Features:

- Installed with a 2 gig digital flash drive with USB B connector
- 2 Key ring hooks to hold system keys
- Business card holder for key contacts
- Overall Dimensions are 12" x 13" tall and 2 ¼ deep
- 16 gauge steel box and cover for security
- durable powercoat baked on finish other colors available
- standard ¾" cat 30 key lock other lock assemblies available
- Solid stainless steel piano hinge
- permanently screened white ink 1" high "Fire Alarm Documents"
- Legend sheet for passwords and system information

The FAD is designed to hold critical manuals and documents with a durable steel sleeve. It has designated hooks to organize key rings and hold important business cards for easy access and reference. Inside the cover it has a organized note table that allows for documentation for passwords and other critical system information. The steel sleeve can be easily removed to hold a 1.5" three ring binder.

The innovation of a single gang cutout inside the box to implement the infinity line products with conduit knockout access enables you to provide other system functions for test and inspection. A drill switch or a shut off switch for testing are just a few examples. See the complete line of Infinity products for single gang electrical product solutions.



**ISO 9001
REGISTERED
COMPANY**



ACEBOX

Specifications:

The Fire Alarm Document Box (FAD) shall be constructed of 18 gauge cold rolled steel, it shall have a red powder coat epoxy finish. The cover shall be permanently screened with 1" high lettering "FIRE ALARM DOCUMENTS" with indelible ink. The access door shall be locked with a 3/4" barrel lock and the hinge shall be a solid width 12" stainless steel piano hinge. The enclosure will supply 4 mounting holes.

Inside the enclosure a removable steel sleeve that will accommodate standard 8 1/2 x 11 manuals and loose document records that will be protected within the enclosure. A legend sheet permanently attached to the door for system passwords and critical information and inspection notes. The FAD will have permanently and securely mounted inside a minimum of 2GB's digital flash memory drive with a standard USB B connector for uploading and downloading information. The drive shall not be accessible without tools to any person whom gains access to the records. The enclosure shall also provide 2 key ring holders with a location to mount standard business type cards for key contact personell.

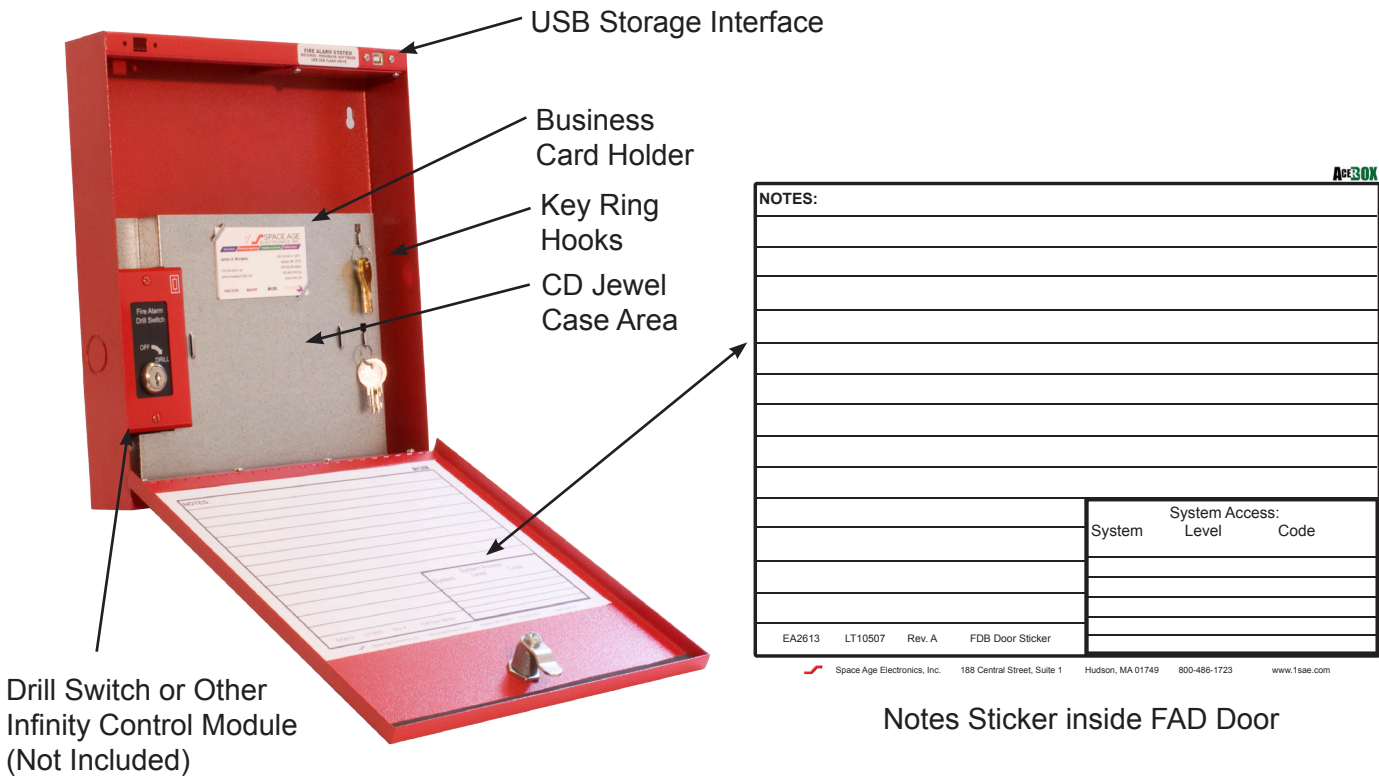

Notes Sticker inside FAD Door

Ordering Information:

Part # Description

➤ **SSU00685 Fire Alarm Storage Cabinet RED**

SSU00673 Custom screening with your Logo

Check out our Infinity line eFAD single gang 2 Gig digital storage solutions (IAMEFAD)



High Security Commercial Key Vault

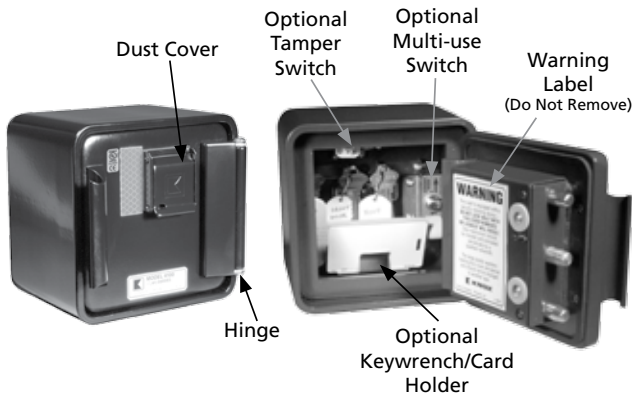

A new Knox-Box that's for those applications where a 3200 Series is too small yet the 4400 Series too large. The high security 4100 Series has a hinged-door allowing for the convenient single-handed operation. The 4100 Series Knox-Vault protects and stores building keys, access cards and the Knox FDC Keywrench allowing departments to keep a keywrench on site.

Features and Benefits

- Holds up to 24 keys in the large interior compartment
- Ensures high security with UL listed Medeco lock(s)
- Includes Knox-Coat® that is four times better than standard powder coat
- Resists moist conditions with a weather resistant silicone door gasket
- Colors: **Black** Dark Bronze or Aluminum
- Weight: Surface mount - 17 lbs.
Recessed mount - 19 lbs.

Options

- Alarm Tamper Switches (U/L listed)
- Recessed Mounting Kit (RMK) for recessed models only
- Dual lock configuration
- Access card holder
- Keywrench holder

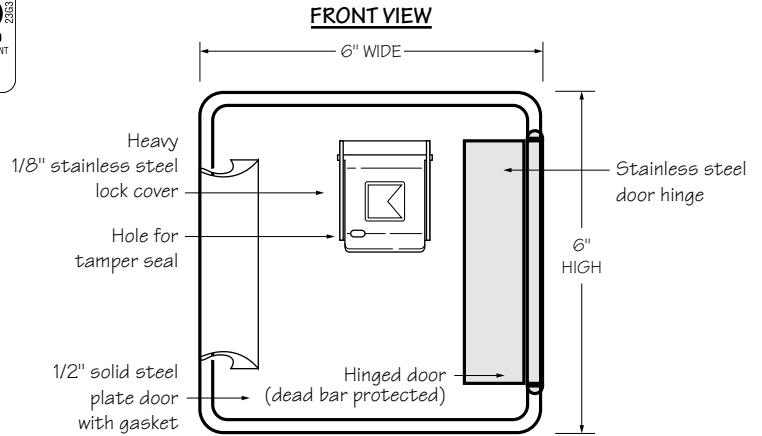

4100 Surface Mount

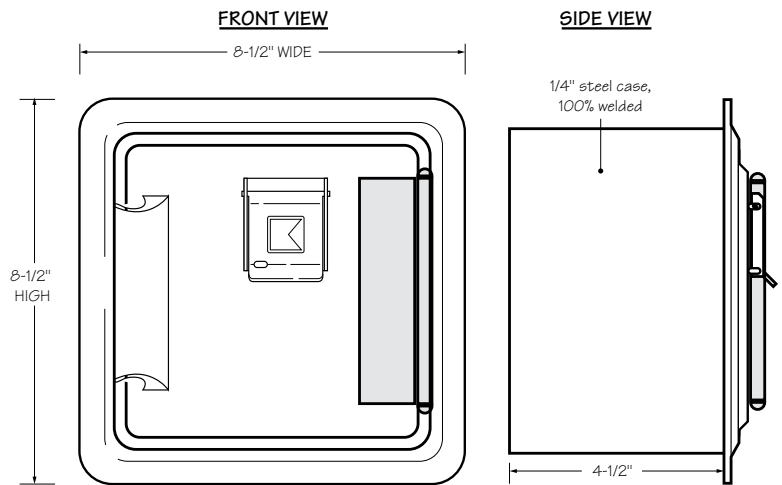

➤ **4100 Recessed Mount**

Ordering Specifications

To ensure procurement and delivery of the 4100 Series Knox-Vault, it is suggested that the following specification paragraph be used:

KNOX-VAULT surface/recessed mount, with/without UL Listed tamper switches. 1/4" plate steel housing, 1/2" thick solid steel door with interior silicone gasket seal. Lock UL listed. Lock has 1/8" thick stainless steel dust cover with tamper seal mounting capability. Vault has anti-theft re-locking mechanism with drill resistant hard-plate lock protector.

Exterior Dimensions: Surface mount – 6"H x 6"W x 4 1/2"D
Recessed mount – 8 1/2"H x 8 1/2"W x 4 1/2"D

Lock: UL Listed. Double-action rotating tumblers and hardened steel pins accessed by a proprietary coded biased cut key.

Finish: Knox-Coat® proprietary finishing process
Finish Color - Black, Dark Bronze or Aluminum

P/N: 4100 Series Knox-Vault (mfr's cat. ID)

Mfr's Name: **KNOX COMPANY**

**Suggested minimum mounting height
6 feet above ground**

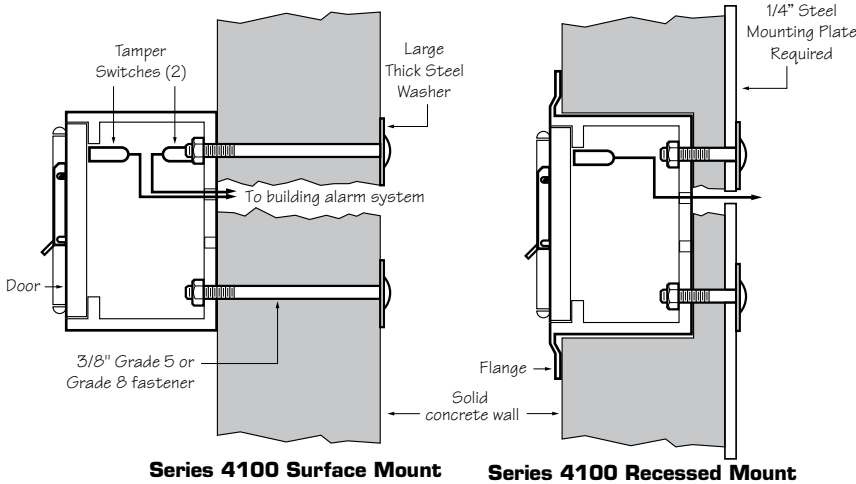

INSIDE VIEW

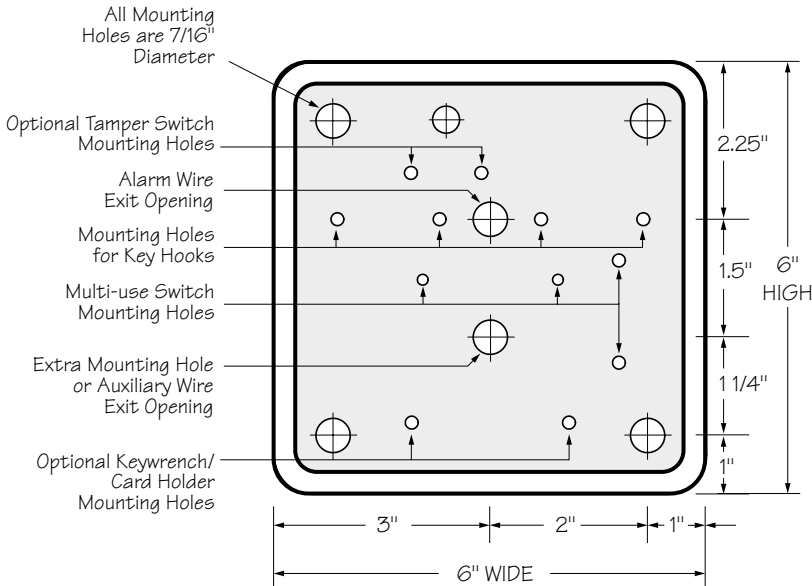

Attention: KNOX-BOX® key box is a very strong device that MUST be mounted properly to ensure maximum security and resist physical attack.

Knox® Rapid Entry System

The Knox Company manufactures a complete line of high security products including Knox-Box key boxes, key vaults, cabinets, key switches, padlocks, locking FDC caps, plugs and electronic master key security systems. For more information or technical assistance, please call Customer Service at 1-800-552-5669.

➤ Recessed Mounting Kit

The 4100 Recessed Mounting Kit (RMK) is used for recessed models only. It contains a shell housing and mounting hardware to be cast-in-place in new concrete or masonry construction. After construction is completed, the Knox-Vault mounts inside the recessed shell housing. The RMK may only be used in new concrete or masonry construction.

Installation In Cast Concrete

The optional Recessed Mounting Kit is for use in new concrete or masonry construction only. The kit includes a shell housing and mounting hardware to be cast-in-place. The KNOX-VAULT is mounted into the shell housing after construction is completed.

RMK Exterior Dimensions

6 5/8" H x 7 1/4" W x 5 1/4" D

IMPORTANT: Care should be taken to insure that the front of the RMK shell housing, including the cover plate and screw heads, is flush with the finish wall. The RMK must be plumbed to insure vertical alignment of the vault.

Recessed Mounting Using Recessed Mounting Kit (RMK)

KNOX-VAULT® mounts inside RMK shell after completion of construction

RMK shell is mounted in wall during new construction

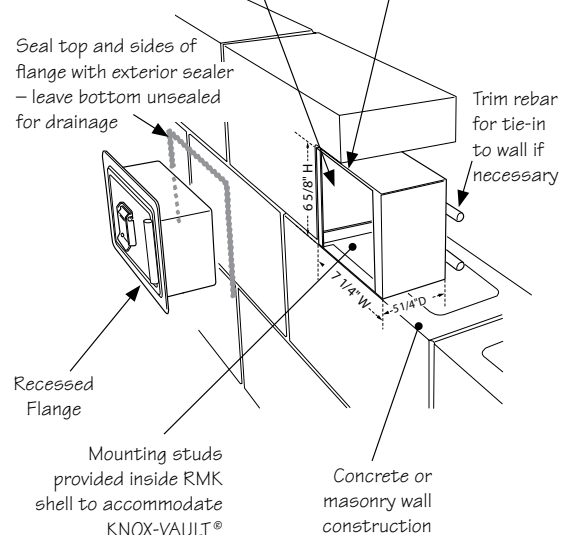

➤ 7788F/7744F Series

Wireless Fire Alarm Communicators for AES-IntelliNet

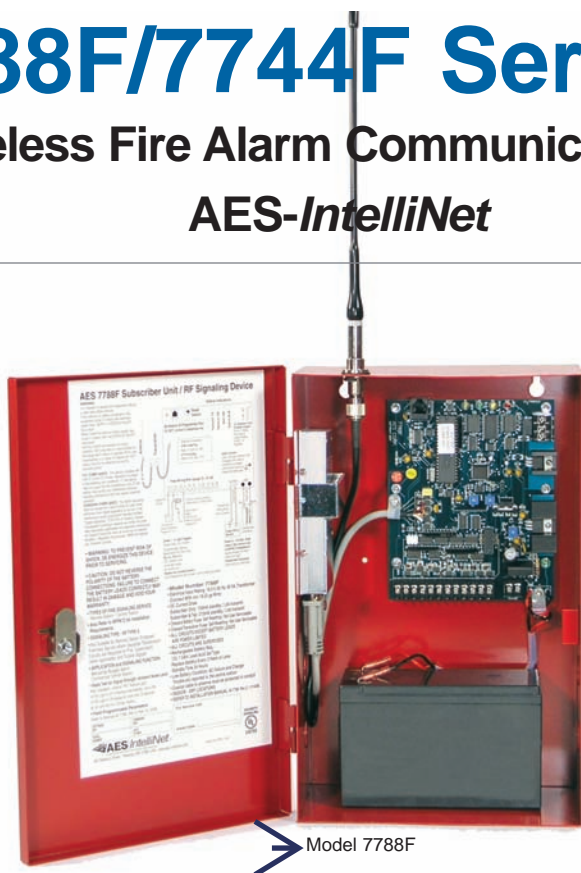

Advanced Wireless Alarm Monitoring

The AES-IntelliNet mesh radio network offers unmatched reliability and speed in delivering wireless alarm signals to a central station without third party fees or reliance on networks owned by companies outside the security and fire alarm industry. AES-7788F/7744F Series Smart Subscriber Transceivers provide the wireless communication link between the fire alarm panel and the central station receiver. The 7788F/7744F Series is ideal for most commercial fire alarm applications. Each 7788F/7744F Series Subscriber is housed in a full sized, red, locked, steel cabinet and supports a range of alarm panel inputs including EOL fire, EOL supervised, and direct voltage from the panel (non-fire applications).

Supervised Operation

AES Smart Subscribers offer fully supervised operation that includes monitoring of operating power (both primary AC power and battery backup) and the connection to the radio network. Each Subscriber “checks in” with the AES central station receiver at least once every 24 hours. The supervision check in time can be set for as often as once per minute and, because the central station owns the wireless network, there is no additional cost for air time to transmit supervisory signals.

Full Data Reporting from Alarm Panel Digital Dialer

Models 7788F-ULP and 7744F-ULP come equipped with an IntelliPro Fire Full Data Module (AES-7794) which enables reporting of full alarm data captured from the fire alarm panel's digital communicator. IntelliPro Fire supports most alarm communication formats including Contact ID, Pulse, as well as Bosch Modem IIe and Modem IIIa2.



Features – All models

- UL Listed commercial fire alarm applications.
- Meets NFPA 72 requirements
- Direct reporting to AES receiver across IntelliNet wireless mesh network
- Each Subscriber acts as transmitter/receiver/repeater
- Simple and fast activation on network
- On board status LEDs for easy set up
- 8 programmable zone inputs – 7788F
- 4 programmable zone inputs and 4 reverse polarity inputs – 7744F
- Easy programming via AES handheld programmer or PC
- Rugged metal housing ideal for any commercial fire alarm application

Models 7788F/7744F-ULP with IntelliPro Fire also includes

- IntelliPro Fire transmits full alarm data from virtually any fire alarm panel digital communicator
- Alarm format support for Contact ID, Pulse, or Bosch Modem IIe or Modem IIIa2
- Easy installation in AES subscriber
- Operates in applications with or without a phone line



Wireless mesh networking is an innovative technology adopted by many industries with applications that need to communicate data over a large geographic area with a high level of reliability at a low total cost of ownership.

The advanced design and 2-way communications capability provides easy installation, expansion, and management when compared to alternative communication methods, both wired and wireless.

7788F/7744F Series



Technical Specifications

7788F/7744F Series Subscribers

Dimensions

- 13.25"H x 8.5"W x 4.3"D
(34cm H x 21.5cm W x 11cm D)

Weight

- Approx. 7 pounds (3.2 kilograms), excludes battery.

Radio Frequency

- Standard Frequency Range: 450-470MHz (others available)
- Output Power - 2 Watts (others available)

Antenna

- Included 2.5 db tamper resistant antenna mounts on enclosure
- Multiple remote antenna options available

Power Input

- 16.5VAC, 40VA (transformer not included)

Backup Battery

- Will charge 12V battery up to 7.5 AH. Requires 12VDC 7.5 AH battery for UL 864.

Alarm Signal Inputs (subscriber)

- 7788F – 8 individually programmable zones
- 7744F - 4 individually programmable zones and 4 reverse polarity inputs

UL Standards

- UL 864 Edition 9 – Standard for Control Units and Accessories for Fire Alarm Systems
- UL 365 – Standard for Police Station Connected Burglar Alarm Units and Systems
- UL 1681 – Standard for Central Station Burglar Alarm Units

Antenna Cut / Communication

Trouble Output

- Form C relay; fail secure; rated for 24 VDC 1A resistive

Reset Button

- Located on main circuit board.

Operating Temperature

- 0° to 50° C (32° to 122°F)

Storage Temperature

- -10° to 60° C (14° to 140°F)

Relative Humidity

- 0 to 85% RHC, Non Condensing

AES-7794 IntelliPro Fire

Input / Output Connections

- RJ11 connection to AES subscriber for module data and power
- RJ11 connector for Handheld Programmer/PC programming
- RJ31X Telco connections - T and R both in and out via terminal strip and RJ45
- Alarm Panel digital communicator T and R both in and out via terminal strip and RJ45
- Trouble output: Form C relay detects if Subscriber is off the network

Alarm Formats

- Support for Contact ID and Pulse formats as well as Modem IIe and Modem IIIa2 converted to CID

Size

- 2.8 x 5.0 inches (7.1cm x 12.7cm)

Power Requirements

- 12 VDC nominal - primary and backup power provided by the AES 7788F/7744F or other Subscriber

How to Order

Model	Description
7744F	4 Zone Fire Alarm Subscriber with 4 reverse polarity inputs
7744F-ULP	7744F Fire Alarm Subscriber with IntelliPro Fire full data module
7788F	8 Zone Fire Alarm Subscriber
7788F-ULP	7788F Fire Alarm Subscriber with IntelliPro Fire full data module

Optional Accessories

7041E	Subscriber Handheld Programmer
7794	IntelliPro Fire Full Data Module



AES-IntelliNet™ is the industry leader in delivering high quality wireless mesh networks to the fire and security industry in commercial, corporate, government, and educational applications with its broad line of products and advanced network management tools. Users of AES-IntelliNet networks have gained significant revenue, communications, and cost advantages while meeting the high standards of reliability required for the fire and security industry. AES-IntelliNet alarm monitoring systems are deployed at hundreds of thousands of locations in over 150 countries.



➤ ELK-TRG1640 16.5VAC, 45 VA



ELK-TRG1640

- Auto-Resetting (PTC) Fused Secondary
- Green Power On LED
- Grounding Prong & Terminal
- Electrical outlet mounting tab
- UL Listed
- Wire Strain Relief
- Lifetime Limited Warranty

Specifications:

- Input Voltage: 120 VAC, 60Hz, .43W.
- Output Voltage: TRG1640 = 16.5 Volts A.C.
TRG2440 = 24 Volts A.C.
- Output Power: TRG1640 = 45 VA.
TRG2440 = 40 VA.
- Size: H=4.14"(105), W=2.74"(70), D=2.2"(56)
- Color: White

➤ FCM-1(A) & FRM-1(A) Series

Control and Relay Modules



Intelligent / Addressable Devices

General

FCM-1(A) Control Module: The FCM-1(A) Addressable Control Module provides Notifier intelligent fire alarm control panels a circuit for Notification Appliances (horns, strobes, speakers, etc.). Addressability allows the FCM-1(A) to be activated, either manually or through panel programming, on a select (zone or area of coverage) basis.

➤ **FRM-1(A) Relay Module:** The FRM-1(A) Addressable Relay Module provides the system with a dry-contact output for activating a variety of auxiliary devices, such as fans, dampers, control equipment, etc. Addressability allows the dry contact to be activated, either manually or through panel programming, on a select basis.

FlashScan® (U.S. Patent 5,539,389) is a communication protocol developed by NOTIFIER Engineering that greatly enhances the speed of communication between analog intelligent devices. Intelligent devices communicate in a grouped fashion. If one of the devices within the group has new information, the panel CPU stops the group poll and concentrates on single points. The net effect is response speed greater than five times that of other designs.

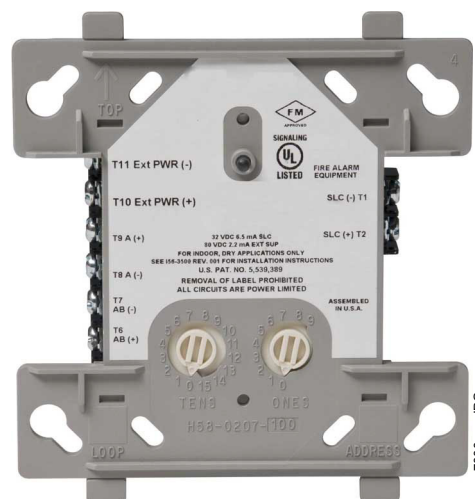

FCM-1(A)

Features

- Built-in type identification automatically identifies these devices to the control panel.
- Internal circuitry and relay powered directly by two-wire SLC loop. The FCM-1(A) module requires power (for horns, strobes, etc.), or audio (for speakers).
- Integral LED “blinks” green each time a communication is received from the control panel and turns on in steady red when activated.
- LED blink may be deselected globally (affects all devices).
- High noise immunity (EMF/RFI).
- The FCM-1(A) may be used to switch 24-volt NAC power, audio (up to 70.7 Vrms).
- Wide viewing angle of LED.
- SEMS screws with clamping plates for wiring ease.
- Direct-dial entry of address 01– 159 for FlashScan loops, 01 – 99 for CLIP mode loops.
- Speaker, and audible/visual applications may be wired for Class B or A (Style Y or Z).

Applications

The FCM-1(A) is used to switch 24 VDC audible/visual power, high-level audio (speakers). The FRM-1(A) may be programmed to operate dry contacts for applications such as door holders or Air Handling Unit shutdown, and to reset four-wire smoke detector power.

NOTE: Refer to the SLC Manual (PN 51253) for details regarding releasing applications with the FCM-1(A). Refer to the FCM-1-REL datasheet (DN-60390) for new FlashScan® releasing applications.

Construction

- The face plate is made of off-white heat-resistant plastic.
- Controls include two rotary switches for direct-dial entry of address (01-159).

- The FCM-1(A) is configured for a single Class B (Style Y) or Class A (Style Z) Notification Appliance Circuit.
- The FRM-1(A) provides two Form-C dry contacts that switch together.

Operation

Each FCM-1(A) or FRM-1(A) uses one of 159 possible module addresses on a SLC loop (99 on CLIP loops). It responds to regular polls from the control panel and reports its type and status, including the open/normal/short status of its Notification Appliance Circuit (NAC). The LED blinks with each poll received. On command, it activates its internal relay. The FCM-1(A) supervises Class B (Style Y) or Class A (Style Z) notification or control circuits.

Upon code command from the panel, the FCM-1(A) will disconnect the supervision and connect the external power supply in the proper polarity across the load device. The disconnection of the supervision provides a positive indication to the panel that the control relay actually turned ON. The external power supply is always relay isolated from the communication loop so that a trouble condition on the external power supply will never interfere with the rest of the system.

Rotary switches set a unique address for each module. The address may be set before or after mounting. The built-in TYPE CODE (not settable) will identify the module to the control panel, so as to differentiate between a module and a sensor address.

Specifications for FCM-1(A)

Normal operating voltage: 15 to 32 VDC.

Maximum current draw: 6.5 mA (LED on).

Average operating current: 350 μ A direct poll, 375 μ A group poll with LED flashing, 485 μ A Max. (LED flashing, NAC shorted.)

Maximum NAC Line Loss: 4 VDC.

External supply voltage (between Terminals T10 and T11): Maximum (NAC): Regulated 24 VDC; Maximum (Speakers): 70.7 V RMS, 50W.

Drain on external supply: 1.7 mA maximum using 24 VDC supply; 2.2 mA Maximum using 80 VRMS supply.

Max NAC Current Ratings: For class B wiring system, the current rating is 3A; For class A wiring system, the current rating is 2A.

Temperature range: 32°F to 120°F (0°C to 49°C).

Humidity range: 10% to 93% non-condensing.

Dimensions: 4.5" (114.3 mm) high x 4" (101.6 mm) wide x 1.25" (31.75 mm) deep. Mounts to a 4" (101.6 mm) square x 2.125" (53.975 mm) deep box.

Accessories: SMB500 Electrical Box; CB500 Barrier

Specifications for FRM-1(A)

Normal operating voltage: 15 to 32 VDC.

Maximum current draw: 6.5 mA (LED on).

Average operating current: 230 µA direct poll; 255 µA group poll.

EOL resistance: not used.

Temperature range: 32°F to 120°F (0°C to 49°C).

Humidity range: 10% to 93% non-condensing.

Dimensions: 4.5" (114.3 mm) high x 4" (101.6 mm) wide x 1.25" (31.75 mm) deep. Mounts to a 4" (101.6 mm) square x 2.125" (53.975 mm) deep box.

Accessories: SMB500 Electrical Box; CB500 Barrier

Agency Listings and Approvals

In some cases, certain modules may not be listed by certain approval agencies, or listing may be in process. Consult factory for latest listing status.

- **UL:** S635
- **ULC:** S3705 (A version only)
- **FM Approved**
- **CSFM:** 7300-0028:0219
- **MEA:** 14-00-E
- **FDNY:** COA #6067, #6065

Contact Ratings for FRM-1(A)

Current Rating	Maximum Voltage	Load Description	Application
3 A	30 VDC	Resistive	Non-Coded
2 A	30 VDC	Resistive	Coded
.9 A	110 VDC	Resistive	Non-Coded
.9 A	125 VDC	Resistive	Non-Coded
.5 A	30 VDC	Inductive (L/R=5ms)	Coded
1 A	30 VDC	Inductive (L/R=2ms)	Coded
.3 A	125 VAC	Inductive (PF=0.35)	Non-Coded
1.5 A	25 VAC	Inductive (PF=0.35)	Non-Coded
.7 A	70.7 VAC	Inductive (PF=0.35)	Non-Coded
2 A	25 VAC	Inductive (PF=0.35)	Non-Coded

NOTE: Maximum (Speakers): 70.7 V RMS, 50 W

Product Line Information

NOTE: "A" suffix indicates ULC Listed model.

FCM-1(A): Intelligent Addressable Control Module.

FRM-1(A): Intelligent Addressable Relay Module.

A2143-20: Capacitor, required for Class A (Style Z) operation of speakers.

SMB500: Optional Surface-Mount Backbox.

CB500: Control Module Barrier — required by UL for separating power-limited and non-power limited wiring in the same junction box as FCM-1(A).

NOTE: For installation instructions, see the following documents:

- *FCM-1(A) Installation document I56-1169.*
- *FRM-1(A) Installation document I56-3502.*
- *Notifier SLC Wiring Manual, document 51253.*

Notifier® and FlashScan® are registered trademarks of Honeywell International Inc.

©2011 by Honeywell International Inc. All rights reserved. Unauthorized use of this document is strictly prohibited.



This document is not intended to be used for installation purposes. We try to keep our product information up-to-date and accurate. We cannot cover all specific applications or anticipate all requirements. All specifications are subject to change without notice.



Made in the U.S.A.

GRI

Tamper Switches

➤ GI-TS01

- *Screw terminals*

GI-TSW01

- *12" leads*
- Eliminates false alarms and service calls
- Fits most bell, siren, control panel mounting hole patterns
- Lifetime warranty



➤ NBG-12LX

Addressable Manual Pull Station



Intelligent/Addressable Devices

General

The Notifier NBG-12LX is a state-of-the-art, dual-action (i.e., requires two motions to activate the station) pull station that includes an addressable interface for any Notifier intelligent control panel except FireWarden series panels, and the NSP-25 panel. Because the NBG-12LX is addressable, the control panel can display the exact location of the activated manual station. This leads fire personnel quickly to the location of the alarm.

Features

- Maintenance personnel can open station for inspection and address setting without causing an alarm condition.
- Built-in bicolor LED, which is visible through the handle of the station, flashes in normal operation and latches steady red when in alarm.
- Handle latches in down position and the word “ACTIVATED” appears to clearly indicate the station has been operated.
- Captive screw terminals wire-ready for easy connection to SLC loop (accepts up to 12 AWG/3.25 mm² wire).
- Can be surface mounted (with SB-10 or SB-I/O) or semi-flush mounted. Semi-flush mount to a standard single-gang, double-gang, or 4" (10.16 cm) square electrical box.
- Smooth dual-action design.
- Meets ADAAG controls and operating mechanisms guidelines (Section 4.1.3[13]); meets ADA requirement for 5 lb. maximum activation force.
- Highly visible.
- Attractive shape and textured finish.
- Key reset.
- Includes Braille text on station handle.
- Optional trim ring (BG12TR).
- Meets UL 38, Standard for Manually Actuated Signaling Boxes.
- Up to 99 NBG-12LX stations per loop on CLIP protocol loops.
- Up to 159 NBG-12LX stations per loop on FlashScan® protocol loops.
- Dual-color LED blinks green to indicate normal on FlashScan® systems.

Construction

Shell, door, and handle are molded of durable polycarbonate material with a textured finish.

Specifications

- **Shipping Weight:** 9.6 oz. (272.15 g)
- **Normal operating voltage:** 24 VDC.
- **Maximum SLC loop voltage:** 28.0 VDC.
- **Maximum SLC loop current:** 375 µA.
- **Temperature Range:** 32°F to 120°F (0°C to 49°C)
- **Relative Humidity:** 10% to 93% (noncondensing)
- **For use indoors in a dry location**



The NBG-12LX
Addressable Manual Pull Station

Installation

The NBG-12LX will mount semi-flush into a single-gang, double-gang, or standard 4" (10.16 cm) square electrical outlet box, or will surface mount to the model SB-10 or SB-I/O surface backbox. If the NBG-12LX is being semi-flush mounted, then the optional trim ring (BG12TR) may be used. The BG12TR is usually needed for semi-flush mounting with 4" (10.16 cm) or double-gang boxes (not with single-gang boxes).

Operation

Pushing in, then pulling down on the handle causes it to latch in the down/activated position. Once latched, the word “ACTIVATED” (in bright yellow) appears at the top of the handle, while a portion of the handle protrudes from the bottom of the station. To reset the station, simply unlock the station with the key and pull the door open. This action resets the handle; closing the door automatically resets the switch.

Each manual station, on command from the control panel, sends data to the panel representing the state of the manual switch. Two rotary decimal switches allow address settings (1 – 159 on FlashScan® systems, 1 – 99 on CLIP systems).

Architectural/Engineering Specifications

Manual Fire Alarm Stations shall be non-coded, with a key-operated reset lock in order that they may be tested, and so designed that after actual Emergency Operation, they cannot be restored to normal except by use of a key. An operated station shall automatically condition itself so as to be visually detected as activated. Manual stations shall be constructed of red-colored polycarbonate material with clearly visible operating instructions provided on the cover. The word FIRE shall appear on the front of the stations in white letters, 1.00 inches (2.54 cm) or larger. Stations shall be suitable for surface mounting on matching backbox SB-10 or SB-I/O; or semi-flush mounting on a standard single-gang, double-gang, or 4"

(10.16 cm) square electrical box, and shall be installed within the limits defined by the Americans with Disabilities Act (ADA) or per national/local requirements. Manual Stations shall be Underwriters Laboratories listed.

Manual stations shall connect with two wires to one of the control panel SLC loops. The manual station shall, on command from the control panel, send data to the panel representing the state of the manual switch. Manual stations shall provide address setting by use of rotary decimal switches.

The loop poll LED shall be clearly visible through the front of the station. The LED shall flash while in the normal condition, and stay steadily illuminated when in alarm.

Product Line Information

➤ **NBG-12LX:** Dual-action addressable pull station. Includes key locking feature.

SB-10: Surface backbox; metal.

SB-I/O: Surface backbox; plastic.

BG12TR: Optional trim ring.

17021: Keys, set of two.

NY-Plate: New York City trim plate

Agency Listings and Approvals

In some cases, certain modules or applications may not be listed by certain approval agencies, or listing may be in process. Consult factory for latest listing status.

- **UL / CUL Listed:** S692 (listed for Canadian and non-Canadian applications)
- **MEA:** 67-02-E
- **CSFM:** 7150-0028:0199
- **FDNY:** COA #6038 (NFS2-640), COA #6058 (NFS2-3030)
- **BSMI:** CI313066760047
- **U.S. Coast Guard:** 161.002/23/3 (AFP-200); 161.002/27/3 (AM-2020/AFP-1010; 161.002/42/1 (NFS-640)
- **Lloyd's Register:** 02/6007 (NFS-640); 94/60004 (E2) (AFP-200); 03/60011 (E1); 07/60007 (NFS2-3030)
- **FM Approved**

Patented: U.S. Patent No. D428,351; 6,380,846; 6,314,772; 6,632,108.

Notifier® and FlashScan® are a registered trademarks of Honeywell International Inc.
©2010 by Honeywell International Inc. All rights reserved. Unauthorized use of this document is strictly prohibited.



This document is not intended to be used for installation purposes.
We try to keep our product information up-to-date and accurate.
We cannot cover all specific applications or anticipate all requirements.
All specifications are subject to change without notice.



Total Current	
C1	0.404 A
C2	2.879 A
C3	0.444 A
C4	2.879 A

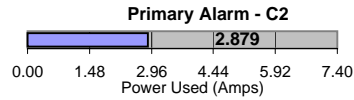
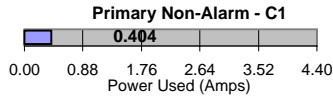

Device	C1 - Primary Non-Alarm			C2 - Primary Alarm			C3 - Secondary Non-Alarm				
	Qty	Draw	Total	Qty	Draw	Total	Qty	Draw	Total		
CPU2-640	1	x 0.25000	0.25000	1	x 0.25000	0.25000	1	x 0.25000	0.25000		
CPS-24	1	x 0.00000	0.00000	1	x 0.00000	0.00000	1	x 0.04000	0.04000		
NCM-W, NCM-F	1	x 0.11000	0.11000	1	x 0.11000	0.11000	1	x 0.11000	0.11000		
UDACT Communicator	1	x 0.04000	0.04000	1	x 0.10000	0.10000	1	x 0.04000	0.04000		
FMM-1	5	x 0.00030	0.00150				5	x 0.00030	0.00150		
FRM-1	3	x 0.00020	0.00060				3	x 0.00020	0.00060		
NBG-12LX	4	x 0.00030	0.00120				4	x 0.00030	0.00120		
FSP-851	1	x 0.00036	0.00036				1	x 0.00036	0.00036		
SLC Loop Device Activation Current				1	x 0.40000	0.40000					
HSR15	10	x 0.00000	0.00000	10	x 0.08200	0.82000	10	x 0.00000	0.00000		
STR15	7	x 0.00000	0.00000	7	x 0.05700	0.39900	7	x 0.00000	0.00000		
Flashing Beacon	1	x 0.00000	0.00000	1	x 0.80000	0.80000	1	x 0.00000	0.00000		
Total Non-Alarm Load:			0.404	Total Alarm Load:			2.879	Total Standby Load:			0.444

C4 - Maximum Secondary Fire Alarm Current Draw

Only include those additional power supplies that are backed up by the control panels batteries.

Device	Qty	Draw	Total
Total Primary Alarm Load - C2		2.879	2.879
APS-6R	0	x 6.000	
APS2-6R	0	x 6.000	
ACPS-610	0	x 10.000	
FCPS-24S6	0	x 6.000	
FCPS-24S8	0	x 8.000	
HPFF8	0	x 8.000	
HPFF12	0	x 12.000	
DAA2 Series		0.000	
DAX Series		0.000	
DAA Series		0.000	
FireVoice Panels		0.000	
FireVoice Distributed Audio Panels		0.000	
XPIQ		0.000	
AA-30	0	x 3.000	
AA-120	0	x 7.300	
Other Power Supply	0	x 0.000	
Other Power Supply	0	x 0.000	
Total Standby Alarm Load:			2.879



System Power Requirements

Notifier NFS2-640 Fire Alarm Control Panel

Protected Premises: <u>USM 25 Bedford Street</u>		Date: <u>6/5/2012</u>
Address: <u>25 Bedford Street</u>		
City: <u>Portland</u>	State: <u>Maine</u>	Zip: _____
Prepared By: <u>Norris Inc.</u>		Phone: _____
Address: <u>2257 West Broadway</u>		Email: _____
City: <u>South Portland</u>	State: <u>Maine</u>	Zip: <u>04106</u>

AC Branch Current Requirements 5.00 AMPS @ 120 VAC

Current required by source to power the fire alarm system.

Primary Standby Load 0.40 Amps

Current load on the primary power supply during non-alarm conditions.

Primary Alarm Load 2.88 Amps

Current load on the primary power supply during alarm conditions.

Secondary Load Requirements 13.64 Amp Hours

Total Secondary Load from the calculation table below.

Current Draw		Time (hours)	Total (AH)
Secondary Standby Load 0.444 A	x	Required Standby Time	
		24 hours	10.65
Secondary Alarm Load 2.879 A	x	Required Alarm Time	
		0.250 hours	0.72
Total Secondary Load			11.37
Derating factor			x 1.2
Secondary Load Requirements (Amp Hours)			13.64 AH

Battery Selection 18 Amp Hours

Select batteries from the list below.

18 AH BAT-12180 Battery (12 volt)

- Two
 Four (two 12VDC sets in parallel)

Battery Distribution Chart

Shows amp-hour distribution of your selections.

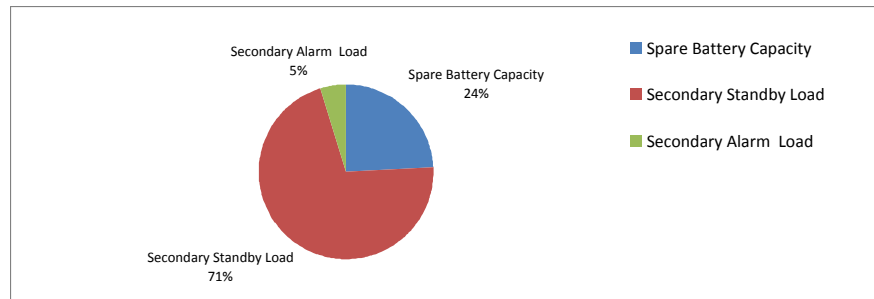

Comments

- Batteries will fit in the FACP cabinet.
- Selected battery size meets secondary load requirements.
- The selected batteries (18AH) are within the charger range of this power supply (18-200AH).

Spare Battery Capacity	4.36	Battery Selection (AH) - Secondary Load Requirements (AH)
Secondary Standby Load	12.78	Secondary Standby Load (AH) * Derating Factor
Secondary Alarm Load	0.86	Secondary Alarm Load (AH) * Derating Factor

Important! Wiring connections must have correct polarity.

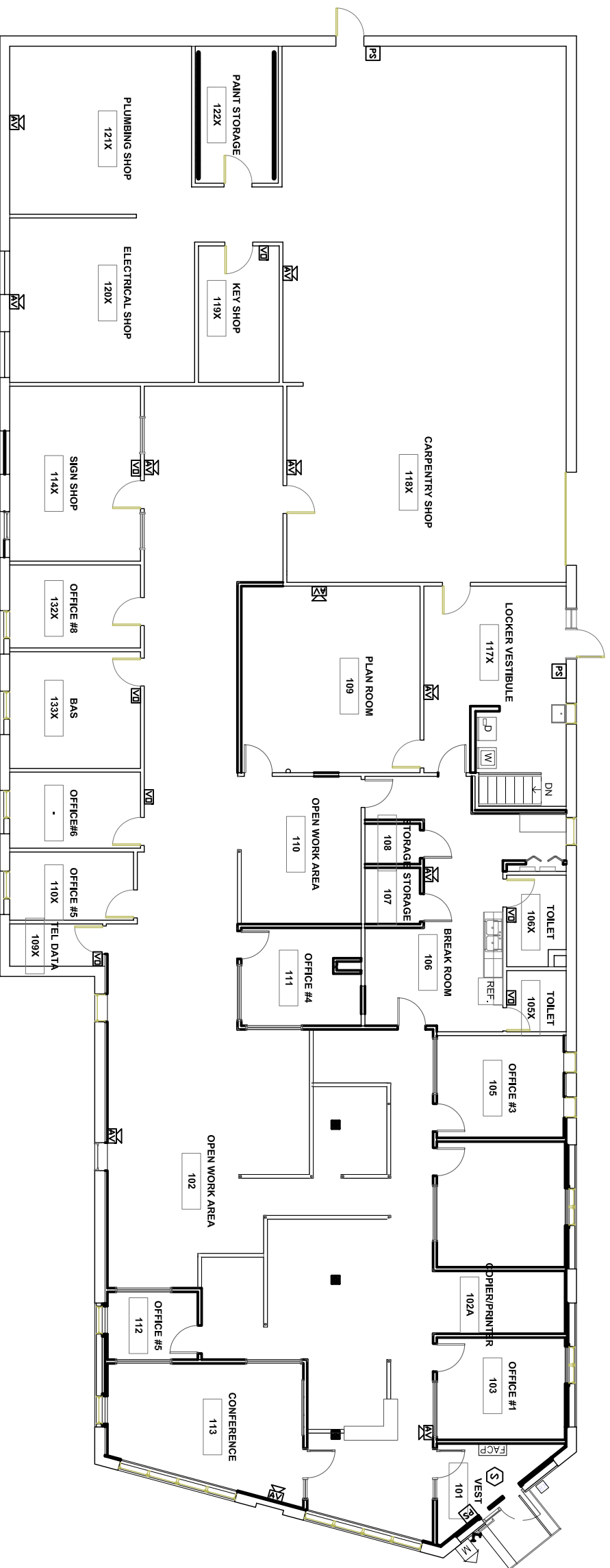
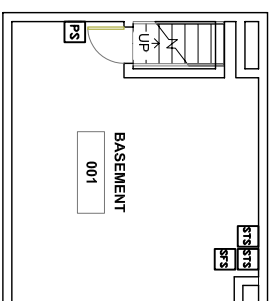

LEGEND

- 48 INCHES **PS** PULL STATION
- 80 INCHES **S** SMOKE DETECTOR
- 80 INCHES **R** HEAT DETECTOR RATE OF RISE
- 80 INCHES **F** HEAT DETECTOR FIXED TEMP
- RT** REMOTE TEST/INDICATOR
- DS** DUCT SMOKE DETECTOR W/ FSP-851R HEAD
- VD** VISUAL ONLY
- 80 INCHES **AV** AUDIO / VISUAL
- DSM** DUAL SYNC MODULE
- ISD** ISOLATION MODULE
- FMM** MONITOR MODULE
- FRM** RELAY MODULE
- STS** SPRINKLER TAMPER
- SFS** SPRINKLER FLOW

This drawing is an accurate layout from provided floor plans and information available at time of design. Circulating has been designed for maximum use of resources available with supplied equipment. Deviations from this design must be noted and approved prior to final acceptance. Note Signal Circuit 1 has a 2.5 amp load limitation, Circuits 2-3-4 have a combined load limitation of 2.5 amps. REMOTE power supply has a 3.0 amps limitation per circuit and an 8.0 amp combined limitation for all 4 circuits. Changes in circuiting must incorporate equipment specifications/limitations (see chart below for current vs. candle rating. Distances and ratings shown are for wall applications ONLY, call Norris, Inc. for ceiling devices when applicable.) Twisted-Shielded Cable is NOT recommended for use on SLC wiring for this panel. Untwisted cable inside/outside conduit has a 100' max distance sizes 12-18AWG.

Room Size	Candela Rating	Load (amps)
20' x 20'	15 cd	0.08 amps
28' x 28'	30 cd	0.10 amps
45' x 45'	75 cd	0.15 amps
54' x 54'	110 cd	0.20 amps

- 4.7k END OF LINE RESISTOR (Panel Circuits)
- A 1 PR #12 AVG TWISTED PAIR CABLE(Up to 10,000 ft)
 - A 1 PR #14 AVG TWISTED PAIR CABLE(Up to 8,000 ft)
 - A 1 PR #16 AVG TWISTED PAIR CABLE(Up to 4,500 ft)
 - B 1 PR #12 AVG FPL CABLE
 - D 1 PR #14 AVG FPL CABLE
 - E 1 PR #16 AVG FPL CABLE
 - F 2c #12 AVG CABLE
 - G 2c #14 AVG CABLE
 - H 2c #16 AVG CABLE
 - K 1 CAT5 CABLE
 - L 1 PR #16 AVG TWISTED SHIELDED CABLE

REVISION	DATE
REVISION 2	DATE:
REVISION 1	DATE:
REVISION 0 SUBMITTAL	DATE: 6/5/2012

PROJECT NAME
USM (25 BEDFORD STREET)

SCALE NTS
BY: CIC
CK BY:

SAVED AS:

Important! Duplicate Addresses on devices of different style is NOT an error in design or printing. All electronic devices MUST be placed in a heated room with temperature above 32 degrees

Important! Wiring connections must have correct polarity.

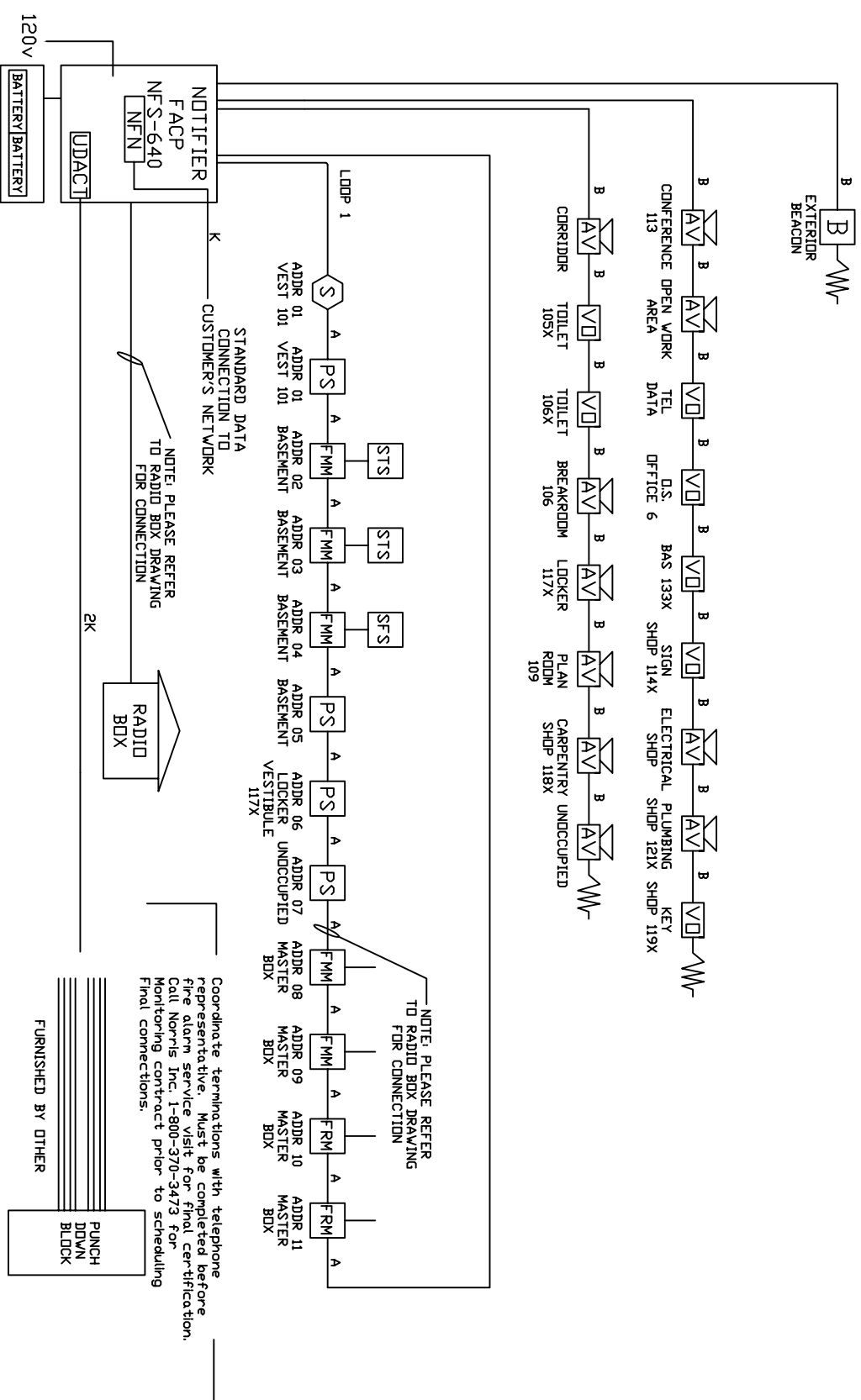

LEGEND

- PS 48 INCHES MOUNTING HEIGHT PULL STATION
- S SMOKE DETECTOR
- R HEAT DETECTOR RATE OF RISE
- F HEAT DETECTOR FIXED TEMP
- RT REMOTE TEST/INDICATOR
- DS DUCT SMOKE DETECTOR W/ FSP-85IR HEAD
- VO 80 INCHES VISUAL ONLY
- AV 80 INCHES AUDIO / VISUAL
- B FLASHING RED BEACON
- ISD ISOLATION MODULE
- FMM MONITOR MODULE
- FRM RELAY MODULE
- STS SPRINKLER TAMPER
- SFS SPRINKLER FLOW

This drawing is an accurate layout from provided floor plans and information available at time of design. Circuiting has been designed for maximum use of resources available with supplied equipment. Deviations from this design must be noted and approved prior to final acceptance. Note Signal Circuit 1 has a 2.5 amp load limitation, Circuits 2-3-4 have a combined load limitation of 2.5 amps. REMOTE power supply has a 3.0 amp limitation per circuit and an 8.0 amp combined limitation for all 4 circuits. Changes in circuiting must incorporate equipment specifications/limitations (see chart below for current vs. candela rating. Distances and ratings shown are for wall applications ONLY, call Norris, Inc. for ceiling devices when applicable.) Twisted-Shielded Cable is NOT recommended for use on SLC wiring for this panel. Untwisted cable inside/outside conduit has a 100' max distance sizes 12-18AWG.

Room Size	Candela Rating	Load (amps)
20' x 20'	15 cd	0.08 amps
28' x 28'	30 cd	0.10 amps
45' x 45'	75 cd	0.15 amps
54' x 54'	110 cd	0.20 amps

- 4.7k END OF LINE RESISTOR (Panel Circuits)
- A 1 PR #12 AVG TWISTED PAIR CABLE(Up to 10,000 ft)
 - A 1 PR #14 AVG TWISTED PAIR CABLE(Up to 8,000 ft)
 - A 1 PR #16 AVG TWISTED PAIR CABLE(Up to 4,500 ft)
 - B 1 PR #12 AVG FPL CABLE
 - D 1 PR #14 AVG FPL CABLE
 - E 1 PR #16 AVG FPL CABLE
 - F 2c #12 AVG CABLE
 - G 2c #14 AVG CABLE
 - H 2c #16 AVG CABLE
 - K 1 CAT5 CABLE
 - L 1 PR #16 AVG TWISTED SHIELDED CABLE

REVISION	DATE
REVISION 2	DATE:
REVISION 1	DATE:
REVISION 0	DATE: 6/5/2012

SYSTEM WIRING RISER

PROJECT NAME
USM (25 BEDFORD STREET)

SCALE NTS
BY: CIC
CK BY:
SAVED AS:

Prepared For Tomorrow, Delivered Today
NORRIS INC
2257 BRADDAWAY, SO PORTLAND, MAINE

Important! Duplicate Addresses on devices of different style is NOT an error in design or printing. All electronic devices MUST be placed in a heated room with temperature above 32 degrees

This drawing is a typical set up for a AES box that only requires one zone.

SYMBOL LEGEND

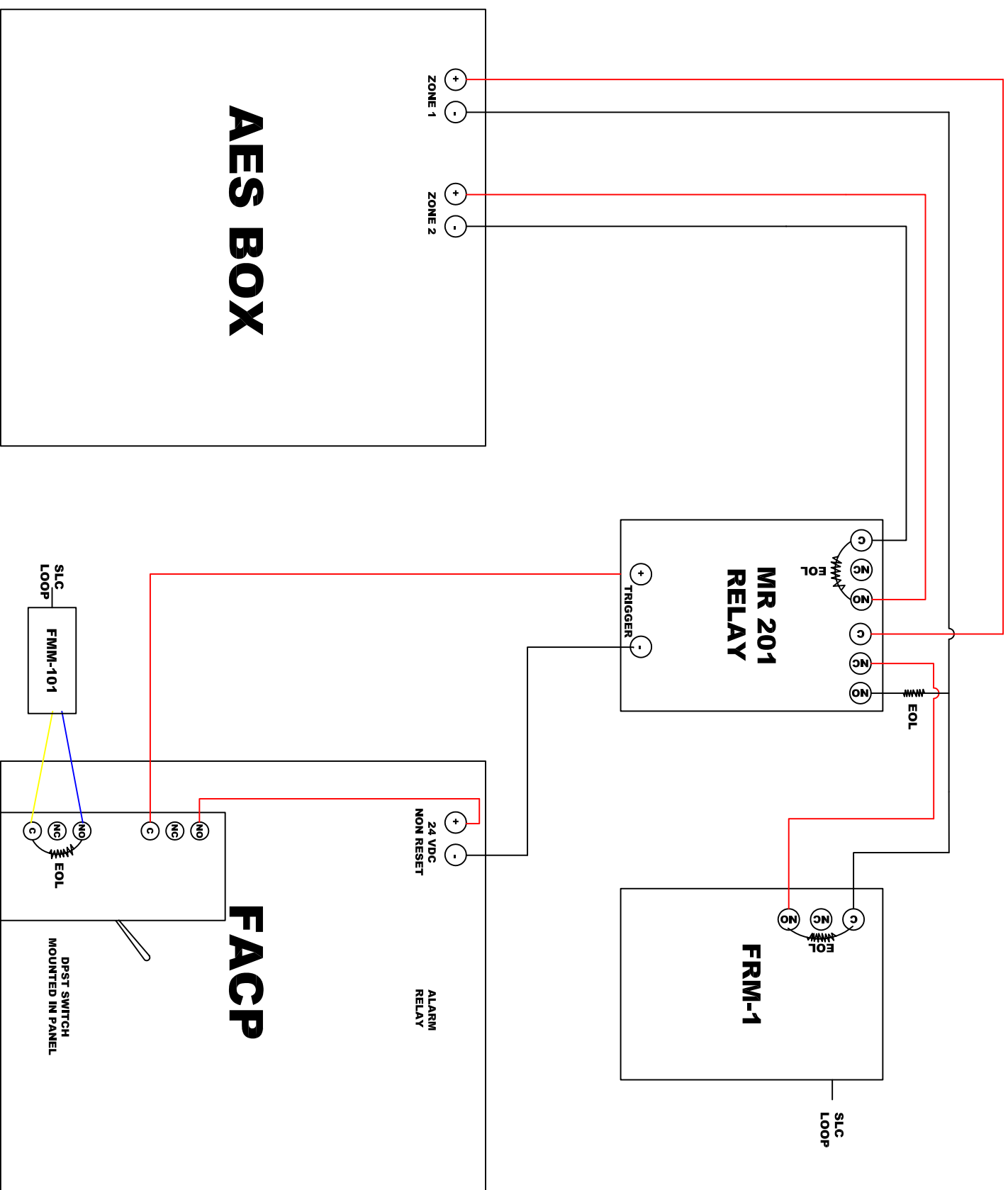

REVISION 2	DATE:
REVISION 1	DATE:
REVISION 0	DATE: 6-05-2012

SYSTEM WIRING RISER

PROJECT NAME
USM (25 Bedford Street)
 Portland, MAINE

SCALE NTS
 BY: **gjc**
 CK BY:
 SAVED AS:

NORRIS INC
 Prepared for tomorrow. Delivered Today.
 2257 BROADWAY, SOUTH PORTLAND, MAINE

REVISION 2 DATE:

REVISION 1 DATE:

REVISION 0 SUBMITTAL DATE: 06/5/12

SYSTEM WIRING RISER

PROJECT NAME

USM (25 BEDFORD STREET)

SCALE: NTS

BY: CJC

CK BY:



Prepared for Tomorrow. Delivered Today

2257 W BROADWAY, SO PORTLAND, MAINE 04106

SAVED AS:

		CONTROL UNIT ACTIVATION								NOTIFICATION							REQUIRED FIRE SAFETY CONTROL																								
		A	B	C	D	E	F	G	H	I	J	K	L	M	N	O	P	Q	U	V	1	2	3	4	5	6	7	8	9	10	11	12	13	14	15	16	17	18	19	20	21
1	MANUAL FIRE ALARM PULL STATION	●	●					●	●	●	●	●		●							1	2	3	4	5	6	7	8	9	10	11	12	13	14	15	16	17	18	19	20	21
2	AREA SMOKE DETECTOR	●	●					●	●	●	●	●		●							2	3	4	5	6	7	8	9	10	11	12	13	14	15	16	17	18	19	20	21	
3	SPRINKLER WATERFLOW	●	●					●	●	●	●	●		●							3	4	5	6	7	8	9	10	11	12	13	14	15	16	17	18	19	20	21		
4	SPRINKLER TAMPER SWITCH			●	●			●	●				●								4	5	6	7	8	9	10	11	12	13	14	15	16	17	18	19	20	21			
5	FIRE ALARM AC POWER FAILURE					●	●	●	●				●								5	6	7	8	9	10	11	12	13	14	15	16	17	18	19	20	21				
6	FIRE ALARM SYSTEM LOW BATTERY					●	●	●	●				●								6	7	8	9	10	11	12	13	14	15	16	17	18	19	20	21					
7	OPEN CIRCUIT					●	●	●	●				●								7	8	9	10	11	12	13	14	15	16	17	18	19	20	21						
8	GROUND FAULT					●	●	●	●				●								8	9	10	11	12	13	14	15	16	17	18	19	20	21							
9	NOTIFICATION APPLIANCE CIRCUIT SHORT					●	●	●	●				●								9	10	11	12	13	14	15	16	17	18	19	20	21								
10																					10	11	12	13	14	15	16	17	18	19	20	21									
11																					11	12	13	14	15	16	17	18	19	20	21										
12																					12	13	14	15	16	17	18	19	20	21											
13																					13	14	15	16	17	18	19	20	21												
14																					14	15	16	17	18	19	20	21													
15																					15	16	17	18	19	20	21														
16																					16	17	18	19	20	21															
17																					17	18	19	20	21																
18																					18	19	20	21																	
19																					19	20	21																		
20																					20	21																			
21																					21																				

This
Certificate of Fitness

**MASTER
Fire Alarm Installation and Servicing Company**

is awarded to

NORRIS INC.

PO Box 2551 – 2257 West Broadway
S. Portland, ME 04106
(207)883-3473

CF # **M1008**



B. Jaworski

Authority Having Jurisdiction

12/31/2011

Expiration Date

**THIS CERTIFICATE IS NOT AN ENDORSEMENT OF THIS COMPANY BY THE
AUTHORITY HAVING JURISDICTION.**

**TERMS AND CONDITIONS OF THIS CERTIFICATE OF FITNESS SHALL BE AS
FOLLOWS:**

**THIS CERTIFICATE REMAINS THE PROPERTY OF THE PORTLAND FIRE
DEPARTMENT AND SHALL BE RETURNED UPON DEMAND;**

THIS CERTIFICATE OF FITNESS IS NON-TRANSFERABLE;

**THIS CERTIFICATE OF FITNESS SHALL REMAIN IN EFFECT IN SO FAR AS THE
BEARER OF SAID INSTRUMENT SHALL COMPLY WITH RULES AND
REGULATIONS ESTABLISHED BY THE AUTHORITY HAVING JURISDICTION.**

**FAILURE TO COMPLY WITH ALL RULES AND REGULATIONS OF THE
AUTHORITY HAVING JURISDICTION WILL RESULT IN THE FOLLOWING:**

FIRST OFFENCE: PLAN OF ACTION TO ADDRESS DEFICIENCIES

SECOND OFFENCE: PROBATION OF SERVICE COMPANY

THIRD OFFENCE: TERMINATION OF CERTIFICATE OF FITNESS