

**City of Portland, Maine - Building or Use Permit Application**

389 Congress Street, 04101 Tel: (207) 874-8703, Fax: (207) 874-8716

Permit No: 04-1211	Issue Date:	CBL: 296 D002001
-----------------------	-------------	---------------------

Location of Construction: 314 Warren Ave	Owner Name: Baker Dwight P	Owner Address: 336 Warren Ave	Phone:
Business Name:	Contractor Name: Steve Mackensie	Contractor Address: 74 Gertrude Portland	Phone 2077977706
Lessee/Buyer's Name	Phone:	Permit Type: HVAC	Zone: B-4
Past Use: Commercial	Proposed Use: Commercial- Install Airco metal Chimney	Permit Fee: \$66.00	Cost of Work: \$4,500.00
		CEO District: 5	
		FIRE DEPT: <input checked="" type="checkbox"/> Approved <input type="checkbox"/> Denied	INSPECTION: Use Group: HEATING Type: 9/1/04
		Signature: <i>[Signature]</i>	Signature: <i>[Signature]</i>
		PEDESTRIAN ACTIVITIES DISTRICT (P.A.D.)	
		Action: <input type="checkbox"/> Approved <input type="checkbox"/> Approved w/Conditions <input type="checkbox"/> Denied	
		Signature:	Date:

Permit Taken By: Idobson	Date Applied For: 08/18/2004	<b>Zoning Approval</b>
-----------------------------	---------------------------------	------------------------

<p>1. This permit application does not preclude the Applicant(s) from meeting applicable State and Federal Rules.</p> <p>2. Building permits do not include plumbing, septic or electrical work.</p> <p>3. Building permits are void if work is not started within six (6) months of the date of issuance. False information may invalidate a building permit and stop all work..</p>	<p><b>Special Zone or Reviews</b></p> <p><input type="checkbox"/> Shoreland</p> <p><input type="checkbox"/> Wetland</p> <p><input type="checkbox"/> Flood Zone</p> <p><input type="checkbox"/> Subdivision</p> <p><input type="checkbox"/> Site Plan</p> <p>Maj <input type="checkbox"/> Minor <input type="checkbox"/> MM <input type="checkbox"/></p> <p>Date: <i>OK 8/19/04</i></p>	<p><b>Zoning Appeal</b></p> <p><input type="checkbox"/> Variance</p> <p><input type="checkbox"/> Miscellaneous</p> <p><input type="checkbox"/> Conditional Use</p> <p><input type="checkbox"/> Interpretation</p> <p><input type="checkbox"/> Approved</p> <p><input type="checkbox"/> Denied</p> <p>Date:</p>	<p><b>Historic Preservation</b></p> <p><input checked="" type="checkbox"/> Not in District or Landmark</p> <p><input type="checkbox"/> Does Not Require Review</p> <p><input type="checkbox"/> Requires Review</p> <p><input type="checkbox"/> Approved</p> <p><input type="checkbox"/> Approved w/Conditions</p> <p><input type="checkbox"/> Denied</p> <p>Date: <i>[Signature]</i></p>
---	--	--	--

**CERTIFICATION**

I hereby certify that I am the owner of record of the named property, or that the proposed work is authorized by the owner of record and that I have been authorized by the owner to make this application as his authorized agent and I agree to conform to all applicable laws of this jurisdiction. In addition, if a permit for work described in the application is issued, I certify that the code official's authorized representative shall have the authority to enter all areas covered by such permit at any reasonable hour to enforce the provision of the code(s) applicable to such permit.

SIGNATURE OF APPLICANT	ADDRESS	DATE	PHONE
RESPONSIBLE PERSON IN CHARGE OF WORK, TITLE		DATE	PHONE

**City of Portland, Maine - Building or Use Permit**

389 Congress Street, 04101 Tel: (207) 874-8703, Fax: (207) 874-8716

<b>Permit No:</b> 04-1211	<b>Date Applied For:</b> 08/18/2004	<b>CBL:</b> 296 D002001
------------------------------	--	----------------------------

<b>Location of Construction:</b> 314 Warren Ave	<b>Owner Name:</b> Baker Dwight P	<b>Owner Address:</b> 336 Warren Ave	<b>Phone:</b>
<b>Business Name:</b>	<b>Contractor Name:</b> Steve Mackensie	<b>Contractor Address:</b> 74 Gertrude Portland	<b>Phone:</b> (207) 797-7706
<b>Lessee/Buyer's Name</b>	<b>Phone:</b>	<b>Permit Type:</b> HVAC	

<b>Proposed Use:</b> Commercial- Install Airco metal Chimney	<b>Proposed Project Description:</b> Install Airco metal Chimney
---	---

<b>Dept:</b> Zoning	<b>Status:</b> Approved	<b>Reviewer:</b> Marge Schmuckal	<b>Approval Date:</b> 08/19/2004	<b>Note:</b>	<b>Ok to Issue:</b> <input checked="" type="checkbox"/>
<b>Dept:</b> Building	<b>Status:</b> Approved with Conditions	<b>Reviewer:</b> Mike Nugent	<b>Approval Date:</b> 09/01/2004	<b>Note:</b>	<b>Ok to Issue:</b> <input checked="" type="checkbox"/>
<b>Dept:</b> Fire	<b>Status:</b> Approved with Conditions	<b>Reviewer:</b> Lt. MacDougal	<b>Approval Date:</b> 08/30/2004	<b>Note:</b>	<b>Ok to Issue:</b> <input checked="" type="checkbox"/>

f) the chimney shall be installed in accordance with the manufacturers recommendations



FILL IN AND SIGN WITH INK

296 8002

# APPLICATION FOR PERMIT HEATING OR POWER EQUIPMENT

To the INSPECTOR OF BUILDINGS, PORTLAND, ME.

The undersigned hereby applies for a permit to install the following heating, cooking or power equipment in accordance with the Laws of Maine, the Building Code of the City of Portland, and the following specifications:

Location / CBL 314 WARREN AVE REAR Use of Building COM. Date 8/9/04  
Name and address of owner of appliance SKIP BAKER

Installer's name and address Steve Mackenzie Hastings  
74 Gertrude Ave Foot Hill Telephone \_\_\_\_\_

### Location of appliance:

- Basement
- Attic
- Floor
- Roof

### Type of Fuel:

- Gas
- Oil
- Solid

Appliance Name: AIRCO (Chimney)

U.L. Approved  Yes  No

Will appliance be installed in accordance with the manufacture's installation instructions?  Yes  No

IF NO Explain: \_\_\_\_\_

### The Type of License of Installer:

- Master Plumber # \_\_\_\_\_
- Solid Fuel # \_\_\_\_\_
- Oil # 1340
- Gas # \_\_\_\_\_
- Other \_\_\_\_\_

### Type of Chimney:

- Masonry Lined  
Factory built \_\_\_\_\_
- Metal  
Factory Built U.L. Listing # \_\_\_\_\_
- Direct Vent  
Type \_\_\_\_\_ UL# \_\_\_\_\_

### Type of Fuel Tank

- Oil
- Gas

Size of Tank 330

Number of Tanks 1

Distance from Tank to Center of Flame 20' feet.

Cost of Work: \$ 4500.00

Permit Fee: \$ 660.00

### Approved

Fire: AM  
Ele.: \_\_\_\_\_  
Bldg.: AM

### Approved with Conditions

- See attached letter or requirement

Signature of Installer

Steve Mackenzie Hastings

Inspector's Signature

Date Approved

White - Inspection    Yellow - File    Pink - Applicant's    Gold - Assessor's Copy

CHK#511



LIMITED LIFETIME WARRANTY: Selkirk LLC ("Selkirk", "we", "us", "our") warrants to the original purchaser/consumer that Metalbestos Model; UT, GT & ST Type HT Chimney, DT Direct Vent, DS, VP, Type B Gas Vent, AFCL, SFCL, DWC and SWC products are to be free from defects in material and workmanship for the life of the product when properly connected to an applicable appliance listed by an accredited safety certification agency and installed in accordance with our installation instructions and specifications.

- ^ For products installed after January 1, 2000, for a period of Ten (10) years from original installation, we will provide replacement product to the original consumer for the product proven defective with a similar or like quantity of available Selkirk LLC product, free of charge.
^ From the Eleventh (11) through Fifteenth (15) years we will provide replacement product to the original consumer at a cost of 75% off of the published Retail Price in effect on the date the claim is received.
^ At expiration of the Fifteen (15) year term, we will provide replacement product to the original consumer at a cost of 50% off of the published Retail Price in effect on the date the claim is received.

WARNING: FAILURE TO INSTALL SELKIRK PRODUCTS ACCORDING TO THE MANUFACTURER'S INSTRUCTIONS WILL VOID ALL APPLICABLE WARRANTIES AND MAY RESULT IN FIRE, CARBON MONOXIDE POISONING OR DEATH. SEE OUR SELKIRK LLC PRODUCTS INSTALLATION INSTRUCTIONS FOR COMPLETE INSTRUCTIONS. Call 800-992-8368 for a free copy. WE DO NOT GUARANTEE OR IN ANY WAY WARRANT THE INSTALLATION OF SELKIRK PRODUCTS DUE TO THE WIDE VARIANCE IN INSTALLATION PRACTICES AND OTHER CONDITIONS BEYOND OUR CONTROL.

THIS LIMITED WARRANTY DOES NOT COVER:

- (a) costs (labor or otherwise) associated with either removing a previously installed product, installing a replacement product, transportation or return of a product, or transportation of replacement product;
(b) damage to the finish of products caused by the use of improper solvents/chemicals or improper cleaning methods;
(c) damage resulting from failure to reasonably clean, care for or maintain products in accordance with our installation instructions/recommendations;
(d) damage (to products, appliance or structure) based on or resulting from improper installation or repair, misuse or abuse (including, but not limited to, excessive improper operating condition), or alteration or adjustments other than in conformity with our installation instructions and specifications whether performed by a contractor, service company, technician, or yourself;
(e) any products that have been moved from their original installation site;
(f) damage resulting when driftwood/garbage, or any other prohibitive material has been burned in the appliance served by the chimney;
(g) damage to your chimney that results from accidents such as fire, flood, high winds, "acts of God", or any other contingency beyond our control.

CLAIM PROCEDURE: If you believe that a product fails to meet the above limited warranty, notify us in writing at the following location:

SELKIRK LLC Attn: WARRANTY CLAIMS DEPARTMENT
14801 Quorum Drive, Dallas, TX 75254
Fax: (877) 393-4145 Ph: (800) 992-8368

Notification should include a description of the product, model and part number and how the product fails to meet the above warranty. Upon receipt of a written claim under this limited warranty and evidence of the date of purchase or installation, at our option and in our sole discretion, we will either repair or replace product with similar or like quantity of available Selkirk LLC product per this warranty. Selkirk LLC reserves the right to inspect or investigate any warranty claims prior to determining whether to repair or replace a product. If, as determined by Selkirk LLC repair or replacement of the product is not commercially practicable or cannot be completed in a timely manner, we may refund the prorated purchase price paid for the product upon verification by providing a copy of your invoice, receipt of bill of sale.

ANY IMPLIED WARRANTY OF MERCHANTABILITY OR FITNESS FOR A PARTICULAR PURPOSE IS LIMITED IN DURATION TO THE WARRANTY PERIOD SPECIFIED ABOVE. WE DISCLAIM ANY LIABILITY FOR CONSEQUENTIAL OR INCIDENTAL DAMAGES AND ANY LOSS OR EXPENSES(S), NOT SPECIFIED ABOVE. SOME STATES MAY NOT ALLOW THE EXCLUSION OR LIMITATION OF INCIDENTAL OR CONSEQUENTIAL DAMAGES, OR HOW LONG AN IMPLIED WARRANTY LASTS, SO THE ABOVE EXCLUSIONS OR LIMITATIONS MAY NOT APPLY TO YOU. THIS WARRANTY GIVES YOU SPECIFIC LEGAL RIGHTS AND YOU MAY ALSO HAVE LEGAL RIGHTS WHICH VARY FROM STATE TO STATE.

Please register your warranty on our web site at w.selkirkin.com

# A T T E N T I O N

"We've made going thru the ceiling even safer."

Use our **NEW** redesigned Attic Insulation Shield to make your installation quick, easy, and the safest on the market. No assembly needed with this one piece design which is completely enclosed to eliminate material from falling into the shielded area. Order today by calling 800.992.8368 or log on to [www.selkirkinc.com](http://www.selkirkinc.com).

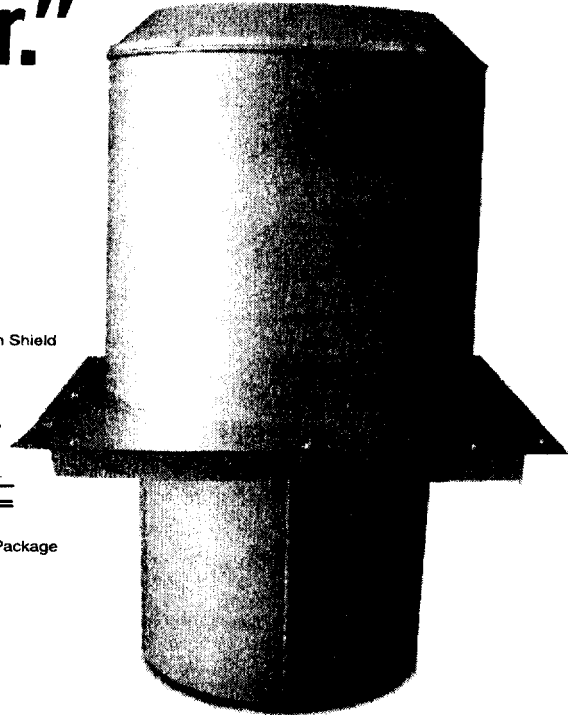
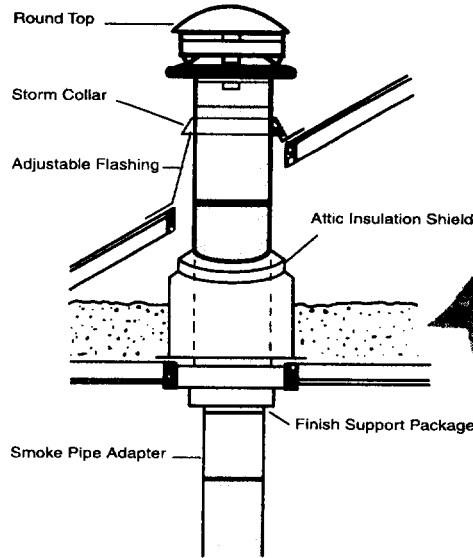

"We've made going thru the wall even easier."

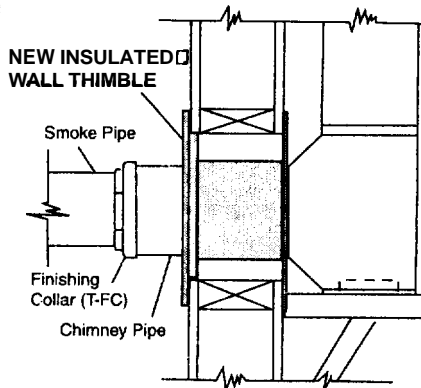
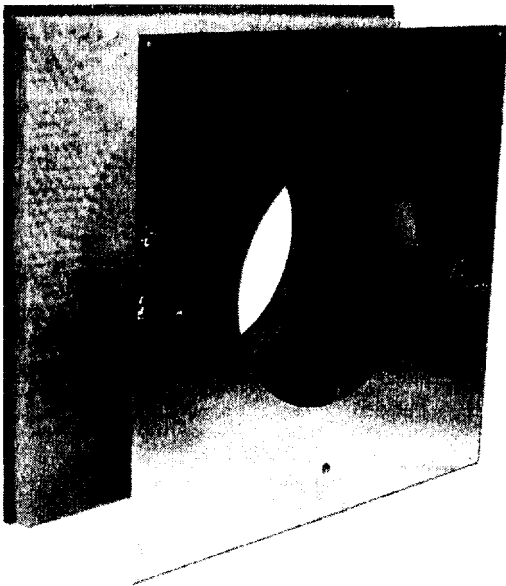

Insulated Wall Thimble keeps out the draft so you don't have to

Use our **NEW** Insulated Wall Thimble to make your installation quick and easy. The IWT eliminates the need to box in and insulate the wall opening, and is telescopic, so it adjusts to different wall thicknesses. An Alternative to using our TCS - Fire Stop/Trim Collar and WS - Fire Stop/Wall Spacer. Order today by calling 800.992.8368 or log on to [www.selkirkinc.com](http://www.selkirkinc.com).



**SELKIRK.**

UNITED STATES • CANADA • MEXICO

Model SSII Chim

