

J1 WINDOW HEAD DETAIL @ ALUMINUM FRAME IN 1HR RATED WALL
1/12" = 1'-0"

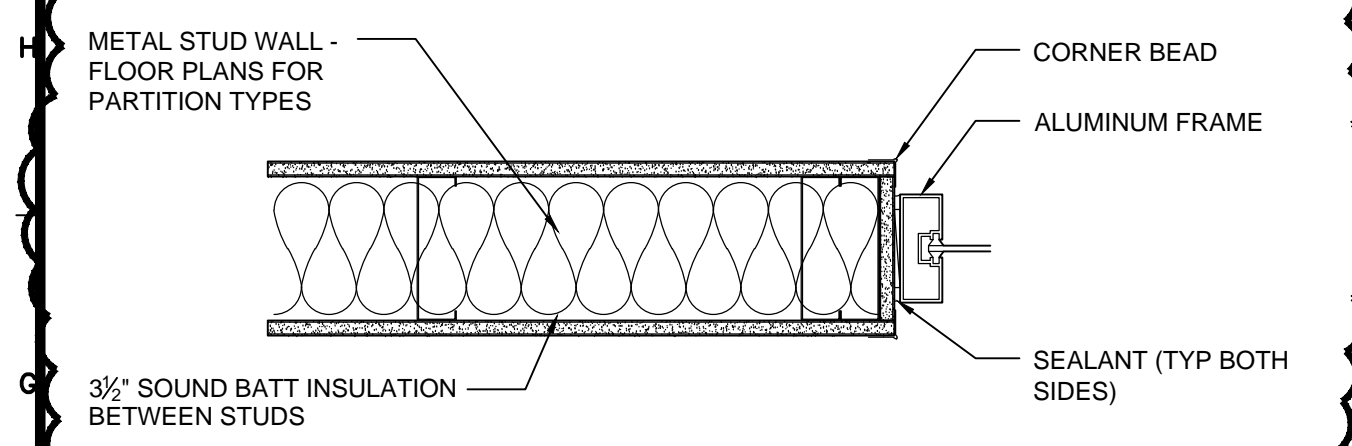

G1 WINDOW JAMB DETAIL @ ALUMINUM FRAME
1/12" = 1'-0"

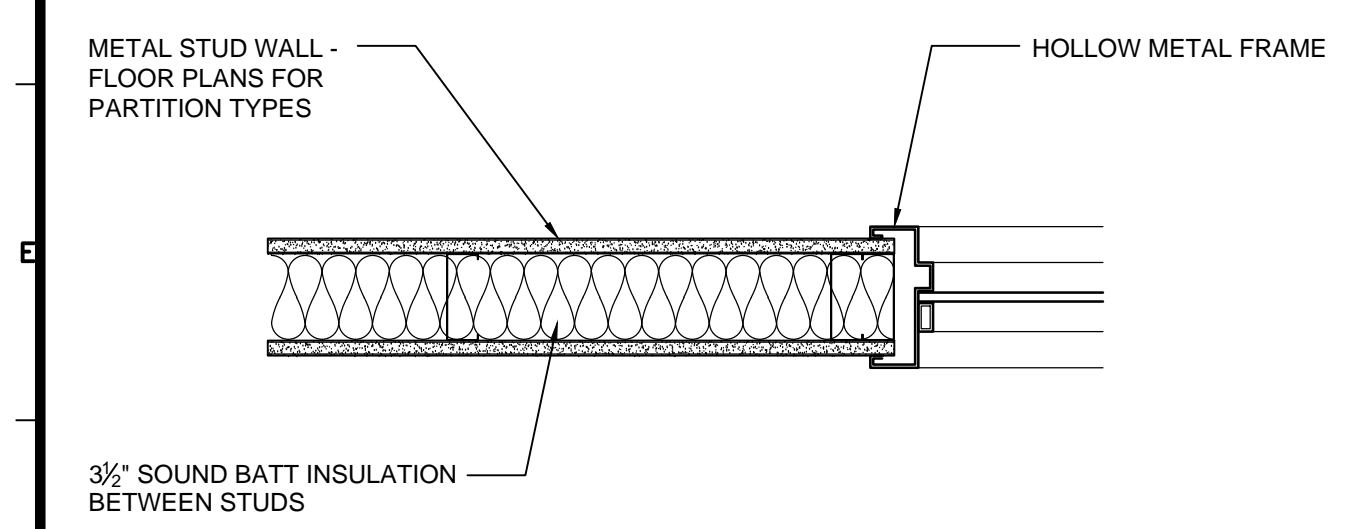

D1 WINDOW JAMB DETAIL @ HOLLOW METAL FRAME
1/12" = 1'-0"

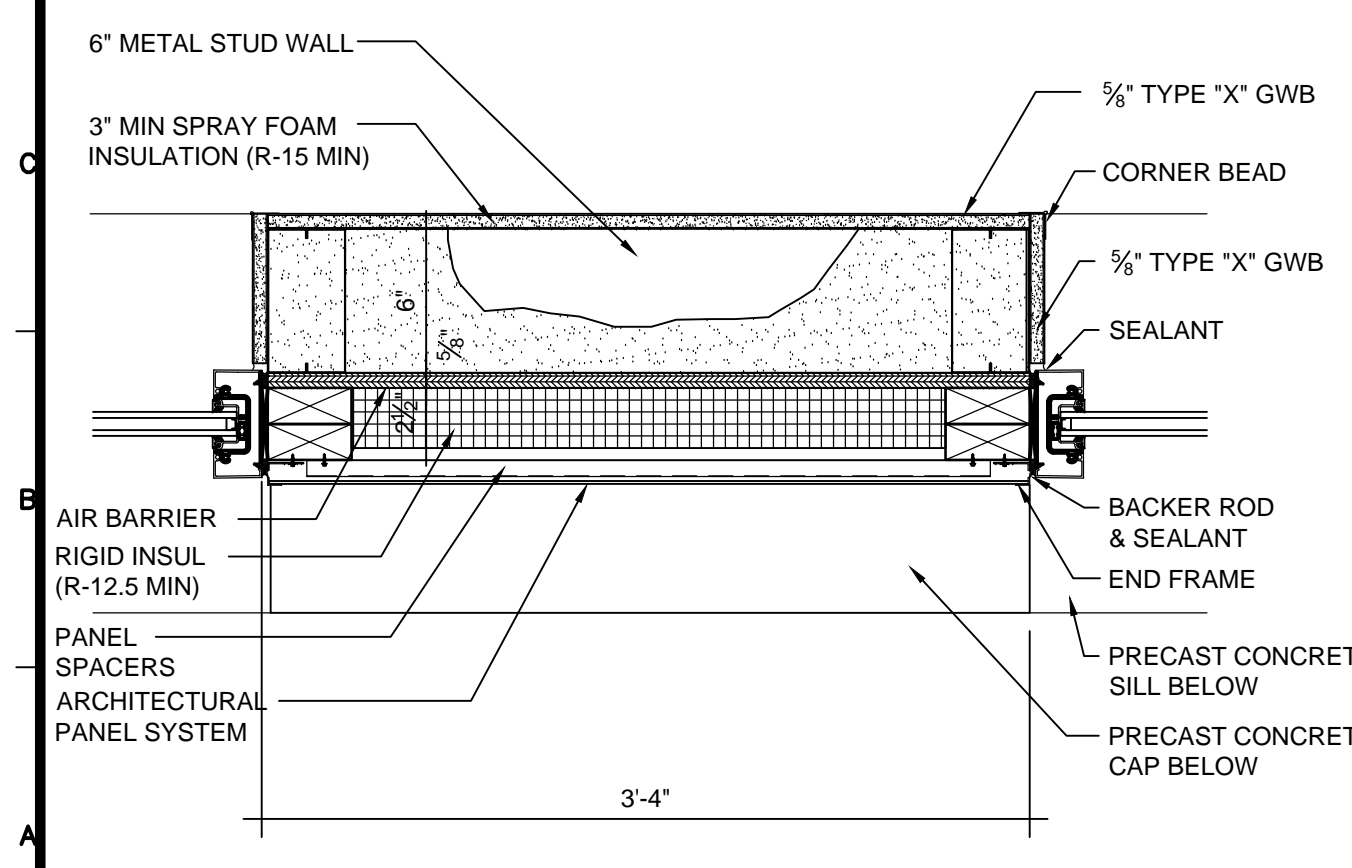

A1 WINDOW JAMB DETAIL @ METAL PANELS
1/12" = 1'-0"

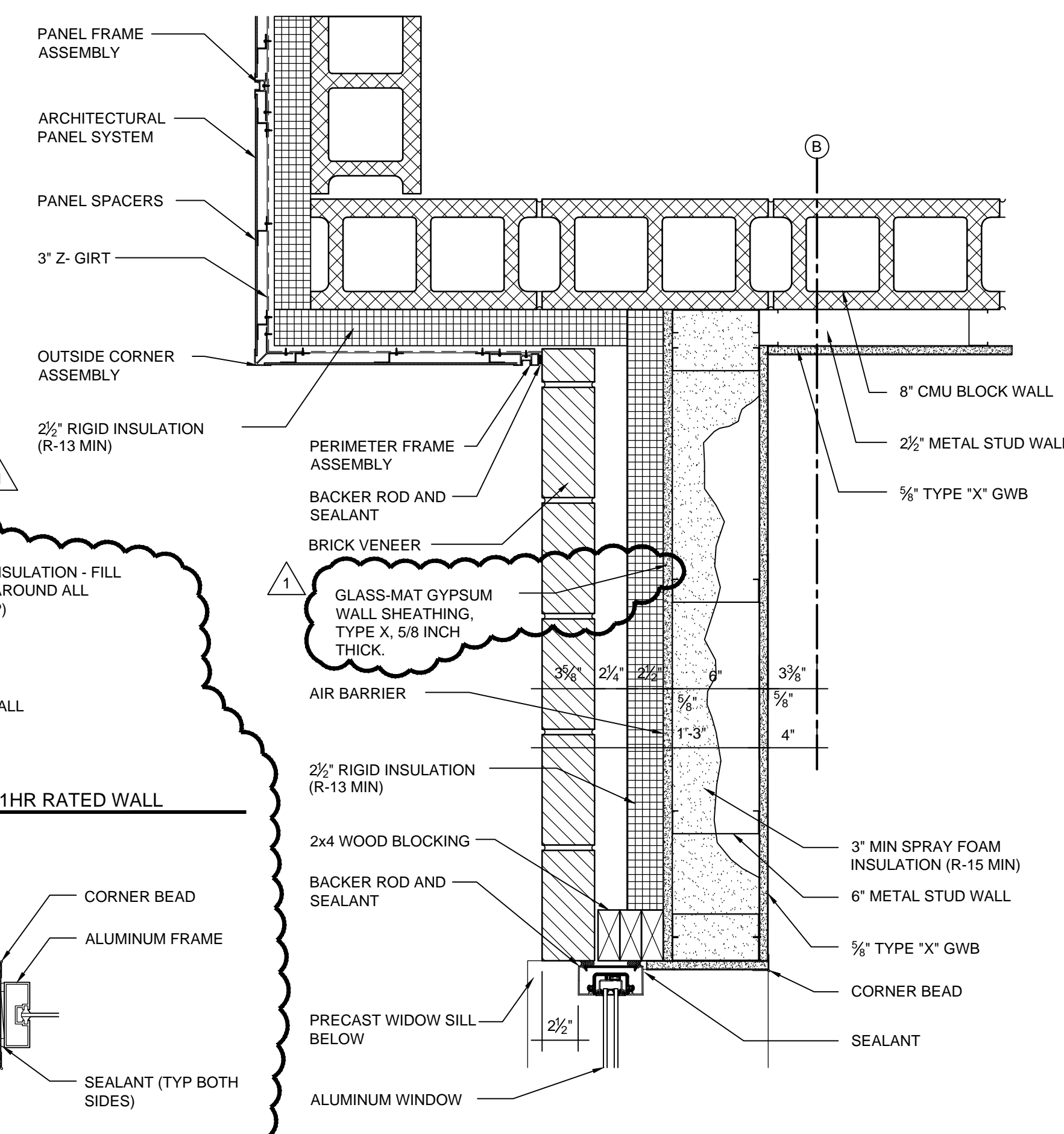

G4 PLAN DETAIL
1/12" = 1'-0"

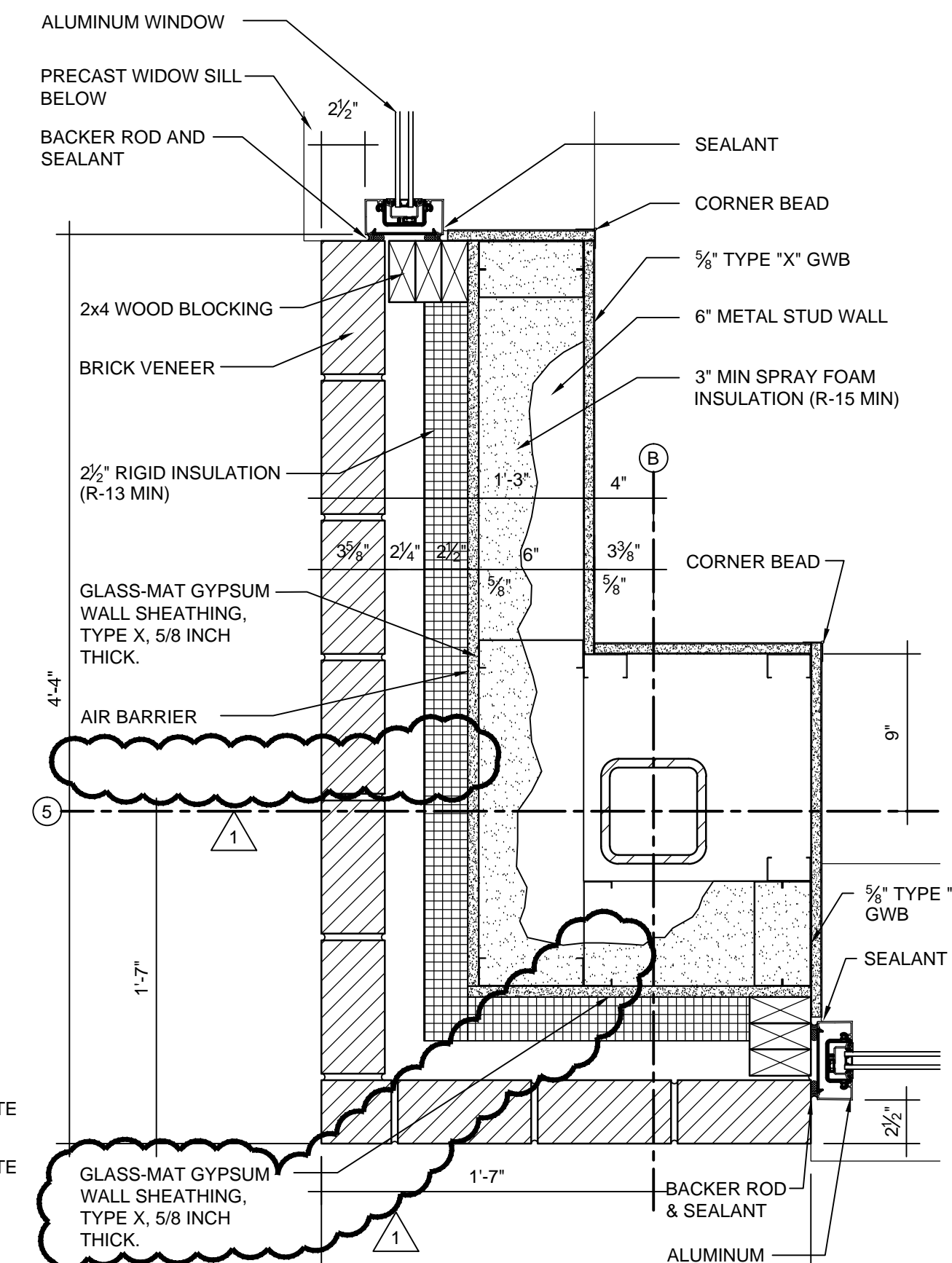

A4 PLAN DETAIL
1/12" = 1'-0"

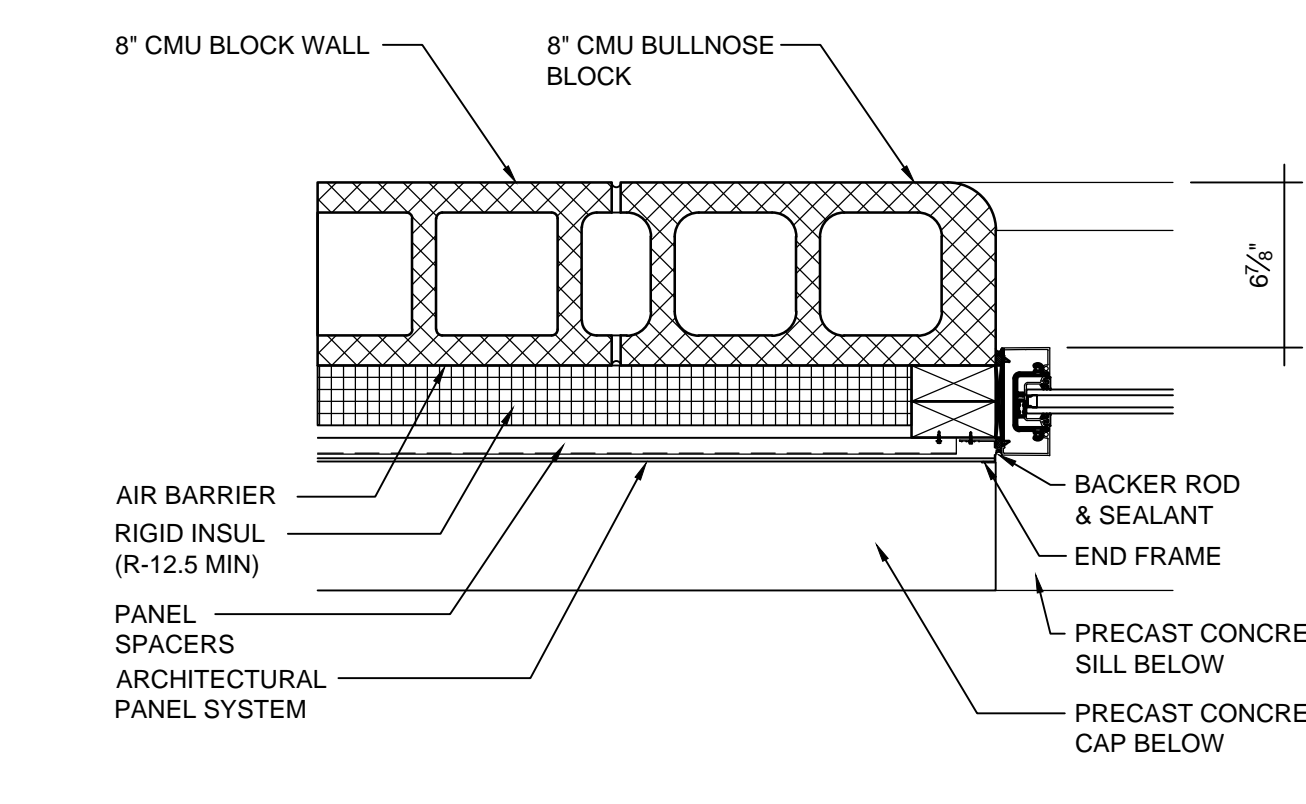

G11 WINDOW JAMB DETAIL @ METAL PANELS & CMU WALL
1/12" = 1'-0"

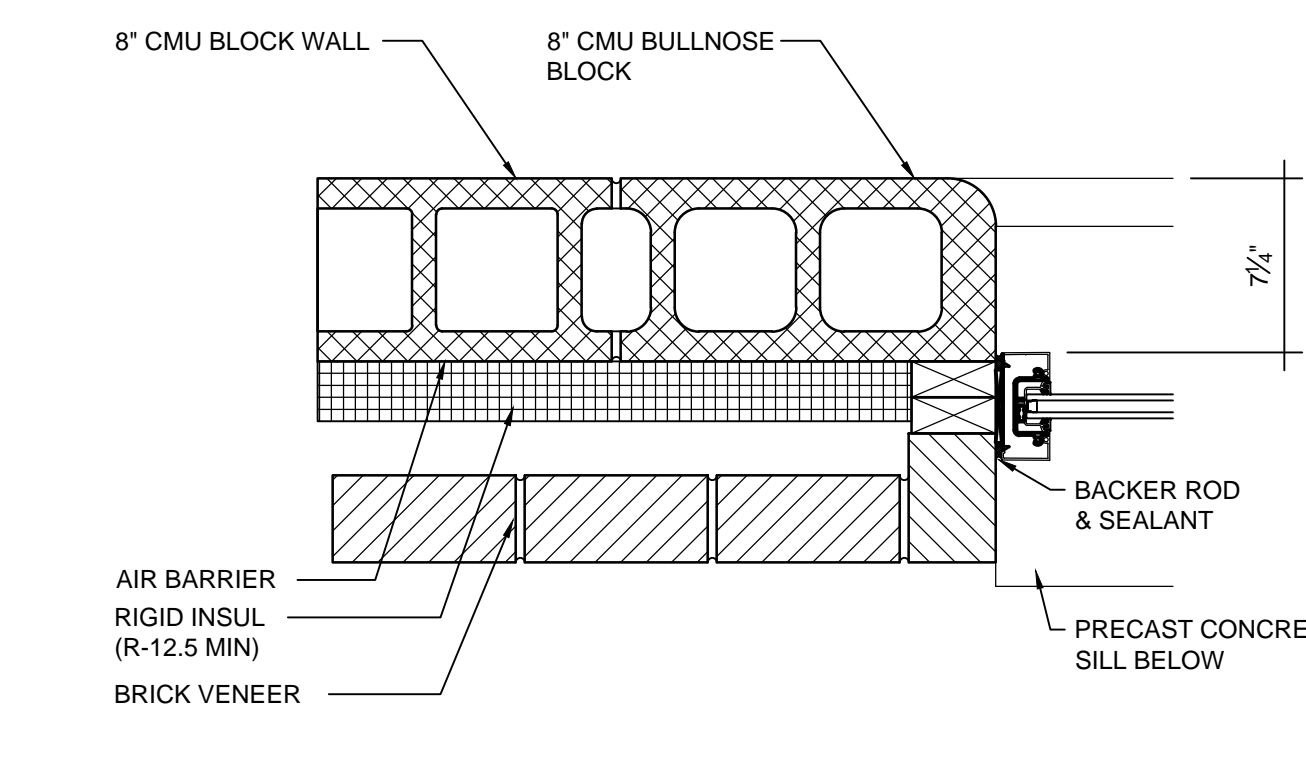

G8 WINDOW JAMB DETAIL @ BRICK VENEER & CMU WALL
1/12" = 1'-0"

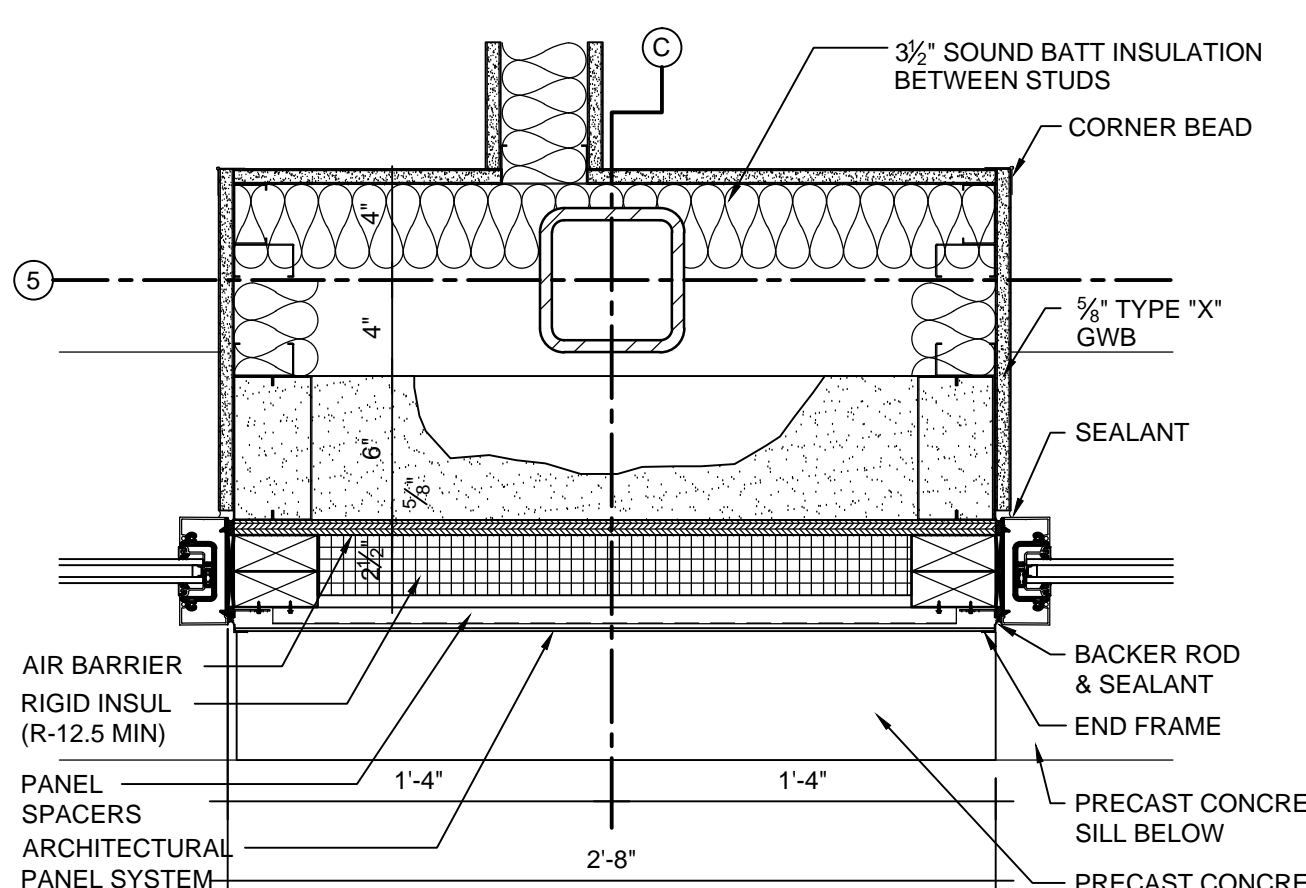

D8 WINDOW JAMB DETAIL @ METAL PANELS
1/12" = 1'-0"

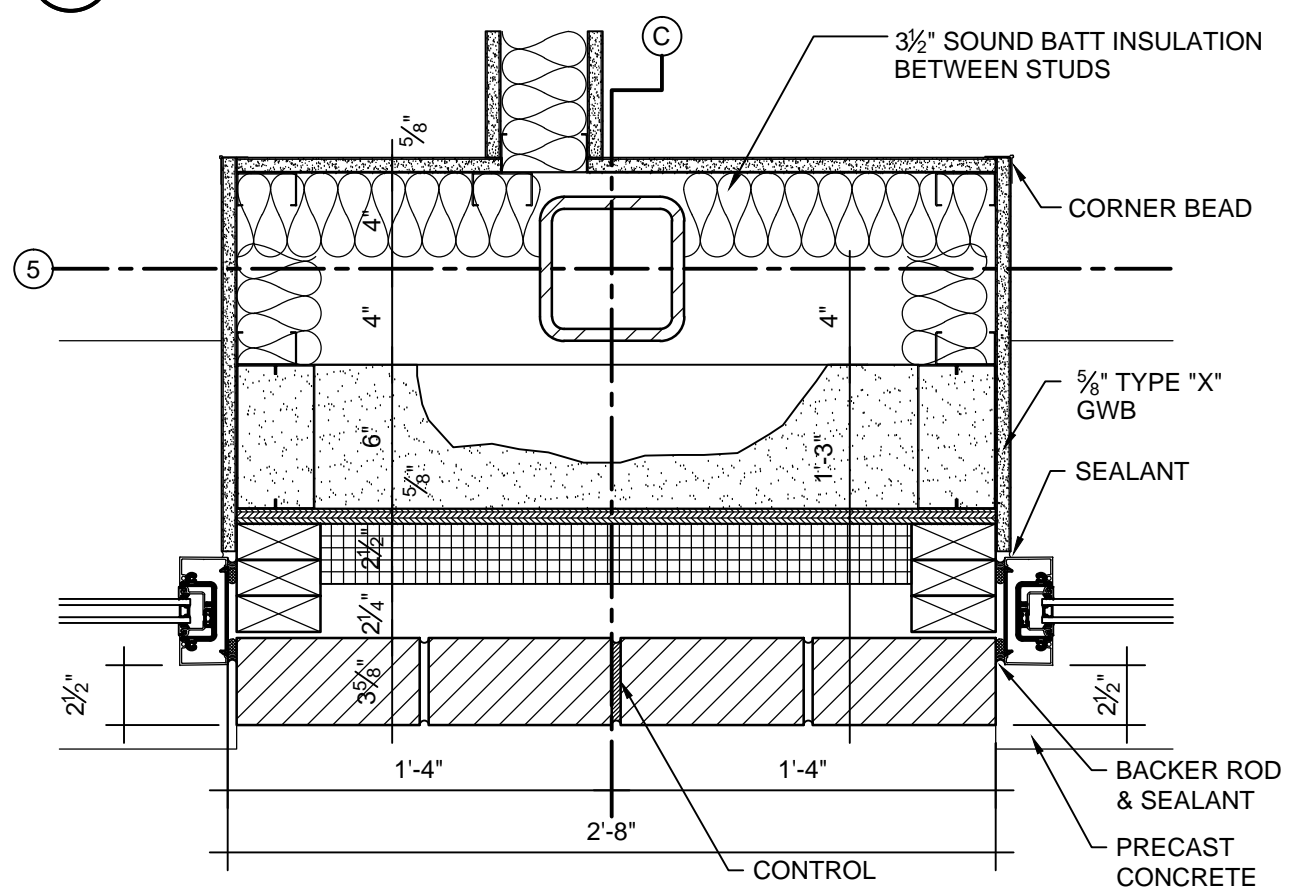

A8 WINDOW JAMB DETAIL @ BRICK VENEER
1/12" = 1'-0"

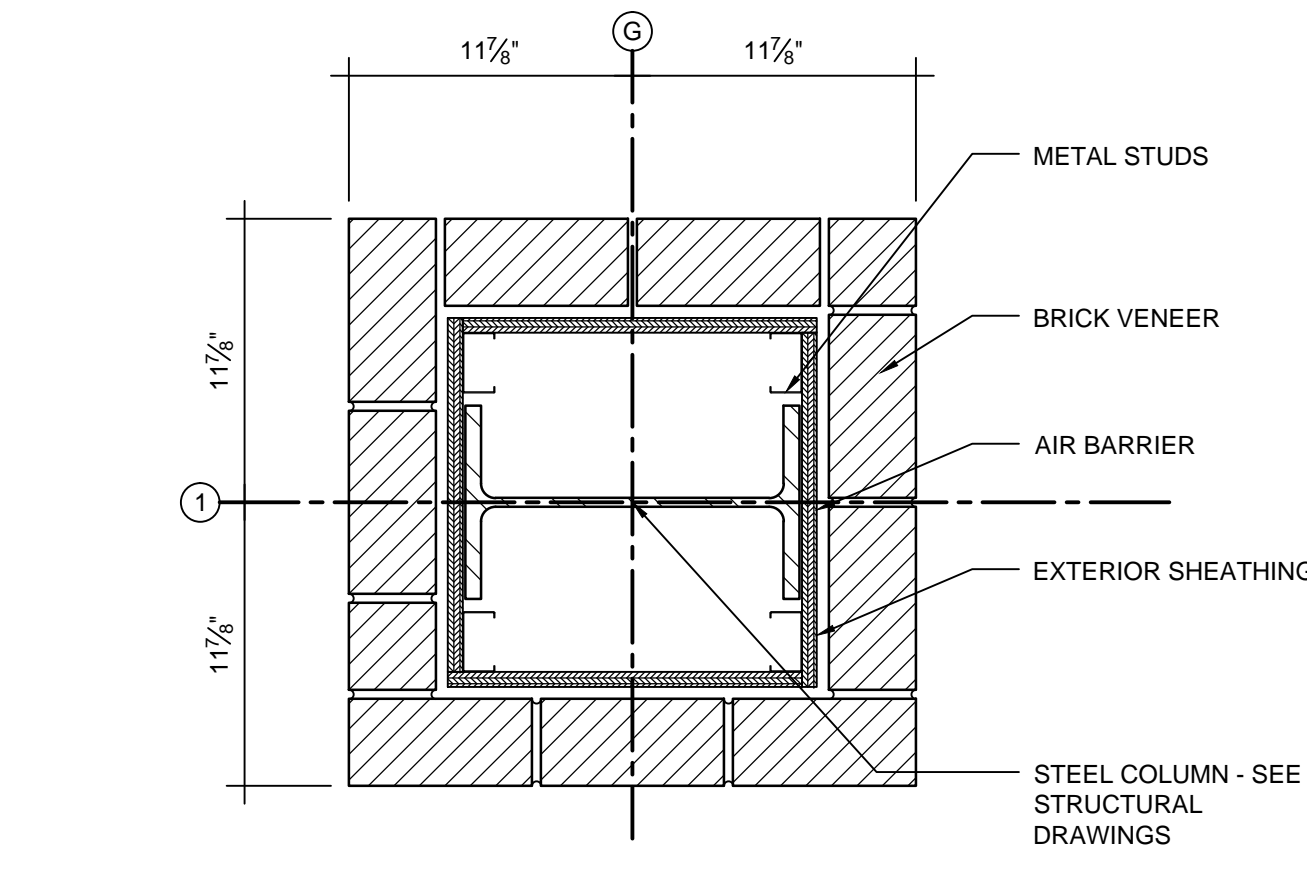

K11 PLAN DETAIL
1/12" = 1'-0"

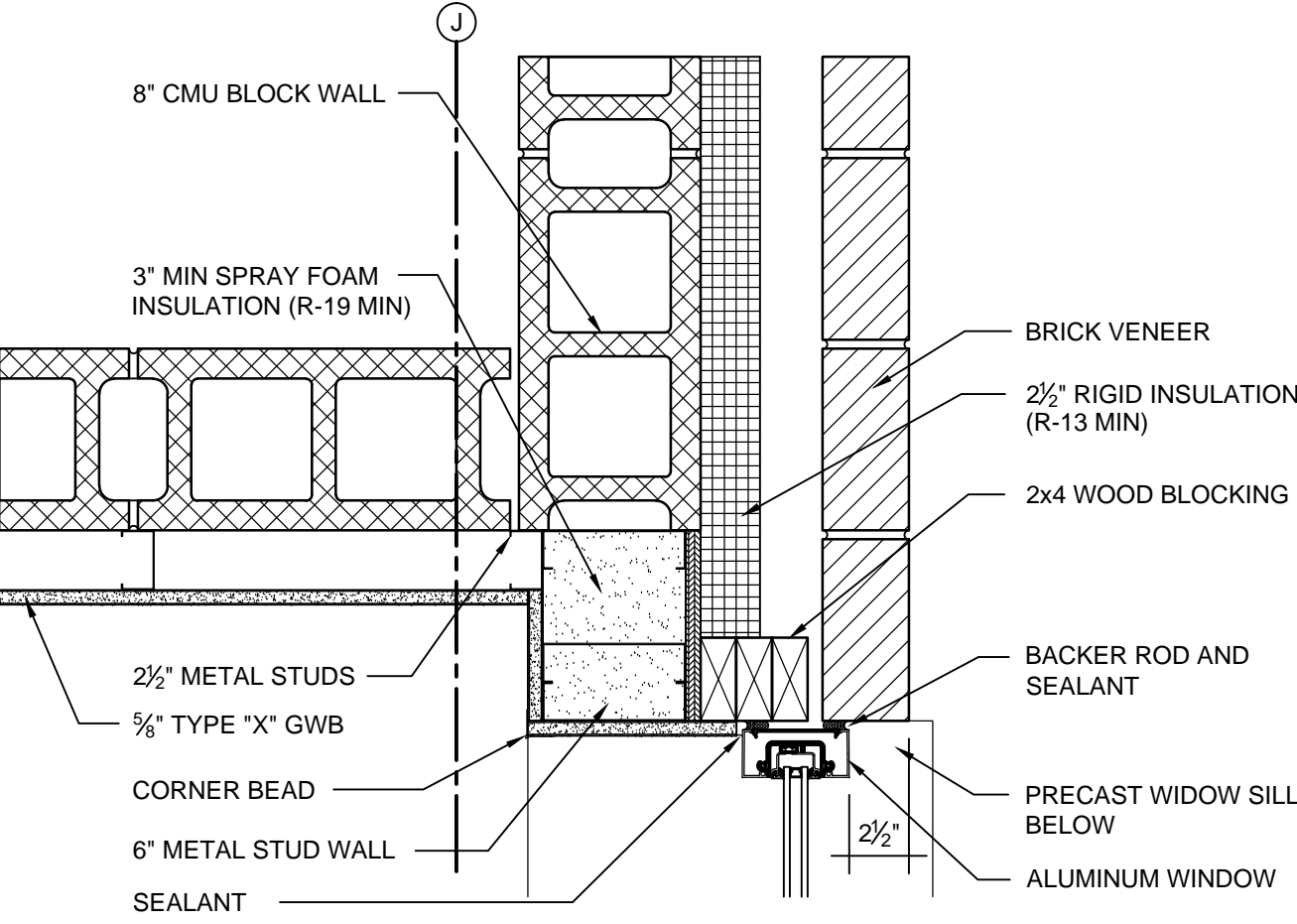

D11 PLAN DETAIL
1/12" = 1'-0"

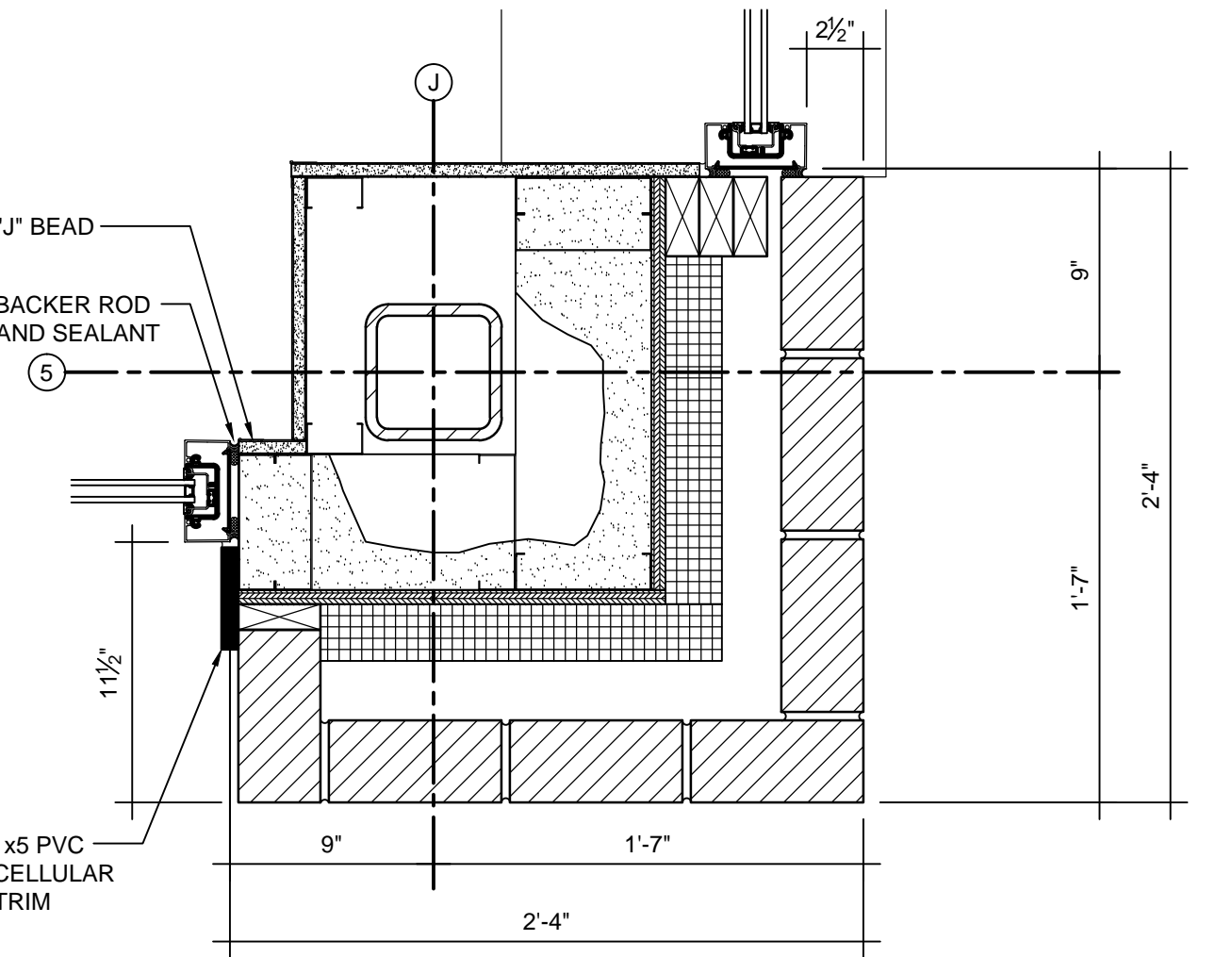

A11 PLAN DETAIL
1/12" = 1'-0"

1	09.23.15	ASI #003
0	03.31.15	SCHEMATIC DESIGN
NO.	DATE	DESCRIPTION

ISSUED FOR CONSTRUCTION
07.22.15

TAC Architectural Group Inc.

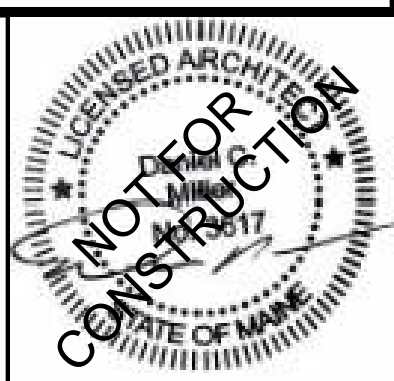

BSB - MARGINAL WAY
PORTLAND, MAINE

PROJECT NO: 14-007
CAD DWG FILE: AE503 PLAN DETAILS.DWG
DRAWN BY: CRJ
CHK'D BY: DCM
COPYRIGHT: 2015

SHEET TITLE
PLAN DETAILS
AE503