

**K1** PRECAST CONCRETE LINTEL  
3/8" = 1'-0"

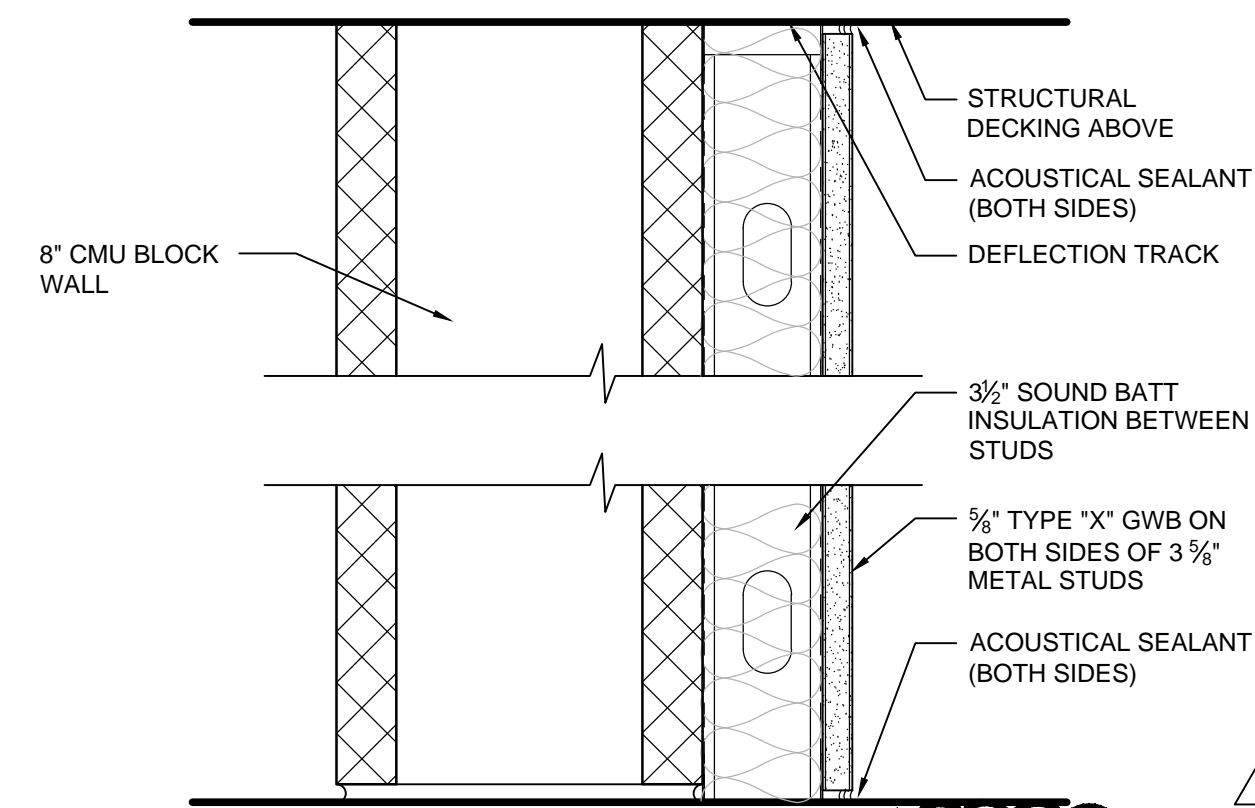

**K4** C02 - 8" CMU BLOCK WALL w/ 2 1/2" METAL STUDS  
3/8" = 1'-0"

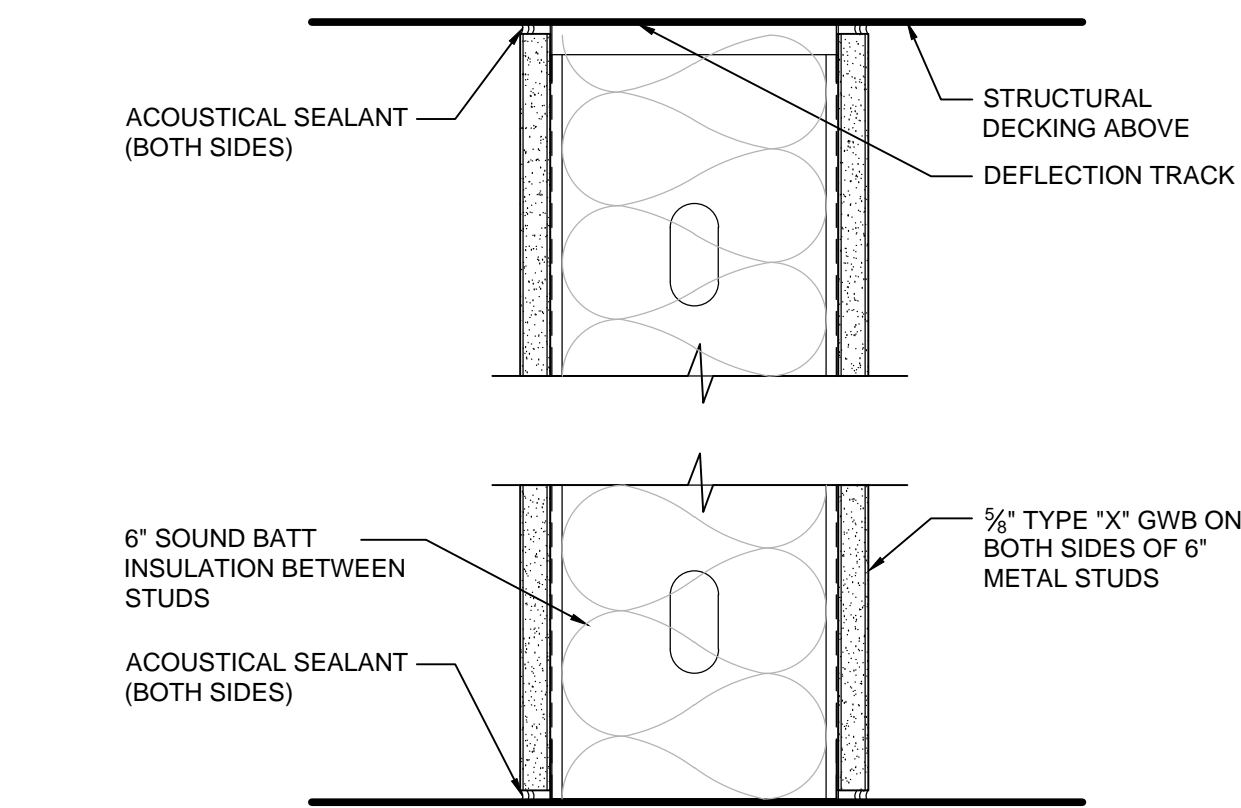

**K8** M07 - 6" METAL STUD WALL (SOUND)  
3/8" = 1'-0"

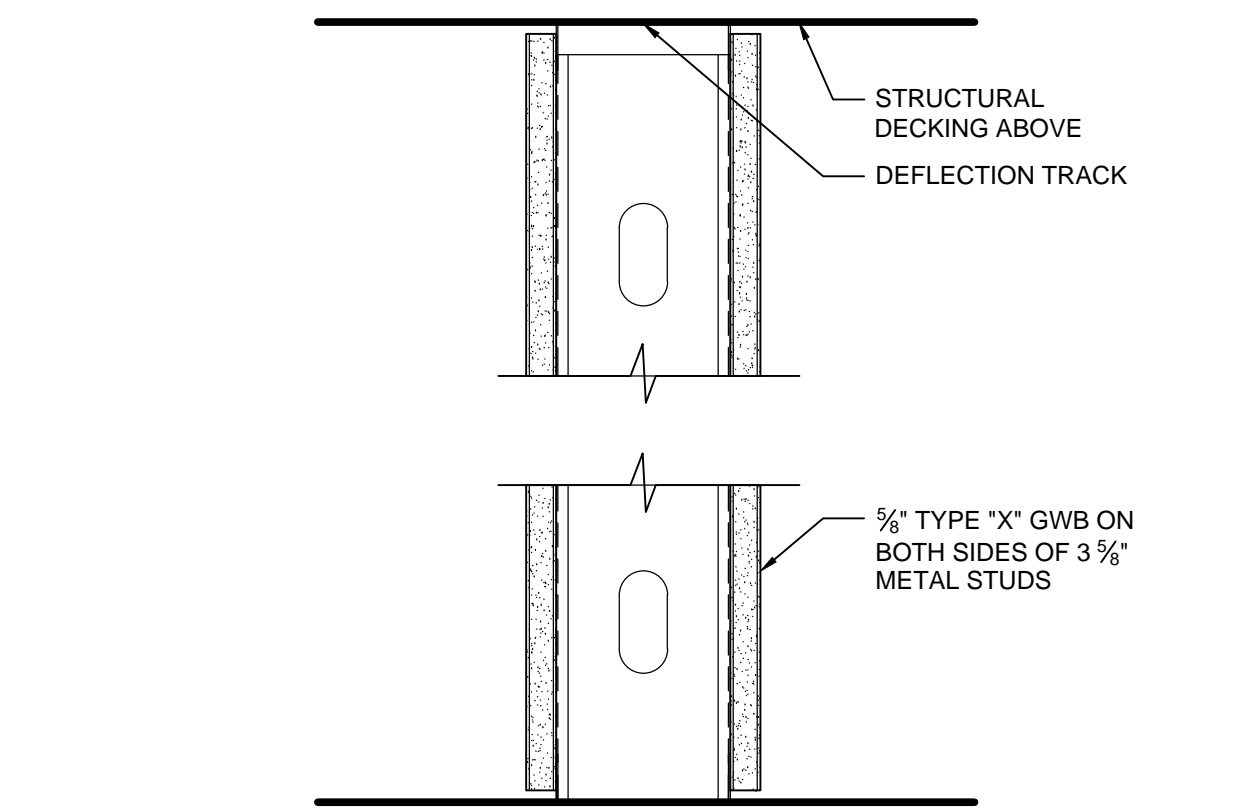

**K11** M01 - 3 5/8" METAL STUD WALL  
3/8" = 1'-0"

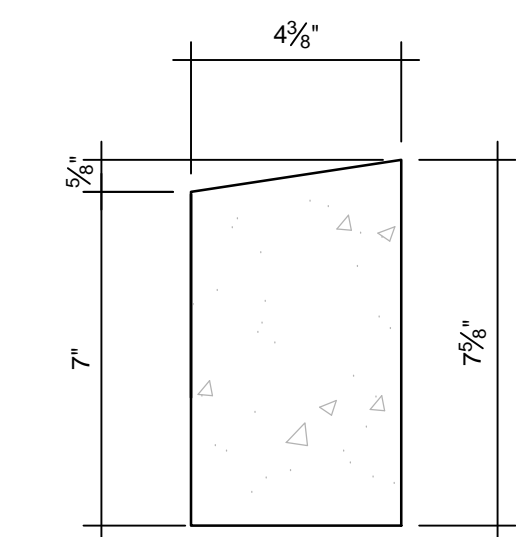

**G1** PRECAST CONCRETE SILL  
3/8" = 1'-0"

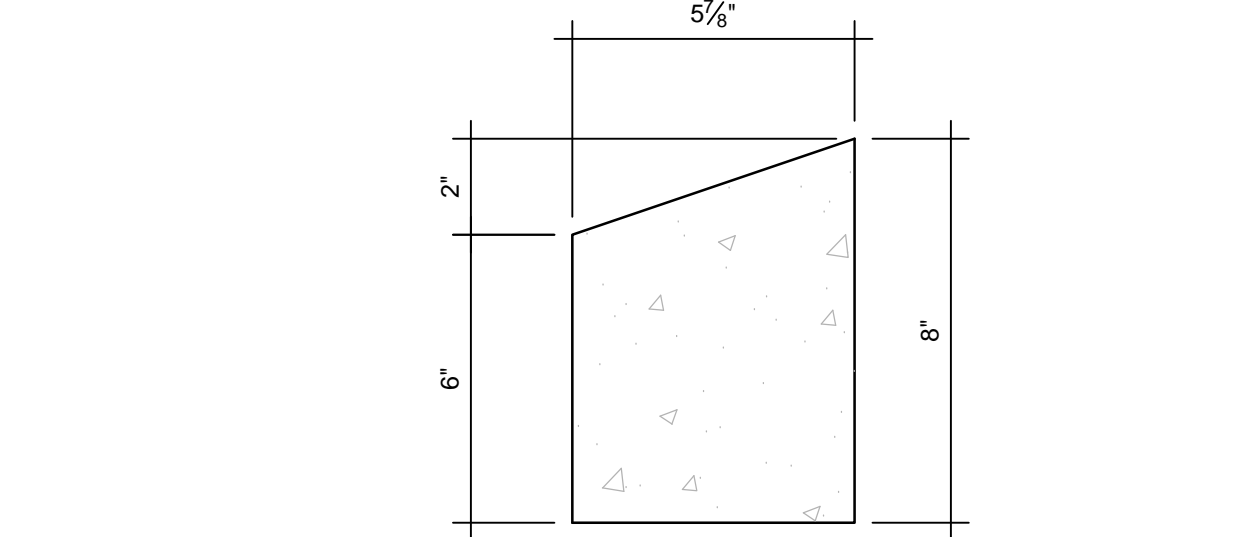

**G4** PRECAST CONCRETE CAP  
3/8" = 1'-0"

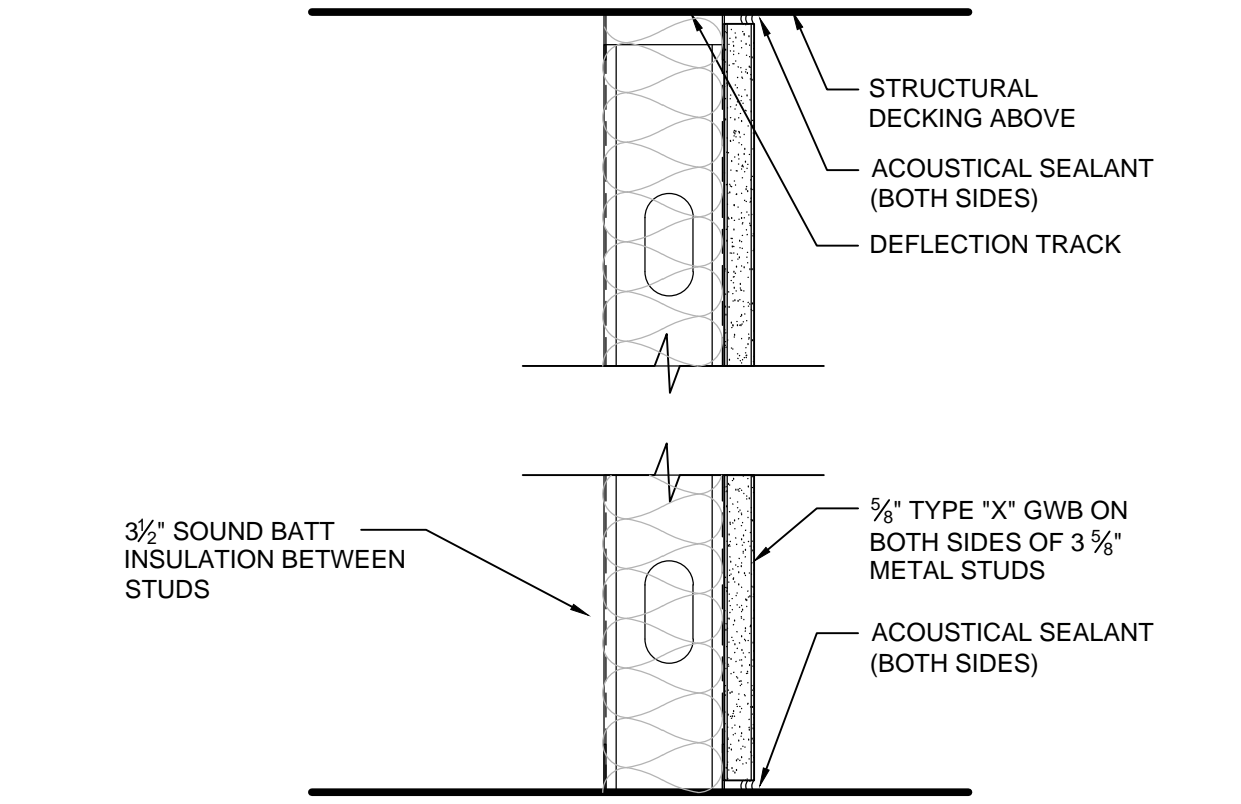

**G8** M12 - 2 1/2" METAL STUD CHASE WALL - SOUND  
3/8" = 1'-0"

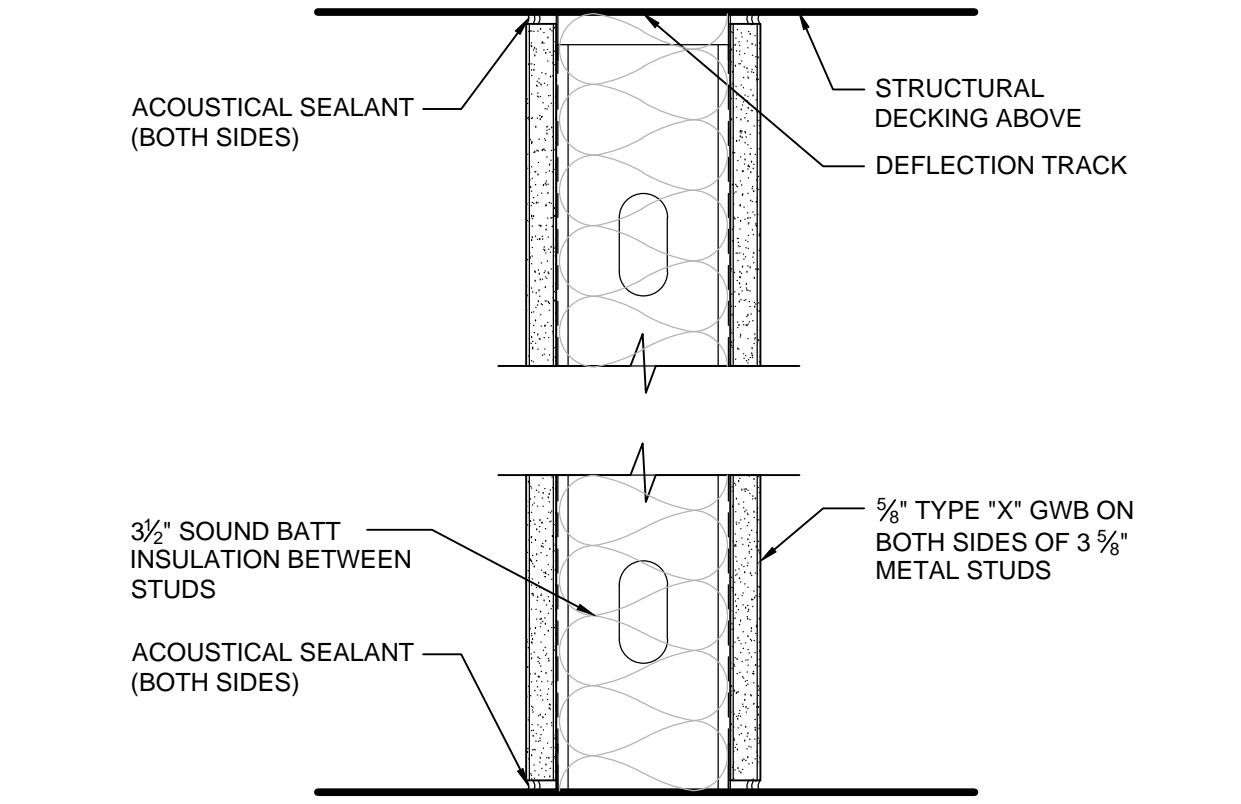

**G11** M02 - 3 5/8" METAL STUD WALL (SOUND)  
3/8" = 1'-0"

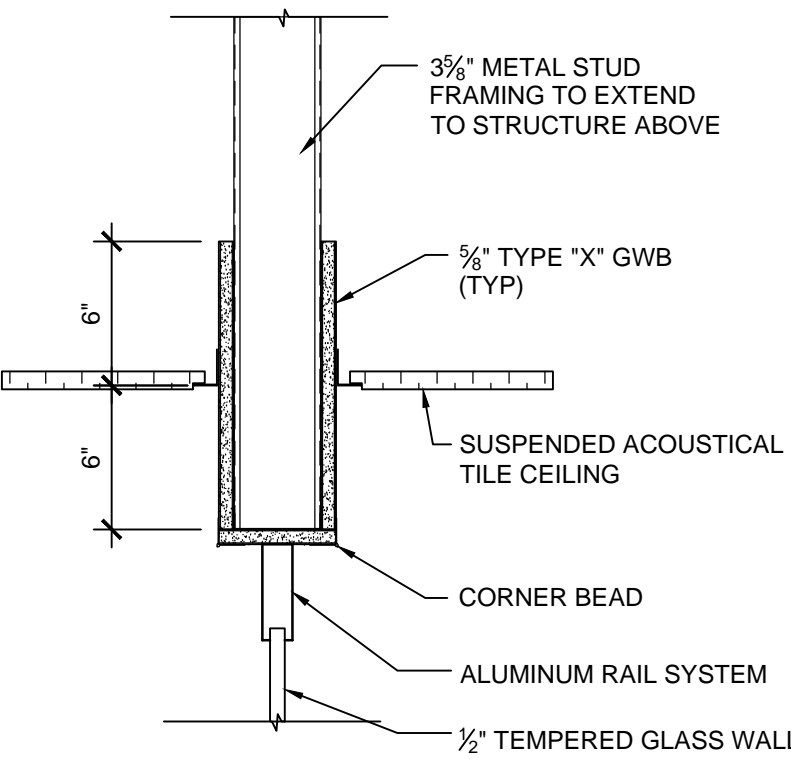

**D1** SOFFIT DETAIL @ ALL-GLASS STOREFRONT  
1 1/2" = 1'-0"

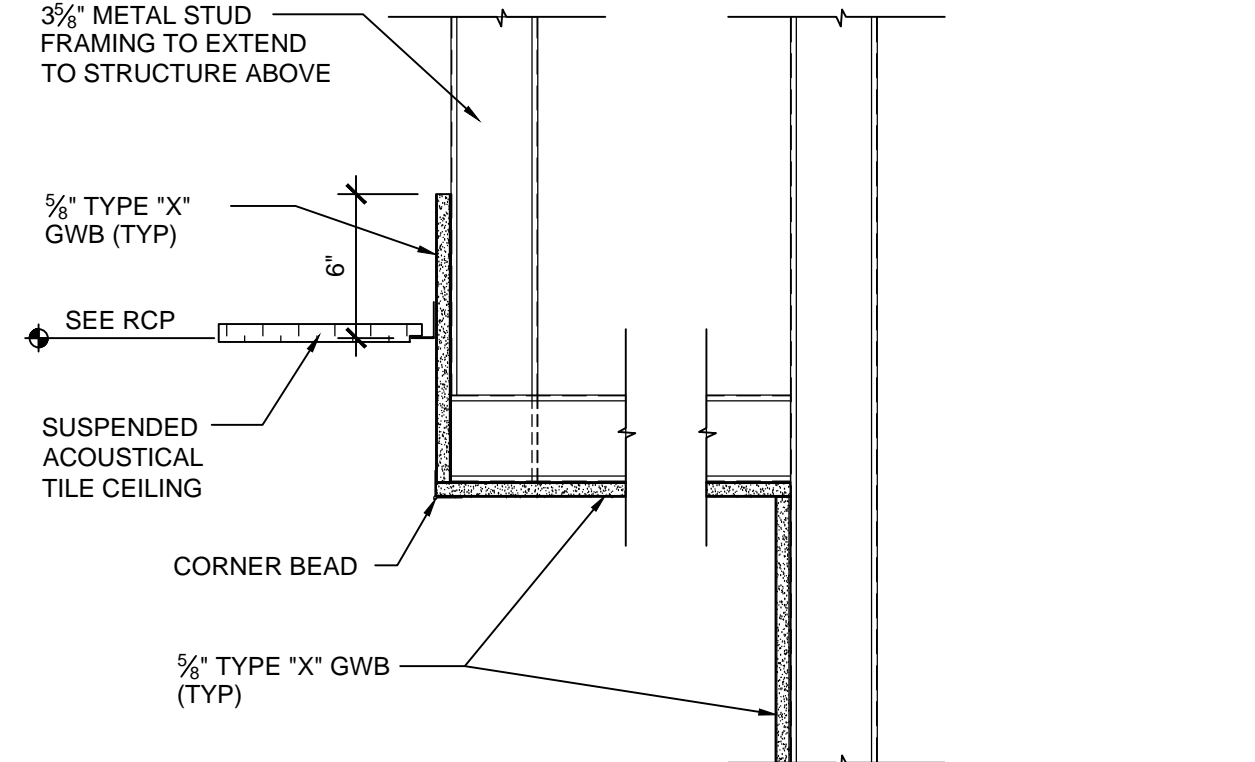

**D4** GWB SOFFIT DETAIL  
1 1/2" = 1'-0"

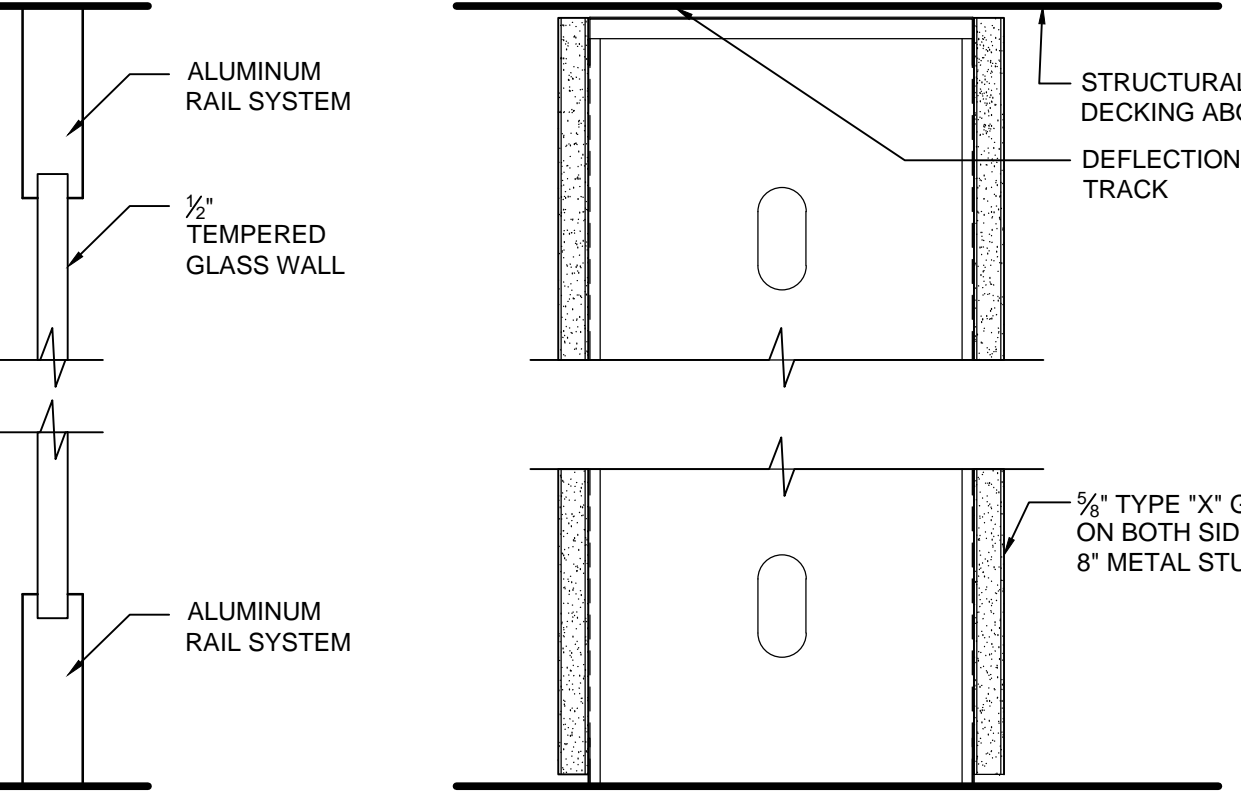

**D7** G01 - GLASS WALL  
3/8" = 1'-0"

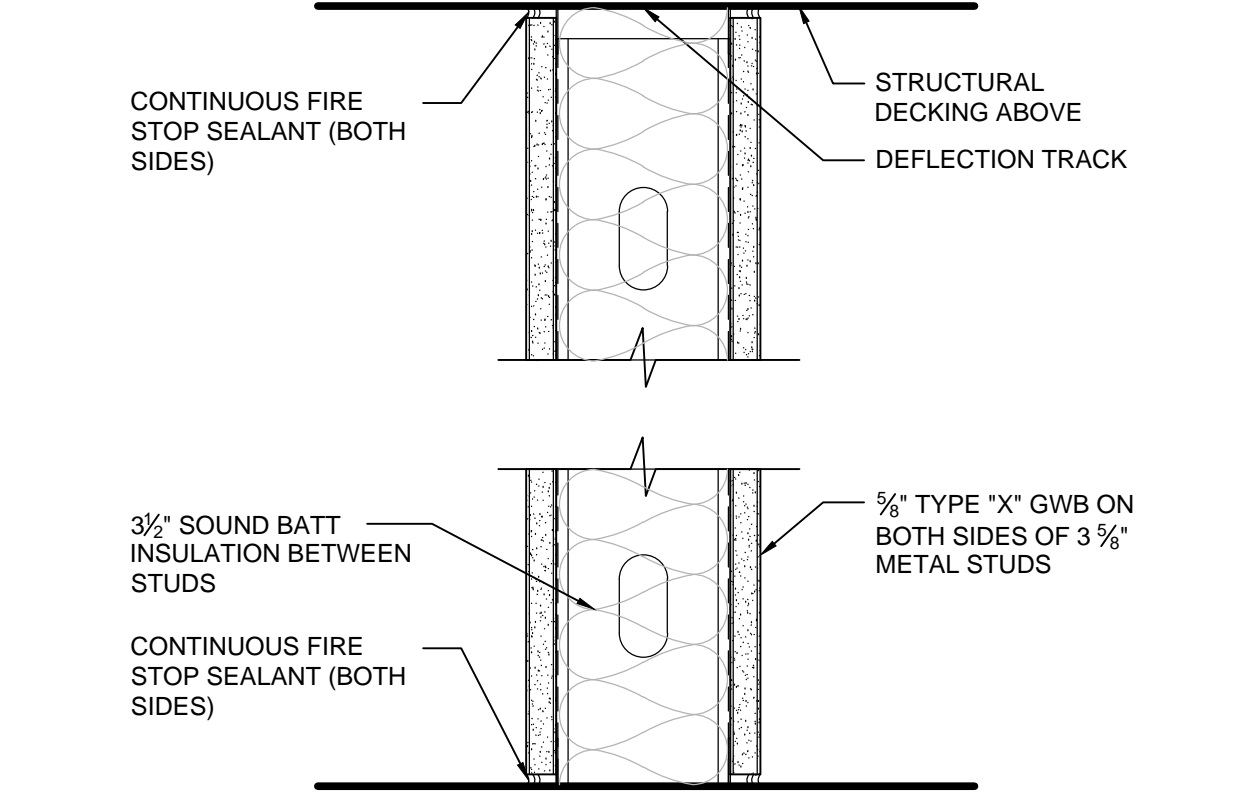

**D11** M03 - 3 5/8" METAL STUD WALL (1 HOUR RATED)  
3/8" = 1'-0"

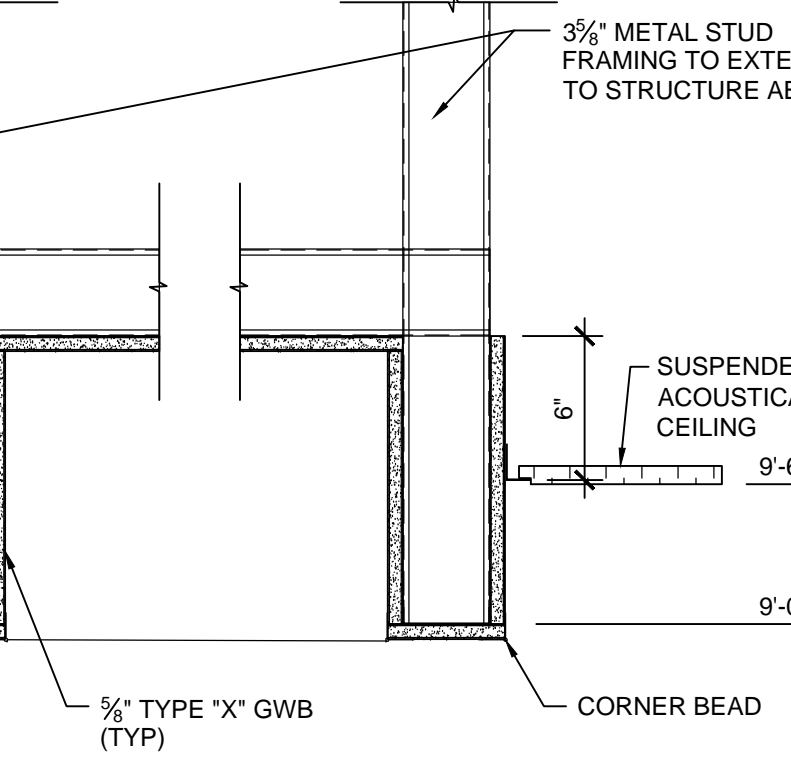

**A1** SOFFIT DETAIL @ TELLER LINE  
1 1/2" = 1'-0"

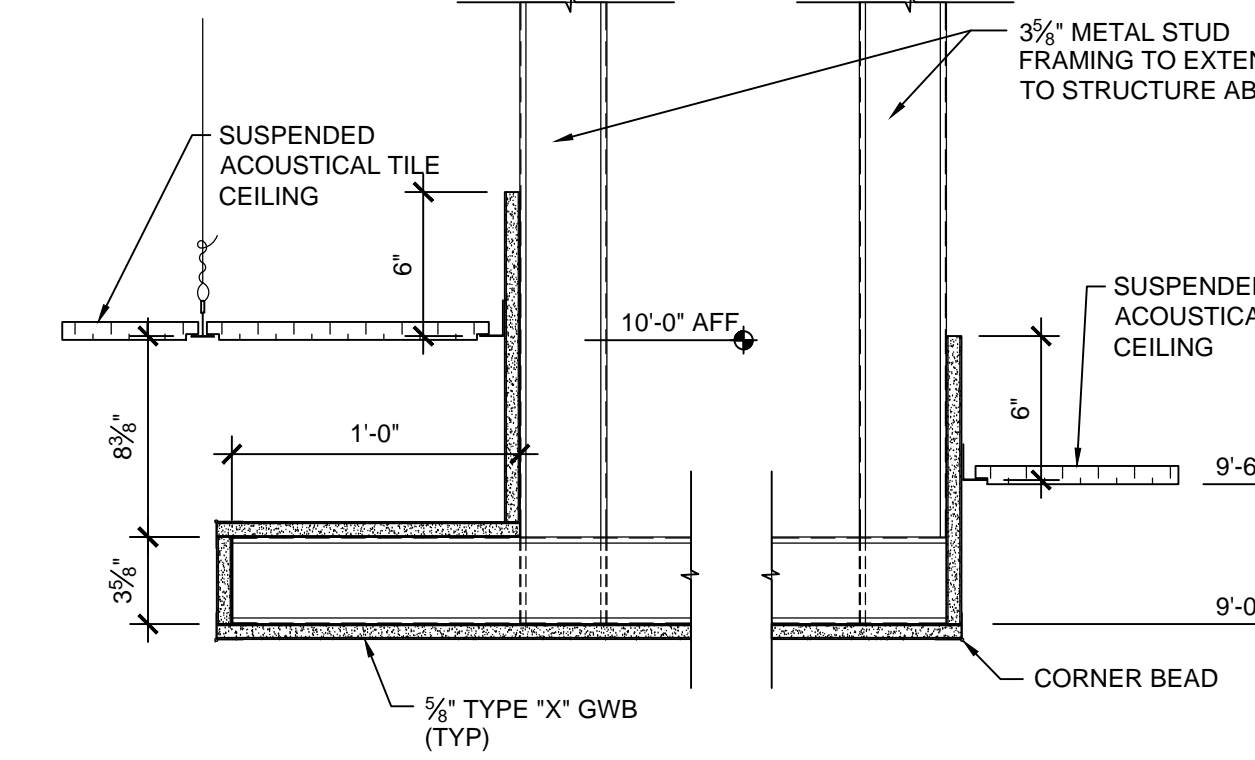

**A4** SOFFIT DETAIL @ TELLER LINE  
1 1/2" = 1'-0"

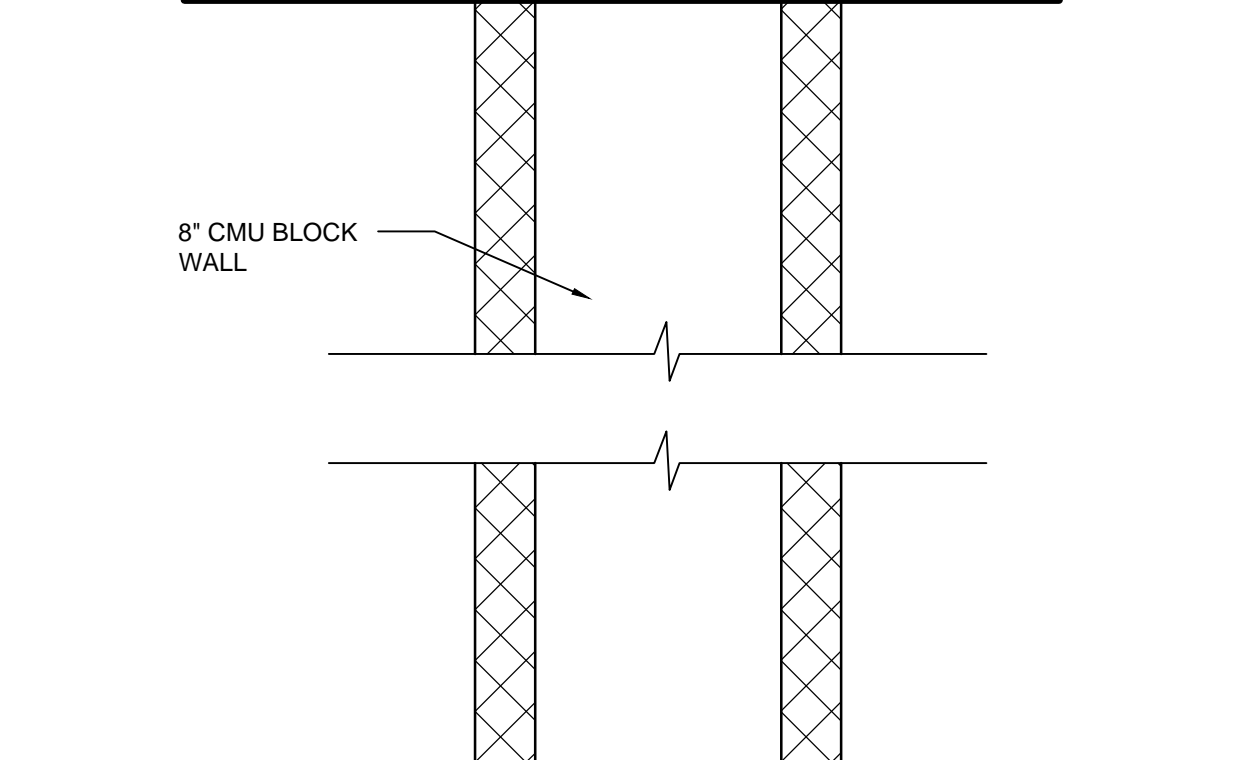

**A8** C01 - 8" CMU BLOCK WALL  
3/8" = 1'-0"

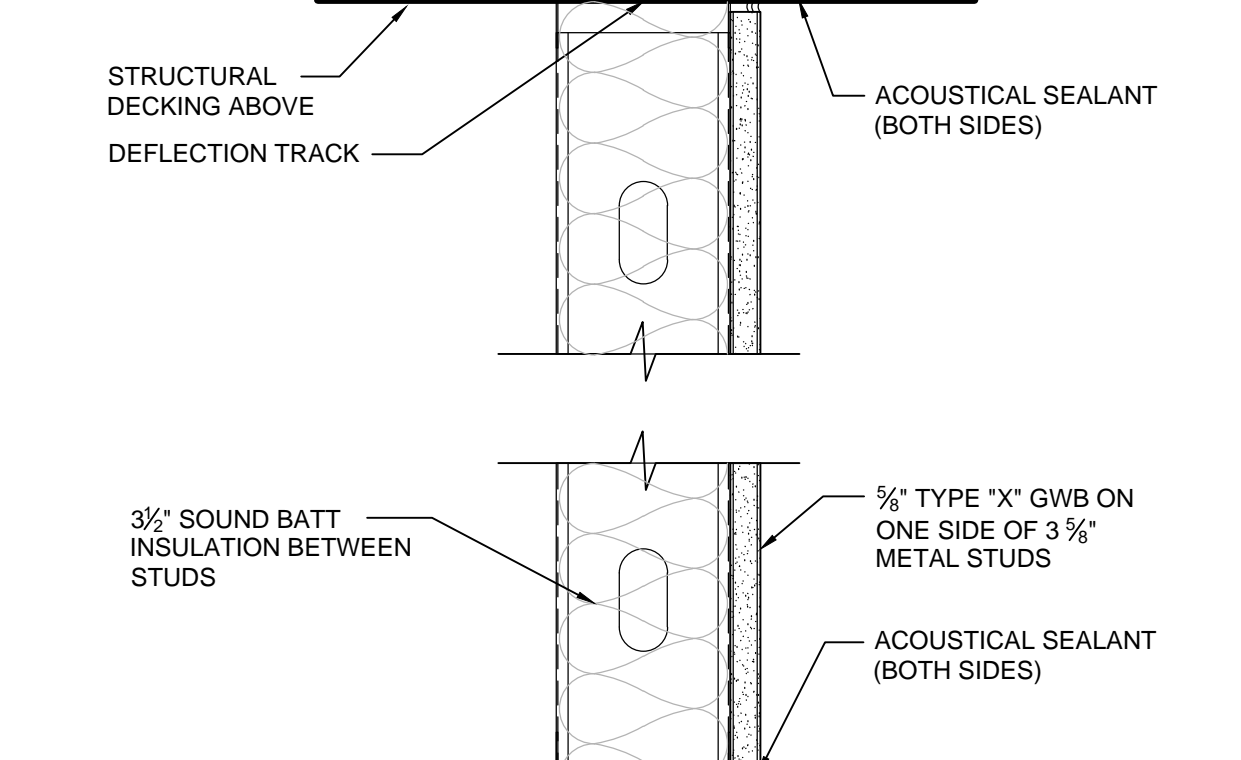

**A11** M05 - 3 5/8" METAL STUD CHASE WALL (SOUND)  
3/8" = 1'-0"

1	09.23.15	AS1 #003
0	03.31.15	SCHEMATIC DESIGN
NO.	DATE	DESCRIPTION

ISSUED FOR CONSTRUCTION  
07.22.15

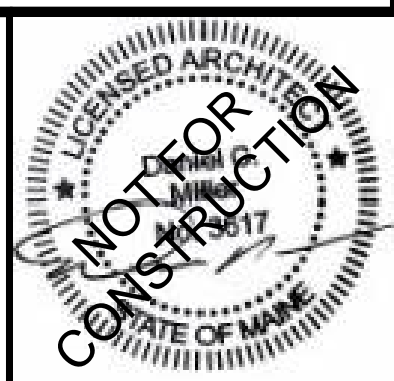

BSB - MARGINAL WAY  
PORTLAND, MAINE

PROJECT NO:	14-007
CAD DWG FILE:	AE502 PARTITION TYPES.DWG
DRAWN BY:	CRJ
CHK'D BY:	DCM
COPYRIGHT:	2015

SHEET TITLE  
**PARTITION TYPES**

AE502