

Job Name: _____	Client Name: _____
Job Location - City: _____ State: _____	Created By: _____ Date: _____
Product: _____ Quote: _____	Customer Approval: _____ Date: _____

SPECIFICATIONS

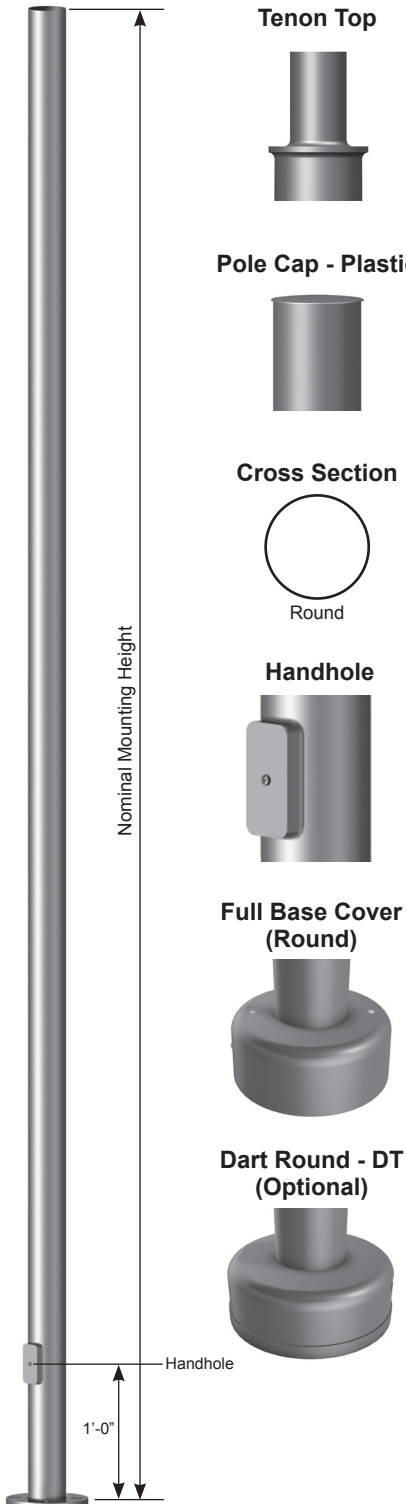

Pole Shaft - The pole shaft is fabricated from hot rolled welded steel tubing of one-piece construction with a minimum yield strength of 42 KSI.

Pole Top - A removable pole cap is provided for poles receiving drilling patterns for side-mount luminaire arm assemblies. For top mount luminaire and/or bracket consult the factory. Consult the luminaire manufacturer for correct tenon size or drill pattern. Other pole top options include pole cap only (PC) or plain top (PL) which is typical when the pole top diameter matches the necessary slip fit dimensions.

Handhole - A reinforced handhole with grounding provision is provided at 1'-0" from the base end of the pole assembly. Each handhole includes a cover and the cover attachment hardware. All pole assemblies are provided with a 2.5" x 5" rectangular handhole. Handhole dimensions are nominal.

Base Cover - A two-piece full base cover fabricated from ABS plastic is provided with each pole assembly. Additional base cover options, including the dart round (DT) cast aluminum cover, are available upon request.

Anchor Bolts - Anchor bolts conform to ASTM F1554 Grade 55 and are provided with two hex nuts and two flat washers. Bolts have an "L" bend on one end and are galvanized a minimum of 12" on the threaded end.

Hardware - All structural fasteners are galvanized high strength carbon steel. All non-structural fasteners are galvanized or zinc-plated carbon steel or stainless steel.

Finish - Standard finishes are Galvanized (GV) or Finish Painted (FP). Additional finish options, including Finish Paint over Galvanizing (FPGV) or any of the V-PRO™ Finish Coating Systems are available upon request. See the product ordering code for color options.

Design Criteria - Please reference Design Criteria Specification for appropriate design conditions.

ROUND NON-TAPERED STEEL DS340



STRUCTURES

Job Name: _____	Client Name: _____
Job Location - City: _____ State: _____	Created By: _____ Date: _____
Product: _____ Quote: _____	Customer Approval: _____ Date: _____

DESIGNATION, LOAD AND DIMENSIONAL DATA

NOMINAL MOUNTING HEIGHT	DESIGN INFORMATION						POLE DIMENSIONS				DESIGNATION
	80 MPH w/1.3 GUST		90 MPH w/1.3 GUST		100 MPH w/1.3 GUST		BASE OD (IN)	TOP OD (IN)	WALL THK (IN)	STRUCTURE WEIGHT ² (LBS)	
	MAX EPA ¹ (SQFT)	MAX WEIGHT ¹ (LBS)	MAX EPA ¹ (SQFT)	MAX WEIGHT ¹ (LBS)	MAX EPA ¹ (SQFT)	MAX WEIGHT ¹ (LBS)					
10'-0"	10.0	250	7.7	190	6.0	175	3.00	3.00	0.120	55	300V100
	19.1	480	15.0	375	12.2	305	4.00	4.00	0.120	70	400V100
	24.5	615	19.5	490	15.8	395	4.50	4.50	0.120	75	450V100
12'-0"	7.7	195	5.8	145	4.4	130	3.00	3.00	0.120	60	300V120
	15.0	390	11.8	300	9.5	240	4.00	4.00	0.120	80	400V120
	19.8	495	15.7	395	12.7	320	4.50	4.50	0.120	85	450V120
	25.0	625	20.0	500	16.4	410	5.00	5.00	0.120	90	500V120
14'-0"	6.0	175	4.4	130	3.3	90	3.00	3.00	0.120	70	300V140
	12.2	305	9.4	250	7.6	195	4.00	4.00	0.120	90	400V140
	16.2	405	12.8	320	10.3	260	4.50	4.50	0.120	95	450V140
16'-0"	4.6	125	3.2	100	2.3	60	3.00	3.00	0.120	80	300V160
	9.6	250	7.4	185	5.9	150	4.00	4.00	0.120	100	400V160
	13.1	330	10.2	265	8.2	205	4.50	4.50	0.120	105	450V160
18'-0"	3.4	90	2.3	60	1.4	70	3.00	3.00	0.120	90	300V180
	7.6	190	5.7	180	4.5	130	4.00	4.00	0.120	110	400V180
	10.5	265	8.2	210	6.5	165	4.50	4.50	0.120	115	450V180
20'-0"	2.4	100	1.4	75	N/A	N/A	3.00	3.00	0.120	100	300V200
	6.0	150	4.4	150	3.4	125	4.00	4.00	0.120	120	400V200
	8.5	215	6.6	165	5.2	130	4.50	4.50	0.120	130	450V200
	11.7	300	9.1	230	7.2	180	5.00	5.00	0.120	145	500V200
25'-0"	2.8	100	1.9	75	1.3	75	4.00	4.00	0.120	145	400V250
	4.8	130	3.6	90	2.7	90	4.50	4.50	0.120	155	450V250
	7.2	180	5.5	150	4.2	150	5.00	5.00	0.120	180	500V250
	12.1	300	9.4	250	7.4	200	5.00	5.00	0.180	260	5006250
30'-0"	2.3	80	1.5	75	1.0	60	4.50	4.50	0.120	185	450V300
	4.2	150	3.0	125	2.2	100	5.00	5.00	0.120	210	500V300
	8.0	200	6.5	160	4.7	125	5.00	5.00	0.180	305	5006300

- Maximum EPA (Effective Projected Area) and weight values are based on side mounted fixtures only. Consult factory on loading criteria for pole top mounted luminaires and/or brackets. Variations from sizes above are available upon inquiry at the factory. Satisfactory performance of poles is dependent upon the pole being properly attached to a supporting foundation of adequate design.
- Structure weight is a nominal value which includes the pole shaft and base plate only.

ANCHORAGE DATA

POLE		BASE PLATE				ANCHOR BOLTS			
BASE OD (IN)	WALL THK (IN)	BOLT CIRCLE		DIAMETER (IN)	THK (IN)	DIA x LENGTH x HOOK (IN)	PROJECTION (IN)	± (IN)	
		DIA (IN)	± (IN)						
3.00	0.120	8.00	1.00	10.50	0.750	0.75 x 17.00 x 3.00	3.50	0.25	
4.00	0.120	8.00	1.00	10.50	0.750	0.75 x 17.00 x 3.00	3.50	0.25	
4.50	0.120	8.00	1.00	10.50	0.750	0.75 x 17.00 x 3.00	3.50	0.25	
5.00	0.120	8.00	1.00	10.50	0.750	0.75 x 17.00 x 3.00	3.50	0.25	
5.00	0.180	8.00	1.00	10.50	0.750	0.75 x 17.00 x 3.00	3.50	0.25	

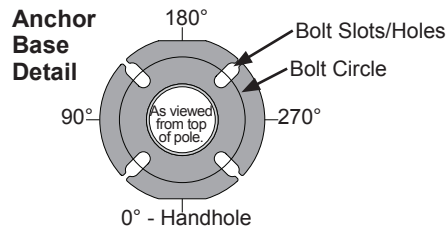

PRODUCT ORDERING CODE

MODEL	DESIGNATION	FIXTURE MOUNTING	FINISH SYSTEM	STANDARD COLOR OPTIONS	BASE COVER	ANCHOR BOLTS	SUPPLEMENTAL INFO
DS340	Select Correct Designation from the Load and Dimensional Data Chart.	Drill Mounting (See Orientation) D1 = (1) Drilling @ 270° D2 = (2) Drillings @ 90° & 270° D3 = (3) Drillings @ 0°, 120°, & 240° D4 = (4) Drillings @ 0°, 90°, 180°, & 270° D5 = (2) Drillings @ 90° & 180° D6 = (3) Drillings @ 90°, 180°, & 270° Tenon Mounting P2 = 2.38" OD x 4" tenon P4 = 4.00" OD x 6" tenon P5 = 2.88" OD x 4" tenon P6 = 2.88" OD x 5" tenon P7 = 2.38" OD x 5" tenon P9 = Special Size (Specify) Other Options PC = Pole Cap PL = Plain Top (No Cap)	GV = Galvanized FP = Finish Painted -----OPTIONAL----- FPGV = Finish Paint over Galvanizing VP30 = V-PRO™ 30 System VP32 = V-PRO™ 32 System VP53 = V-PRO™ 53 System VP54 = V-PRO™ 54 System VP57 = V-PRO™ 57 System VP100 = V-PRO™ 100 System VP105 = V-PRO™ 105 System	GV = Galvanized BK = Black DB = Dark Bronze MB = Medium Bronze WH = White LG = Light Gray CB = Bronze DG = Dark Green ST = Sandstone HG = Hunter Green SG = Slate Gray SL = Silver SC = Special Color (Specify)	FBC = Full Base Cover -----OPTIONAL----- DT = Round Dart Cover	AB = With Anchor Bolts LAB = Without Anchor Bolts	

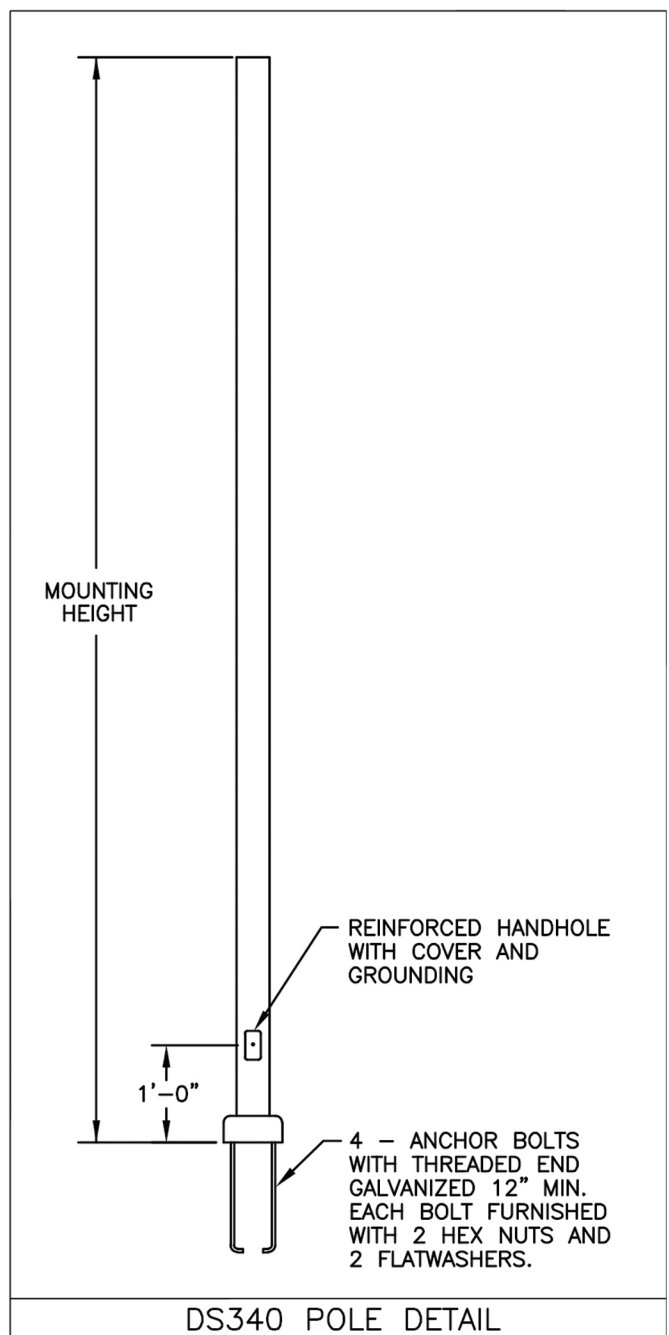
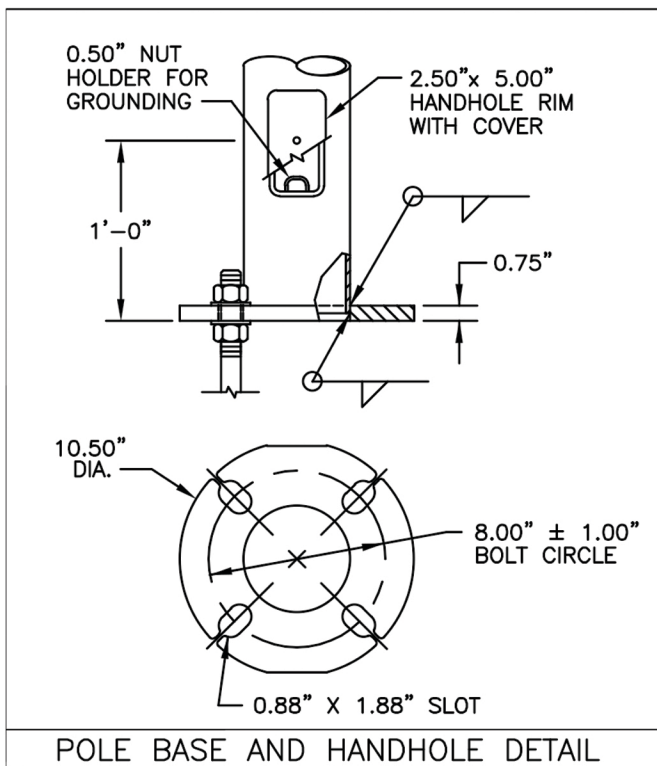
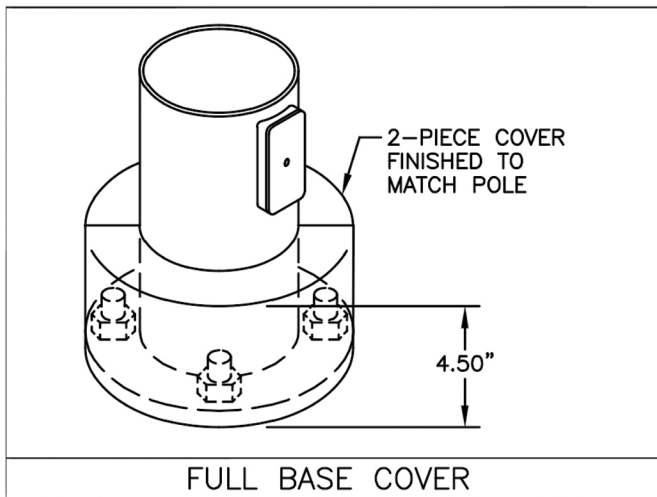
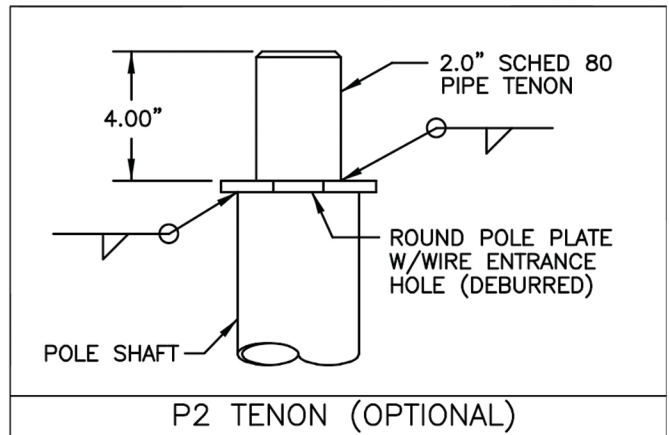
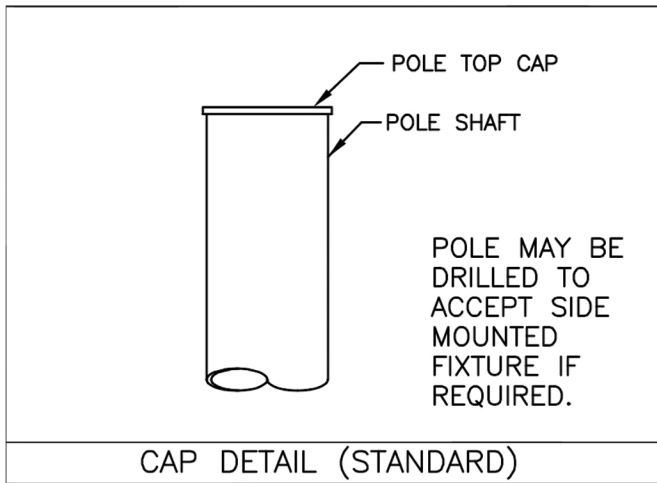

SFC7205 03/16 valmontstructures.com carries the most current spec information and supersedes these guidelines.