

**City of Portland, Maine - Building or Use Permit Application**

389 Congress Street, 04101 Tel: (207) 874-8703, Fax: (207) 874-8716

Permit No: 08-1300	Issue Date:	CBI: 111 A016002
-----------------------	-------------	---------------------

Location of Construction: 449 FOREST AVE	Owner Name: FOREST AVENUE PLAZA LLC	Owner Address: 715 BOYLSTON ST	Phone:
Business Name:	Contractor Name: Grover Contracting	Contractor Address: 51 Burnham Drive Naples	Phone: 2075777282
Lessee/Buyer's Name	Phone:	Permit Type: HVAC	Zone: B-2b

Past Use: Commercial - "Wash Tub II"	Proposed Use: Commercial - "Wash Tub II" - install a NATCO Boiler in back rt corner	Permit Fee: \$160.00	Cost of Work: \$13,300.00	CEO District: I
		FIRE DEPT: <input checked="" type="checkbox"/> Approved <input type="checkbox"/> Denied <i>See conditions</i>	INSPECTION: Use Group: <input checked="" type="checkbox"/> Type: <i>HVAC</i> <i>State Gas Reg's</i>	

Proposed Project Description: install a NATCO Boiler in back rt corner	Signature: <i>Leroy Coag</i>	Signature: <i>[Signature]</i>
PEDESTRIAN ACTIVITIES DISTRICT (P.A.D.)		
Action: <input type="checkbox"/> Approved <input type="checkbox"/> Approved w/Conditions <input type="checkbox"/> Denied		
Signature:		Date:

Permit Taken By: Idobson	Date Applied For: 10/14/2008	<b>Zoning Approval</b>
-----------------------------	---------------------------------	------------------------

- This permit application does not preclude the Applicant(s) from meeting applicable State and Federal Rules.
- Building permits do not include plumbing, septic or electrical work.
- Building permits are void if work is not started within six (6) months of the date of issuance. False information may invalidate a building permit and stop all work..

<b>Special Zone or Reviews</b> <input type="checkbox"/> Shoreland <input type="checkbox"/> Wetland <input type="checkbox"/> Flood Zone <input type="checkbox"/> Subdivision <input type="checkbox"/> Site Plan Maj <input type="checkbox"/> Minor <input type="checkbox"/> MM <input type="checkbox"/> Date: <i>10/14/08</i>	<b>Zoning Appeal</b> <input type="checkbox"/> Variance <input type="checkbox"/> Miscellaneous <input type="checkbox"/> Conditional Use <input type="checkbox"/> Interpretation <input type="checkbox"/> Approved <input type="checkbox"/> Denied Date:	<b>Historic Preservation</b> <input checked="" type="checkbox"/> Not in District or Landmark <input type="checkbox"/> Does Not Require Review <input type="checkbox"/> Requires Review <input type="checkbox"/> Approved <input type="checkbox"/> Approved w/Conditions <input type="checkbox"/> Denied Date:
---	---	--

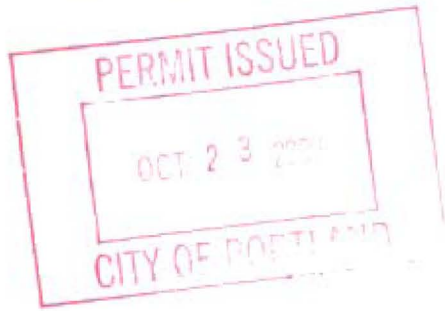

**CERTIFICATION**

I hereby certify that I am the owner of record of the named property, or that the proposed work is authorized by the owner of record and that I have been authorized by the owner to make this application as his authorized agent and I agree to conform to all applicable laws of this jurisdiction. In addition, if a permit for work described in the application is issued, I certify that the code official's authorized representative shall have the authority to enter all areas covered by such permit at any reasonable hour to enforce the provision of the code(s) applicable to such permit.



**CITY OF PORTLAND, MAINE**  
Department of Building Inspections

**Original Receipt**

10/14/08

Received from Jeffrey Grover

Location of Work 445 Forest Ave

Cost of Construction \$ 13,300 Building Fee: \_\_\_\_\_

Permit Fee \$ \_\_\_\_\_ Site Fee: \_\_\_\_\_

Certificate of Occupancy Fee: \_\_\_\_\_

**Total:** 160

Building (I1) \_\_\_\_\_ Plumbing (I5) \_\_\_\_\_ Electrical (I2) \_\_\_\_\_ Site Plan (U2) \_\_\_\_\_

Other \_\_\_\_\_

CBL: 111 A 16

Check #: \_\_\_\_\_ **Total Collected \$** 160

**No work is to be started until permit issued.**

If permit is Withdrawn or Denied, amount of the Refund is based on \$20.00 or 20% of the fee, (whichever is greater)

In order to receive a refund, you MUST present the Original Receipt.

Taken by: [Signature]

WHITE - Applicant's Copy  
YELLOW - Office Copy  
PINK - Permit Copy

**City of Portland, Maine - Building or Use Permit**

389 Congress Street, 04101 Tel: (207) 874-8703, Fax: (207) 874-8716

Permit No: 08-1300	Date Applied For: 10/14/2008	CBL: 111 A016002
-----------------------	---------------------------------	---------------------

Location of Construction: 449 FOREST AVE	Owner Name: FOREST AVENUE PLAZA LLC	Owner Address: 715 BOYLSTON ST	Phone:
Business Name:	Contractor Name: Grover Contracting	Contractor Address: 51 Burnham Drive Naples	Phone: (207) 577-7282
Lessee/Buyer's Name	Phone:	Permit Type: HVAC	

Proposed Use: Commercial - "Wash Tub II" - install a NATCO Boiler in back rt corner	Proposed Project Description: install a NATCO Boiler in back rt corner
--	---

**Dept:** Zoning      **Status:** Approved with Conditions      **Reviewer:** Marge Schmuckal      **Approval Date:** 10/14/2008

**Note:** **Ok to Issue:** ✓

- 1) This permit is being approved on the basis of plans submitted. Any deviations shall require a separate approval before starting that work. Based on the application, it is assumed that this new boiler is being replaced entirely within the existing building.

**Dept:** Building      **Status:** Approved with Conditions      **Reviewer:** Tammy Munson      **Approval Date:** 10/23/2008

**Note:** **Ok to Issue:** ✓

- 1) The installation must comply with the State of Maine Gas Regulations.

**Dept:** Fire      **Status:** Approved with Conditions      **Reviewer:** Capt Greg Cass      **Approval Date:** 10/17/2008

**Note:** **Ok to Issue:** ✓

- 1) No manufacturers specs provided.  
System shall be vented, clearances to unit shall be maintained.



FILL IN AND SIGN WITH INK

# APPLICATION FOR PERMIT HEATING OR POWER EQUIPMENT

PERMIT ISSUED  
OCT 2 2008  
CITY OF PORTLAND

To the INSPECTOR OF BUILDINGS, PORTLAND, ME.

The undersigned hereby applies for a permit to install the following heating, cooking or power equipment in accordance with the Laws of Maine, the Building Code of the City of Portland, and the following specifications:

Location / CBL 449 FOREST AVE Use of Building LAUNDRY Date 10-14-08  
Name and address of owner of appliance KEVIN & DEBBIE CURCO  
715 BOYLSTON ST.  
Installer's name and address GROVER CONTRACTING  
Telephone 207-577-7282

### Location of appliance:

- Basement
- Floor Back R+ corner
- Attic
- Roof

### Type of Fuel:

- Gas
- Oil
- Solid

Appliance Name: NATCO Boiler

U.L. Approved  Yes  No

Will appliance be installed in accordance with the manufacture's installation instructions?  Yes  No

IF NO Explain: \_\_\_\_\_

### The Type of License of Installer:

- Master Plumber # \_\_\_\_\_
- Solid Fuel # \_\_\_\_\_
- Oil # \_\_\_\_\_
- Gas # PNT3882
- Other \_\_\_\_\_

### Type of Chimney:

- Masonry Lined  
Factory built \_\_\_\_\_
- Metal  
Factory Built U.L. Listing # \_\_\_\_\_
- Direct Vent  
Type \_\_\_\_\_ UL# \_\_\_\_\_

### Type of Fuel Tank

- Oil
- Gas NAT 10/14/08

Size of Tank \_\_\_\_\_

Number of Tanks \_\_\_\_\_

Distance from Tank to Center of Flame \_\_\_\_\_ feet.

Cost of Work: \$ 13,300

Permit Fee: \$ 160

### Approved

Fire: \_\_\_\_\_  
Etc.: \_\_\_\_\_  
Bldg.: \_\_\_\_\_

### Approved with Conditions

- See attached letter or requirement

Signature of Installer \_\_\_\_\_

Inspector's Signature

Date Approved

# Installation and Operating Instructions for **Natco Fire Coil**

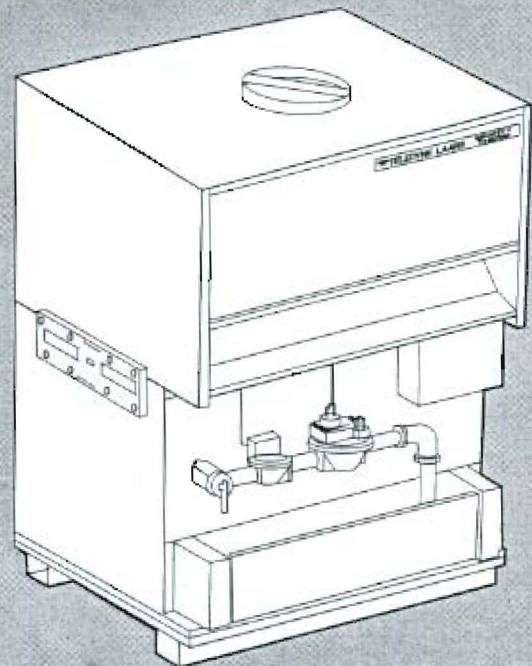
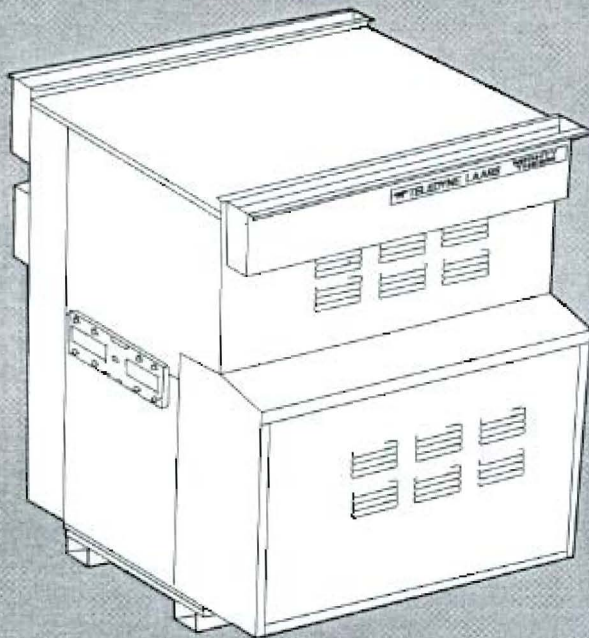

**Models  
VW, PW and IW**  
Volume Water Heaters  
Sizes 500-1825



These instructions are to be stored in the pocket provided on the boiler.

## FOR YOUR SAFETY

Do not store or use gasoline or other flammable vapors and liquids in the vicinity of this or any other appliance.

## WARNING

Improper installation, adjustment, alteration, service or maintenance can cause injury or property damage. Refer to this manual. For assistance or additional information consult a qualified installer, service agency or the gas supplier.

## FOR YOUR SAFETY - WHAT TO DO IF YOU SMELL GAS

- Do not try to light any appliance.
- Do not touch any electrical switch; do not use any phone in your building.
- Immediately call your gas supplier from a neighbor's telephone. Follow the gas supplier's information.
- If you cannot reach your gas supplier, call the fire department.

MOD VW0500iNO9K1ACNA

Ser COB198967

NAT

