

**City of Portland, Maine - Building or Use Permit Application**

389 Congress Street, 04101 Tel: (207) 874-8703, Fax: (207) 874-8716

Permit No: 08-1300	Issue Date:	CBL: 111 A016002
-----------------------	-------------	---------------------

Location of Construction: 449 FOREST AVE	Owner Name: FOREST AVENUE PLAZA LLC	Owner Address: 715 BOYLSTON ST	Phone:
Business Name:	Contractor Name: Grover Contracting	Contractor Address: 51 Burnham Drive Naples	Phone 2075777282
Lessee/Buyer's Name	Phone:	Permit Type: HVAC	Zone: B-2h

Past Use: Commercial - "Wash Tub II"	Proposed Use: Commercial - "Wash Tub II" - install a NATCO Boiler in back rt corner	Permit Fee: \$160.00	Cost of Work: \$13,300.00	CEO District: I
		FIRE DEPT: <input checked="" type="checkbox"/> Approved <input type="checkbox"/> Denied <i>See conditions</i>	INSPECTION: Use Group: <i>U</i> Type: <i>HWAC</i> <i>State Gas Reg's</i>	

Proposed Project Description: install a NATCO Boiler in back rt corner	Signature: <i>Greg Cass</i>	Signature: <i>[Signature]</i>
PEDESTRIAN ACTIVITIES DISTRICT (P.A.D.)		
Action: <input type="checkbox"/> Approved <input type="checkbox"/> Approved w/Conditions <input type="checkbox"/> Denied		
Signature:		Date:

Permit Taken By: Idobson	Date Applied For: 10/14/2008	<b>Zoning Approval</b>
-----------------------------	---------------------------------	------------------------

- This permit application does not preclude the Applicant(s) from meeting applicable State and Federal Rules.
- Building permits do not include plumbing, septic or electrical work.
- Building permits are void if work is not started within six (6) months of the date of issuance. False information may invalidate a building permit and stop all work..

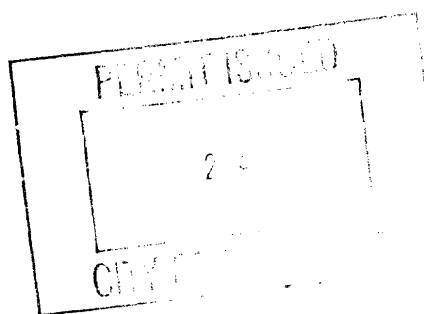

Special Zone or Reviews	Zoning Appeal	Historic Preservation
<input type="checkbox"/> Shoreland	<input type="checkbox"/> Variance	<input checked="" type="checkbox"/> Not in District or Landmark
<input type="checkbox"/> Wetland	<input type="checkbox"/> Miscellaneous	<input type="checkbox"/> Does Not Require Review
<input type="checkbox"/> Flood Zone	<input type="checkbox"/> Conditional Use	<input type="checkbox"/> Requires Review
<input type="checkbox"/> Subdivision	<input type="checkbox"/> Interpretation	<input type="checkbox"/> Approved
<input type="checkbox"/> Site Plan	<input type="checkbox"/> Approved	<input type="checkbox"/> Approved w/Conditions
Maj <input type="checkbox"/> Minor <input type="checkbox"/> MM <input type="checkbox"/>	<input type="checkbox"/> Denied	<input type="checkbox"/> Denied
Date: <i>10/14/08</i>	Date:	Date:

**CERTIFICATION**

I hereby certify that I am the owner of record of the named property, or that the proposed work is authorized by the owner of record and that I have been authorized by the owner to make this application as his authorized agent and I agree to conform to all applicable laws of this jurisdiction. In addition, if a permit for work described in the application is issued, I certify that the code official's authorized representative shall have the authority to enter all areas covered by such permit at any reasonable hour to enforce the provision of the code(s) applicable to such permit.

\_\_\_\_\_  
SIGNATURE OF APPLICANT ADDRESS DATE PHONE

\_\_\_\_\_  
RESPONSIBLE PERSON IN CHARGE OF WORK, TITLE DATE PHONE

**City of Portland, Maine - Building or Use Permit**

389 Congress Street, 04101 Tel: (207) 874-8703, Fax: (207) 874-8716

<b>Permit No:</b> 08-1300	<b>Date Applied For:</b> 10/14/2008	<b>CBL:</b> 111 A016002
------------------------------	--	----------------------------

<b>Location of Construction:</b> 449 FOREST AVE	<b>Owner Name:</b> FOREST AVENUE PLAZA LLC	<b>Owner Address:</b> 715 BOYLSTON ST	<b>Phone:</b>
<b>Business Name:</b>	<b>Contractor Name:</b> Grover Contracting	<b>Contractor Address:</b> 51 Burnham Drive Naples	<b>Phone</b> (207) 577-7282
<b>Lessee/Buyer's Name</b>	<b>Phone:</b>	<b>Permit Type:</b> HVAC	

<b>Proposed Use:</b> Commercial - "Wash Tub II" - install a NATCO Boiler in back rt corner	<b>Proposed Project Description:</b> install a NATCO Boiler in back rt corner
---	--

**Dept:** Zoning      **Status:** Approved with Conditions      **Reviewer:** Marge Schmuckal      **Approval Date:** 10/14/2008

**Note:** **Ok to Issue:**

- 1) This permit is being approved on the basis of plans submitted. Any deviations shall require a separate approval before starting that work. Based on the application, it is assumed that this new boiler is being replaced entirely within the existing building.

**Dept:** Building      **Status:** Approved with Conditions      **Reviewer:** Tammy Munson      **Approval Date:** 10/23/2008

**Note:** **Ok to Issue:**

- 1) The installation must comply with the State of Maine Gas Regulations.

**Dept:** Fire      **Status:** Approved with Conditions      **Reviewer:** Capt Greg Cass      **Approval Date:** 10/17/2008

**Note:** **Ok to Issue:**

- 1) No manufactors spec.s provided.  
System shall be vented, clearances to unit shall be maintained.



FILL IN AND SIGN WITH INK

# APPLICATION FOR PERMIT HEATING OR POWER EQUIPMENT

To the INSPECTOR OF BUILDINGS, PORTLAND, ME.

The undersigned hereby applies for a permit to install the following heating, cooking or power equipment in accordance with the Laws of Maine, the Building Code of the City of Portland, and the following specifications:

Location / CBL 449 FOREST AVE Use of Building LAUNDRY Date 10-14-08  
 Name and address of owner of appliance KEVIN & DEBBIE CURCO  
715 BOYLSTON ST.  
 Installer's name and address GROVER CONTRACTING  
 Telephone 207-577-7282

### Location of appliance:

- Basement
- Floor Back R+ Corner
- Attic
- Roof

### Type of Fuel:

- Gas
- Oil
- Solid

Appliance Name: NATCO boiler

U.L. Approved  Yes  No

Will appliance be installed in accordance with the manufacture's installation instructions?  Yes  No

IF NO Explain: \_\_\_\_\_

### Type of Chimney:

- Masonry Lined  
Factory built \_\_\_\_\_
- Metal  
Factory Built U.L. Listing # \_\_\_\_\_
- Direct Vent  
Type \_\_\_\_\_ UL# \_\_\_\_\_

### Type of Fuel Tank:

None

0/14/08

### The Type of License of Installer:

- Master Plumber # \_\_\_\_\_
- Solid Fuel # \_\_\_\_\_
- Oil # \_\_\_\_\_
- Gas # PNT 3882
- Other \_\_\_\_\_

\_\_\_\_\_ feet.

### Approved

### Approved with Conditions

Fire: \_\_\_\_\_  
 Ele.: \_\_\_\_\_  
 Bldg.: \_\_\_\_\_

See attached letter or requirement

Signature of Installer \_\_\_\_\_ Inspector's Signature \_\_\_\_\_ Date Approved \_\_\_\_\_

# Installation and Operating Instructions for Natco Fire Coil

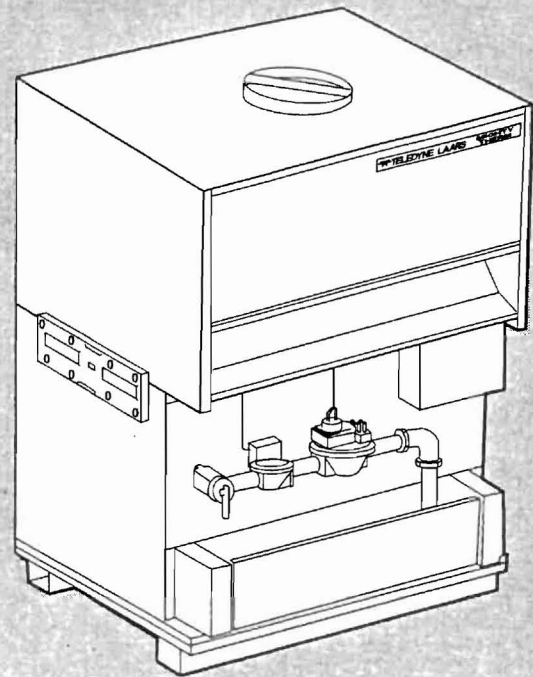
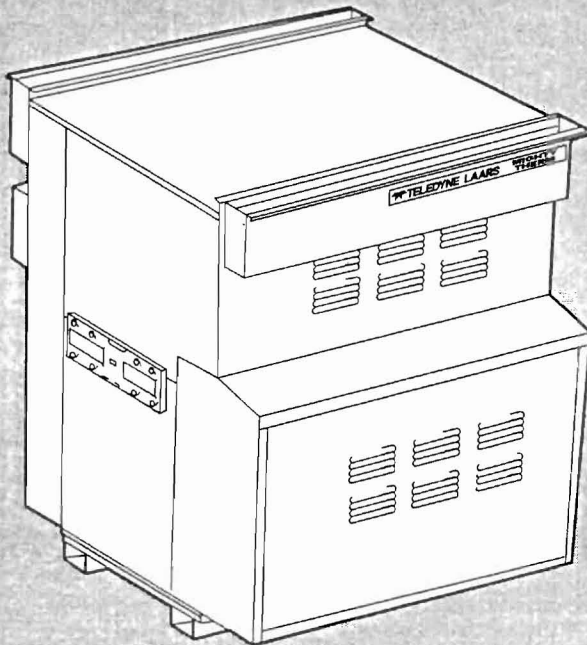

## Models VW, PW and IW Volume Water Heaters Sizes 500-1825



These instructions are to be stored in the pocket provided on the boiler.

### FOR YOUR SAFETY

Do not store or use gasoline or other flammable vapors and liquids in the vicinity of this or any other appliance.

### WARNING

Improper installation, adjustment, alteration, service or maintenance can cause injury or property damage. Refer to this manual. For assistance or additional information consult a qualified installer, service agency or the gas supplier.

### FOR YOUR SAFETY - WHAT TO DO IF YOU SMELL GAS

- Do not try to light any appliance.
- Do not touch any electrical switch; do not use any phone in your building.
- Immediately call your gas supplier from a neighbor's telephone. Follow the gas supplier's information.
- If you cannot reach your gas supplier, call the fire department.

MOB VU 3500 INO 9K H.C.M.A

SER C 23 18 6 9 6 7

NAT



H2107400A

**NATGO**

National Combustion Company, Inc.  
104-07 180<sup>th</sup> Street, Jamaica, NY 11433 • (718) 291-8400 FAX (718) 291-6870  
Litho in U.S.A. © 0610