

**City of Portland, Maine - Building or Use Permit Application**

389 Congress Street, 04101 Tel: (207) 874-8703, Fax: (207) 874-8716

Permit No: 10-0263	Issue Date:	CBL: 111 C009001
-----------------------	-------------	---------------------

Location of Construction: 31 BELMEADE RD	Owner Name: MCGOVERN CHRISTINA L & D	Owner Address: 31 BELMEADE RD	Phone:
Business Name:	Contractor Name: Glen Dupuis	Contractor Address: P.O. Box 810 Biddeford	Phone: 2074235773
Lessee/Buyer's Name	Phone:	Permit Type: HVAC	Zone: R-5

Past Use: Single Family Home	Proposed Use: Single Family Home - install a Viessmann Vitodens wall mounted, gas fired condensing boiler	Permit Fee: \$120.00	Cost of Work: \$10,000.00	CEO District: 1
Proposed Project Description: install a Viessmann Vitodens wall mounted, gas fired condensing boiler		FIRE DEPT: <input type="checkbox"/> Approved <input type="checkbox"/> Denied <i>N/A</i>	INSPECTION: Use Group: <i>U</i> Type: <i>HVAC</i> <i>State Gas Regs</i>	

Signature:	Signature:
PEDESTRIAN ACTIVITIES DISTRICT (P.A.D.)	
Action: <input type="checkbox"/> Approved <input type="checkbox"/> Approved w/Conditions <input type="checkbox"/> Denied	
Signature:	Date:

Permit Taken By: ldobson	Date Applied For: 03/18/2010	<b>Zoning Approval</b>	
-----------------------------	---------------------------------	------------------------	--

<p>1. This permit application does not preclude the Applicant(s) from meeting applicable State and Federal Rules.</p> <p>2. Building permits do not include plumbing, septic or electrical work.</p> <p>3. Building permits are void if work is not started within six (6) months of the date of issuance. False information may invalidate a building permit and stop all work..</p>	<p>Special Zone or Reviews</p> <p><input type="checkbox"/> Shoreland</p> <p><input type="checkbox"/> Wetland</p> <p><input type="checkbox"/> Flood Zone</p> <p><input type="checkbox"/> Subdivision</p> <p><input type="checkbox"/> Site Plan</p> <p>Maj <input type="checkbox"/> Minor <input type="checkbox"/> MM <input type="checkbox"/></p> <p><i>OK w/condition</i> Date: 3/18/10 <i>AGN</i></p>	<p>Zoning Appeal</p> <p><input type="checkbox"/> Variance</p> <p><input type="checkbox"/> Miscellaneous</p> <p><input type="checkbox"/> Conditional Use</p> <p><input type="checkbox"/> Interpretation</p> <p><input type="checkbox"/> Approved</p> <p><input type="checkbox"/> Denied</p> <p>Date:</p>	<p>Historic Preservation</p> <p><input checked="" type="checkbox"/> Not in District or Landmark</p> <p><input type="checkbox"/> Does Not Require Review</p> <p><input type="checkbox"/> Requires Review</p> <p><input type="checkbox"/> Approved</p> <p><input type="checkbox"/> Approved w/Conditions</p> <p><input type="checkbox"/> Denied</p> <p>Date: <i>AGN</i></p>
---	--	---	---

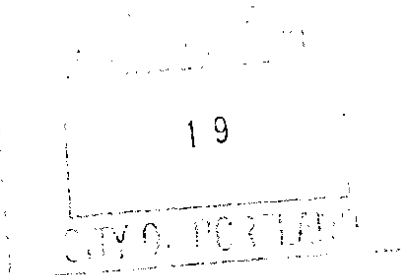

**CERTIFICATION**

I hereby certify that I am the owner of record of the named property, or that the proposed work is authorized by the owner of record and that I have been authorized by the owner to make this application as his authorized agent and I agree to conform to all applicable laws of this jurisdiction. In addition, if a permit for work described in the application is issued, I certify that the code official's authorized representative shall have the authority to enter all areas covered by such permit at any reasonable hour to enforce the provision of the code(s) applicable to such permit.

SIGNATURE OF APPLICANT	ADDRESS	DATE	PHONE
RESPONSIBLE PERSON IN CHARGE OF WORK, TITLE		DATE	PHONE

**City of Portland, Maine - Building or Use Permit**

389 Congress Street, 04101 Tel: (207) 874-8703, Fax: (207) 874-8716

Permit No: 10-0263	Date Applied For: 03/18/2010	CBL: 111 C009001
-----------------------	---------------------------------	---------------------

Location of Construction: 31 BELMEADE RD	Owner Name: MCGOVERN CHRISTINA L & D	Owner Address: 31 BELMEADE RD	Phone:
Business Name:	Contractor Name: Glen Dupuis	Contractor Address: P.O. Box 810 Biddeford	Phone (207) 423-5773
Lessee/Buyer's Name	Phone:	Permit Type: HVAC	

Proposed Use: Single Family Home - install a Viessmann Vitodens wall mounted, gas fired condensing boiler	Proposed Project Description: install a Viessmann Vitodens wall mounted, gas fired condensing boiler
--	---

Dept: Zoning	Status: Approved with Conditions	Reviewer: Ann Machado	Approval Date: 03/18/2010
Note:	Ok to Issue: <input checked="" type="checkbox"/>		
1) This property shall remain a single family dwelling. Any change of use shall require a separate permit application for review and approval.			
Dept: Building	Status: Approved with Conditions	Reviewer: Tammy Munson	Approval Date: 03/19/2010
Note:	Ok to Issue: <input checked="" type="checkbox"/>		
1) The installation must comply with the State of Maine Gas Regulations.			

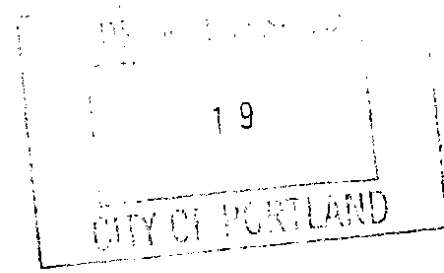

**BUILDING PERMIT INSPECTION PROCEDURES**

**Please call 874-8703 or 874-8693 (ONLY )**

**to schedule your inspections as agreed upon**

**Permits expire in 6 months, if the project is not started or ceases for 6 months.**

The Owner or their designee is required to notify the inspections office for the following inspections and provide adequate notice. Notice must be called in 48-72 hours in advance in order to schedule an inspection:

**By initializing at each inspection time, you are agreeing that you understand the inspection procedure and additional fees from a "Stop Work Order" and "Stop Work Order Release" will be incurred if the procedure is not followed as stated below.**

**A Pre-construction Meeting will take place upon receipt of your building permit.**

  X   **Final inspection required at completion of work.**

Certificate of Occupancy is not required for certain projects. Your inspector can advise you if your project requires a Certificate of Occupancy. All projects DO require a final inspection.

**If any of the inspections do not occur, the project cannot go on to the next phase, REGARDLESS OF THE NOTICE OR CIRCUMSTANCES.**

**CERIFICATE OF OCCUPANICES MUST BE ISSUED AND PAID FOR, BEFORE THE SPACE MAY BE OCCUPIED.**

\_\_\_\_\_  
Signature of Applicant/Designee

\_\_\_\_\_  
Date

\_\_\_\_\_  
Signature of Inspections Official

\_\_\_\_\_  
Date

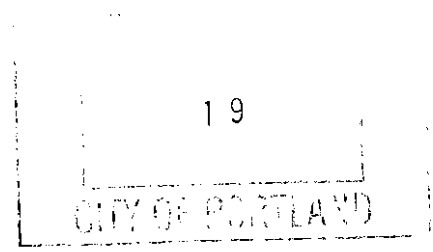



FILL IN AND SIGN WITH INK

# APPLICATION FOR PERMIT HEATING OR POWER EQUIPMENT

19

CITY OF PORTLAND

To the INSPECTOR OF BUILDINGS, PORTLAND, ME.

The undersigned hereby applies for a permit to install the following heating, cooking or power equipment in accordance with the Laws of Maine, the Building Code of the City of Portland, and the following specifications:

Location / CBL Portland Use of Building Residence Date 3/17/10  
 Name and address of owner of appliance Darren M<sup>c</sup>Govern  
31 Belmeade Rd  
 Installer's name and address Glenn Dupuis  
P.O. Box 810 Biddeford Me. 04005 Telephone (207) 423-5773

**Location of appliance:**

- Basement
- Attic
- Floor
- Roof

**Type of Fuel:**

- Gas
- Oil
- Solid

Appliance Name: Viessmann Vitodens 100-w  
 U.L. Approved  Yes  No

Will appliance be installed in accordance with the manufacture's installation instructions?  Yes  No

IF NO Explain: **RECEIVED**  
 MAR 17 2010

**The Type of License of Installer:**

- Master Plumber Dept. of Building Inspections
- Solid Fuel # City of Portland Maine
- Oil # \_\_\_\_\_
- Gas # PNT 21602
- Other \_\_\_\_\_

**Type of Chimney:**

- Masonry Lined  
Factory built \_\_\_\_\_
- Metal Plastic  
Factory Built U.L. Listing # ULC SC36
- Direct Vent  
Type \_\_\_\_\_ UL# \_\_\_\_\_

**Type of Fuel Tank**

- Oil
- Gas Natural Gas

Size of Tank N/A

Number of Tanks N/A

Distance from Tank to Center of Flame N/A feet.

Cost of Work: \$ \_\_\_\_\_

Permit Fee: \$ 120

**Approved**

**Approved with Conditions**

Fire: \_\_\_\_\_  
 Ele.: \_\_\_\_\_  
 Bldg.: \_\_\_\_\_

- See attached letter or requirement

Signature of Installer Glenn Dupuis

Inspector's Signature

Date Approved

# Installation and Service Instructions

for use by heating contractor

# VIESSMANN

Vitodens 100-W  
WB1B Series  
Wall-mounted, gas-fired condensing boiler

Heating input 37 to 118 MBH  
10.8 to 34.5 kW

Please file in Service Binder

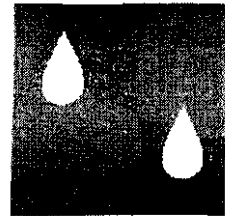

## VITODENS 100-W®

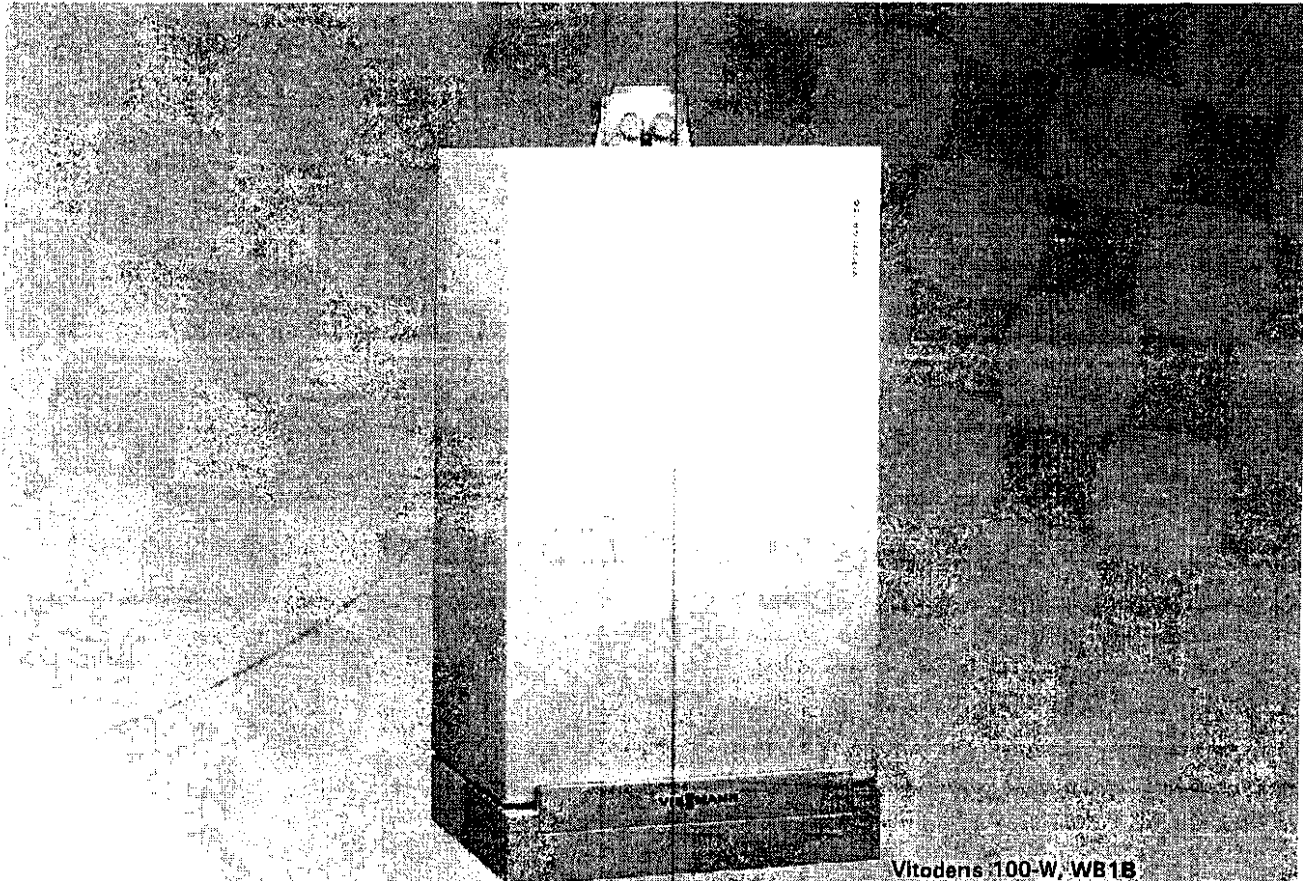

Vitodens 100-W, WB1B  
(with preinstalled coaxial vent pipe adaptor)



### IMPORTANT

Read and save these instructions for future reference.

## General Information/Set-up

### Before Set-up

Before placing boiler in its installation location, ensure all necessary accessories are installed.

#### CAUTION

The boiler must be installed in such a way that gas ignition system components are protected from water (spraying, splashing, etc.) during boiler operation and service.

### Minimum Clearances

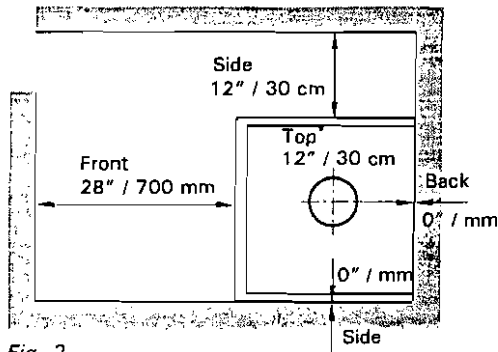

Fig. 2

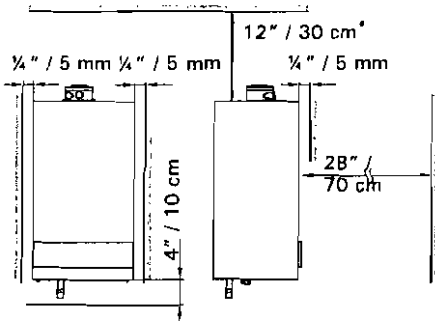

Fig. 3

#### Recommended minimum service clearances

Refer to Fig. 2 and 3.

#### Note:

The Vitodens 100-W boiler has passed the zero inches vent clearance to combustibles testing requirements dictated by the boiler Harmonized Standard ANSI Z21.13, CSA 4.9.2007 and therefore is listed for zero clearance to combustibles when vented with a single-wall special venting system (AL-29-4C material) or UL/ULC-listed CPVC gas vent material. The zero inches vent clearance to combustibles for the Vitodens 100-W boiler supercedes the clearance to combustibles listing that appears on the special venting system label.

Top clearance - 12" / 30 cm.



See the *Vitodens Venting System Installation Instructions*.

#### Clearance to combustibles

Top	Front	Rear	Left	Right	Vent pipe <sup>*1</sup>
0	0 AL, CL	0	0	0	0

AL = Alcove

CL = Closet

<sup>\*1</sup>Refer to the *Installation Instructions of the Vitodens Venting System* for details.

# MUGRO PP(s) Vent System, Configuration with Wall Terminal

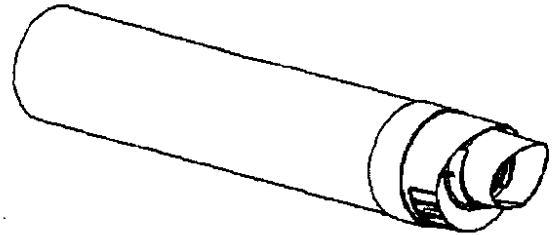

- Examine all components for possible shipping damage prior to installation;
- Proper joint assembly is essential for a safe installation. Read all instructions before beginning the installation and follow these instructions exactly as written.
- Check the integrity of joints upon completion of assembly;
- This venting system must be free to expand and contract under normal operation.
- This venting system must be supported in accordance with these instructions;
- Assure unrestricted vent movement where required through walls, ceilings and roof penetrations.
- Do not mix pipe, fittings, or joining methods from different vent system manufacturers. Do not use adhesives of any kind with this venting system.

Tested and  
listed to  
ULC S636  
(2008)  
by Intertek



Muelink & Grol

**Muelink & Grol B.V.**  
Duinkerkenstraat 27  
P.O. Box 509  
NL 9700 AM Groningen  
[www.muelink-grol.nl](http://www.muelink-grol.nl)  
date of issue: Dec. 2008