

## HANDRAIL DETAILS

NOTE: ALL RAILS FASTENED WITH 3" 316 SS SCREWS

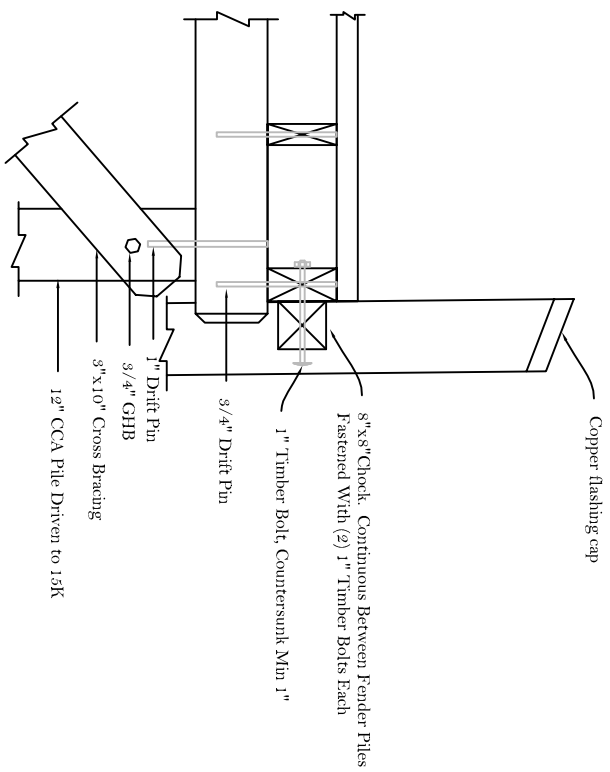

## PILE CAP/FENDER PILE DETAILS

Timber/Fastening Schedule						
Item	Dimensions	Grade	Treatment	Finish	Fastening	Notes
Piles	12" x 10"	12" Class B	2.5# CCA			Driven to 15K Capacity
Cross Bracing	3" x 10"	#2	6# ACQ	Rough	3/4" GHB	
Pile Caps	12" x 12"	#2	6# ACQ	Rough	1" x 20" Drift Pins	
Chocks	8" x 8"	#2	6# ACQ	Rough	3/4" Timber Bolts (2 per)	
Exterior Stringers	6" x 12"	#2	6# ACQ	Rough	3/4" x 20" Drift Pins	Max 24" Centers
Interior Stringers	4" x 12"	#2	6# ACQ	Rough	3/4" x 20" Drift Pins	Max 24" Centers
Decking	3" x 10"	#1	6# ACQ	S4S	3/8" x 8" Spikes (2/Com)	
Curb	8" x 8"	#1	6# ACQ	S4S	3/4" Timber Bolts	
Handrail Posts	4" x 6"	#1	6# ACQ	S4S	3/4" Timber Bolts	
Mid Rails	2" x 6"	#1	6# ACQ	S4S	3" 316 SS Screws	
Top Rail	5/4" x 6"		Composite	S4S	3" 316 SS Screws	

Note: All Fasteners Hot Dip Galvanized Unless Otherwise Noted

## Maritime

Construction and Engineering

Phone (207) 489-9831 Fax (207) 489-9834

Project: House Island

Dwg Name: Connection Details

Date Prepld 12/18/14

Scale

NTS