

**Submittal Data: 15RLS3
Inverter Driven Heat Pump**

15,000 BTU Heat-Pump System

Job Name: Jrefethen & Evergreen Improvement Assoc
 Location: 12 Jrefethen Ave Peaks Island
 Engineer: n/a
 Submitted to: City of Portland
 Submitted by: Joggen Energy
 Reference: n/a

Date: 3-10-15
 Approval: _____
 Construction: _____
 Unit #: _____
 Drawing #: _____

General Features

- Refrigerant Type R410A.
- Humidity Sensor
- Wired and wireless remote controllers
- Double swing automatic
- Automatic airflow adjustment
- Low noise mode
- Powerful mode
- 5- Years Parts, 7-Years Compressor Warranty (See Warranty Statement for details)
- Program timer
- Weekly time

Model Information

Outdoor..... AOU15RLS3
 Indoor..... ASU15RLS3

Electrical..... 208/230V AC 1ph-60Hz
 Available Voltage Range..... 208/230 +/- 10%
 Minimum Circuit Ampacity..... 17.2 A
 Max Fuse Size..... 20A
 Max Starting Current..... 5.2 A

Input Power
 Cooling..... 1.04 kW
 Heating..... 1.15 kW

Running Current
 Cooling..... 4.8 A
 Heating..... 5.2 A

Capacity
 Nominal Cooling..... 15,000 Btu
 Min-Max Cooling..... 3,100-18,400 Btu/h
 Nominal Heating..... 18,000 Btu/h
 Min-Max Heating..... 3,100-23,900 Btu/h

Compressor..... Rotary (inv x1)
 Motor Output..... 1,000 W
 Refrigerant..... R410a
 Charge..... 3 lbs. 1 oz
 Oil..... FREOL a68SZ

Fan Motor
 (Condenser) Type: DC..... Propeller x 1
 (Condenser) Motor Output..... 49 W
 (Evaporator) Type: DC..... Cross flow fan x1
 (Evaporator) Motor Output..... 61 W

Heat Exchanger {Condenser (C) Evaporator (E)}
 Dimensions (H x W x D)
 Condense..... 23-1/8 x 34-11/16 x 1-7/16 in. (588x881x36.4 mm)
 Evaporator..... Main 15-1/8 x 28-3/8 x 1-3/16 in. (384x720x30) Sub 3-5/16 x 28-3/8 x 1/2 in. (84x720x13.3 mm) 4-15/16 x 28-3/8 x 1/2 in. (126x720x13.3 mm)
 Fin Pitch..... 20 FPI (C) Main 21 FPI Sub 18 FPI (E)
 Rows x Stages..... 2 x 28 (C) Main 3 x 24 Sub 1 x 10 (E)
 Pipe Type (Material)..... Copper (C) Copper (E)
 Fin Type (Material)..... Aluminum (C) Aluminum (E)

Note: Specifications are based on the following conditions:
 Cooling: Indoor temperature of 80°F (26.7°C) DB/67°F (19.44°C) WB, and outdoor temperature of 95°F (35°C) DB/75°F (23.9°C) WB.
 Heating: Indoor temperature of 70°F (21.11°C) DB/59°F (15°C) WB, and outdoor temperature of 47°F (8.33°C) DB/43°F (6.11°C) WB.
 Pipe length: 24ft. 7in. (7.5m). Height difference: 0ft. (0m) (Outdoor unit - indoor unit)

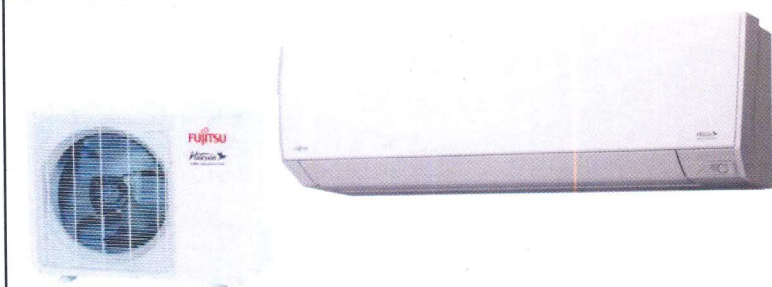

Operation Temperature Range

Cooling..... 14°F (-10°C) to 115°F (46°C)
 Heating..... -5°F (-21°C) to 75°F (24°C)

Efficiency

SEER..... 25.3
 EER (cooling)..... 4.09 kW/kW
 COP (heating)..... 4.59kW/kW / 15.7 Btu/hW
 HSPF (heating)..... 13.4 Btu/hW

Enclosure (Condenser)

Material..... Painted galvanized steel
 Color..... Beige (10 YR 7.5/1.0 NN)

Sound Pressure Level

Outdoor..... 49 dB(A)
 Indoor..... 45 dB(A)

Dimensions

H x W x D
 Outdoor in. (mm)..... 24-1/2 (620) x 31-1/8 (790) x 11-7/16 (290)
 Indoor in. (mm)..... 11-5/8 (295) x 37 (940) x 10-5/8 (270)

Connection Pipe

Liquid..... 1/4" / 6.35 mm Flare
 Gas..... 1/2" / 12.7 mm Flare
 Method (Liquid/Gas)..... Brazing
 Max Length (Pre-charge)..... 65 ft. (20 m) / (49 ft. {15 m})
 Max Height Difference..... 49 ft. (15 m)

Weight

Outdoor..... 86 lbs (39 kg)
 Indoor..... 31 lbs (14 kg)

Accessories

Wired Remote Controller..... UTY-RVNUM
 Wired Remote Controller..... UTY-RNNUM
 Simple Remote Controller..... UTY-RSNUM
 Communication Kit..... UTY-TWBXF1
 External Connection Kit..... UTY-XWZXZ5

Dimensions: 15RLS3

[Unit: in. (mm)]

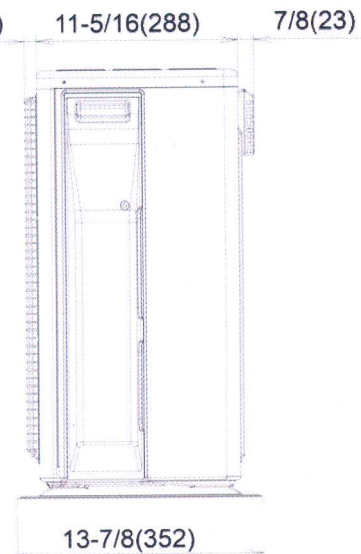
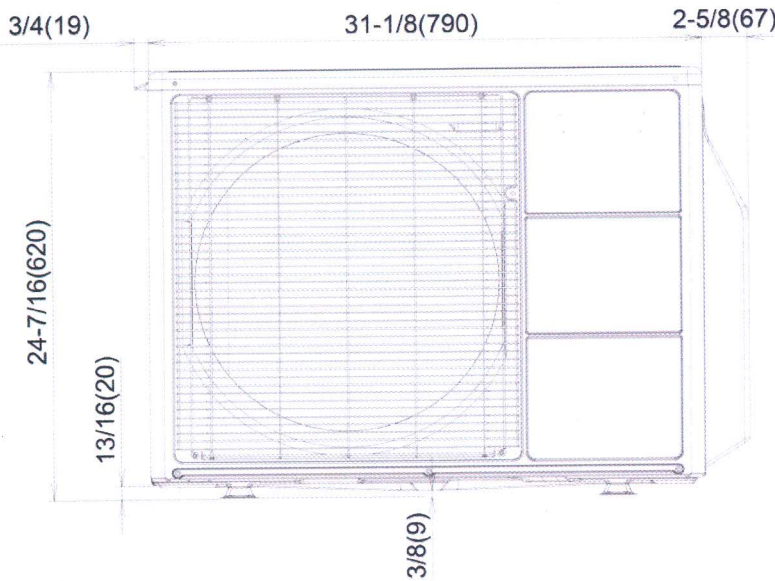
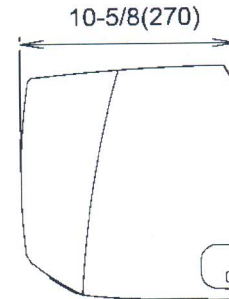
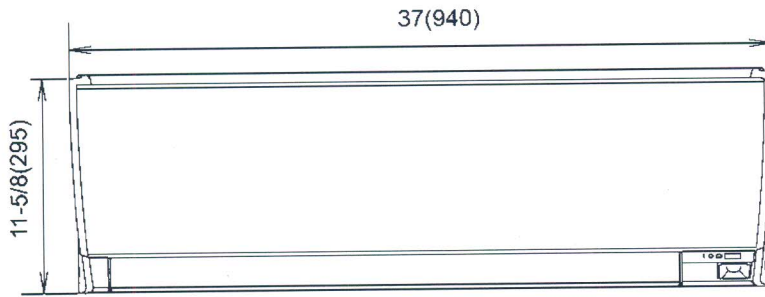

Front view

Side view

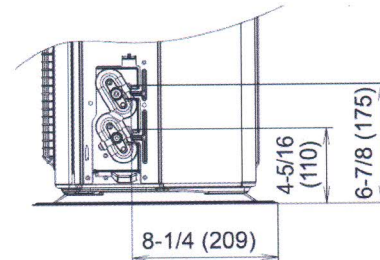
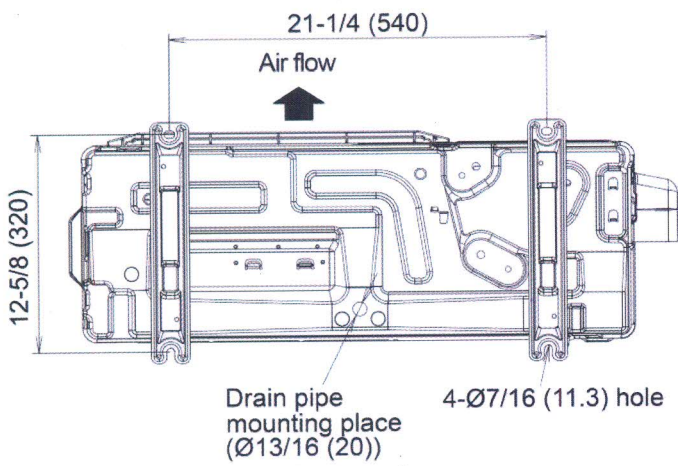

Bottom view