

A Proposed Second Floor Bath: South
 $\frac{1}{2}''=1'-0''$

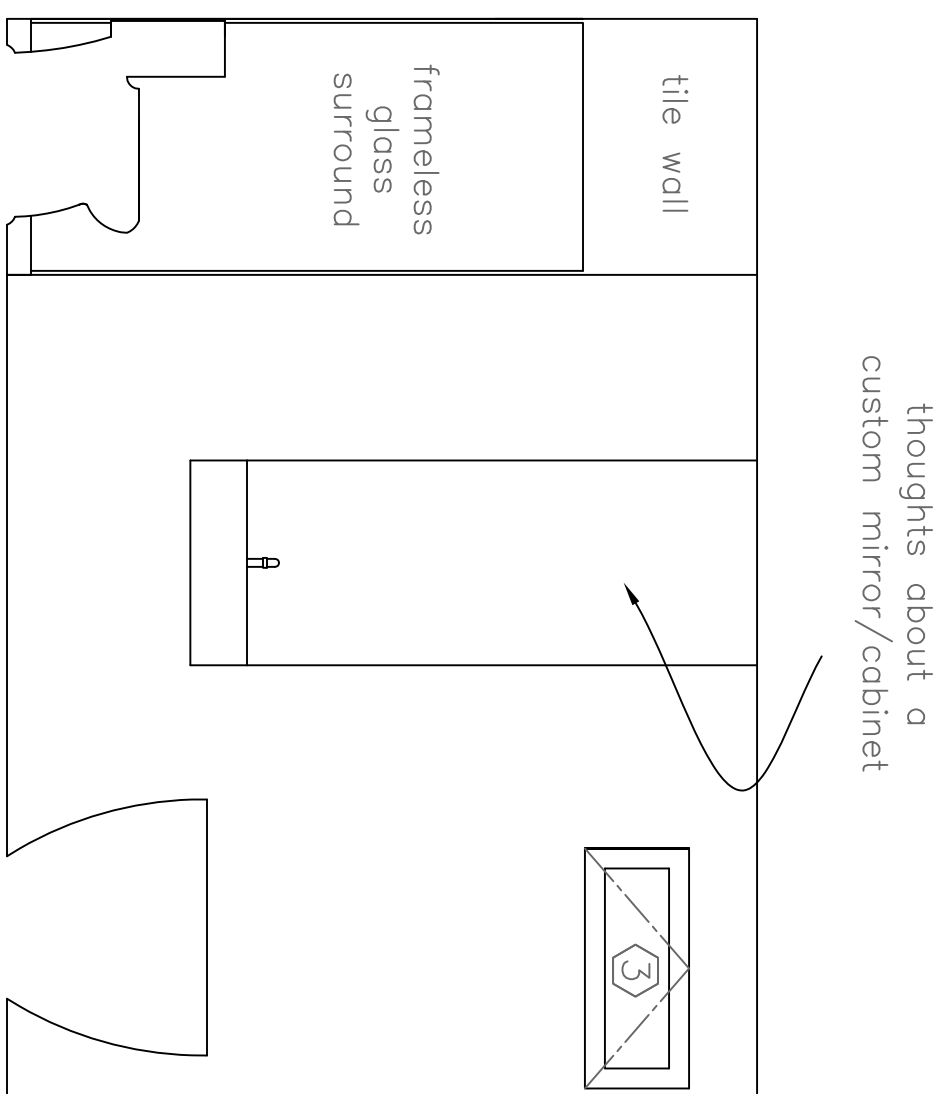

B Proposed Second Floor Bath: East
 $\frac{1}{2}''=1'-0''$

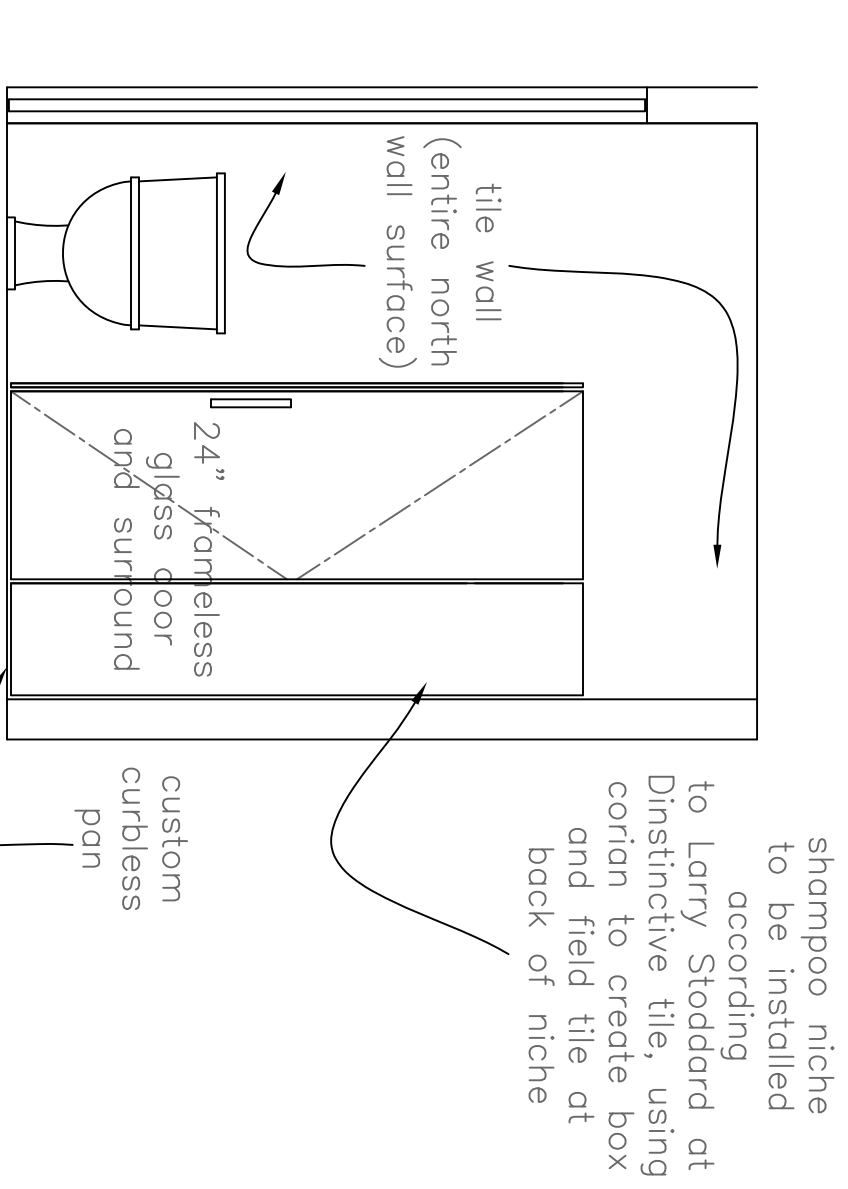

C Proposed Second Floor Bath: North
 $\frac{1}{2}''=1'-0''$

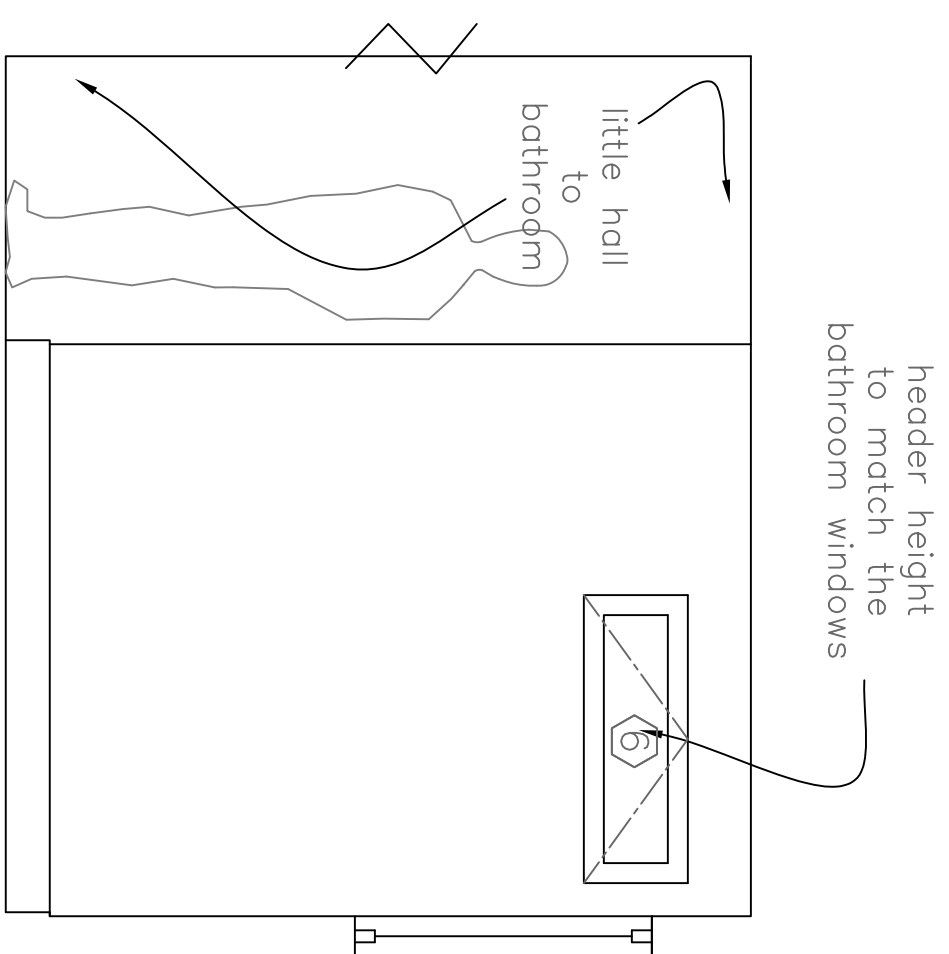

D Second Floor Foyer East Elevation: With High Horizontal Window
 $\frac{1}{2}''=1'-0''$

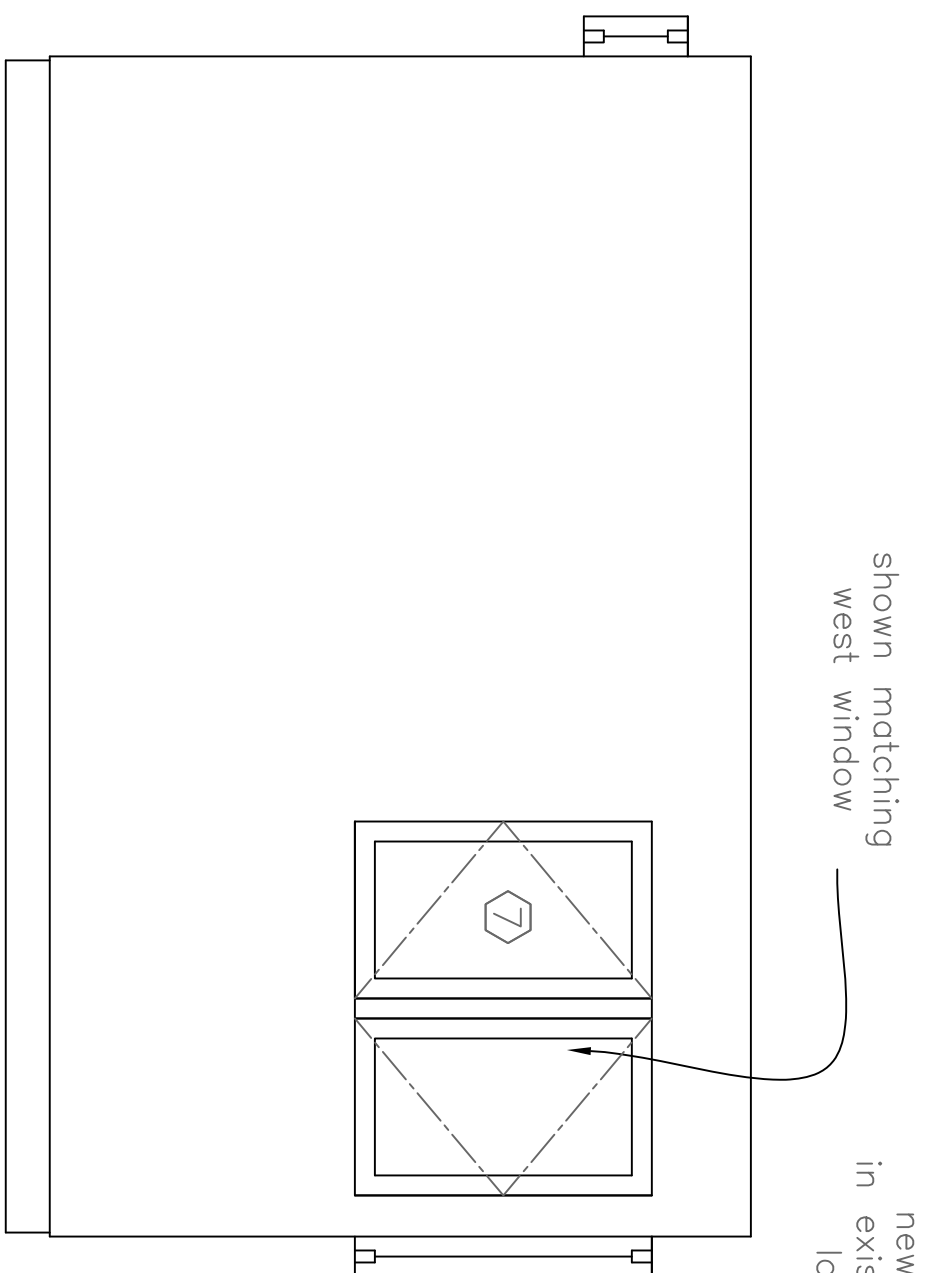

E Second Floor Foyer South Elevation: With Matching Corner Window
 $\frac{1}{2}''=1'-0''$

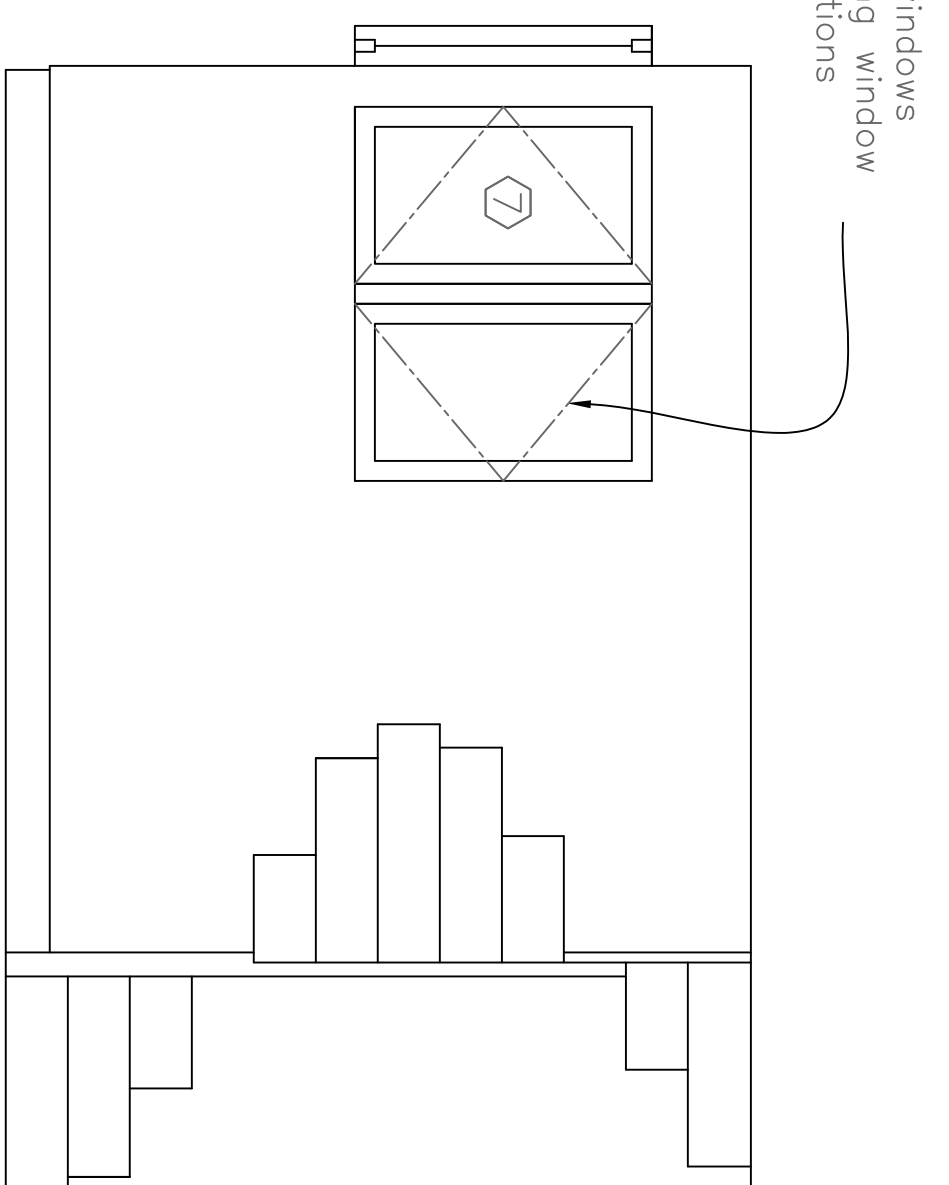

F Second Floor Foyer West Elevation: Existing Window Location
 $\frac{1}{2}''=1'-0''$

Rachel Conly
 Architectural Design
 26 Sterling Street
 Peaks Island, Maine 04108
 207.766.5625

Interiors

PROJECT
 Branson Residence
 5 Beach Road
 Peaks Island, Me.
 04108

DATE 5.9.14 REVISED
 SCALE $\frac{1}{2}''=1'-0''$ DRAWN BY Rachel
 NOTES