

DECK A  
 2x12 SPF#2 PERIMETER  
 2x12 SPF#2 MARRIAGE WALL PERIMETER  
 2x10 JOIST @ 16" O.C.  
 JOIST HANGERS WHERE SHOWN

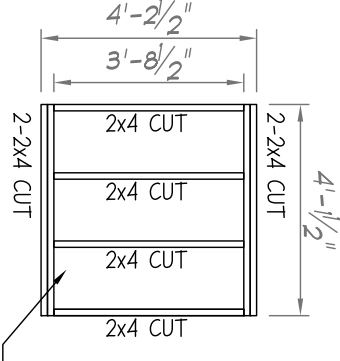

2x4 SPF @ 16" O.C. CUT 2x4 TO 3-1/4" FOR ELEVATOR PIT FILL IN (TEMP FLOOR)

3/4" T&G ADVANTECH  
 2x6 SPF @ 16" O.C. CUT  
 2x6 TO 5-1/4" FOR ELEVATOR PIT

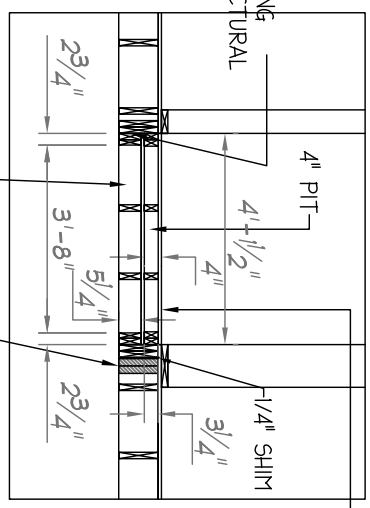

LAG TO SURROUNDING MEMBERS W/ STRUCTURAL SCREENS

3/4" T&G ADVANTECH  
 2x4 SPF @ 16" O.C. CUT 2x4 TO 3-1/4" FOR ELEVATOR PIT FILL IN (TEMP FLOOR)

NOTE ANY & ALL Material shipped loose for the site completion of the manufactured product is ULTIMATELY the SOLE RESPONSIBILITY OF THE BUILDER LISTED BELOW to install and finish.

Builder to check appropriate box, sign, date, and return to N.E.H. Plans not checked, signed, and dated will be returned to Builder and subject to removal from Production Scheduling.

**PERMIT PLANS**

I HAVE REVIEWED THESE PLANS FOR ACCURACY AND HEREBY AUTHORIZE N.E.H. TO DO THE FOLLOWING;

THERE ARE NO CHANGES TO THIS PLAN, RELEASE THE JOB FOR PRODUCTION.

REVISE THE PLANS AS NOTED AND RELEASE THESE PLANS FOR PRODUCTION.

REVISE THESE PLANS AS NOTED AND SEND ME ANOTHER SET OF PERMIT PLANS TO REVIEW.

<b>11256</b>	Drawn: 3/10/17 JMS		277 Locust Street, Suite B Dover, NH 03820 www.newenglandhomes.net (telephone):800.800.8831 (fax):603.431.8540
	Revisions:		
Revisions:	3/24/17 RTA		145 COLONIAL
	4/3/17 RTA		
	4/4/17 RTA		
	5/8/17 RTA		
Sheet:	5/8/17 RTA	Builder:	CMH, INC
<b>S-101A</b>	5/31/17 RTA	Scale:	1:45
	7/25/17 RTA	Structure Desc:	COLONIAL
<b>FIRST FLOOR FRAMING - BOX A</b>			

Signature \_\_\_\_\_ Date \_\_\_\_\_  
 NEW ENGLAND HOMES INDEPENDENT BUILDERS DULY AUTHORIZED AGENT PER CONTRACT AGREEMENT