

GROUND FLOOR
SCALE : 1/4" = 1'-0"

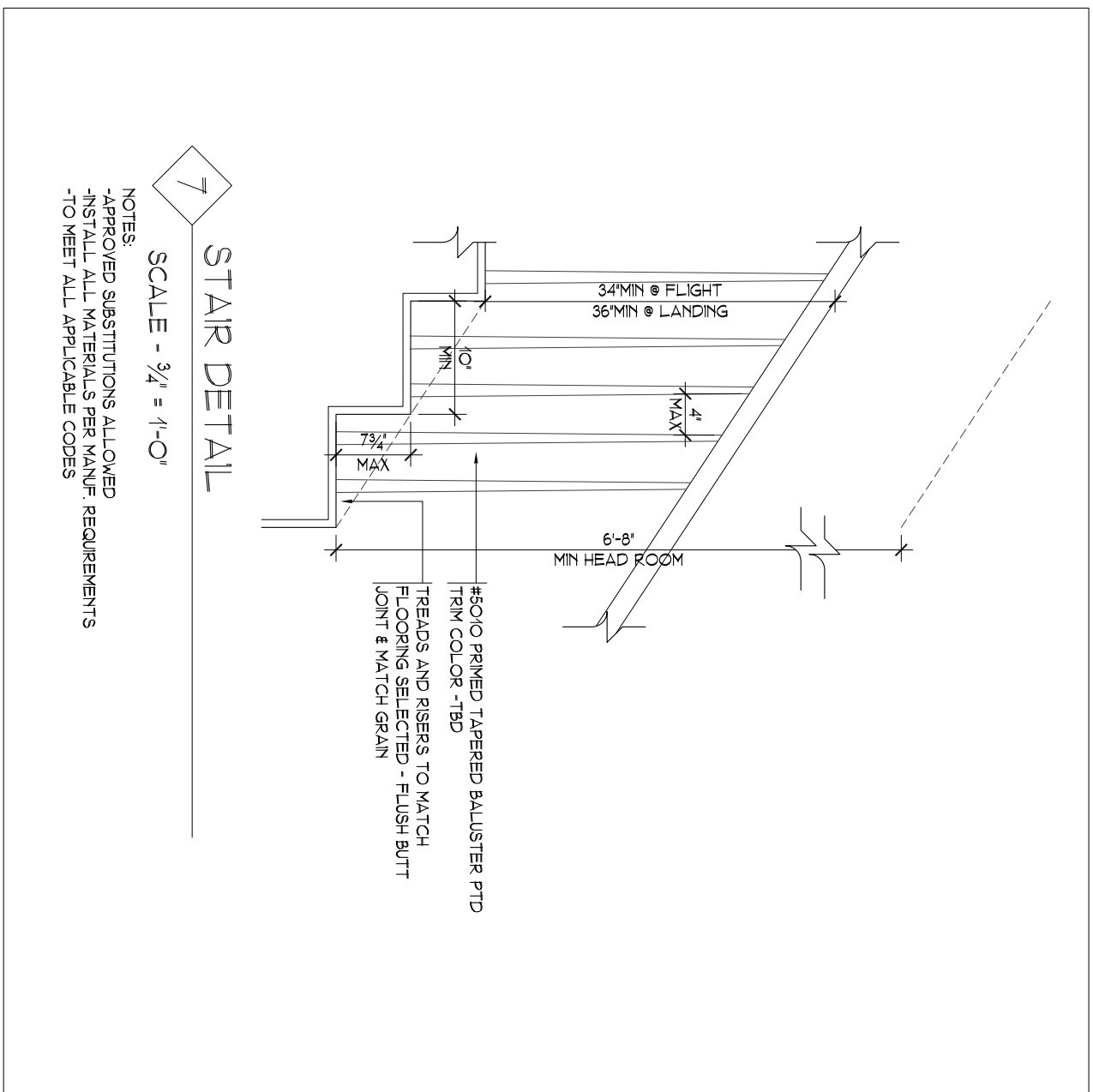
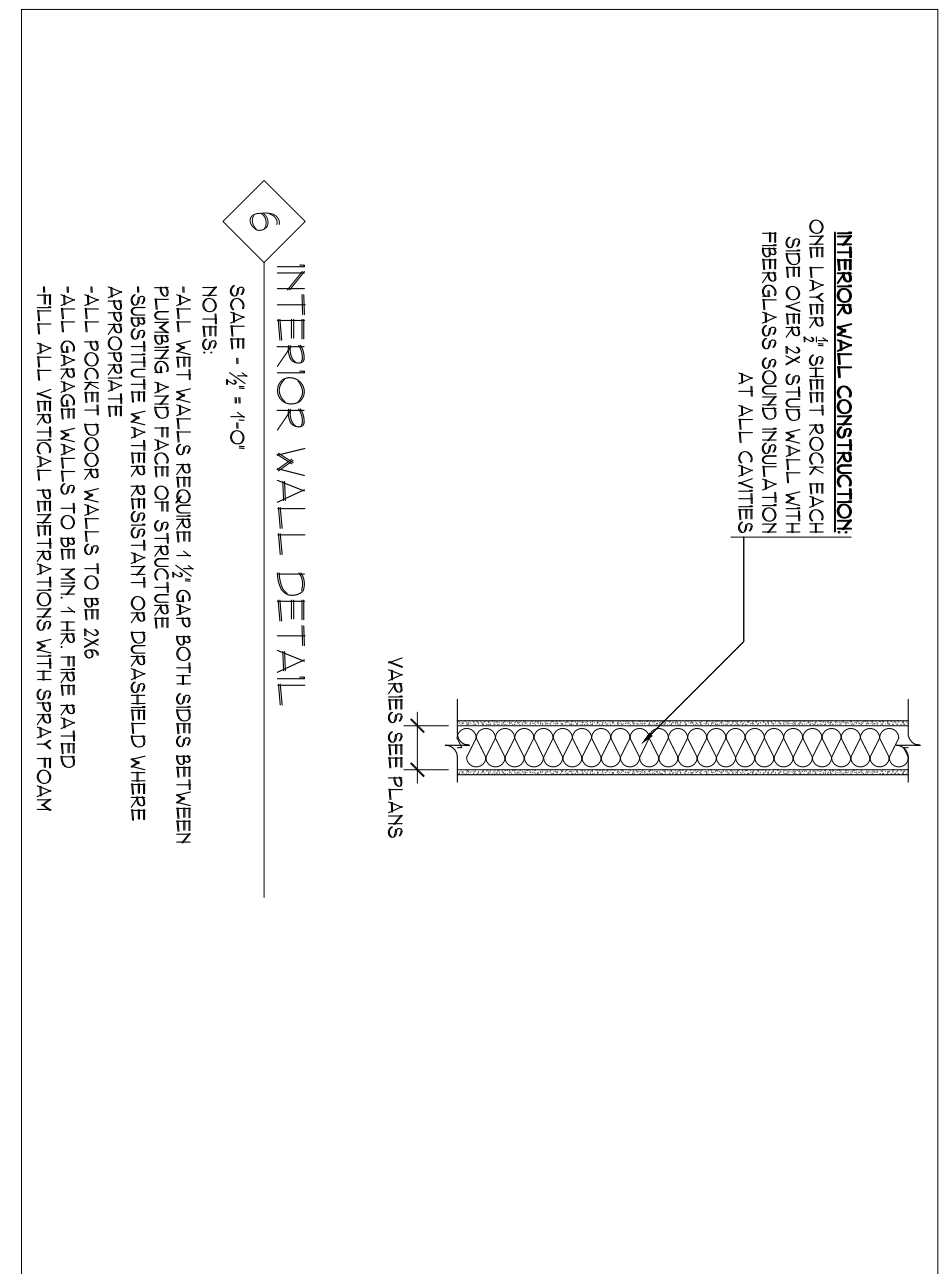
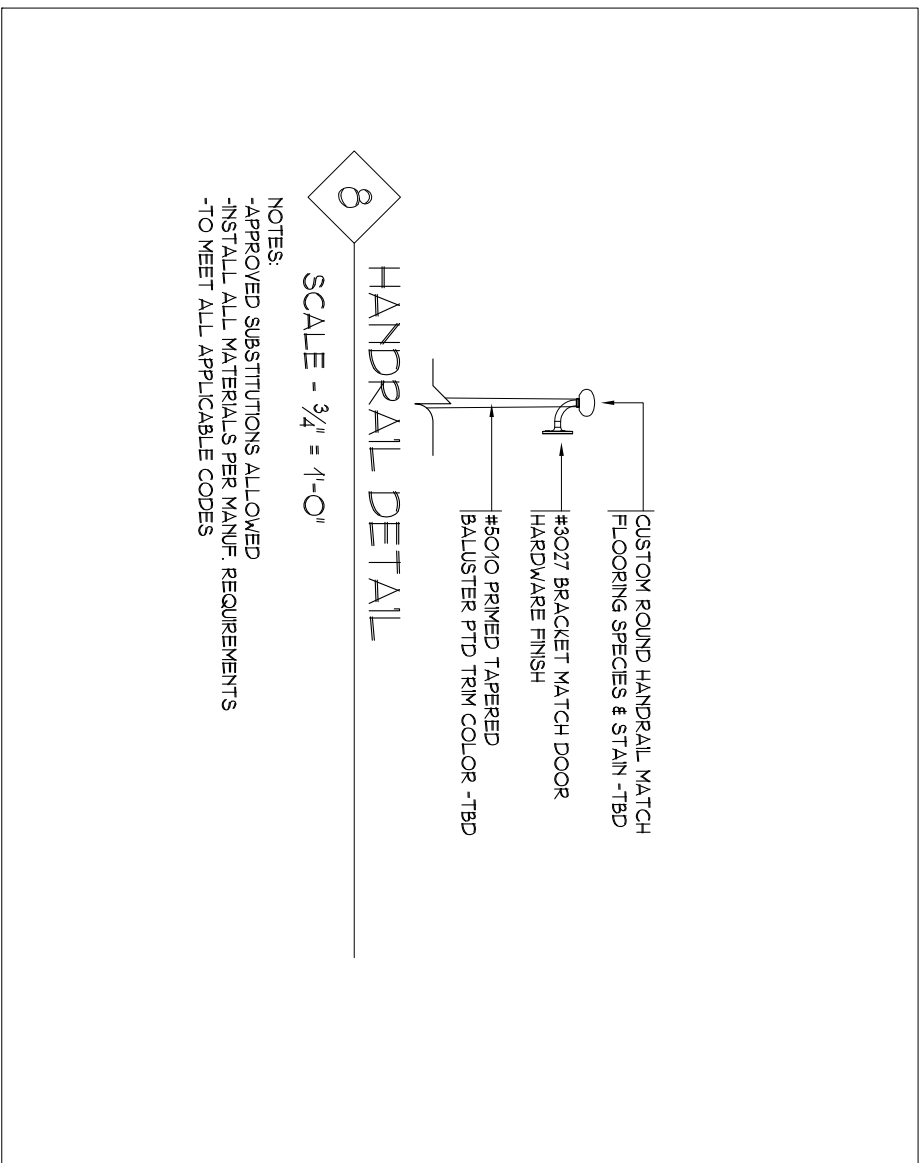
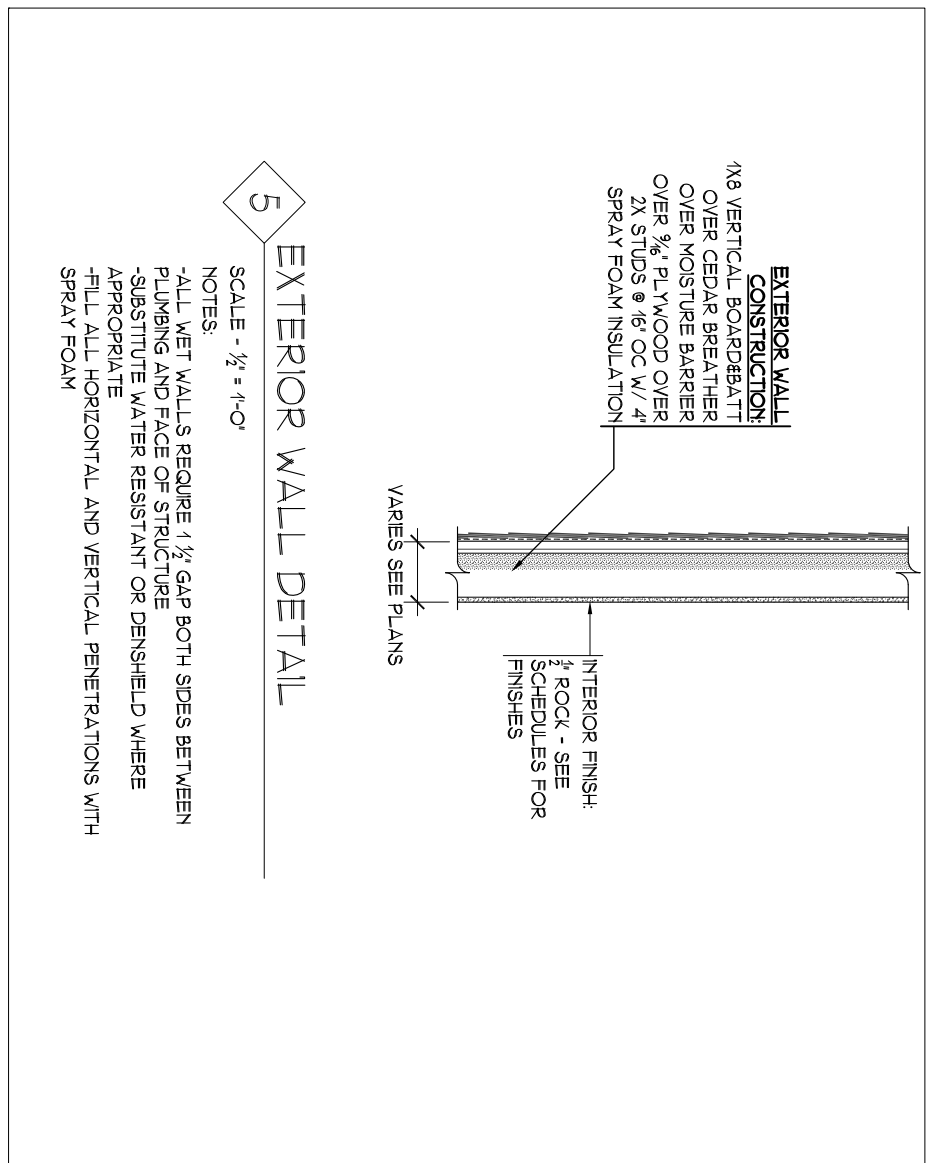

Sheet #	Title	Rev	Date	By	Check
A1.1		E017			
		089			