

15RLS2 Submittal



**AOU15RLS2, ASU15RLS2
Inverter Driven Heat Pump**

Job Name: St Christopher's Church
 Location: 15 Central Ave, Peaks Island
 Engineer: n/a
 Submitted to: City of Portland
 Submitted by: Guggen Energy
 Reference: n/a

Approval: _____
 Date: _____
 Construction: _____
 Unit #: _____
 Drawing #: _____

Outdoor Unit Power	208-230VAC-1Ph-60Hz	
Available Voltage Range	187-253VAC	
Fuse Size, Max.	20A	
NCA	13.5A	
Compressor	Inverter Driven Variable Speed DC Rotary	
No. used	1	
Output	1000W	
Lubricant Oil	POE (RB68)	
Fan type	Propeller	
Motor Output	115W	
Airflow Rate	Cooling/Heating (High)	1206 / 1082CFM
Refrigerant	R410A	
Outdoor Unit	2lbs 12.0oz	
Control	Electronic Expansion Valve	
O.D. Discharge	(in)	1/4"(Flare)
O.D. Suction	(in)	1/2"(Flare)
Dimensions	H x W x D	
Uncrated	(in)	24-1/2 x 31-3/32 x 11-11/32
	(mm)	(620 x 790 x 290)
Crated	(in)	28-1/16 x 37-7/32 x 15-9/16
	(mm)	(713 x 945 x 395)
Weight	Outdoor	
Net	86lbs (39kg)	
Gross Shipping	95lbs (43kg)	
Cooling		
Rated Capacity	14,500BTU/h	
Min-Max Capacity	3,100~18,400BTU/h	
Rated Power Input	4.25kw	
Max. Power Input	5.40kw	
SEER	21.5	
Outdoor Sound Rating	51dB	
Heating		
Rated Capacity	18,000BTU/h	
Min-Max Capacity	3,100~23,900BTU/h	
Rated Power Input	5.28kw	
Max. Power Input	7.00kw	
HSPF	12	
Outdoor Sound Rating	51dB	
Piping Lengths		
Max. Piping Length (Total)	66ft	
Max. Pipe Height Difference	49ft	
Connection method	(Flared)	
Operating Range		
Cooling	14°F~115°F DB	
Heating	-5°F~75°F DB	

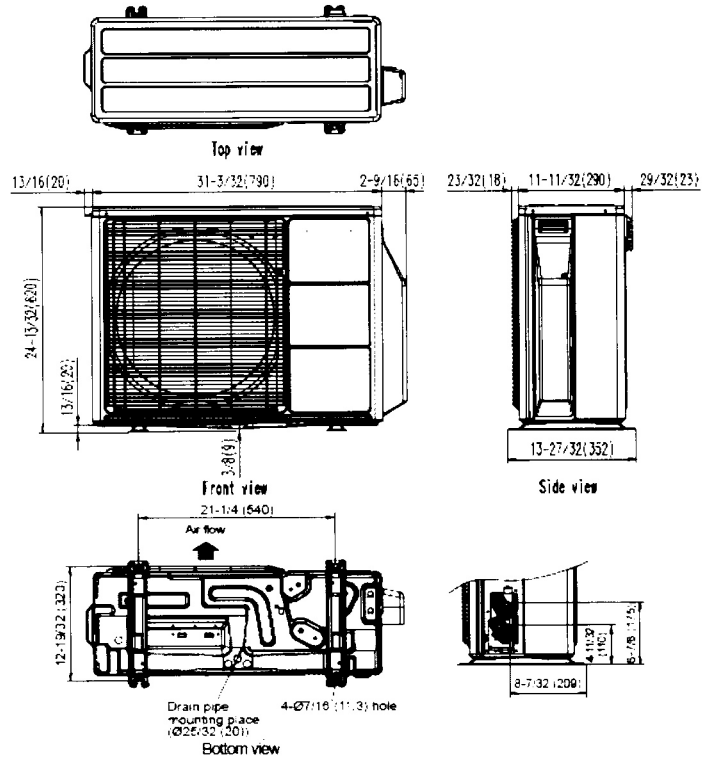
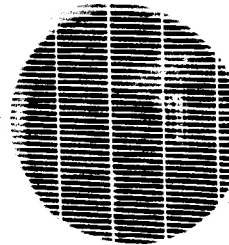

Fujitsu General America, Inc.
 Fairfield, NJ 07004
 Toll Free: 1-888-888-3424
 Fax: (973) 836-0447
 www.fujitsugeneral.com

Fujitsu products are subject to continuous improvements. Fujitsu reserves the right to modify product design, specifications and information in this data sheet without notice and without incurring any obligations.

Note: Specifications are based on the following conditions.

Power source of specifications: 230V

Cooling: Indoor temperature of 80°F(26.67°C)DB / 67°F(19.44°C)WB, and outdoor temperature of 95°F(35°C)DB/75°F(23.89°C)WB.

Heating: Indoor temperature of 70°F(21.11°C)DB / 60°F(15.56°C)WB, and outdoor temperature of 47°F(8.33°C)DB/43°F(6.11°C)WB.

Pipe length: 24ft. 7in.(7.5m), Height difference: 0 ft.(0m) [Outdoor unit - Indoor unit]





Indoor Unit Power	208-230VAC-1Ph-60Hz	
Available Voltage Range	187-253VAC	
Fan type	Cross flow	
Motor Output	29W	
MCA	0.4A	

Sound Pressure Level		
Cooling	Lo-Hi	25-45dB
Heating	Lo-Hi	25-45dB

Airflow rate		
Cooling	Lo-Hi	229-529dB
Heating	Lo-Hi	253-559dB

Dimensions	H x W x D	
Uncrated	(in)	11-3/32 x 34-1/4 x 7-9/32
	(mm)	(282 x 870 x 185)
Crated	(in)	9-23/32 x 36-7/32 x 14-11/16
	(mm)	(247 x 920 x 373)

Weight	Indoor	
Net	21lbs (9.5kg)	
Gross Shipping	27lbs (12kg)	

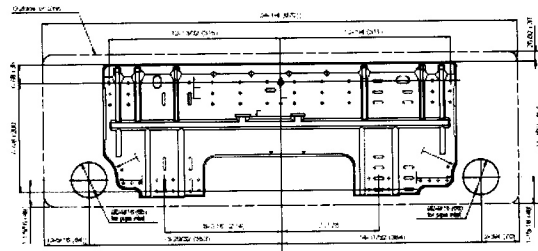
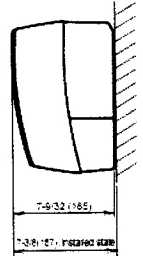
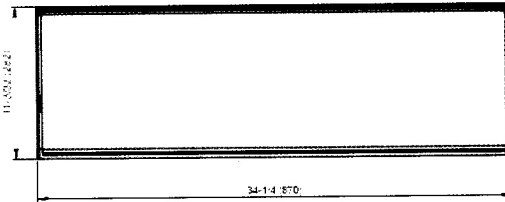

Fujitsu General America, Inc.
 Fairfield, NJ 07004
 Toll Free: 1-888-888-3424
 Fax: (973) 836-0447
www.fujitsugeneral.com

Fujitsu products are subject to continuous improvements. Fujitsu reserves the right to modify product design, specifications and information in this data sheet without notice and without incurring any obligations.

