

Form # P 04

DISPLAY THIS CARD ON PRINCIPAL FRONTAGE OF WORK
CITY OF PORTLAND

Please Read
Application And
Notes, if Any,
Attached

BUILDING INSPECTION

PERMIT

PERMIT ISSUED
Permit Number 10003

This is to certify that DESOUSA ROBERT A /Property Owner JUL 14 2010

has permission to Replace foundation & Windows add new framing 3 structural steel beams

AT 20 MECHANIC ST PENN DS CBL 087 V001001 City of Portland

provided that the person or persons, firm or corporation accepting this permit shall comply with all of the provisions of the Statutes of Maine and of the Ordinances of the City of Portland regulating the construction, maintenance and use of buildings and structures, and of the application on file in this department.

Apply to Public Works for street line and grade if nature of work requires such information.

Notification of inspection must be given and written permission procured before this building or part thereof is lathed or otherwise closed-in. 24 HOUR NOTICE IS REQUIRED.

A certificate of occupancy must be procured by owner before this building or part thereof is occupied.

OTHER REQUIRED APPROVALS
Fire Dept. _____
Health Dept. _____
Appeal Board _____
Other _____
Department Name

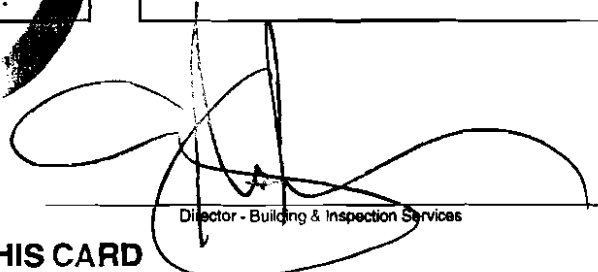
Director - Building & Inspection Services

PENALTY FOR REMOVING THIS CARD



CITY OF PORTLAND, MAINE

Department of Building Inspections

Original Receipt

7-2-2010

Received from

De Sousa -

Location of Work

30 Mechanic -

Cost of Construction \$ _____ Building Fee: _____

Permit Fee \$ _____ Site Fee: _____

Certificate of Occupancy Fee: _____

Total: 50

Building (I1) _____ Plumbing (I5) _____ Electrical (I2) _____ Site Plan (U2) _____

Other _____

CBL: 87-01

Check #: One _____ Total Collected \$ 50

**No work is to be started until permit issued.
Please keep original receipt for your records.**

Taken by: 

WHITE - Applicant's Copy
YELLOW - Office Copy
PINK - Permit Copy

City of Portland, Maine - Building or Use Permit Application

389 Congress Street, 04101 Tel: (207) 874-8703, Fax: (207) 874-8716

| | | |
|-----------------------|-------------|---------------------|
| Permit No: 10-0787 | Issue Date: | CBL: 087 V001001 |
|-----------------------|-------------|---------------------|

| | | | |
|---|------------------------------------|---|----------------------|
| Location of Construction: 20 MECHANIC ST <i>Peaks IS</i> | Owner Name: DESOUZA ROBERT A | Owner Address: 50 TYNG ST | Phone: |
| Business Name: | Contractor Name: Property Owner | Contractor Address: Portland | Phone: |
| Lessee/Buyer's Name | Phone: | Permit Type: Alterations - Dwellings | Zone: <i>IR 2</i> |

| | | | | |
|---------------------------------|---|------------------------|-----------------------------|--------------------|
| Past Use: Single Family Home | Proposed Use: Single Family Home - Replace foundation & Windows add new framing 3 structural steel beams | Permit Fee: \$50.00 | Cost of Work: \$3,000.00 | CEO District: 1 |
|---------------------------------|---|------------------------|-----------------------------|--------------------|

| | | |
|--------------------------|--|--|
| FIRE DEPT: <i>N/A</i> | <input checked="" type="checkbox"/> Approved <input checked="" type="checkbox"/> Denied | INSPECTION: Use Group: <i>R-3</i> Type: <i>SLB</i> <i>IRC 2003</i> |
|--------------------------|--|--|

Proposed Project Description:
Replace foundation & Windows add new framing 3 structural steel beams

Signature: _____
Signature: _____
PEDESTRIAN ACTIVITIES DISTRICT (P.A.D.)
Action: Approved Approved w/Conditions Denied
Signature: _____ Date: _____

| | | |
|-----------------------------|---------------------------------|------------------------|
| Permit Taken By: Idobson | Date Applied For: 07/02/2010 | Zoning Approval |
|-----------------------------|---------------------------------|------------------------|

| | | | |
|---|---|---|---|
| <p>1. This permit application does not preclude the Applicant(s) from meeting applicable State and Federal Rules.</p> <p>2. Building permits do not include plumbing, septic or electrical work.</p> <p>3. Building permits are void if work is not started within six (6) months of the date of issuance. False information may invalidate a building permit and stop all work..</p> | <p>Special Zone or Reviews</p> <p><input type="checkbox"/> Shoreland</p> <p><input type="checkbox"/> Wetland</p> <p><input type="checkbox"/> Flood Zone</p> <p><input type="checkbox"/> Subdivision</p> <p><input type="checkbox"/> Site Plan</p> <p>Maj <input type="checkbox"/> Minor <input type="checkbox"/> MM <input type="checkbox"/></p> <p>Date: <i>7/6/10</i></p> | <p>Zoning Appeal</p> <p><input type="checkbox"/> Variance</p> <p><input type="checkbox"/> Miscellaneous</p> <p><input type="checkbox"/> Conditional Use</p> <p><input type="checkbox"/> Interpretation</p> <p><input type="checkbox"/> Approved</p> <p><input type="checkbox"/> Denied</p> <p>Date: _____</p> | <p>Historic Preservation</p> <p><input checked="" type="checkbox"/> Not in District or Landmark</p> <p><input type="checkbox"/> Does Not Require Review</p> <p><input type="checkbox"/> Requires Review</p> <p><input type="checkbox"/> Approved</p> <p><input type="checkbox"/> Approved w/Conditions</p> <p><input type="checkbox"/> Denied</p> <p>Date: <i>9</i></p> |
|---|---|---|---|

PERMIT ISSUED

JUL 14 2010

City of Portland

CERTIFICATION

I hereby certify that I am the owner of record of the named property, or that the proposed work is authorized by the owner of record and that I have been authorized by the owner to make this application as his authorized agent and I agree to conform to all applicable laws of this jurisdiction. In addition, if a permit for work described in the application is issued, I certify that the code official's authorized representative shall have the authority to enter all areas covered by such permit at any reasonable hour to enforce the provision of the code(s) applicable to such permit.

| | | | |
|---|---------|------|-------|
| SIGNATURE OF APPLICANT | ADDRESS | DATE | PHONE |
| RESPONSIBLE PERSON IN CHARGE OF WORK, TITLE | | DATE | PHONE |

City of Portland, Maine - Building or Use Permit

389 Congress Street, 04101 Tel: (207) 874-8703, Fax: (207) 874-8716

| | | |
|-----------------------|---------------------------------|---------------------|
| Permit No: 10-0787 | Date Applied For: 07/02/2010 | CBI: 087 V001001 |
|-----------------------|---------------------------------|---------------------|

| | | | |
|--|------------------------------------|---|--------|
| Location of Construction: 20 MECHANIC ST PEAKS IS | Owner Name: DESOUSA ROBERT A | Owner Address: 50 TYNG ST | Phone: |
| Business Name: | Contractor Name: Property Owner | Contractor Address: Portland | Phone |
| Lessee/Buyer's Name | Phone: | Permit Type: Alterations - Dwellings | |

| | |
|---|--|
| Proposed Use: Single Family Home - Replace foundation & Windows add new framing 3 structural steel beams | Proposed Project Description: Replace foundation & Windows add new framing 3 structural steel beams |
|---|--|

| | | | |
|---|---|----------------------------------|----------------------------------|
| Dept: Zoning | Status: Approved with Conditions | Reviewer: Marge Schmuckal | Approval Date: 07/06/2010 |
| Note: | Ok to Issue: ✓ | | |
| <ol style="list-style-type: none"> 1) Separate permits shall be required for future decks, sheds, pools, and/or garages. 2) This is NOT an approval for an additional dwelling unit. You SHALL NOT add any additional kitchen equipment including, but not limited to items such as stoves, microwaves, refrigerators, or kitchen sinks, etc. Without special approvals. 3) This property shall remain a single family dwelling. Any change of use shall require a separate permit application for review and approval. 4) This permit is being approved on the basis of plans submitted. Any deviations shall require a separate approval before starting that work. It is understood that there will be no enlargement of the existing footprint of the building and no enlargement in the existing envelope of the building. | | | |
| Dept: Building | Status: Approved with Conditions | Reviewer: Tammy Munson | Approval Date: 07/14/2010 |
| Note: | Ok to Issue: ✓ | | |
| <ol style="list-style-type: none"> 1) Separate permits are required for any electrical, plumbing, sprinkler, fire alarm HVAC systems, heating appliances, commercial hood exhaust systems and fuel tanks. Separate plans may need to be submitted for approval as a part of this process. 2) Application approval based upon information provided by applicant. Any deviation from approved plans requires separate review and approval prior to work. | | | |

PERMIT ISSUED

JUL 14 2010

City of Portland

BUILDING PERMIT INSPECTION PROCEDURES

Please call 874-8703 or 874-8693 (ONLY)

or email: buildinginspections@portlandmaine.gov

With the issuance of this permit, the owner, builder or their designee is required to provide adequate notice to the City of Portland Inspection Services for the following inspections. Appointments must be requested 48 to 72 hours in advance of the required inspection. The inspection date will need to be confirmed by this office.

- **Please read the conditions of approval that is attached to this permit!! Contact this office if you have any questions.**
- **Permits expire in 6 months, if the project is not started or ceases for 6 months.**
- **If the inspection requirements are not followed as stated below additional fees may be incurred due to the issuance of a "Stop Work Order" and subsequent release to continue with construction.**

 X **Framing/Rough Plumbing/Electrical: Prior to Any Insulating or drywalling**

 X **Final inspection required at completion of work.**

The project cannot move to the next phase prior to the required inspection and approval to continue, REGARDLESS OF THE NOTICE OR CIRCUMSTANCES.

IF THE PERMIT REQUIRES A CERTIFICATE OF OCCUPANCY, IT MUST BE PAID FOR AND ISSUED TO THE OWNER OR DESIGNEE BEFORE THE SPACE MAY BE OCCUPIED.

PERMIT ISSUED

JUL 14 2010

City of Portland



General Building Permit Application

If you or the property owner owes real estate or personal property taxes or user charges on any property within the City, payment arrangements must be made before permits of any kind are accepted.

| | | |
|---|---|--|
| Location/Address of Construction: <u>20 Mechanics St Peaks Island Me</u> | | |
| Total Square Footage of Proposed Structure/Area <u>900</u> | Square Footage of Lot | Number of Stories <u>2</u> |
| Tax Assessor's Chart, Block & Lot Chart# <u>87</u> Block# <u>V</u> Lot# <u>1</u> | Applicant *must be owner, Lessee or Buyer Name <u>Robert deSousa</u> Address <u>20 Mechanics St</u> City, State & Zip <u>Peaks Is Me 04108</u> | Telephone: <u>207-766-2920</u> |
| Lessee/DBA (If Applicable) RECEIVED JUL - 2 2010 | Owner (if different from Applicant) Name Address City, State & Zip | Cost Of Work: \$ <u>3000.00</u> C of O Fee: \$ _____ Total Fee: \$ <u>50</u> |
| Current legal use (i.e. <u>City of Portland</u>) and <u>Me 04108</u> Number of Residential Units <u>1</u> | | |
| If vacant, what was the previous use? _____ | | |
| Proposed Specific use: _____ | | |
| Is property part of a subdivision? <u>NO</u> If yes, please name _____ | | |
| Project description: <u>Replace foundation & windows - Permitted</u> <u>Add - New framing 3 structural steel beams</u> | | |
| Contractor's name: _____ | | |
| Address: <u>Above owner</u> | | |
| City, State & Zip _____ | | Telephone: _____ |
| Who should we contact when the permit is ready: _____ | | Telephone: _____ |
| Mailing address: _____ | | |

Please submit all of the information outlined on the applicable Checklists. Failure to do so will result in the automatic denial of your permit.

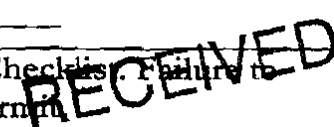

In order to be sure the City fully understands the full scope of the project, the Planning and Development Department may request additional information prior to the issuance of a permit. For further information or to download copies of this form and other applications visit the Inspections Division on-line at www.portlandmaine.gov or the Building Inspections Division office, room 315 City Hall or call 874-8703.

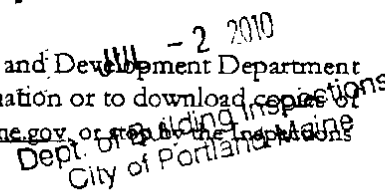

I hereby certify that I am the Owner of record of the named property, or that the owner of record authorizes the proposed work and that I have been authorized by the owner to make this application as his/her authorized agent. I agree to conform to all applicable laws of this jurisdiction. In addition, if a permit for work described in this application is issued, I certify that the Code Official's authorized representative shall have the authority to enter all areas covered by this permit at any reasonable hour to enforce the provisions of the codes applicable to this permit.

Signature: [Signature] Date: July 2 10

This is not a permit; you may not commence ANY work until the permit is issued

Window Schedule for mechanics of

5 - 30x30 Awning - w/ 3-2x6 headers
30" opening - OK
1/2" plywood sandwich

2 - 35x53 double hung - Headers
3-2x10 w/ 1/2" Ply
3' opening sandwich
OK

1 - 58x53 double hung - headers
3-2x10 1/2 Ply -
OK sandwich

2 - 30" wide doors - 3-2x8 1/2" ply
sandwich
OK

Insulation of Interior is R-16.

Amendment to Permit # 100295
 Robert de Sousa 20 mechanics st
 Peaks Island

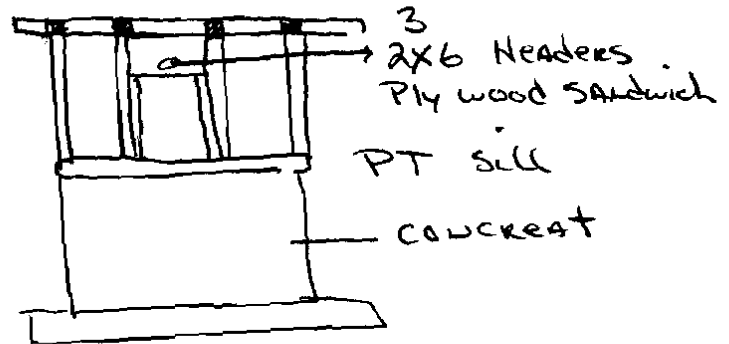
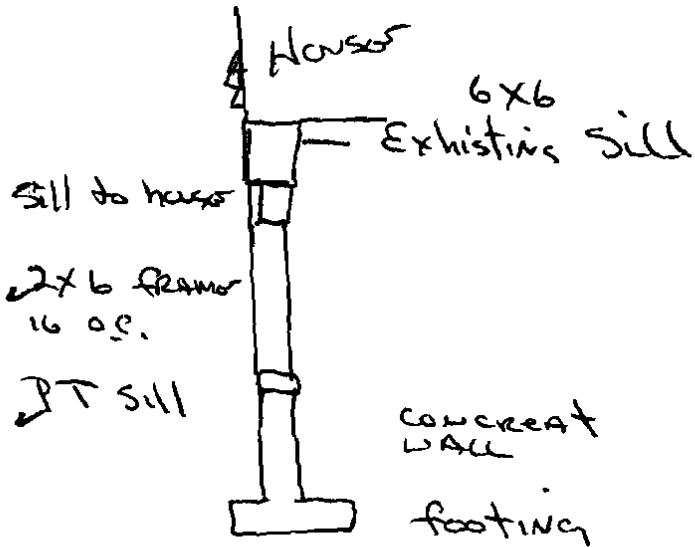

Install 3 - $8\frac{1}{8}'' \times 12\frac{1}{2}'' \times 35'$ I Beams
 Rated - 50 LBS per foot - Beams Posted on
 Lolly columns at 15' END of steel supported by
 ✓ 5 - 2x6x8

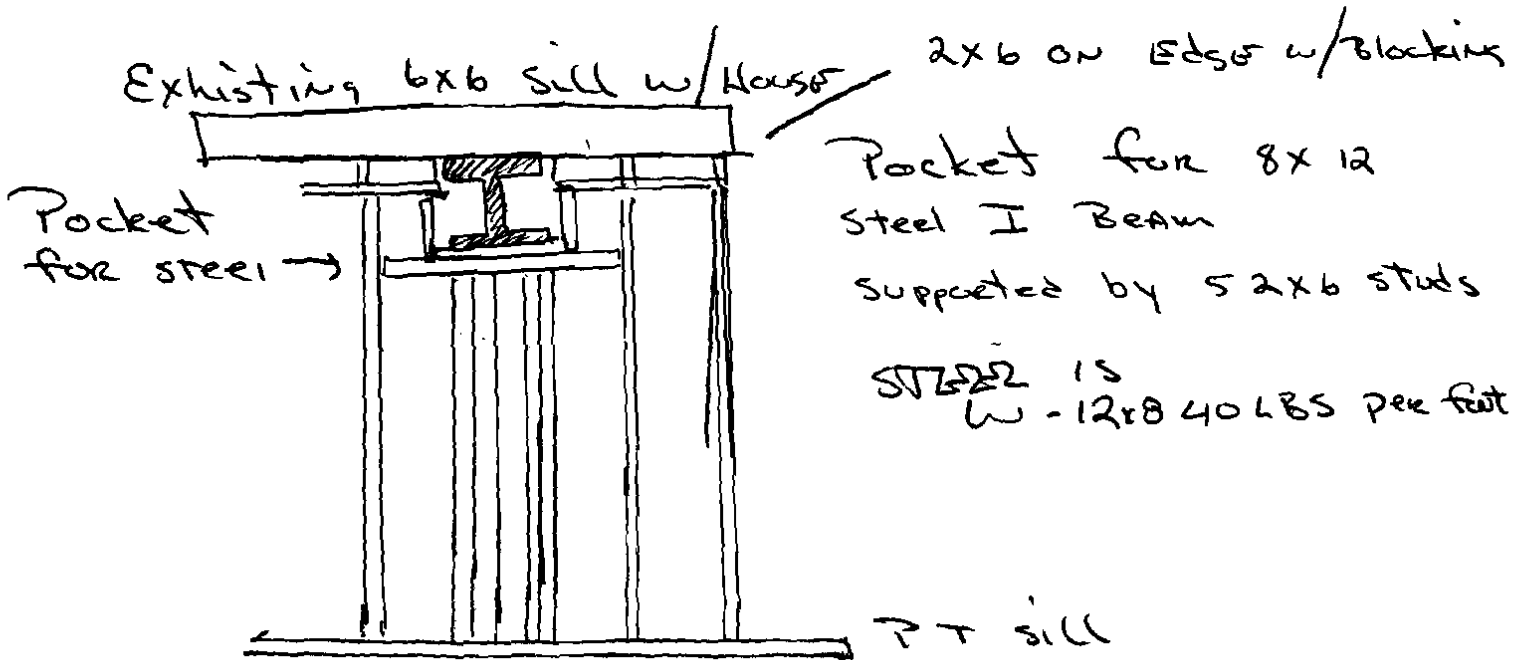

3 40 ft steel I Beams to add
 As carrying Beams - support Existing floor Joist
 Lolly columns as needed

