

DWG. #: VER30_GC6NLT1(4.3)CQE-MI-5

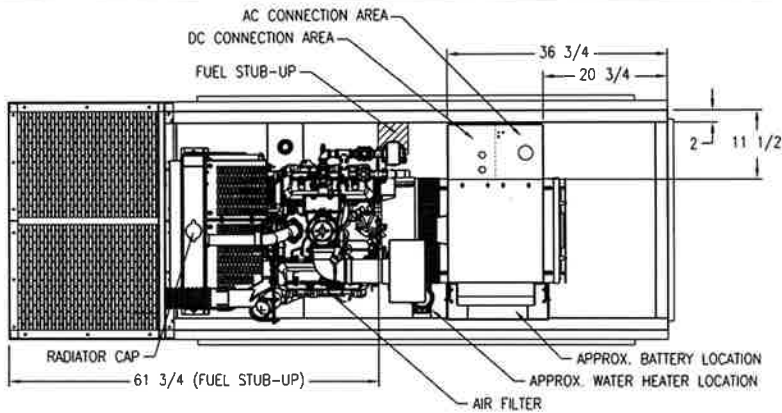

NOTES:

- 1) APPROX. WEIGHT: (WET) 1900#
- 2) REFERENCE BASE DRAWING: 105-5425
- 3) REFERENCE ENCLOSURE DRAWING: CQE-729-ALUM
- 4) SOUND LEVEL: 65 DBA @ 23 FT. (TO BE DETERMINED)
- 5) GEN-SET IS OFF-SET 1 3/4" TO LEFT SIDE OF BASE/ENCL.
- 6) ENCLOSURE & EXHAUST SYSTEMS ARE NOT SHOWN ON TOP VIEW
- 7) FUEL CONNECTIONS 3/4" NPT
- 8) PAINT FINISH: ANSI 61 GRAY

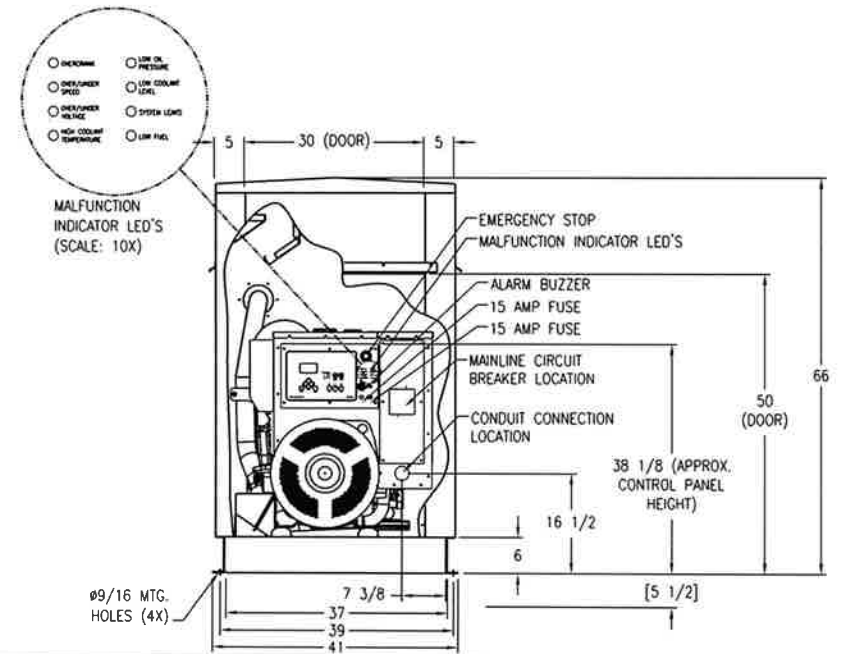
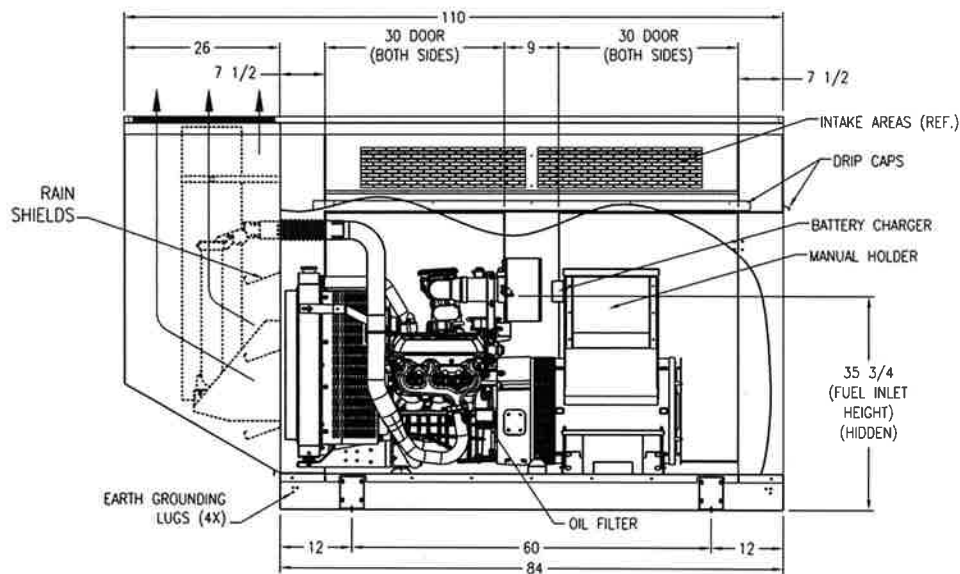

REVISION	DATE	REVISION DESCRIPTION	INITIALS
A	04-11-13	INITIAL RELEASE TO SALES AND ENGINEERING	JDA



THIS DRAWING IS A PROPERTY OF ON SITE ENERGY. IT IS TO BE USED ONLY FOR THE PROJECT AND SITE SPECIFICALLY IDENTIFIED THEREIN. ANY REUSE OR MODIFICATION OF THIS DRAWING WITHOUT THE WRITTEN PERMISSION OF ON SITE ENERGY IS STRICTLY PROHIBITED.

GEN-SET INFORMATION

ENGINE: GM 4.3L
 GENERATOR: 361
 RADIATOR: W/ ENG.
 RADIATOR AMBIENT: 50C
 DUCT FLANGE: 105-1401
 CONTROL PANEL: DGC-2020
 BASE: 105-5425

ENCLOSURE: CQE-729-ALUM
 BREAKER: AS SPECIFIED
 TANK: NA
 MUFFLER: 3 CRITICAL
 TRIMMER: NA
 ISOLATORS: PADS

DIMENSIONAL LAYOUT

DRAWN TO SCALE
 ALL DIMENSIONS ARE IN INCHES

MODEL: VER30_GC6NLT1
 DATE: 04-11-13
 DRAWN BY: JDA

DWG. #: VER30_GC6NLT1(4.3)CQE-MI-5