



Submittal Data: 9RLS3H

9,000 BTU Wall Mount

Inverter Driven Heat Pump

Job Name: Mac Medlen

Date: 2/23/16

Location: 34 Sterling Street, Peaks Island

Approval:

Engineer: n/a

Construction:

Submitted to: City of Portland

Unit #:

Submitted by: Joggin Energy

Drawing #:

Reference: n/a

General Features

- Wired or wireless remote
•Energy saving program
•Sleep timer
•24-hour timer
•Weekly timer
•Dry mode
•Powerful mode
•High performance heating
•Base pan heater
•Standard Warranty: 5 years parts, 7 years compressor. Applies to systems purchased before June 1st 2015*
•Extended Warranty: 10 years parts, 10 years compressor. Systems that have been installed on or after June 1st 2015 by licensed contractors and the online Product Registration has been submitted.**
•Elite Contractor Extended Warranty: 12 years parts, 12 years compressor. Systems that have been installed on or after June 1st 2015 by contractors who have met requirements and have been approved for elite contractor status plus, the online Product Registration has been submitted. ***

Model Information

Condenser..... AOU9RLS3H
Evaporator..... ASU9RLS3

Electrical

Available Voltage Range..... 208/230V AC 1ph-60Hz
Minimum Circuit Ampacity..... 14.4 A
Max Fuse Size..... 15A
Max Starting Current..... 3.3 A

Input Power

Cooling..... 0.5 kW
Heating..... 0.66 kW

Running Current

Cooling..... 2.5 A
Heating..... 3.3 A

Capacity

Nominal Cooling..... 9,000 Btu/h
Min-Max Cooling..... 3,100-12,000 Btu/h
Nominal Heating..... 12,000 Btu/h
Min-Max Heating..... 3,100-22,000 Btu/h

Compressor

Motor Output..... Rotary (inv x1) 850 W
Refrigerant..... R410a
Charge..... 2 lbs. 14 oz.
Oil..... FREOL a68SZ

Fan Motor

(Condenser) Type: DC..... Propeller x1
(Condenser) Motor Output..... 49 W
(Evaporator) Type: DC..... Cross flow fan x1
(Evaporator) Motor Output..... 61 W

Heat Exchanger {Condenser (C) Evaporator (E)}

Dimensions (H x W x D)
Condenser..... 23-1/8 x 34-11/16 x 1-7/16 in. (588x881x36.4 mm)
Evaporator..... Main 15-1/8 x 28-3/8 x 1-3/16 in. (384x720x30) Sub 3-5/16 x 28-3/8 x 1/2 in. (84x720x13.3 mm) 4-15/16 x 28-3/8 x 1/2 in. (126x720x13.3 mm)
Fin Pitch..... 20 FPI (C) Main 21 FPI Sub 18 FPI (E)
Rows x Stages..... 2 x 28 (C) Main 3 x 24 Sub 1 x 10 (E)
Pipe Type (Material)..... Copper (C) Copper (E)
Fin Type (Material)..... Aluminum (C) Aluminum (E)

Note: Specifications are based on the following conditions.
Cooling: in room temperature of 80°F (26.7°C) DB/67°F (19.44°C) WB, and outdoor temperature of 95°F (35°C) DB/75°F (23.9°C) WB.
Heating: in room temperature of 70°F (21.1°C) DB/59°F (15°C) WB, and outdoor temperature of 47°F (8.33°C) DB/43°F (6.1°C) WB.
Pipe length: 24ft. 7in. (7.5m). Height difference: 0ft. (0m) (Outdoor unit - indoor unit) (*Standard warranty)**10 year warranty***12 year warranty



Operation Temperature Range

Cooling..... 14°F (-10°C) to 115°F (46°C)
Heating..... -15°F (-26°C) to 75°F (24°C)

Efficiency

SEER..... 33
EER (cooling)..... 5.28 kW/kW
COP (heating)..... 5.33kW/kW / 18.2 Btu/hW
HSPF (heating)..... 14.2 Btu/hW

Enclosure (Condenser)

Material..... Painted galvanized steel
Color..... Beige (10 YR 7.5/1.0 NN)

Sound Pressure Level

Condenser..... 42 dB(A)
Evaporator..... 42 dB(A)

Dimensions

H x W x D
Condenser (mm)..... 24-1/2 (620) x 31-1/8 (790) x 11-7/16 (290)
Evaporator in. (mm)..... 11- 5/8 (295) x 37 (940) x 10-5/8 (270)

Connection Pipe

Liquid..... 1/4" / 6.35 mm Flare
Gas..... 3/8" / 9.52 mm Flare
Method (Liquid/Gas)..... Brazing
Max Length (Pre-charge)..... 66 ft.(20 m) / (49 ft. {15 m})
Max Height Difference..... 49 ft. (15 m)

Weight

Condenser..... 86 lbs. (38 kg)
Evaporator..... 31 lbs. (14 kg)

Accessories

UTY-RVNUM^..... Wired remote controller (backlit, shows room temp.)
UTY-RNNUM^..... Wired remote controller
UTY-RSNUM^..... Wired remote controller (simple)
UTY-TWBXF1..... Interface kit
UTY-XWZXZ5..... Dry contact wire kit
^1 Requires interface kit # UTY-TWBXF1 in order to connect these devices to them.



Fujitsu General America, Inc.
353 Route 46 West
Fairfield, NJ 07004
Toll Free: 1-888-888-3424
Fax: (973) 836-0447
www.fujitsugeneral.com

Dimensions: 9RLS3H

[Unit: in. (mm)]

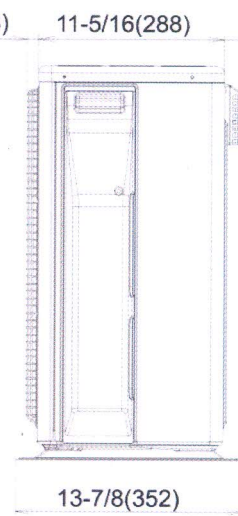
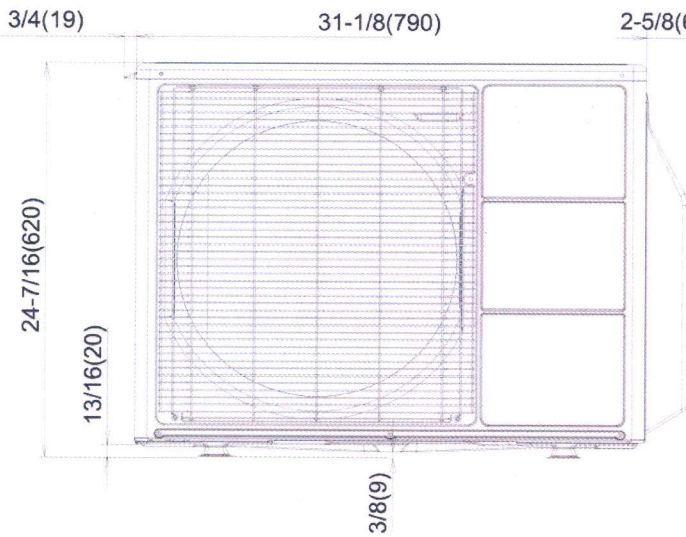
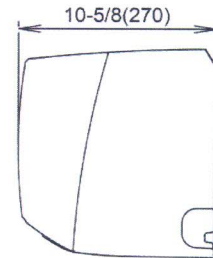
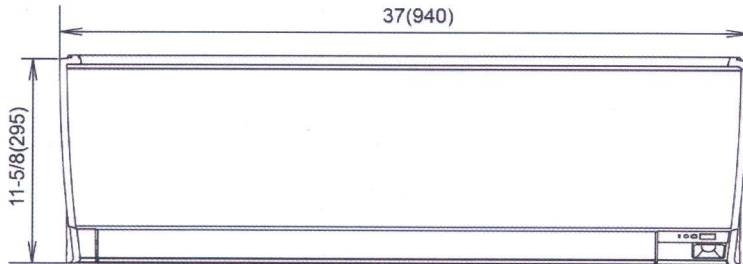

Front view

Side view

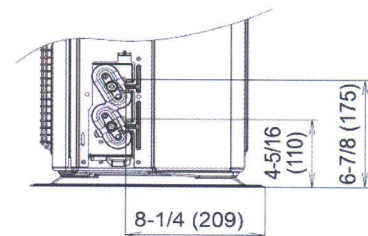
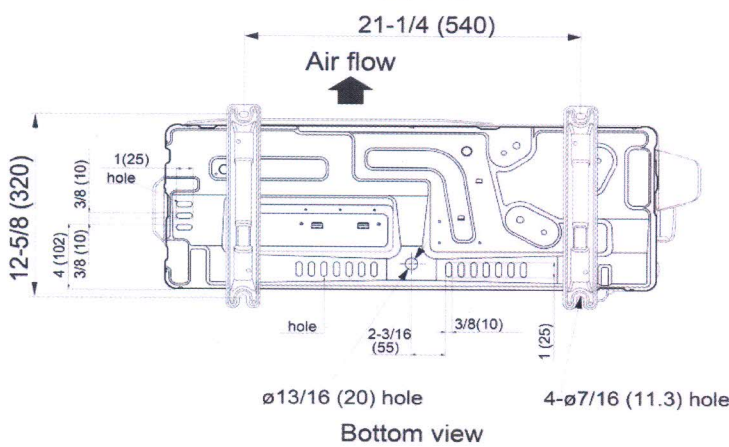

The Fujitsu logo is a registered trademark of Fujitsu Limited.
 The Halcyon logo and name is a trademark of Fujitsu General America, Inc.
 Copyright 2014 Fujitsu General America, Inc.
 Fujitsu's products are subject to continuous improvements. Fujitsu reserves the right to modify product design, specifications and information in this brochure without notice and without incurring any obligations.

FUJITSU
 Fujitsu General America, Inc.
 353 Route 46 West
 Fairfield, NJ 07004
 Toll Free: 1-888-888-3424
 Fax: (973) 836-0447
www.fujitsugeneral.com

**Submittal Data: 15RLS3H
Inverter Driven Heat Pump**

15,000 BTU Heat Pump System

Job Name: Mac Medlen
 Location: 34 Sterling Street, Peaks Island
 Engineer: n/a
 Submitted to: City of Portland
 Submitted by: Doggin Energy
 Reference: n/a

Date: 2/23/16
 Approval: _____
 Construction: _____
 Unit #: _____
 Drawing #: _____

General Features

- Refrigerant Type R410A.
- Human Sensor
- Wired and wireless remote controllers
- Double swing automatic
- Automatic airflow adjustment
- Low noise mode
- Powerful mode
- 5- Years Parts, 7-Years Compressor Warranty (See Warranty Statement for details)
- Program timer
- Weekly time

Model Information

Outdoor..... AOU15RLS3H
 Indoor..... ASU15RLS3

Electrical..... 208/230V AC 1ph-60Hz
 Available Voltage Range..... 208/230 +/- 10%
 Minimum Circuit Ampacity..... 18.2 A
 Max Fuse Size..... 20A
 Max Starting Current..... 5.2 A

Input Power

Cooling..... 1.04 kW
 Heating..... 1.15 kW

Running Current

Cooling..... 4.8 A
 Heating..... 5.2 A

Capacity

Nominal Cooling..... 15,000 Btu
 Min-Max Cooling..... 3,100-18,400 Btu/h
 Nominal Heating..... 18,000 Btu/h
 Min-Max Heating..... 3,100-23,900 Btu/h

Compressor

Motor Output..... Rotary (inv x1)
 Refrigerant..... 1,000 W
 Charge..... R410a
 Oil..... 3 lbs. 1 oz
 Oil..... FREOL a68SZ

Fan Motor

(Condenser) Type: DC..... Propeller x 1
 (Condenser) Motor Output..... 49 W
 (Evaporator) Type: DC..... Cross flow fan x 1
 (Evaporator) Motor Output..... 61 W

Heat Exchanger {Condenser (C) Evaporator (E)}

Dimensions (H x W x D)
 Condenser..... 23-1/8 x 34-11/16 x 1-7/16 in. (588x881x36.4 mm)
 Evaporator..... Main 15-1/8 x 28-3/8 x 1-3/16 in. (384x720x30) Sub 3-5/16 x 28-3/8 x 1/2 in. (84x720x13.3 mm) 4-15/16 x 28-3/8 x 1/2 in. (126x720x13.3 mm)
 Fin Pitch..... 20 FPI (C) Main 21 FPI Sub 18 FPI (E)
 Rows x Stages..... 2 x 28 (C) Main 3 x 24 Sub 1 x 10 (E)
 Pipe Type (Material)..... Copper (C) Copper (E)
 Fin Type (Material)..... Aluminum (C) Aluminum (E)

Note: Specifications are based on the following conditions.
 Cooling: In room temperature of 80°F (26.7°C) DB/67°F (19.44°C) WB, and outdoor temperature of 95°F (35°C) DB/75°F (23.9°C) WB.
 Heating: In room temperature of 70°F (21.1°C) DB/59°F (15°C) WB, and outdoor temperature of 47°F (8.33°C) DB/43°F (6.11°C) WB.
 Pipe length: 24ft. 7in. (7.5m). Height difference: 0ft. (0m) (Outdoor unit - indoor unit)

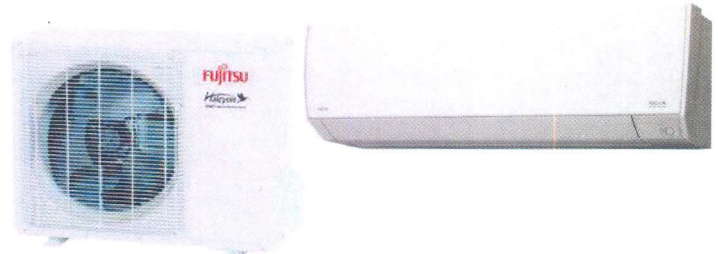

Operation Temperature Range

Cooling..... 14°F (-10°C) to 115°F (46°C)
 Heating..... -15°F (-26°C) to 75°F (24°C)

Efficiency

SEER..... 25.3
 EER (cooling)..... 4.09 kW/kW
 COP (heating)..... 4.59 kW/kW / 15.7 Btu/hW
 HSPF (heating)..... 13.4 Btu/hW

Enclosure (Condenser)

Material..... Painted galvanized steel
 Color..... Beige (10 YR 7.5/1.0 NN)

Sound Pressure Level

Outdoor..... 49 dB(A)
 Indoor..... 45 dB(A)

Dimensions

H x W x D
 Outdoor in. (mm)..... 24-1/2 (620) x 31-1/8 (790) x 11-7/16 (290)
 Indoor in. (mm)..... 11-5/8 (295) x 37 (940) x 10-5/8 (270)

Connection Pipe

Liquid..... 1/4" / 6.35 mm Flare
 Gas..... 1/2" / 12.7 mm Flare
 Method (Liquid/Gas)..... Brazing
 Max Length (Pre-charge)..... 66 ft.(20 m) / (49 ft. {15 m})
 Max Height Difference..... 49 ft. (15 m)

Weight

Outdoor..... 88 lbs (40 kg)
 Indoor..... 31 lbs (14 kg)

Accessories

Wired Remote Controller..... UTY-RVNUM
 Wired Remote Controller..... UTY-RNNUM
 Simple Remote Controller..... UTY-RSNUM
 Communication Kit..... UTY-TWBXF1
 External Connection Kit..... UTY-XWZXZ5

Dimensions: 15RLS3H

[Unit: in. (mm)]

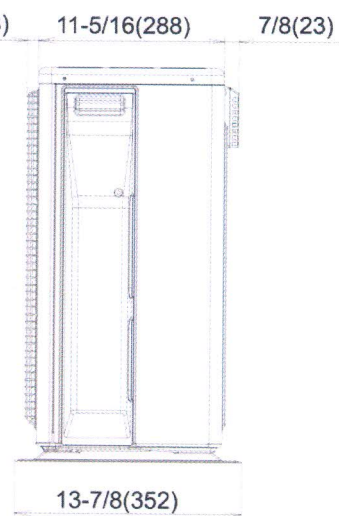
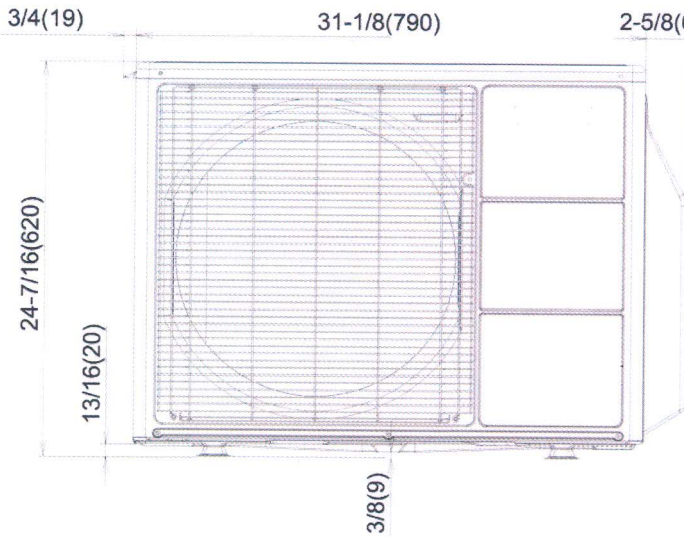
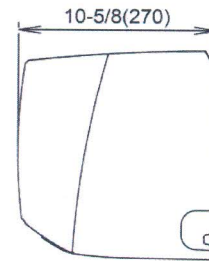
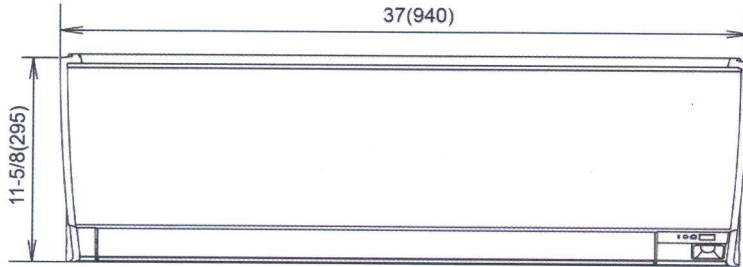

Front view

Side view

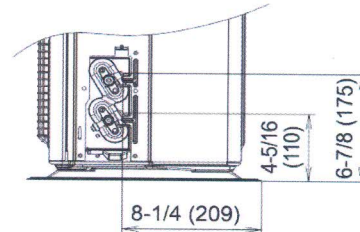
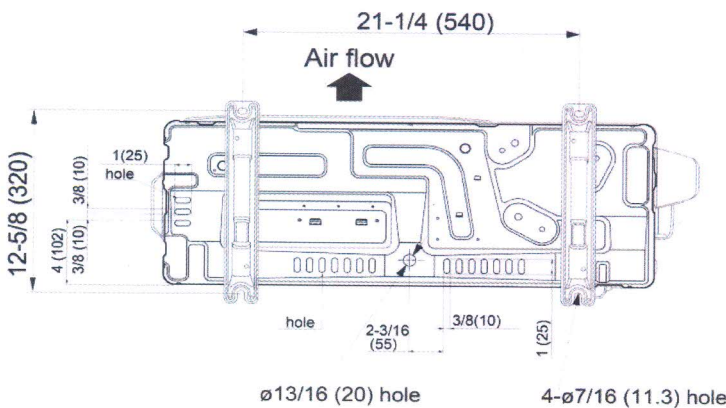

ø13/16 (20) hole

4-ø7/16 (11.3) hole

Bottom view