

professional seal

consultants

ISSUE DATE

PERMITS 7-21-2017

SCALE: 1" = 1'-0"

Detail Sections at Deck and Ceilings

A.7

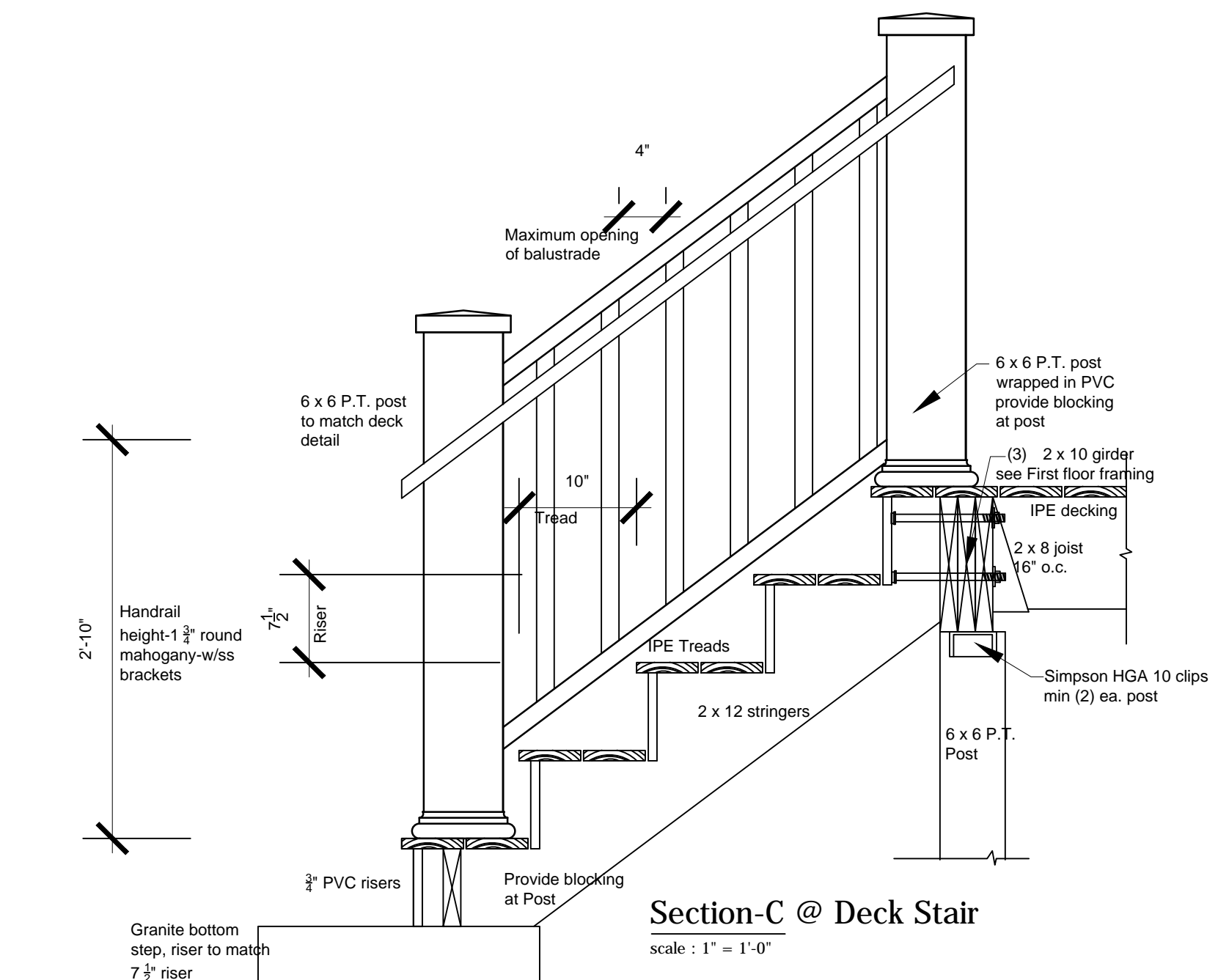

Section-C @ Deck Stair
 scale: 1" = 1'-0"

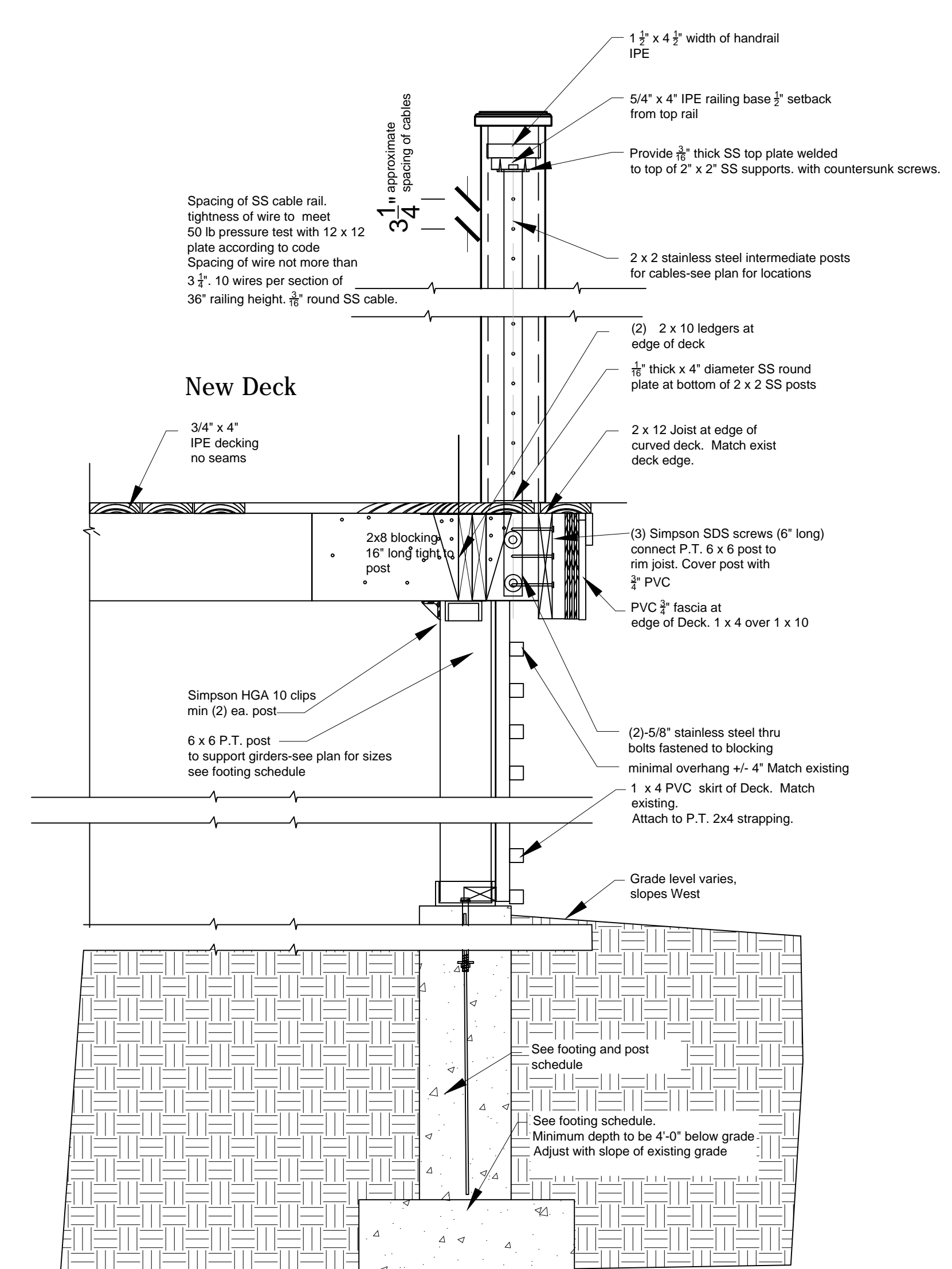

Section-B @ 2 x 2 SS post
 scale: 1" = 1'-0"

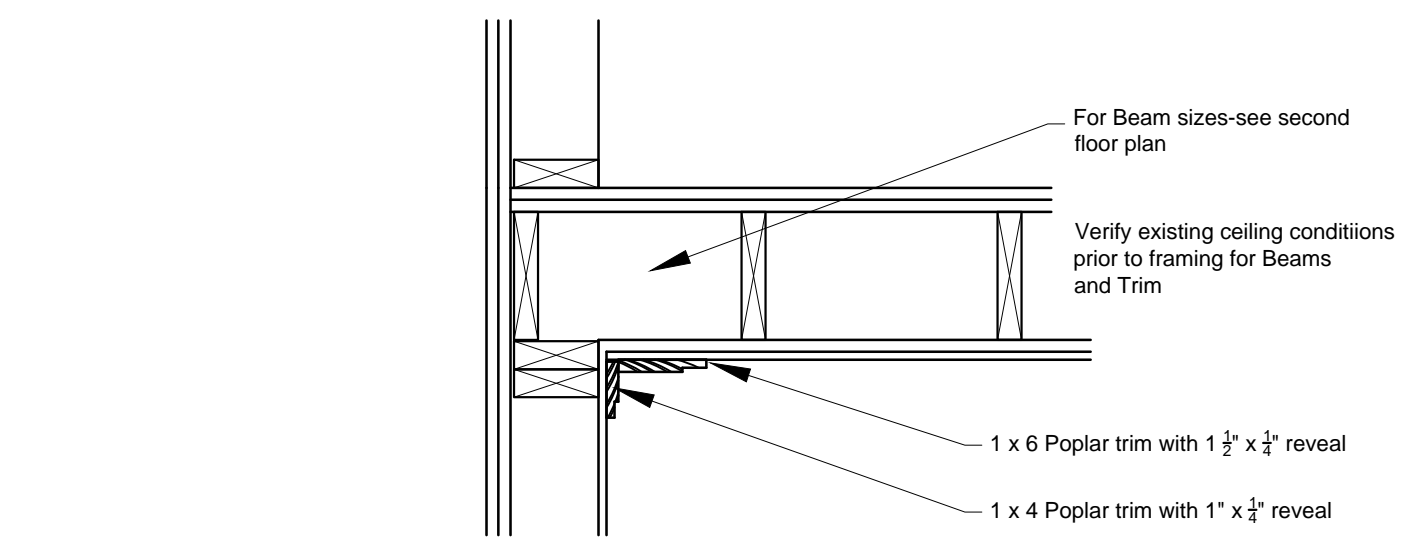

Section-F Typical Ceiling Wall Crown Section
 At Living Room, Kitchen and Hall
 scale: 1" = 1'-0"

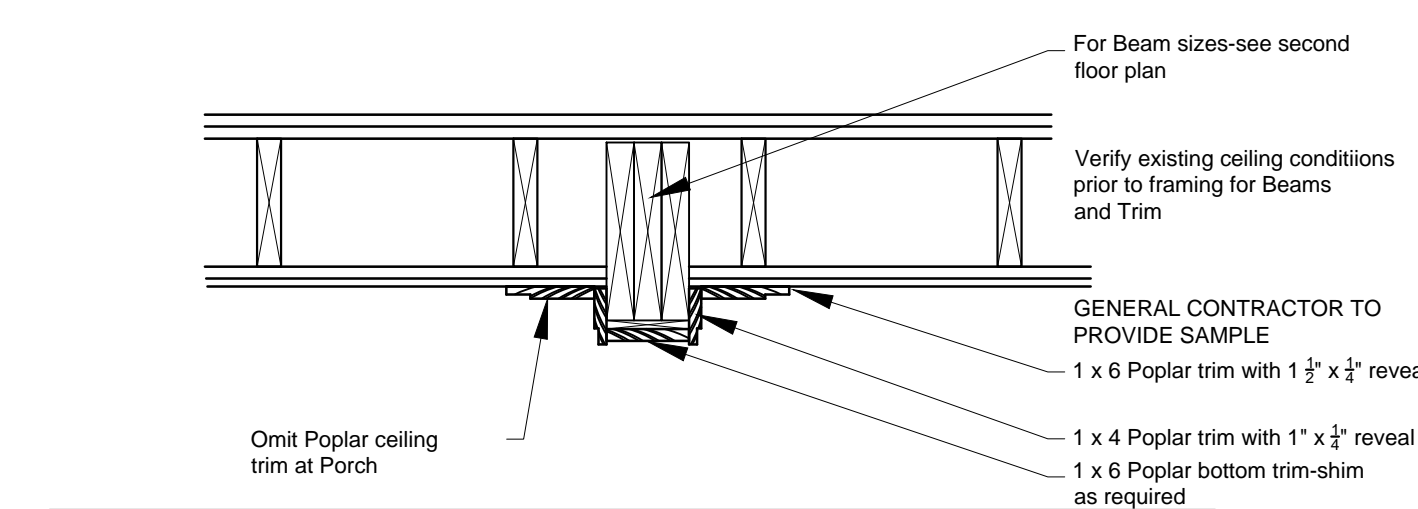

Section-E Typical Ceiling Beam Sections
 At Living Room and Hall
 scale: 1" = 1'-0"

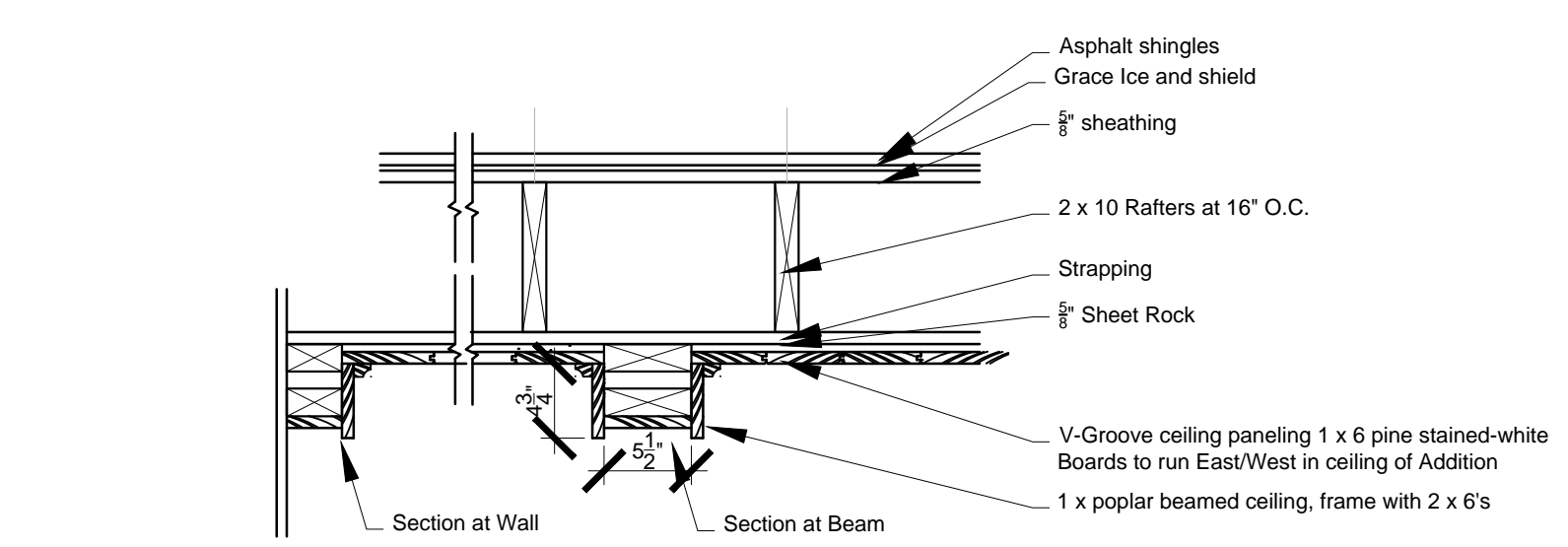

Section-D Ceiling Beam Details-Sections
 At new Addition Bedroom and Loft
 scale: 1" = 1'-0"

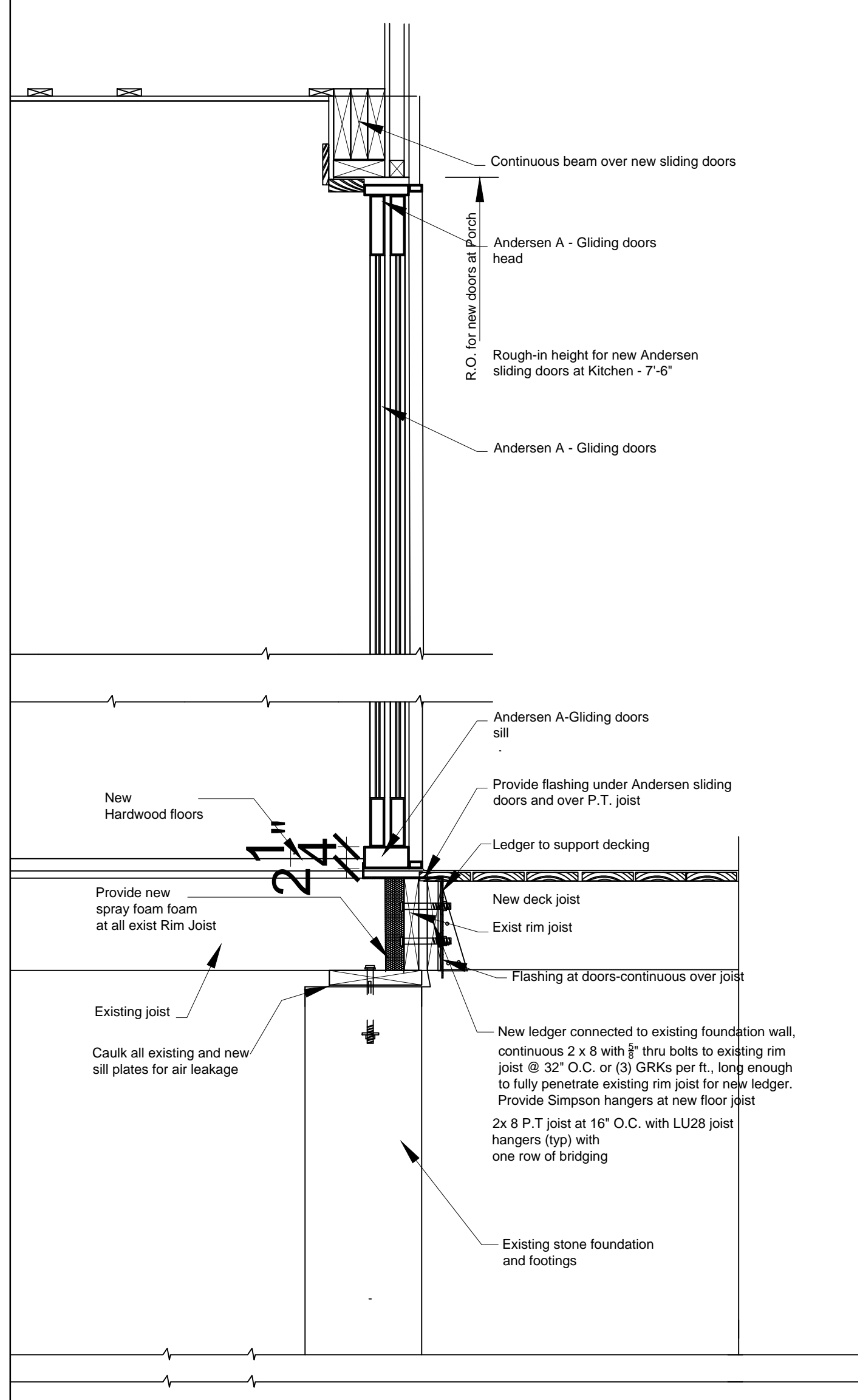

Section-A First Floor Deck-off Kitchen/Dining Area
 scale: 1" = 1'-0"