

**City of Portland, Maine - Building or Use Permit Application**

389 Congress Street, 04101 Tel: (207) 874-8703, Fax: (207) 874-8716

PERMIT ISSUED

Permit No: 03-0302	Issue Date: MAY 08 2003	CBL: 084 R032001
-----------------------	----------------------------	---------------------

Location of Construction: 20 Island Ave <i>P.I.</i>	Owner Name: W & W Inc	Owner Address: 498 Island Ave	Phone: 766-4400
Business Name:	Contractor Name: Applicant	Contractor Address: Portland	Phone:
Lessee/Buyer's Name:	Phone:	Permit Type: Additions - Commercial	Zone: <i>T-B</i>

Past Use: Restaurant/Lodging	Proposed Use: Restaurant/Lodging	Permit Fee: \$37.00	Cost of Work: \$1,900.00	CEO District: 3	<i>SHORELAND</i>
---------------------------------	-------------------------------------	------------------------	-----------------------------	--------------------	------------------

FIRE DEPT: <input checked="" type="checkbox"/> Approved <input type="checkbox"/> Denied  INSPECTION: Use Group: <i>R1 Acc</i> Type: <i>5B</i> <i>5/6/03</i>	Signature: <i>[Signature]</i>	Signature: <i>[Signature]</i>
--	-------------------------------	-------------------------------

Proposed Project Description:  
Addition of One 16'x16' Octogonal Gazebo and One 10'x10' Octogonal Gazebo *Accessory*

PEDESTRIAN ACTIVITIES DISTRICT (P.A.D.)		
Action: <input type="checkbox"/> Approved <input type="checkbox"/> Approved w/Conditions <input type="checkbox"/> Denied	Signature:	Date:

Permit Taken By: gad	Date Applied For: 04/04/2003	<b>Zoning Approval</b>	
-------------------------	---------------------------------	------------------------	--

1. This permit application does not preclude the Applicant(s) from meeting applicable State and Federal Rules.  2. Building permits do not include plumbing, septic or electrical work.  3. Building permits are void if work is not started within six (6) months of the date of issuance. False information may invalidate a building permit and stop all work..	Special Zone or Reviews <input type="checkbox"/> Shoreland <i>NA per 14-449</i> <input type="checkbox"/> Wetland <input type="checkbox"/> Flood Zone <i>panel 15 ZNEC</i> <input type="checkbox"/> Subdivision <input type="checkbox"/> Site Plan  Maj <input type="checkbox"/> Minor <input type="checkbox"/> MM <input type="checkbox"/> Date: <i>5/6/03</i>	Zoning Appeal <input type="checkbox"/> Variance <input type="checkbox"/> Miscellaneous <input type="checkbox"/> Conditional Use <input type="checkbox"/> Interpretation <input type="checkbox"/> Approved <input type="checkbox"/> Denied  Date:	Historic Preservation <input checked="" type="checkbox"/> Not in District or Landmark <input type="checkbox"/> Does Not Require Review <input type="checkbox"/> Requires Review <input type="checkbox"/> Approved <input type="checkbox"/> Approved w/Conditions <input type="checkbox"/> Denied  Date: <i>[Signature]</i>
--	--	--	--

**CERTIFICATION**

I hereby certify that I am the owner of record of the named property, or that the proposed work is authorized by the owner of record and that I have been authorized by the owner to make this application as his authorized agent and I agree to conform to all applicable laws of this jurisdiction. In addition, if a permit for work described in the application is issued, I certify that the code official's authorized representative shall have the authority to enter all areas covered by such permit at any reasonable hour to enforce the provision of the code(s) applicable to such permit.

SIGNATURE OF APPLICANT	ADDRESS	DATE	PHONE
------------------------	---------	------	-------

RESPONSIBLE PERSON IN CHARGE OF WORK, TITLE	DATE	PHONE
---	------	-------

03-0302

# All Purpose Building Permit Application

If you or the property owner owes real estate or personal property taxes or user charges on any property within the City, payment arrangements must be made before permits of any kind are accepted.

Location/Address of Construction: <u>20 Island Ave Peaks Island Me</u>		
Total Square Footage of Proposed Structure <del>000</del> <del>0000</del> <u>square feet</u> / <del>1000</del> <u>square feet</u> <small>(% of lot)</small>	Square Footage of Lot <u>20177.6</u>	
Tax Assessor's Chart, Block & Lot Chart# <u>084</u> Block# <u>R</u> Lot# <u>032</u>	Owner: <u>W+W Inc</u>	Telephone: <u>(207) 766-4400</u>
Lessee/Buyer's Name (If Applicable)	Applicant name, address & telephone: <u>Nancy Wright</u> <u>512 Island Ave</u> <u>Peaks Island 766-5615</u>	Cost Of Work: \$ <u>1900.00</u>  Fee: \$ <u>37.00</u>
Current use: <u>Restaurant / lodging</u>		
If the location is currently vacant, what was prior use: _____		
Approximately how long has it been vacant: _____		
Proposed use: <u>Same with two</u>		
Project description: <u>Gazebos for guest use</u> <u>1 16x16 Octagonal Gazebo</u> <u>1 10x10 Octagonal Gazebo</u>		
Contractor's name, address & telephone: <u>As above</u>		
Who should we contact when the permit is ready: <u>Same</u>		
Mailing address: _____		
We will contact you by phone when the permit is ready. You must come in and pick up the permit and review the requirements before starting any work, with a Plan Reviewer. A stop work order will be issued and a \$100.00 fee if any work starts before the permit is picked up. <b>PHONE: 766-5615</b>		

IF THE REQUIRED INFORMATION IS NOT INCLUDED IN THE SUBMISSIONS THE PERMIT WILL BE AUTOMATICALLY DENIED AT THE DISCRETION OF THE BUILDING/PLANNING DEPARTMENT, WE MAY REQUIRE ADDITIONAL INFORMATION IN ORDER TO APPROVE THIS PERMIT.

I hereby certify that I am the Owner of record of the named property, or that the owner of record authorizes the proposed work and that I have been authorized by the owner to make this application as his/her authorized agent. I agree to conform to all applicable laws of this jurisdiction. In addition, if a permit for work described in this application is issued, I certify that the Code Official's representative shall have the authority to enter all areas covered by this permit at any reasonable hour to enforce the provisions of the codes applicable to this permit.

Signature of applicant: <u>Nancy Wright</u>	Date: <u>3/14/13</u>
---	----------------------

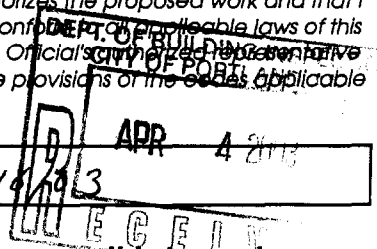

This is NOT a permit, you may not commence ANY work until the permit is issued. If you are in a Historic District you may be subject to additional permitting and fees with the Planning Department on the 4th floor of City Hall

CASCO BAY  
 HIGH-WATER LINE AS SHOWN  
 ON PLAN REFERENCE 6d. MARCH 1989.

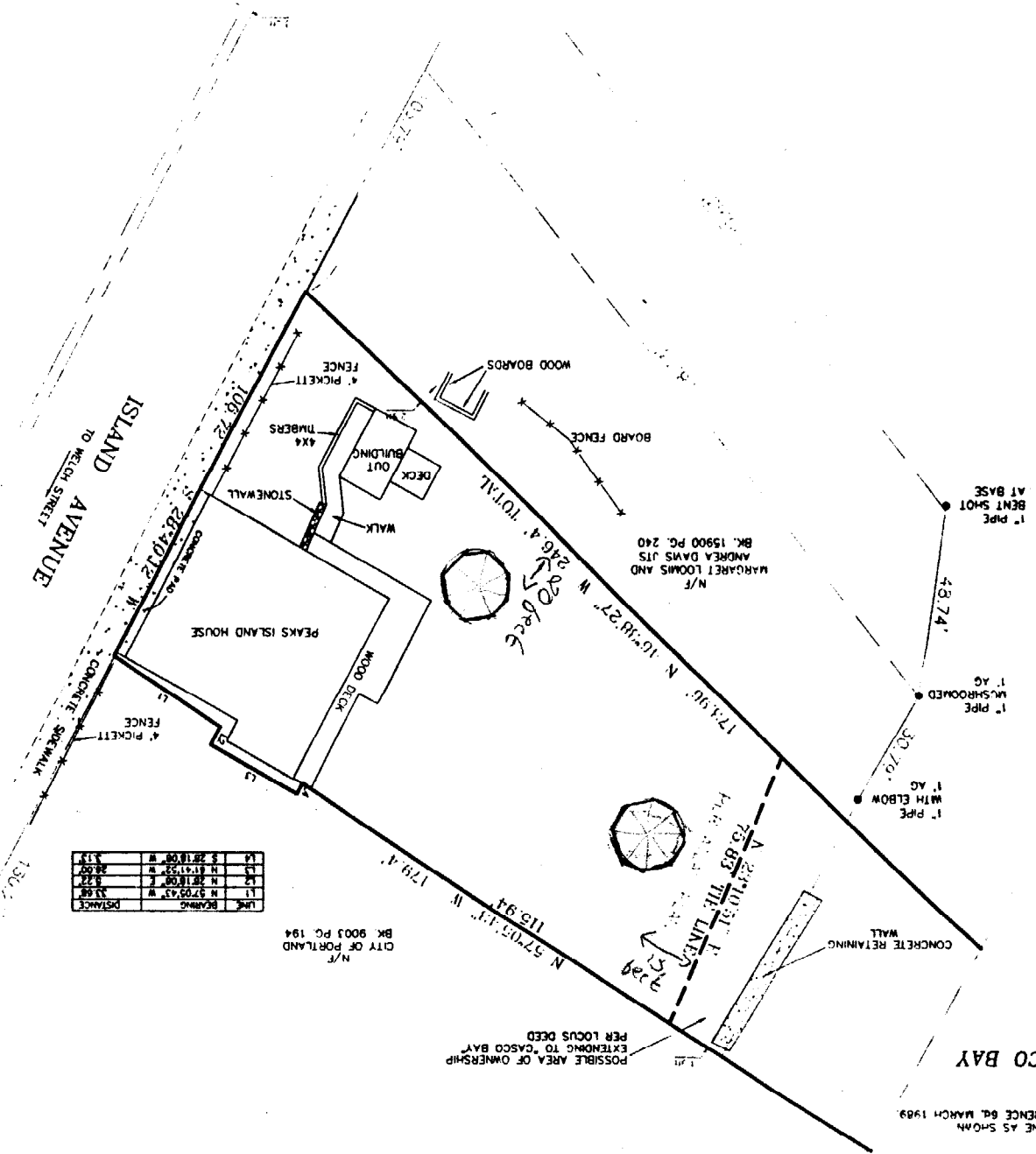

LINE	BEARING	DISTANCE
14	S 28°18'08" W	3.17
13	N 81°11'52" W	26.80
12	N 81°18'08" E	24.37
11	N 57°03'13" W	115.94

REG #1177  
 CAPPED REBAR FOUND

I-B Zone

Fence: 20' reg averaging - 20' + shown

PEAK: 10' reg - 15' shown

Side: 10' reg - 20' shown

lot coverage 50% - *AV*

# GAZEBO ASSEMBLY VIEW

OVERALL GAZEBO SIZE:

11 FT. 2 IN. WIDE (AT WIDEST POINT) x 11 FT. TALL  
(NOT INCLUDING CUPOLA & FINIAL)

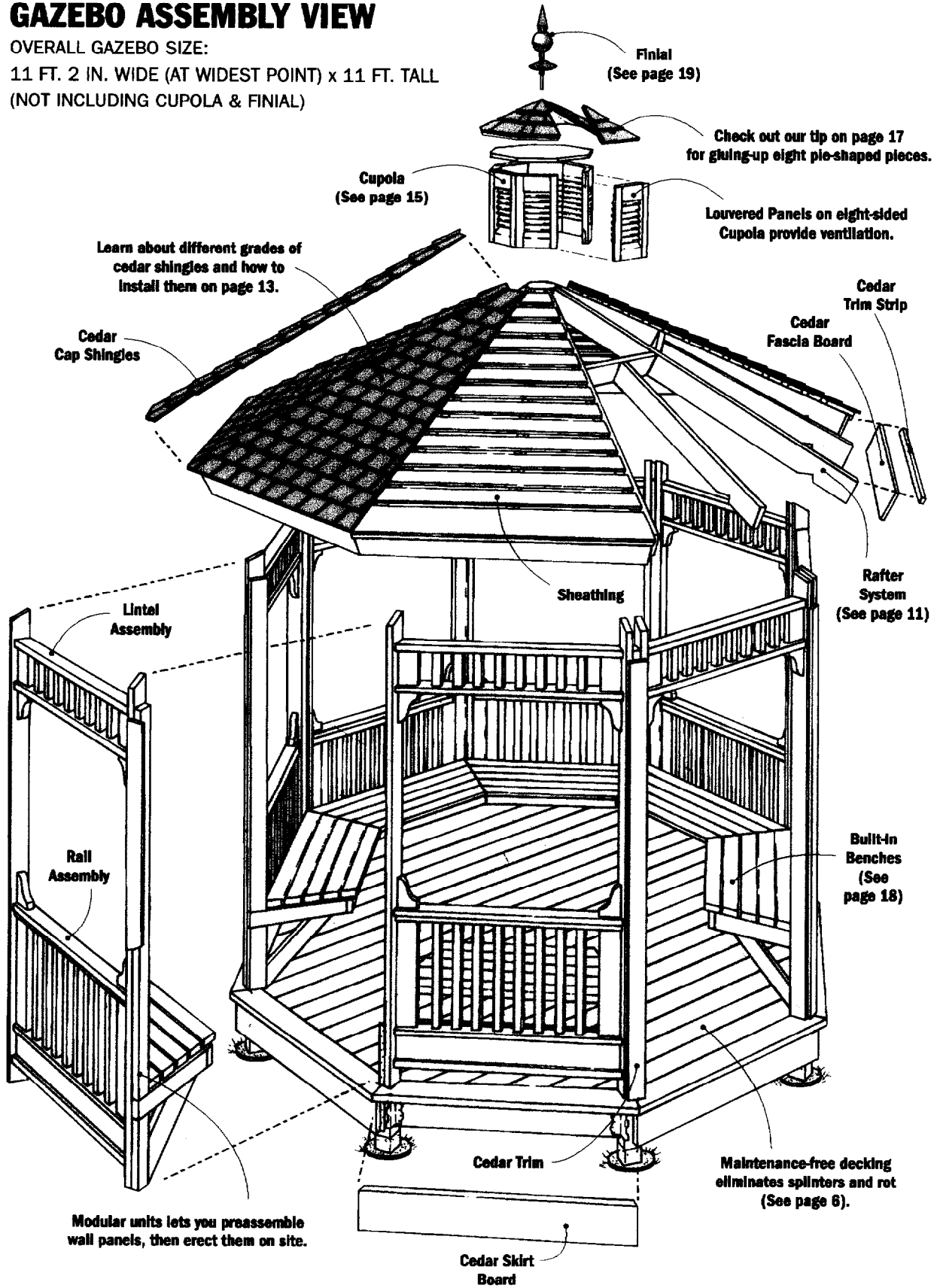

# FOUNDATION CONSTRUCTION VIEW

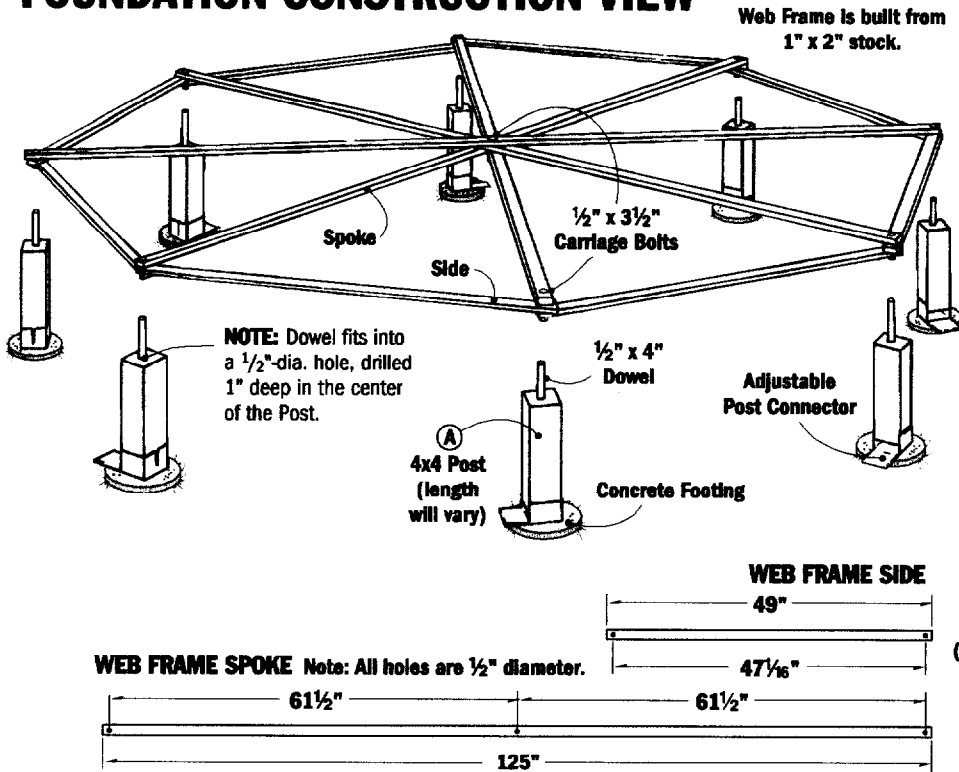

## FOOTING ANATOMY

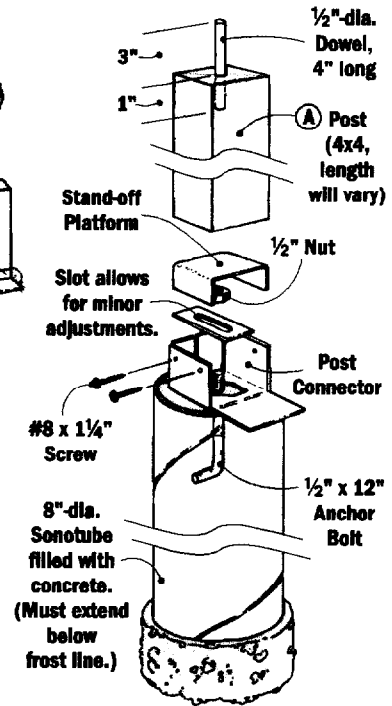

### A SOLID FOUNDATION

The foundation of the gazebo is a set of eight wood posts that rest on concrete footings (*Foundation Construction View*). The location of these posts is important. To end up with a symmetrical, eight-sided structure, the centerpoints of each adjacent pair of posts have to be the same distance apart. Plus the distance between each pair of opposing posts has to be identical, as well.

The problem is using a tape measure to accurately lay out the loca-

tions of the posts is next to impossible. What's needed is a rigid layout device to "fix" all eight hole locations.

The solution is an eight-sided wood frame that looks like a giant spider web. It consists of four long spokes and eight sides. These pieces are made from 1x2's and then bolted together to create a rigid frame.

The exact length of the frame pieces isn't critical. (I cut the spokes 125" long and made the sides 49" long.) But to ensure accurate results, take your time to carefully lay out and

drill the holes for the bolts as shown in the web frame details above.

The best way to do this is to lay out the hole locations in one spoke. Then clamp the spokes together in a stack and drill  $\frac{1}{2}$ "-dia. holes through all four pieces. I used the same technique to drill holes in the sides, working with four pieces at a time.

### FOOTINGS FOR SUPPORT

After bolting the web frame together, you can use it to lay out the location of the holes for the

## ADJUSTABLE POST CONNECTORS

To secure the wood posts to the footings on the gazebo, I used Simpson Strong-Tie connectors. This connector is adjustable, so it's easy to "fine tune" the position of the

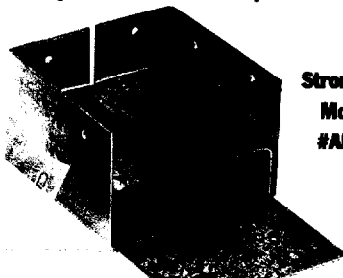

Strong-Tie  
Model  
#AB44

post. Plus it raises the post off the footings to prevent moisture from causing it to rot.

The connector consists of two parts. The lower part is a box with an adjustment hole that fits over the anchor bolt in the footing. An open flap allows you to tighten a nut against a pressure plate, which secures the connector to the footing.

The second part, the platform, fits inside the box and forms a "pocket" for the post. To secure the post, fold the flap up and screw all four sides of the box to the post.

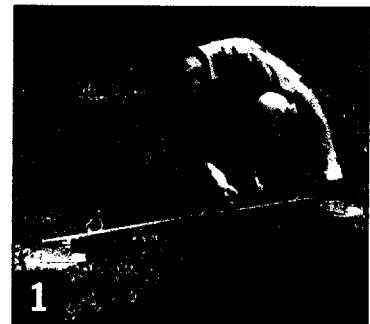

1  
Locate the "high" footing by holding a level across the post connectors and working your way around the footings.

# DECK ASSEMBLY

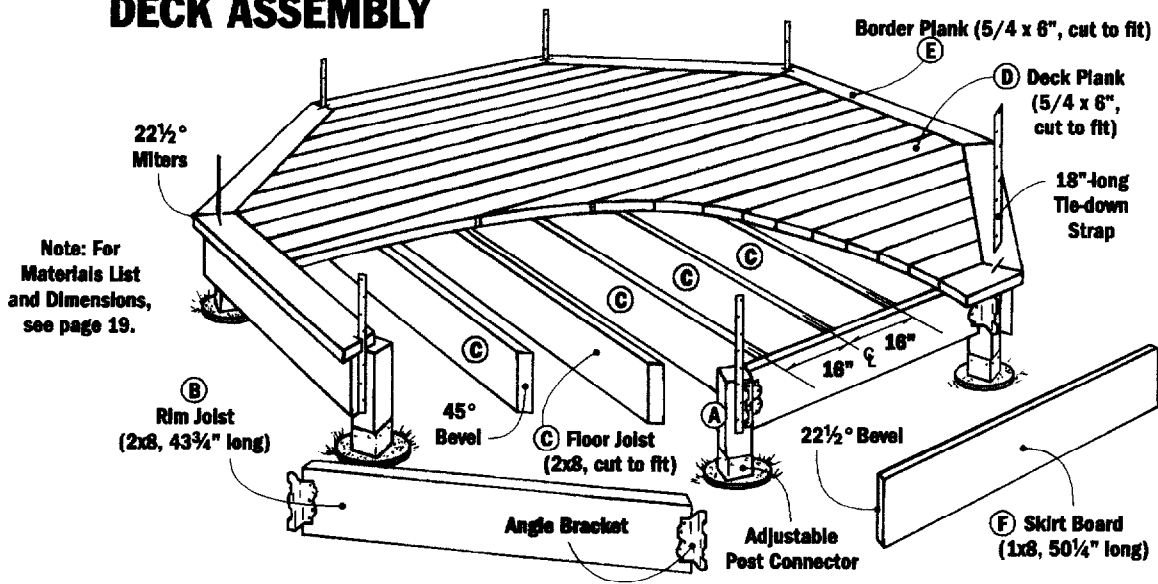

## FRAMING THE DECK

Once the posts for the foundation are set, the next step is to frame the deck of the gazebo (*Deck Assembly*).

There are eight rim joists (B) that span the posts and support the floor joists. For strength, I used 2x8's (pressure-treated pine). The rim

joists are beveled at each end (22 1/2°) to fit against the posts. But before cutting them to length, it's a good idea to cut a test joist and check its fit between each pair of posts. (Thanks to the web frame, there shouldn't be much difference.) Then cut the remaining rim joists

to length and secure them to the posts with metal angle brackets and screws (*Outside Corner Detail*).

Now you can add the floor joists (C). There are seven floor joists — three that run perpendicular to the rim joists, and four (two on each side) that meet them at a 45° angle.

It only takes a few minutes to lay out the location of the floor joists. The middle joist is centered on the length of the rim joist, and the others are set 12" apart on-center. Notice that the three full-length joists are cut square on the end and fastened to metal joist hangers (*Fig. 5*). As for the two shorter joists on each side, bevel them to length and mount them in a 45° joist hanger (*Inside Corner Detail*).

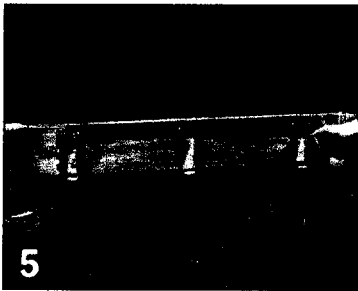

After centering the first joist hanger on the length of one of the rim joists, mount all the other hangers 12" apart.



Now draw a line centered on the thickness of the rim joists that will be used when trimming the deck planks to length.

## LAY THE DECKING

Now you're ready to lay the decking. It's made up of 1 1/4"-thick planks that



Next, tack a wood cleat on the line and use 1/8"-thick spacers to create a uniform gap between each deck plank.

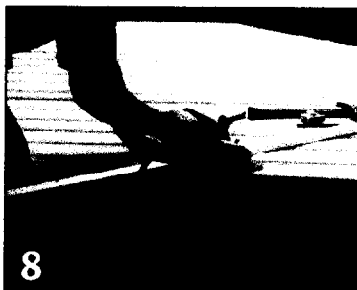

To guide the saw when cutting the deck planks, tack on a straightedge that lines up with the trim line on the rim joists.



A hand-held router and 1/8" round-over bit make quick work of routing the ends of the deck planks to match the edges.

# WALL PANEL ASSEMBLY

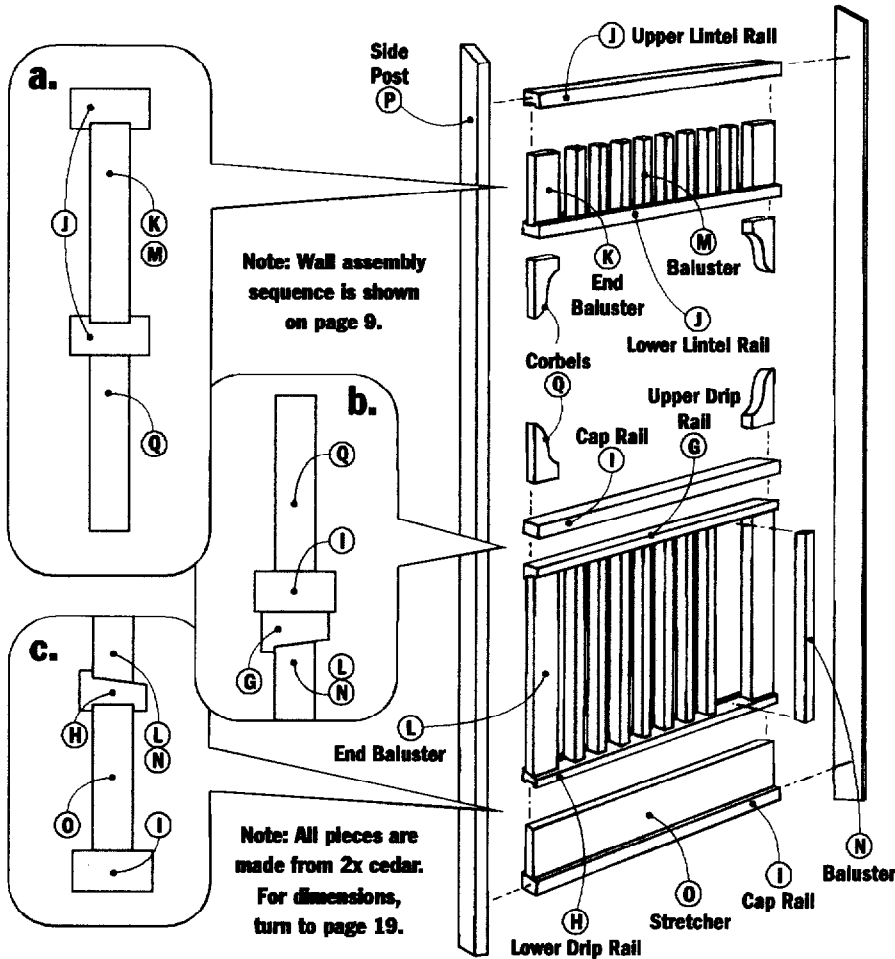

## PREFAB THE WALLS

To simplify the construction of the gazebo, it's designed with identical wall panels. This speeds things up considerably because it allows you to make all the "like" parts of each wall panel using the same tool setups. Also, you can assemble the panels in the

comfort of your shop and then erect the "prefab" walls as weather permits.

The wall panels have two main sections: a lower rail assembly and an upper lintel assembly that are connected by a pair of tall side posts (*Wall Panel Assembly*). Altogether, you'll need seven rail assemblies and eight lintel

assemblies. (There isn't a rail assembly at the entrance of the gazebo.) Note: I used cedar for the wall panels because it's resistant to rot and decay.

## MAKING THE RAILS

Each wall panel is made up of several different rails (G, H, I, and J). So take a minute to familiarize yourself with them before cutting any lumber.

If you look at the lower rail assembly, you'll see there are two drip rails (G, H) that capture a row of balusters between them. A couple of cap rails (I) form the top and bottom of this rail assembly.

As for the lintel assembly, it's much simpler. The balusters fit between an upper and lower rail (J).

The final width of these rails will vary. But to get into a "production mode," I started by ripping enough stock for all the rails to a width of 3".

Before cutting the rails to length, notice that there's a  $22\frac{1}{2}^\circ$  miter at each end. As a result, the tall side posts (which are attached to the rails) sit at a corresponding angle. When the wall panels are installed later, this produces the octagonal shape of the walls.

One thing to be aware of here is the *length* of the rails. The cap and lintel rails (I, J) are slightly longer than the drip rails (G, H).

With that in mind, tilt the head of the miter gauge on your table saw  $22\frac{1}{2}^\circ$ , as shown in *Figure 14*. (Or, use a power miter saw instead.) Then miter all the rails to final length.

At this point, the cap rails (I) are complete, so set them aside. But the remaining rails still need some work.

To see what I mean, take a look at the *Wall Panel Assembly* again and also *Detail 'a'*. Notice that the balusters in the lintel assembly fit into grooves in the upper and lower rails (J). A dado blade mounted in the table saw makes quick work of cutting these grooves (*Fig. 15*).

You'll also need to cut an identical groove in the *lower drip rail* only (*Detail 'c'*). This groove fits over a stretcher that's added later.

With the groove complete, the next step is to rip the drip rails to width. This is pretty straightforward

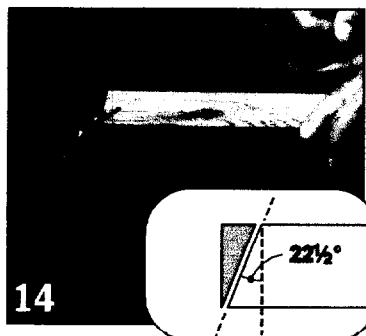

**14** Miter both ends of the 2x4 rail blanks at  $22\frac{1}{2}^\circ$ . Eventually, this will allow the wall panels to form an octagon.

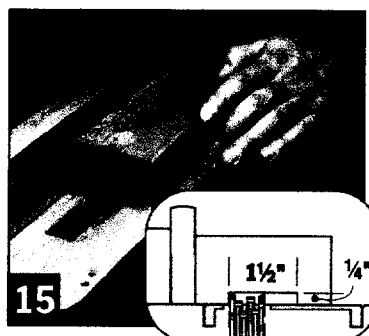

**15** To accept the balusters in the lintel (and to fit over the stretcher), cut a centered groove in rails (H) and (J).

# WALL ASSEMBLY SEQUENCE

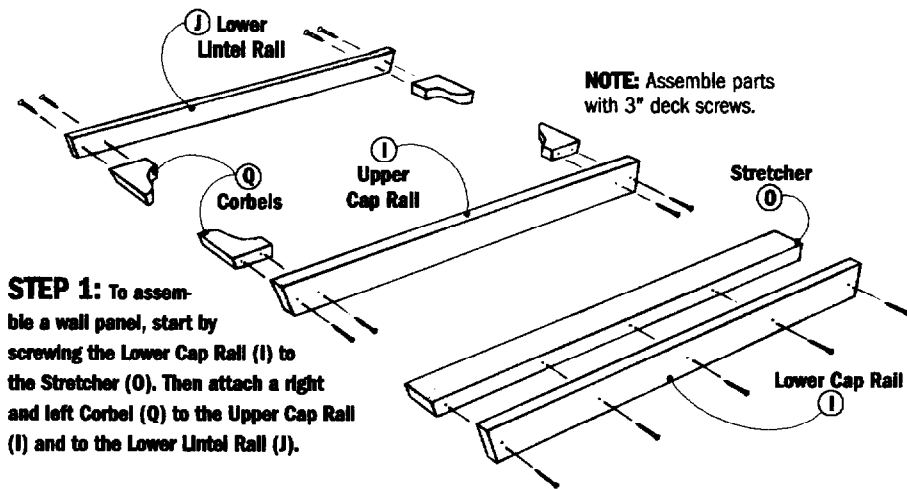

**STEP 1:** To assemble a wall panel, start by screwing the Lower Cap Rail (I) to the Stretcher (O). Then attach a right and left Corbel (Q) to the Upper Cap Rail (I) and to the Lower Lintel Rail (J).

**NOTE:** Assemble parts with 3" deck screws.

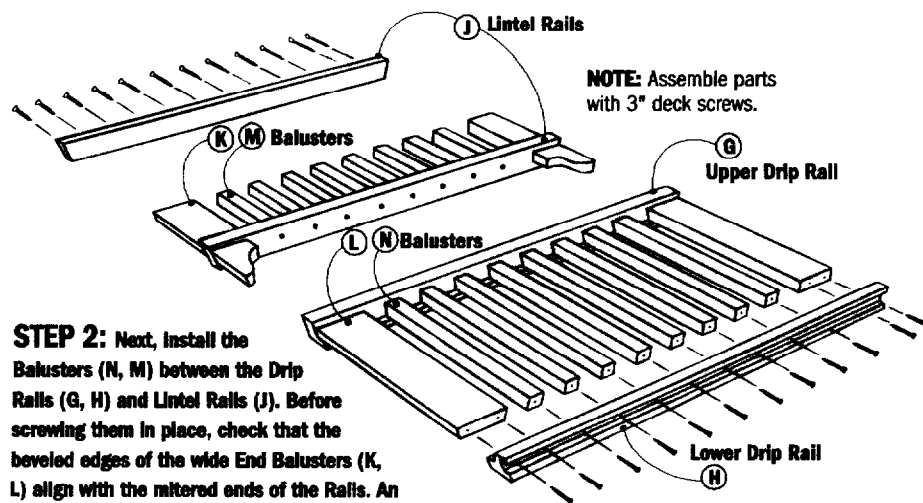

**STEP 2:** Next, install the Balusters (N, M) between the Drip Rails (G, H) and Lintel Rails (J). Before screwing them in place, check that the beveled edges of the wide End Balusters (K, L) align with the mitered ends of the Rails. An assembly jig will ensure the Balusters are spaced evenly (2½") apart.

**NOTE:** Assemble parts with 3" deck screws.

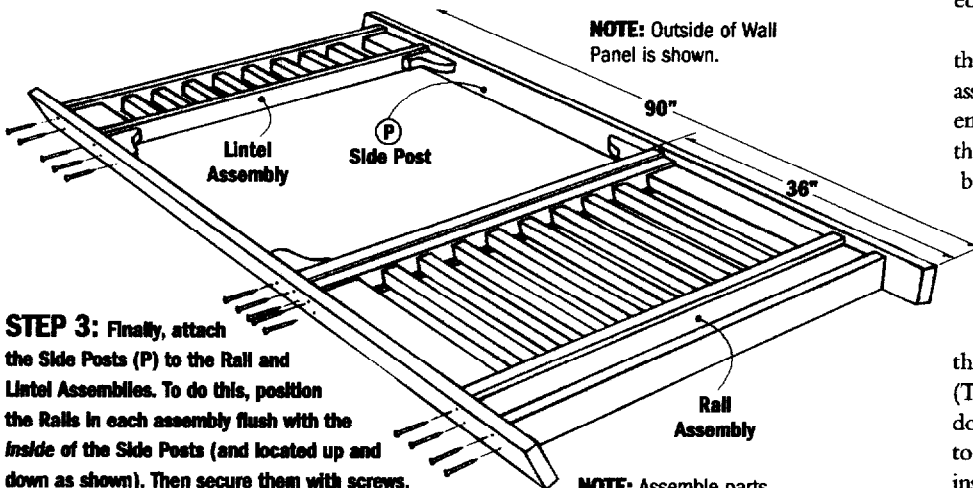

**STEP 3:** Finally, attach the Side Posts (P) to the Rail and Lintel Assemblies. To do this, position the Rails in each assembly flush with the inside of the Side Posts (and located up and down as shown). Then secure them with screws.

**NOTE:** Outside of Wall Panel is shown.

**NOTE:** Assemble parts with 3" deck screws.

## PUT THE PANELS TOGETHER

Assembling the panels is easy, especially if you use the step-by-step sequence shown here. To prevent twisting or racking, assemble them on a flat area like the garage floor or driveway.

The first step is to center the lower cap rail (I) on the width of the stretcher (O), as shown in *Step 1*. Then just screw the rail in place.

Next, attach a right and a left corbel (Q) to the upper cap rail (I) and also to the lower lintel rail (J). Center the corbels on the width of the rails, and position their beveled edges flush with the ends of the rails.

Now you're ready to install the two rows of balusters in each wall panel (*Step 2*). To ensure even spacing (and to speed up the assembly process), I used a jig made from scrap 1x4's.

To complete the rail assembly, fit the groove in the lower drip rail down over the stretcher and tack in a couple of nails. (I used 8d galvanized casing nails.) This will hold it in place until the side posts are attached.

You'll also need to add the upper cap rail (the one with the corbels) and tack it in place. To keep the nails from showing, I drove nails at an angle from the drip rail up into the cap rail.

All that's needed to complete each wall panel is to attach the side posts (P) to the lintel and rail assemblies (*Step 3*). The idea is to position each assembly flush with the inside edge of the posts.

As for the up and down location, there's nothing critical about the rail assembly. (I set it 36" above the lower end of the posts.) But the location of the lintel assembly is important. That's because the roof rafters rest on it. So to establish the proper roof pitch, I screwed it in place as shown (90" from the bottom of the posts).

Now just repeat the process for the remaining six wall panels. (There's no rail assembly in the doorway, just a lintel.) You may want to save the two straightest posts and install these on the lintel-only section. They're the most visible, and you want the best looking posts here.



## MAKING THE CONNECTION

With most projects, you reach a point where it really starts to take shape. For this gazebo, that time is now — when you begin to connect the wall panels to each other.

To create the appearance of a thick post at each corner, the wall panels are connected by two 2x spacer blocks ripped 3" wide (*Corner Connection*). A short (R) and a long spacer block (S) are sandwiched between the side posts of two adjacent wall panels.

Notice that there's a 3½"-tall opening between the two blocks. This opening creates a "pocket" that will eventually hold a bench support.

One more thing to be aware of is that the long spacer block acts as a support for the hip rafters on the roof. So to ensure proper roof pitch, it's important that the upper end of this block is even with the top of the lintel.

After cutting the spacer blocks to length, you can attach them to the side posts. To avoid having two sets of spacer blocks come together, I made it a point to screw them to the *left* side post of each wall panel (as viewed from the front). Shop Tip: Insert a scrap 2x4 between the blocks to produce the proper size pocket.

## UP WITH THE WALLS

Before installing the wall panels, I'd suggest rounding up a friend to provide a helping hand. The large panels can be heavy and awkward to handle.

To erect the walls, start to the left side of where the doorway for the

gazebo will be located. Then lift the first wall panel and set it on the deck. While your helper holds it upright, slide a second wall panel against it and clamp them together at the corner. The panels are fastened together by "toenailing" screws through the spacer blocks and into the side post of the adjacent wall. (See *Figure 19* and *Post Detail* below.) Continue like this, working your way around the gazebo, installing one wall at a time.

The next step is to "anchor" the walls to the deck by fastening them to the metal tie-down straps. To do this, tap the walls into place so the short spacer block (R) is centered on the strap. Then drive screws through the strap into the spacer block (*Fig. 20*).

With the walls in place, stand back and take a minute to admire the gazebo before starting on the roof (*Fig. 21*).

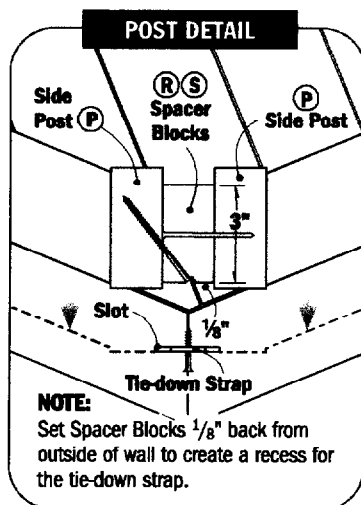

## CORNER CONNECTION

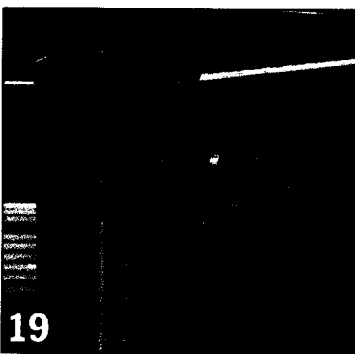
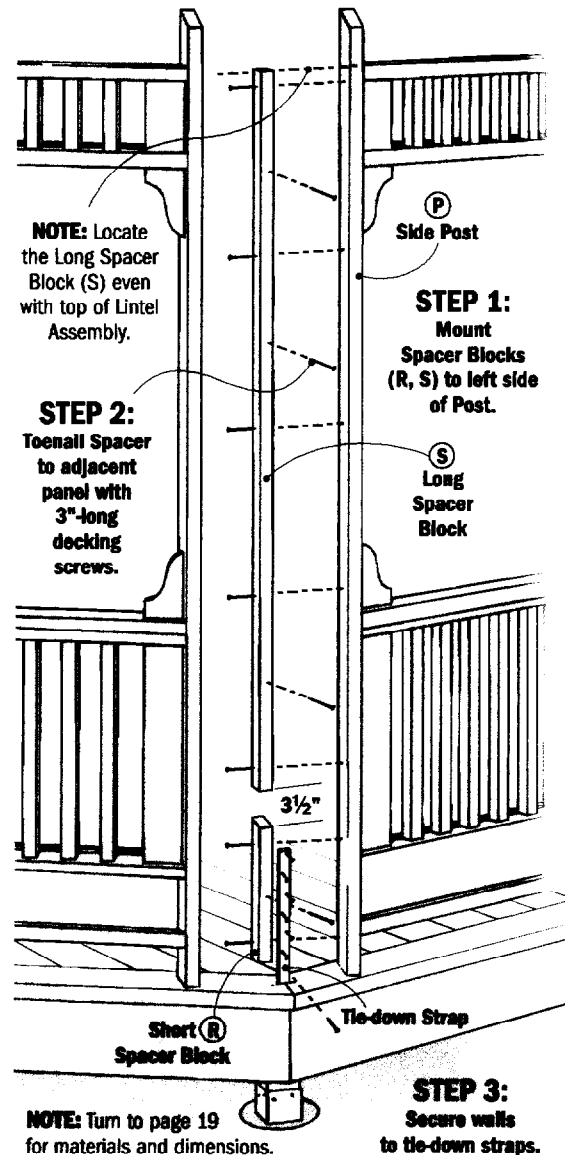

19

To fasten two wall panels together, "toenail" screws at an angle through the spacer blocks and into the post.

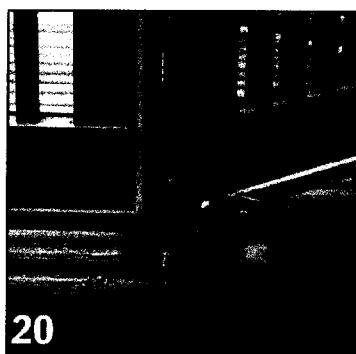

20

With the wall panels in their final position, screw the tie-down straps to the spacer blocks (R) at all eight corners.

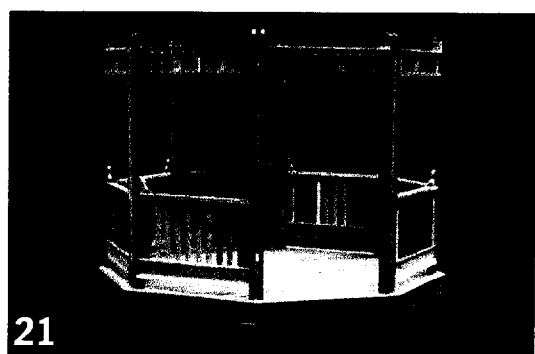

21

With the eight wall panels fastened in place, the gazebo really begins to take shape. At this point, you're ready to begin building the roof.

# RAFTER ASSEMBLY

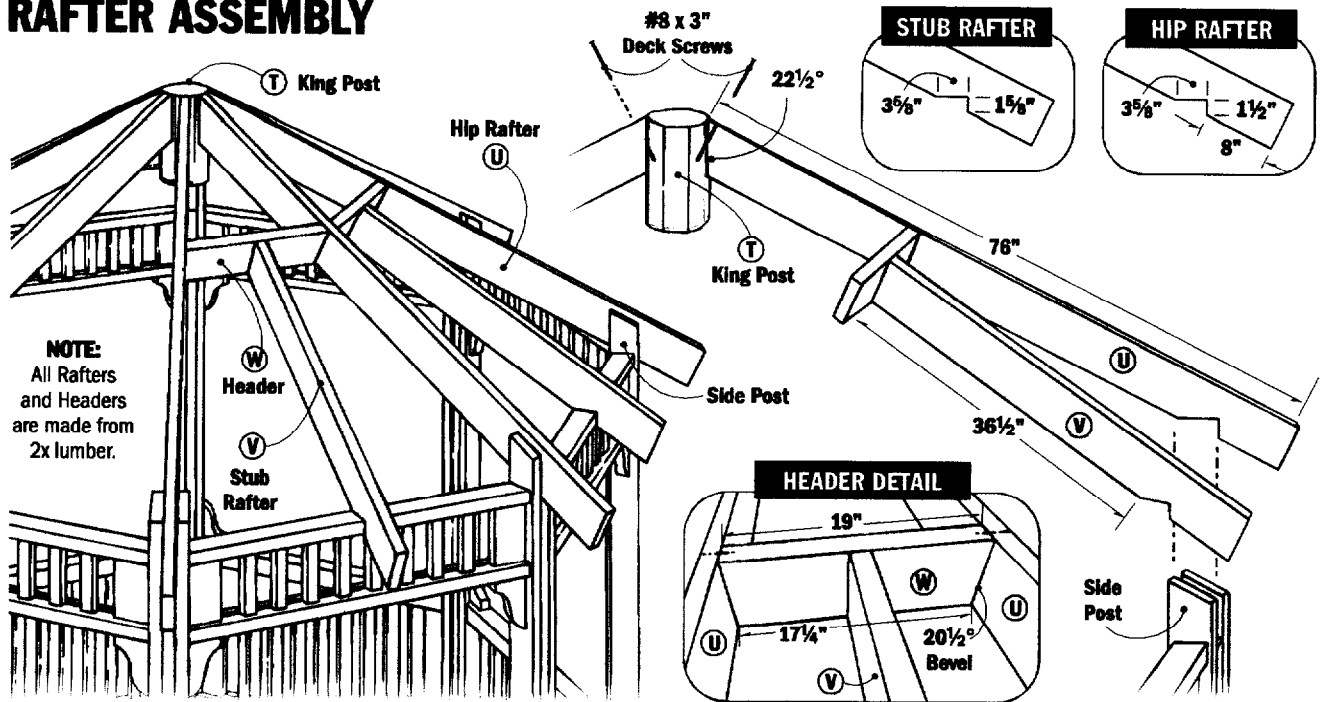

## RULES FOR RAFTERS

With the walls complete, it's time to add the roof rafters. There are eight long hip rafters that fit into saddles formed by the side posts of the walls (*Rafter Assembly*). These hip rafters connect to a large, eight-sided block called a king post. There are also eight short stub rafters that "tie" into headers, which span across the hip rafters.

## FIT FOR A KING POST

I began by making the thick, eight-sided king post (T) that forms the hub of the rafter system (*King Post Detail*). It is made up of four 2x8 cedar blocks ripped to a width of 6 1/4" and glued together. (I used

polyurethane glue for a waterproof bond.) Once the glue dries, joint all four sides to make a 6"-square block.

The next step is to lay out the eight sides of the king post. The goal is to end up with eight sides that are equal in size. To do this, locate the centerpoint of the post by drawing diagonal lines from corner to corner (*Drawing 'a'*). Then set the tip of a compass at the centerpoint and draw a circle that just touches all four sides.

The intersecting points (where the compass arc crosses the diagonals) are used to lay out the angled corners of the block. Set the 45° side of a combination square against the block. Then align the blade with each point

and draw a line across the corner. To bevel the corners of the post, tilt the blade on your table saw to 45° (*Drawing 'b'*). Then set the rip fence so the blade aligns with the layout line and bevel the first corner. Now trim the remaining corners, rotating the post 90° between each pass.

Finally, since the king post will be exposed inside the gazebo, I routed a decorative 1/2" roundover around the bottom edge (*Drawing 'c'*).

## READY FOR THE RAFTERS

With the king post completed, it's time to add the roof rafters. Note: I used 2x6's (cedar) for all the rafters and headers.

## KING POST DETAIL

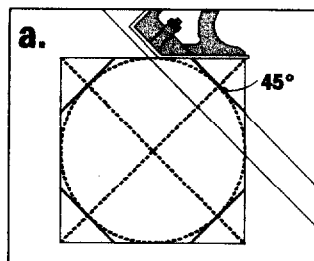
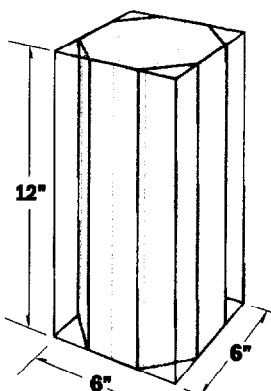

To lay out the king post's angled sides, mark across the corners (where arc crosses diagonals).

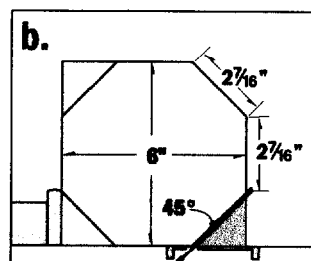

Tilt the blade to 45° and adjust the fence to line up the cut. After each cut, rotate the block 90°.

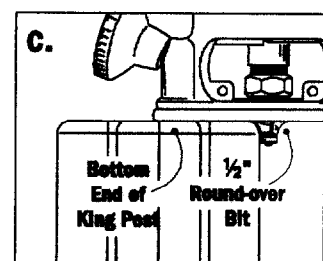

Route a 1/2" roundover around the bottom of the king post to give the exposed part a finished look.

## SHEATHING & SHINGLES

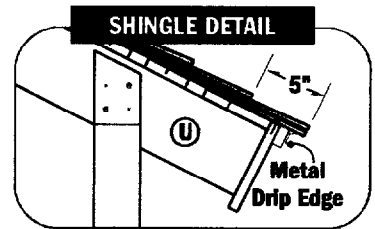
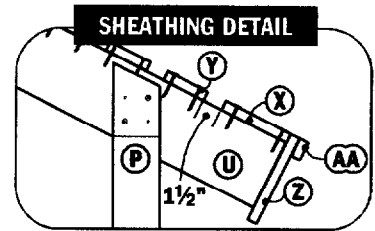
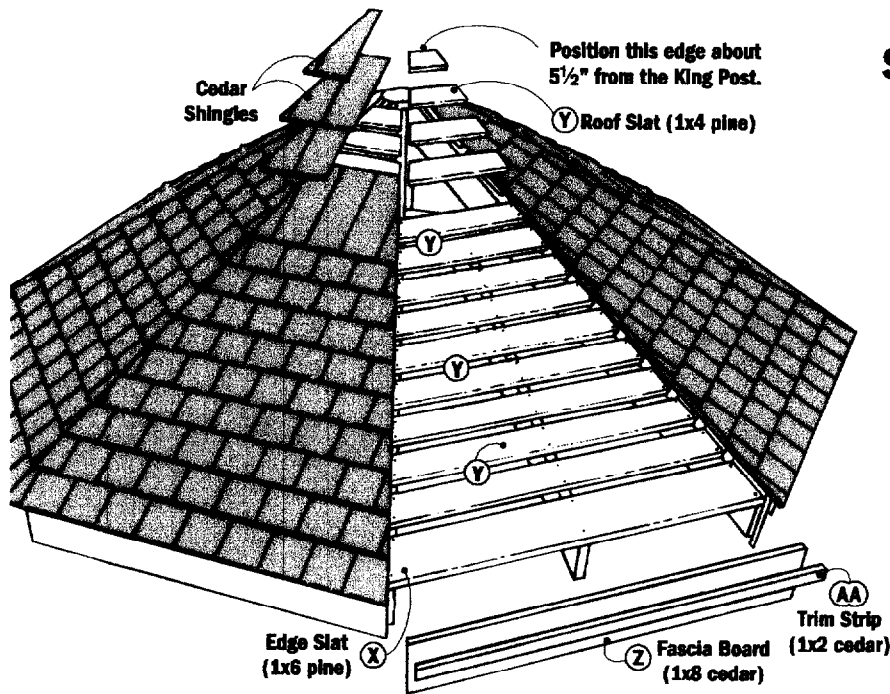

Tack a 1x6 edge slat (X) to the rafters, aligning it flush with the ends of the rafter tails.

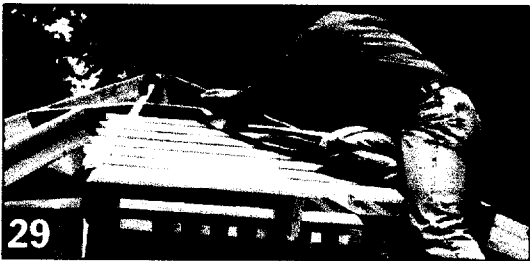

Tack 1x4 roof slats (Y) in place, leaving them extra long on each end. Use a chalkline to mark them to length.

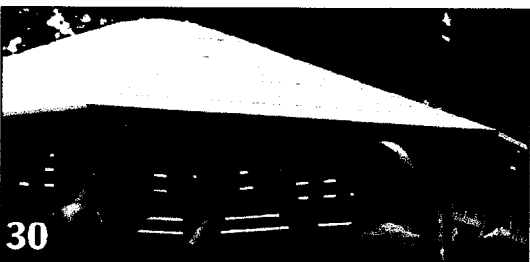

Hold a 1x8 fascia (Z) against the rafters and mark the compound angle needed. Fit each board to the previous one.

### SHEATH THE ROOF

The roof of the gazebo is covered with cedar shingles that are nailed to evenly-spaced wood slats. The space between the slats allows air to circulate so the shingles can dry out between rains.

To provide ample nailing surface for the starter course of shingles, I used a 1x6 for the edge slat (X), as shown in *Figure 28*. With the edge slat in place, tack on 1x4 roof slats (Y), letting the ends run past the hip line (*Fig. 29* and box below). Note: I nailed the slats at the hip and stub rafters with 5d galvanized box nails.

The last roof slat (the one nearest the peak) should stop about 5½" from the edge of the king post. This will leave space for air to circulate up into the cupola. With the slats in place, snap a chalkline down the center of each hip and

then trim the slats to length. You can measure the slats on the first roof section to cut identical slats for the seven remaining sections.

### CUSTOM FIT THE FASCIA

The edge of the roof is wrapped with 1x8 cedar fascia boards (Z) and a 1x2 trim strip (AA) as shown in the *Sheathing Detail*. The fascia attaches to the ends of the rafters, while the trim strip keeps the drip edge away from the fascia board.

Because the ends of the rafters tip inward, the ends of the fascia are mitered *and* beveled — the second compound angle in the gazebo. Here's an easy way to determine this angle. Hold an extra-long fascia board against the rafters (*Fig. 30*), and mark the rafter centerline at the top and bottom of the fascia board. Take the board down and draw a

### SKILL BUILDER

While installing the sheathing, I used a spacer like the one shown here to ensure proper spacing between the slats. It's made of two pieces of 1½"-wide stock that are screwed together to form an "X". The shape keeps the spacer from "falling through the cracks."

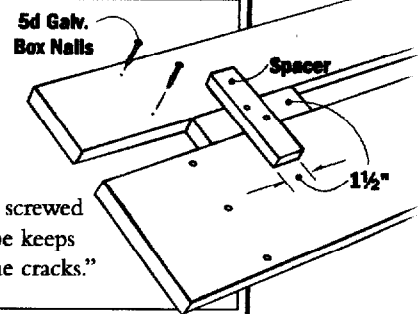

**City of Portland, Maine - Building or Use Permit**

389 Congress Street, 04101 Tel: (207) 874-8703, Fax: (207) 874-8716

<b>Permit No:</b> 03-0302	<b>Date Applied For:</b> 04/04/2003	<b>CBL:</b> 084 R032001
------------------------------	--	----------------------------

<b>Location of Construction:</b> 20 Island Ave	<b>Owner Name:</b> W & W Inc	<b>Owner Address:</b> 498 Island Ave	<b>Phone:</b> ( ) 766-4400
<b>Business Name:</b>	<b>Contractor Name:</b> Applicant	<b>Contractor Address:</b> Portland	<b>Phone:</b>
<b>Lessee/Buyer's Name</b>	<b>Phone:</b>	<b>Permit Type:</b> Additions - Commercial	

<b>Proposed Use:</b> Restaurant/Lodging	<b>Proposed Project Description:</b> Addition of One 16'x16' Octagonal Gazebo and One 10'x10' Octagonal Gazebo
--	---

**Dept:** Zoning      **Status:** Approved      **Reviewer:** Marge Schmuckal      **Approval Date:** 05/06/2003  
**Note:**      **Ok to Issue:**

**Dept:** Building      **Status:** Approved with Conditions      **Reviewer:** Mike Nugent      **Approval Date:** 05/06/2003  
**Note:**      **Ok to Issue:**

1) Approved based on the submissions which show grade to be less than 1 foot below the deck walking surface.

**Dept:** Fire      **Status:** Approved      **Reviewer:** Lt. McDougall      **Approval Date:** 05/06/2003  
**Note:**      **Ok to Issue:**

DISPLAY THIS CARD ON PRINCIPAL FRONTAGE OF WORK

# CITY OF PORTLAND

## BUILDING INSPECTION

# PERMIT

Permit Number: 030302

Please Read Application And Notes, If Any, Attached

This is to certify that W & W Inc/Applicant

has permission to Addition of One 16'x16' Octagonal Gazebo and One 10'x10' Octagonal Gazebo

AT 20 Island Ave PI 084 R032001

provided that the person or persons, firm or corporation accepting this permit shall comply with all of the provisions of the Statutes of Maine and of the Ordinances of the City of Portland regulating the construction, maintenance and use of buildings and structures, and of the application on file in this department.

Apply to Public Works for street line and grade if nature of work requires such information.

Notification of inspection must be given and written permission procured before this building or part thereof is altered or otherwise used-in. HOUR NOTICES REQUIRED.

A certificate of occupancy must be procured by owner before this building or part thereof is occupied.

### OTHER REQUIRED APPROVALS

Fire Dept. [Signature]

Health Dept. \_\_\_\_\_

Appeal Board \_\_\_\_\_

Other \_\_\_\_\_

Department Name

[Signature] 5/6/03  
Director - Building & Inspection Services

**PENALTY FOR REMOVING THIS CARD**