

4 ENLARGED APT#4 BATH PLAN  
1/4"=1'-0"

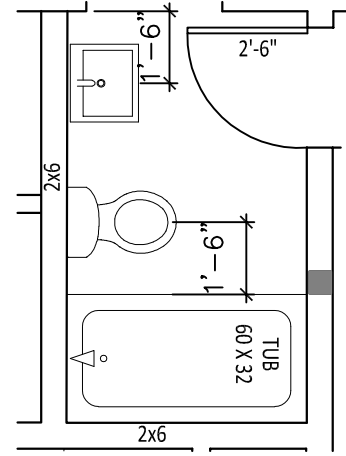

4 ENLARGED APT#4 MASTER BATH PLAN  
1/4"=1'-0"

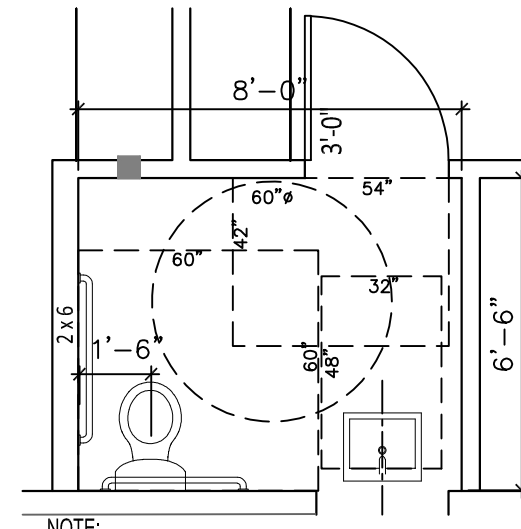

3 ENLARGED OFFICE ADA TLT RM PLAN  
1/4"=1'-0"

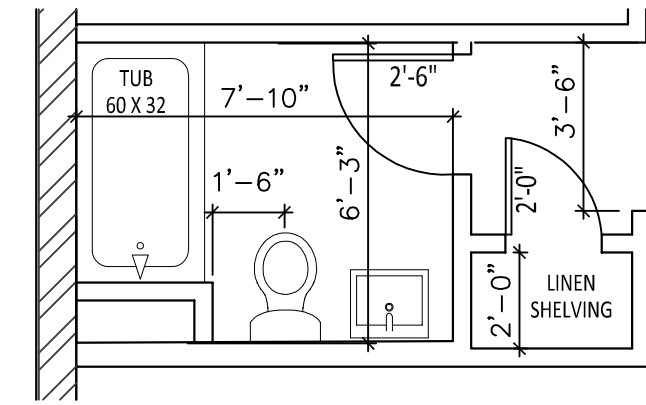

2 ENLARGED APT#1 BATH PLAN  
1/4"=1'-0"

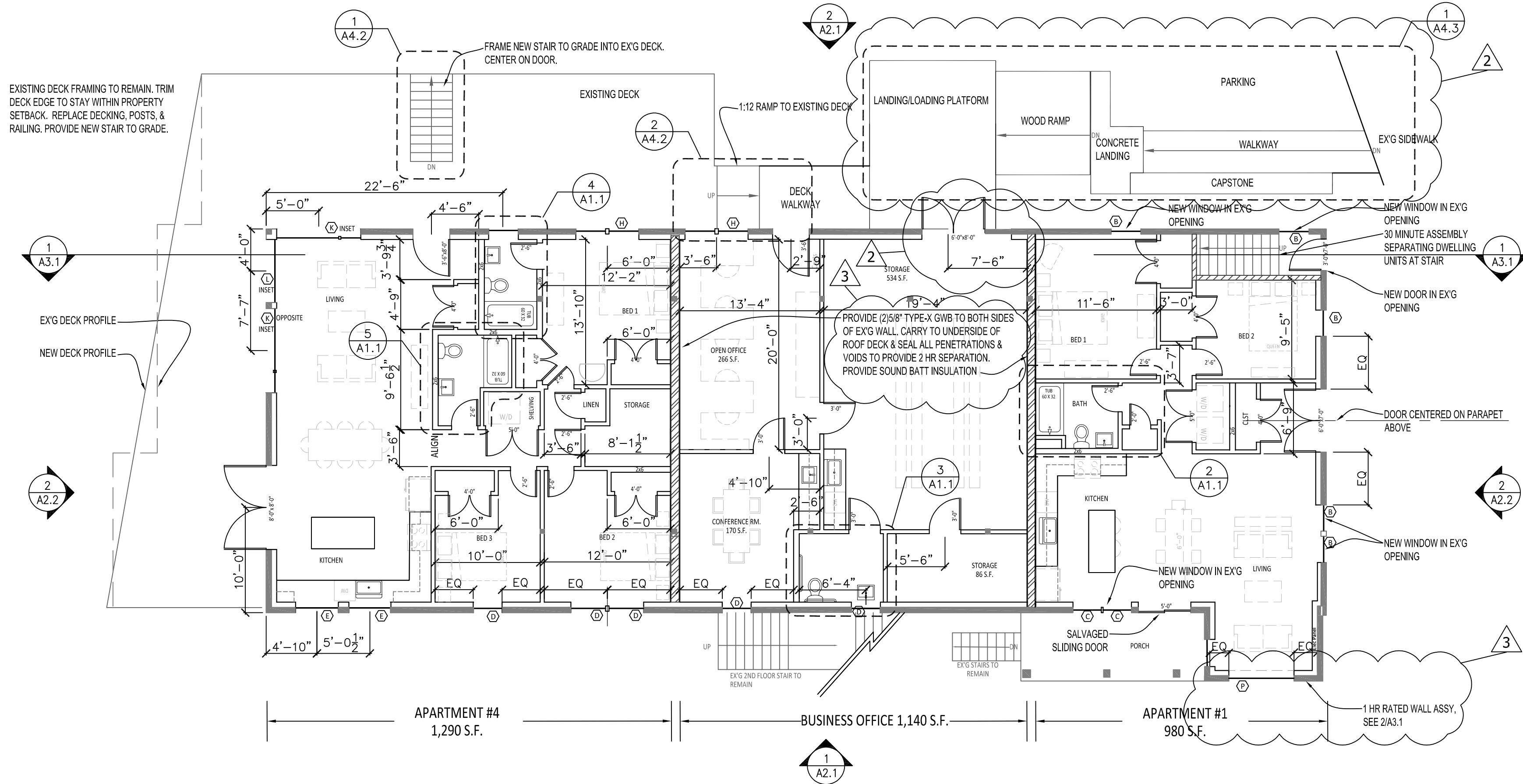

PARTITION TYPES KEY	
	EXISTING TO REMAIN
	NEW PARTITION
	2 HR ASSEMBLY
	1/2 HR ASSEMBLY

FLOOR PLAN NOTES	
•	DIMENSIONS TO FINISH FACE OF WALL & CENTERLINE OF DOORS & WINDOWS.
•	CLOSETS 2'-0" CLEAR INSIDE, TYP.
•	DOOR HINGE JAMB 4" FROM CORNER, TYP, U.N.O.

1 FIRST FLOOR PLAN  
1/8"=1'-0"

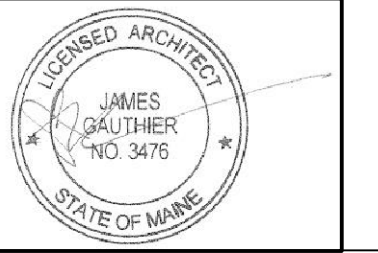

Rachel Conly Design LLC  
26 Sterling Street  
Peaks Island, Maine 04108  
207.766.5625  
www.rachelconlydesign.com

DATE	NOTES
2017.12.29	ISSUED FOR PERMIT
2018.01.16	1 TWO HOUR GROUP SEPARATION
2018.02.02	2 REVISED SITE - WALKWAY & RAMP
2018.02.22	3 SEPARATION DTLS & 1HR RATING @ SOUTH WALL

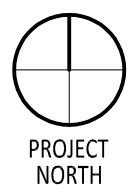

PROJECT NORTH

2 Island Ave.  
Peaks Island, ME

PROJECT

FIRST FLOOR PLAN

A1.1