

SKIRT BOARD / FROST PROTECTION

1" = 1'

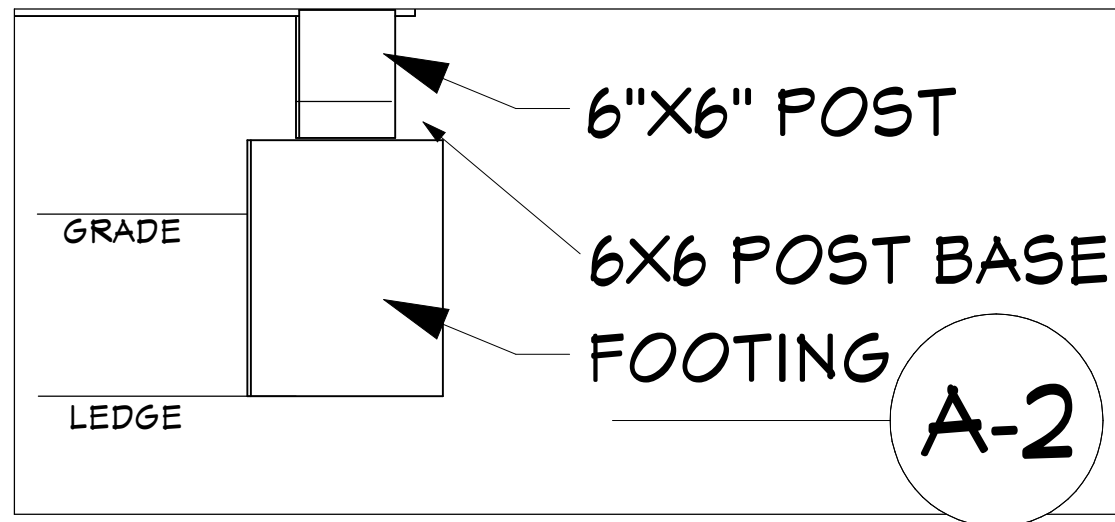

POST / FOOTING DETAIL

1" = 1'

Door Schedule									
Number	Label	Qty	Floor	Size	Width	Height	R/O	Description	Header
D01	2668	1	1	2668 L IN	30 "	80 "	32"x82 1/2"	Hinged-Door P04	2x6x35" (2)
D02	3068	1	1	3068 L EX	36 "	80 "	38"x83"	ext. Hinged-Door E02	2x6x41" (2)
D03	6068	1	1	6068 R EX	72 "	80 "	74"x83"	ext. Slider-Glass	2x10x77" (2)

Window Schedule										
Number	Label	Qty	Floor	Size	Width	Height	R/O	Egress	Description	Header
W01	2340DH	1	1	2340DH	27 "	48 "	28"x49"		Double Hung	2x6x31" (2)
W02	2621AW	3	1	2621AW	30 "	25 "	31"x26"		Awning	2x6x34" (2)
W03	2640DH	1	1	2640DH	30 "	48 "	31"x49"		Double Hung	2x6x34" (2)
W04	5640DC	1	1	5640DC	66 "	48 "	67"x49"		Dbl Casement-lhl/rhr	2x8x70" (2)

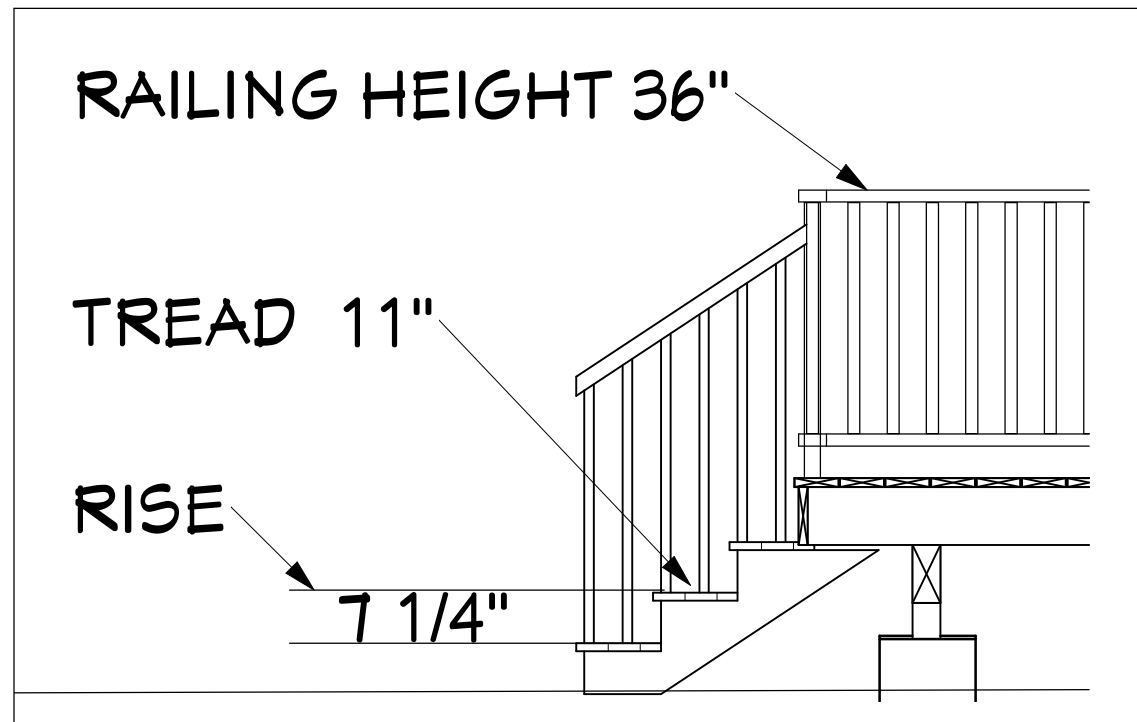

STAIR DETAIL

1/2" = 1'

REVISION TABLE	NUMBER	DATE	REVISION BY	DESCRIPTION

CLIENT: KEVIN CARTER
2-4 OAK STREET PEAKS ISLAND ME
REBUILD BUNK HOUSE

DRAWINGS PROVIDED BY:
MCTIGUE CONSTRUCTION

DATE:
5/7/2017
SCALE:
SHEET:
P-10