

Certificate of Occupancy

LOCATION 29 Spring Cove Ln

CBL 083E A031001

Issued to Rickaby Ryan A / TBD

Date of Issue 05/20/2010

This is to certify that the building/premises, or part thereof, at the above location, built — altered — changed as to use under Building Permit No. 05-0947 *has had final inspection, has been found to conform substantially to requirements of Zoning Ordinance and Building Code of the City, and is hereby approved for occupancy or use, limited or otherwise as indicated below.*

PORTION OF BUILDING OR PREMISES

Entire Dwelling

APPROVED OCCUPANCY

Use Group R-3
Type 5B
IRC 2003

MAIL
New Hampshire

Address

Limiting Conditions:

This certificate supersedes certificate issued

Approved:

5-20-10
(Date)

[Handwritten signatures and stamps]

DISPLAY THIS CARD ON PRINCIPAL FRONTAGE OF WORK CITY OF PORTLAND

Please Read Application And Notes, If Any, Attached

PERMIT ISSUED
Permit Number: 050947
AUG 31 2005
CITY OF PORTLAND

CONSTRUCTION

PERMIT

This is to certify that Rickarby Ryan & /TBD
has permission to Summer cottage 3 bedrooms /12 Bath
AT 29 Spring Cove Ln O 083E A031001

provided that the person or persons, firm or corporation accepting this permit shall comply with all of the provisions of the Statutes of Maine and of the ordinances of the City of Portland regulating the construction, maintenance and use of buildings and structures, and of the application on file in this department.

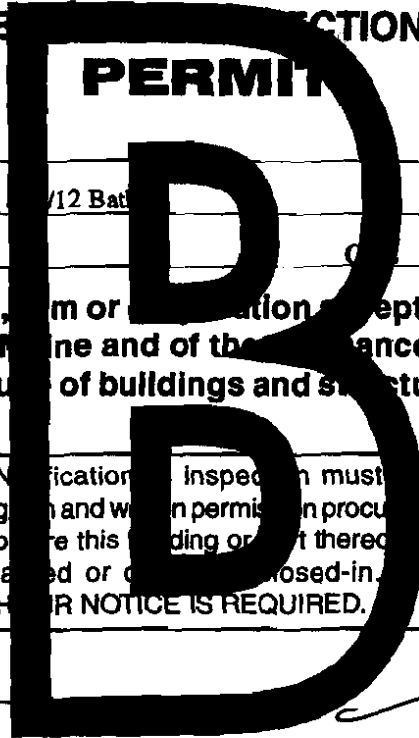

Apply to Public Works for street line and grade if nature of work requires such information.

Notification of inspection must be given and when permission is procured before this building or part thereof is occupied or closed-in. **24 HOUR NOTICE IS REQUIRED.**

A certificate of occupancy must be procured by owner before this building or part thereof is occupied.

OTHER REQUIRED APPROVALS

Fire Dept. _____
Health Dept. _____
Appeal Board _____
Other _____
Department Name

[Handwritten Signature]
8/31/05
Director - Building & Inspection Services

PENALTY FOR REMOVING THIS CARD

City of Portland, Maine - Building or Use Permit Application

389 Congress Street, 04101 Tel: (207) 874-8703, Fax: (207) 874-8716

Permit No:	PERMIT ISSUED	
05-0947		083E A01001

Location of Construction: 29 Spring Cove Ln	Owner Name: Rickarby Ryan &	Owner Address: 3 Country Farm Rd	Issue Date: AUG 31 2005	Phone: 603-772-4446
Business Name:	Contractor Name: TBD	Contractor Address: Portland	CITY OF PORTLAND	
Lessee/Buyer's Name	Phone:	Permit Type: Single Family	Zone: IR-1	

Past Use: Vacant Land	Proposed Use: Summer cottage 3 bedrooms & 2/12 Baths	Permit Fee: \$2,346.00	Cost of Work: \$250,000.00	CEO District: 1
Proposed Project Description: Summer cottage 3 bedrooms & 2/12 Baths		FIRE DEPT: <input type="checkbox"/> Approved <input checked="" type="checkbox"/> Denied <i>NA</i>	INSPECTION: Use Group: <i>R-3</i> Type: <i>SB</i> <i>IRC 2003</i>	
		Signature:	Signature:	
PEDESTRIAN ACTIVITIES DISTRICT (P.A.D.)				
Action: <input type="checkbox"/> Approved <input type="checkbox"/> Approved w/Conditions <input type="checkbox"/> Denied				
Signature: _____ Date: _____				

Permit Taken By: ldobson	Date Applied For: 07/11/2005	Zoning Approval		
-----------------------------	---------------------------------	------------------------	--	--

<p>1. This permit application does not preclude the Applicant(s) from meeting applicable State and Federal Rules.</p> <p>2. Building permits do not include plumbing, septic or electrical work.</p> <p>3. Building permits are void if work is not started within six (6) months of the date of issuance. False information may invalidate a building permit and stop all work..</p>	<p>Special Zone or Reviews</p> <p><input checked="" type="checkbox"/> Shoreland <i>house is over 160' from HWY</i></p> <p><input type="checkbox"/> Wetland</p> <p><input type="checkbox"/> Flood Zone <i>panel 9 zone</i></p> <p><input type="checkbox"/> Subdivision</p> <p><input checked="" type="checkbox"/> Site Plan <i>2005-0155</i></p> <p>Maj <input type="checkbox"/> Minor <input type="checkbox"/> MM <input checked="" type="checkbox"/></p> <p><i>ok with conditions</i></p> <p>Date: <i>8/8/05</i></p>	<p>Zoning Appeal</p> <p><input type="checkbox"/> Variance</p> <p><input type="checkbox"/> Miscellaneous</p> <p><input type="checkbox"/> Conditional Use</p> <p><input type="checkbox"/> Interpretation</p> <p><input type="checkbox"/> Approved</p> <p><input type="checkbox"/> Denied</p> <p>Date: _____</p>	<p>Historic Preservation</p> <p><input checked="" type="checkbox"/> Not in District or Landmark</p> <p><input type="checkbox"/> Does Not Require Review</p> <p><input type="checkbox"/> Requires Review</p> <p><input type="checkbox"/> Approved</p> <p><input type="checkbox"/> Approved w/Conditions</p> <p><input type="checkbox"/> Denied</p> <p>Date: _____</p>
---	---	---	--

CERTIFICATION

I hereby certify that I am the owner of record of the named property, or that the proposed work is authorized by the owner of record and that I have been authorized by the owner to make this application as his authorized agent and I agree to conform to all applicable laws of this jurisdiction. In addition, if a permit for work described in the application is issued, I certify that the code official's authorized representative shall have the authority to enter all areas covered by such permit at any reasonable hour to enforce the provision of the code(s) applicable to such permit.

SIGNATURE OF APPLICANT _____ ADDRESS _____ DATE _____ PHONE _____

RESPONSIBLE PERSON IN CHARGE OF WORK, TITLE _____ DATE _____ PHONE _____

ELECTRICAL PERMIT

City of Portland, Me.



To the Chief Electrical Inspector, Portland Maine:
 The undersigned hereby applies for a permit to make electrical installations
 in accordance with the laws of Maine, the City of Portland Electrical Ordinance,
 National Electrical Code and the following specifications:

Date 9/26/05
 Permit # 054895
 CBL# B3 EA 31

LOCATION: LOT 31 SPRING LOVE LANE METER MAKE & # _____
 CMP ACCOUNT # _____ OWNER RYAN RICOBY
 TENANT _____ PHONE # _____

							TOTAL EACH FEE			
OUTLETS	32	Receptacles	12	Switches	6	Smoke Detector	50	.20	10.00	
FIXTURES	9	Incandescent	2	Fluorescent		Strips	4	.20	2.20	
SERVICES		Overhead		Underground	X	TTL AMPS 700 <800		15.00	15.00	
		Overhead		Underground		>800		25.00		
Temporary Service		Overhead		Underground		TTL AMPS		25.00		
								25.00		
METERS	✓	(number of)	1					1.00	1.00	
MOTORS		(number of)						2.00		
RESID/COM		Electric units						1.00		
HEATING		oil/gas units		Interior		Exterior		5.00		
APPLIANCES	1	Ranges		Cook Tops		Wall Ovens		2.00	2.00	
		Insta-Hot		Water heaters		Fans		2.00		
	1	Dryers		Disposals	1	Dishwasher		2.00	4.00	
		Compactors		Spa	1	Washing Machine		2.00	2.00	
MISC. (number of)		Others (denote)						2.00		
		Air Cond/win						3.00		
		Air Cond/cent					Pools	10.00		
		HVAC		EMS			Thermostat	5.00		
		Signs						10.00		
		Alarms/res						5.00		
		Alarms/com						25.00		
		Heavy Duty(CRKT)						2.00		
		Circus/Carnv						25.00		
		Alterations						5.00		
		Fire Repairs						15.00		
		E Lights						1.00		
	E Generators						20.00			
PANELS		Service		Remote		Main		4.00		
		0-25 Kva						5.00		
		25-200 Kva						8.00		
TRANSFORMER		Over 200 Kva					10.00			
TOTAL AMOUNT DUE									36.20	
MINIMUM FEE/COMMERCIAL 45.00										
MINIMUM FEE							35.00			

DEPT. OF BUILDING INSPECTION
 CITY OF PORTLAND, ME
 SEP 26 2005
 RECEIVED

CONTRACTORS NAME SEACOAST ELECTRIC CO MASTER LIC. # MJ03088
 ADDRESS 74 GREENWOOD LANE LIMITED LIC. # _____
 TELEPHONE 232-9159

SIGNATURE OF CONTRACTOR [Signature] ✓ 7215 +1.00 #COP

PLUMBING APPLICATION

Town or Plantation: Great Diamond Island
 Street Subdivision Lot #: Lot # 31
 Last: Rickaby First: Ryan
 Applicant Name: Norman Rickaby
 Mailing Address of Owner/Applicant (if Different): 69 Beach Ave, Long Beach, ME

PORTLAND PERMIT # 9666 TOWN COPY
 Date Permit Issued: 1/21/85 \$ 111.00 FEE Double Fee Charged
Tome Mackley L.P.L. # 02149
 Local Plumbing Inspector Signature

Owner/Applicant Statement
 I certify that the information submitted is correct to the best of my knowledge and understand that any falsification is reason for the Local Plumbing Inspectors to deny a Permit.
[Signature] Date: 1/21/85
 Signature of Owner/Applicant

Caution: Inspection Required
 I have inspected the installation authorized above and found it to be in compliance with the Maine Plumbing Rules.
[Signature] Date Approved: _____
 Local Plumbing Inspector Signature

This Application Is for

1. NEW PLUMBING
 2. RELOCATED PLUMBING

Type of Structure To Be Served:

1. SINGLE FAMILY DWELLING
 2. MODULAR OR MOBILE HOME
 3. MULTIPLE FAMILY DWELLING
 4. OTHER - SPECIFY _____

Plumbing To Be Installed By:

1. MASTER PLUMBER
 2. OIL BURNERMAN
 3. MFG'D. HOUSING DEALER/MECHANIC
 4. PUBLIC UTILITY EMPLOYEE
 5. PROPERTY OWNER
 LICENSE # M 89.00/08367

Hook-Up & Piping Relocation Maximum of 1 Hook-Up:	Column 2 Type of Fixture		Column 1 Type of Fixture	
	Number	Type of Fixture	Number	Type of Fixture
<p>OR</p> <p>HOOK-UP: to public sewer in those cases where the connection is not regulated and inspected by the local Sanitary District.</p> <p>HOOK-UP: to an existing subsurface wastewater disposal system.</p> <p>PIPING RELOCATION: of sanitary lines, drains, and piping without new fixtures.</p> <p>OR</p> <p>TRANSFER FEE [\$6.00]</p>	1	Hosebibb / Silcock	1	Bathtub (and Shower)
		Floor Drain	1	Shower (Separate)
		Urinal	1	Sink
		Drinking Fountain	3	Wash Basin
		Indirect Waste	3	Water Closet (Toilet)
		Water Treatment Softener, Filter, etc.	1	Clothes Washer
		Grease / Oil Separator		Dish Washer
		Roof Drain		Garbage Disposal
		Bidet		Laundry Tub
		Other: _____	1	Water Heater
	Fixtures (Subtotal) Column 2		11	

SEE PERMIT FEE SCHEDULE FOR CALCULATING FEE
35.00 78.00
1/88

City of Portland, Maine - Building or Use Permit

389 Congress Street, 04101 Tel: (207) 874-8703, Fax: (207) 874-8716

Permit No: 05-0947	Date Applied For: 07/11/2005	CBL: 083E A031001
-----------------------	---------------------------------	----------------------

Location of Construction: 29 Spring Cove Ln	Owner Name: Rickarby Ryan &	Owner Address: 3 Country Farm Rd	Phone: 603-772-4446
Business Name:	Contractor Name: TBD	Contractor Address: Portland	Phone:
Lessee/Buyer's Name	Phone:	Permit Type: Single Family	

Proposed Use: Summer cottage 3 bedrooms & 2/12 Baths	Proposed Project Description: Summer cottage 3 bedrooms & 2/12 Baths
---	---

Dept: Zoning Status: Approved with Conditions Reviewer: Marge Schmuckal Approval Date: 08/08/2005

Note: Ok to Issue:

- 1) This property shall remain a single family dwelling. Any change of use shall require a separate permit application for review and approval.
- 2) This permit is being approved on the basis of plans submitted. Any deviations shall require a separate approval before starting that work.
- 3) Separate permits shall be required for future decks, sheds, pools, and/or garages.

Dept: Building Status: Approved with Conditions Reviewer: Tammy Munson Approval Date: 08/31/2005

Note: Ok to Issue:

- 1) Separate permits are required for any electrical, plumbing, or heating.
- 2) As discussed, the first floor system will be insulated in order to comply with the energy efficiency code.
- 3) The basement is NOT approved as habitable space.
- 4) The outdoor shower is NOT approved as part of this permit.
- 5) As discussed, a graspable handrail shall be placed on each run of stairs within the structure and shall return to the wall at the beginning and end of the run.
- 6) Permit approved based on the plans submitted and reviewed w/owner/contractor, with additional information as agreed on and as noted on plans.

Dept: DRC Status: Approved with Conditions Reviewer: Jay Reynolds Approval Date: 08/02/2005

Note: Ok to Issue:

- 1) All Site work (final grading, landscaping, loam and seed) must be completed prior to issuance of a certificate of occupancy.
- 2) The Development Review Coordinator reserves the right to require additional lot grading or other drainage improvements as necessary due to field conditions.
- 3) All Site Work will conform to the City of Portland ordinance on Shoreland Regulations (Division 26).

Dept: Planning Status: Not Applicable Reviewer: Jay Reynolds Approval Date: 08/02/2005

Note: Ok to Issue:

Comments:

8/16/05-gg: received revised & approved site plan. /gg

8/23/05-trmm: left message for owner for building issues

**CITY OF PORTLAND, MAINE
DEVELOPMENT REVIEW APPLICATION
PLANNING DEPARTMENT PROCESSING FORM**

Zoning Copy

2005-0155

Application I. D. Number

7/11/2005

Application Date

Rickarby Ryan &

Applicant

3 Country Farm Rd , Stratham , NH 03885

Applicant's Mailing Address

Jessica Harrison

Project Name/Description

Consultant/Agent

Agent Ph:

Agent Fax:

Applicant or Agent Daytime Telephone, Fax

29 - 29 Spring Cove Ln, Portland, Maine

Address of Proposed Site

083E A031001

Assessor's Reference: Chart-Block-Lot

Proposed Development (check all that apply): New Building Building Addition Change Of Use Residential Office Retail
 Manufacturing Warehouse/Distribution Parking Lot Other (specify) _____

1536 sq ft

40743

Proposed Building square Feet or # of Units

Acreeage of Site

Zoning

Check Review Required:

- | | | | |
|--|---|--|--|
| <input checked="" type="checkbox"/> Site Plan
(major/minor) | <input type="checkbox"/> Subdivision
of lots _____ | <input type="checkbox"/> PAD Review | <input type="checkbox"/> 14-403 Streets Review |
| <input type="checkbox"/> Flood Hazard | <input type="checkbox"/> Shoreland | <input type="checkbox"/> Historic Preservation | <input type="checkbox"/> DEP Local Certification |
| <input type="checkbox"/> Zoning Conditional
Use (ZBA/PB) | <input type="checkbox"/> Zoning Variance | <input type="checkbox"/> Other _____ | |

Fees Paid: Site Pla \$50.00 Subdivision _____ Engineer Review \$250.00 Date 7/13/2005

Zoning Approval Status:

Reviewer _____

- Approved Approved w/Conditions
See Attached Denied

Approval Date _____ Approval Expiration _____ Extension to _____ Additional Sheets
Attached

Condition Compliance _____
signature _____ date _____

Performance Guarantee Required* Not Required

* No building permit may be issued until a performance guarantee has been submitted as indicated below

- | | | | |
|---|----------------|--|-----------------|
| <input type="checkbox"/> Performance Guarantee Accepted | _____ | _____ | _____ |
| | date | amount | expiration date |
| <input type="checkbox"/> Inspection Fee Paid | _____ | _____ | |
| | date | amount | |
| <input type="checkbox"/> Building Permit Issue | _____ | | |
| | date | | |
| <input type="checkbox"/> Performance Guarantee Reduced | _____ | _____ | _____ |
| | date | remaining balance | signature |
| <input type="checkbox"/> Temporary Certificate of Occupancy | _____ | <input type="checkbox"/> Conditions (See Attached) | _____ |
| | date | | expiration date |
| <input type="checkbox"/> Final Inspection | _____ | _____ | |
| | date | signature | |
| <input type="checkbox"/> Certificate Of Occupancy | _____ | | |
| | date | | |
| <input type="checkbox"/> Performance Guarantee Released | _____ | _____ | |
| | date | signature | |
| <input type="checkbox"/> Defect Guarantee Submitted | _____ | _____ | _____ |
| | submitted date | amount | expiration date |
| <input type="checkbox"/> Defect Guarantee Released | _____ | _____ | |
| | date | signature | |



Residential Building Permit Application

If you or the property owner owes real estate or personal property taxes or user charges on any property within the City, payment arrangements must be made before permits of any kind are accepted.

Location/Address of Construction: <i>Lot #31 Spring Cove Lane, Great Diamond Island</i>		
Total Square Footage of Proposed Structure <i>1,536 sq. ft.</i>	Square Footage of Lot <i>40,743 sq. ft.</i>	
Tax Assessor's Chart, Block & Lot Chart# <i>83E</i> Block# <i>A</i> Lot# <i>31</i>	Owner: <i>Ryan & Cathleen Rickart</i>	Telephone: <i>603-772-4446</i>
Lessee/Buyer's Name (If Applicable) <i>N/A</i>	Applicant name, address & telephone: <i>SAME</i> <i>3 Country Farm Rd</i> <i>Stratham NH 03885</i>	Cost Of Work: \$ <i>250,000</i> Fee: \$ <i>2,271.00</i>
Current Specific use: <i>LAND</i>	<i>2,271</i>	
Proposed Specific use: <i>Residential (single family dwelling)</i>	<i>+ 75</i>	
Project description: <i>Summer cottage - 3 bedrooms 2 1/2 bath</i>	<i>+ 300</i>	
Contractor's name, address & telephone:		
Who should we contact when the permit is ready: <i>Ryan & Cathleen Rickart</i>		
Mailing address: <i>3 Country Farm Rd</i> <i>Stratham, NH 03885</i>		
Phone: <i>603-772-4446</i>		

DEPT. OF BUILDING INSPECTION
CITY OF PORTLAND, ME

JUL 11 2005

RECEIVED

Please submit all of the information outlined in the Residential Application Checklist. Failure to do so will result in the automatic denial of your permit.

At the discretion of the Planning and Development Department, additional information may be required prior to permit approval. For further information stop by the Building Inspections office, room 315 City Hall or call 874-8703.

I hereby certify that I am the Owner of record of the named property, or that the owner of record authorizes the proposed work and that I have been authorized by the owner to make this application as his/her authorized agent. I agree to conform to all applicable laws of this jurisdiction. In addition, if a permit for work described in this application is issued, I certify that the Code Official's authorized representative shall have the authority to enter all areas covered by this permit at any reasonable hour to enforce the provisions of the codes applicable to this permit.

Signature of applicant: <i>[Signature]</i>	Date:
--	-------

Permit Fee: \$30.00 for the first \$1000.00 Construction Cost, \$9.00 per additional \$1000.00 cost

This is not a Permit; you may not commence any work until the Permit is issued.



Residential Building Permit Application Checklist

*Will
Send PDF*

All of the following information is required and must be submitted in order to help insure an expeditious permitting process.

A complete set of construction drawings must include:

- Cross sections w/framing details
- Detail of any new walls or permanent partitions
- Floor Plans & Elevations
- Window and door schedules
- Foundation plans with required drainage and damp proofing (if applicable)
- Electrical and plumbing layout. Mechanical drawings for any specialized equipment such as furnaces, chimneys, gas equipment, HVAC equipment (air handling) or other types of work that may require special review must be included.

Separate permits are required for internal & external plumbing, HVAC, and electrical installations.

4 copies site plan & electronic PDF of 11x17 of site & constr. plans

If there are any additions to the footprint or volume of the new or existing structure(s), a plot plan is required and must include:

- The shape and dimension of the lot, footprint of the proposed structure and the distance from the actual property lines drawn to scale. Structures include decks porches; a bow windows cantilever sections and roof overhangs, sheds, pools, garages and any other accessory structures must be shown.
- Boundary survey to scale showing north arrow; zoning district and setbacks
- First floor sill elevation (based on mean sea level datum)
- Location and dimensions of parking areas and driveways
- Location and size of both existing utilities in the street and the proposed utilities serving the building
- Location of areas on the site that will be used to dispose of surface water
- Existing and proposed grade contours
- Silt fence locations

Surveyor's monuments must be in place and the lot staked for a setback inspection.

Please submit all of the information outlined in this Residential Application Checklist. Failure to do so will result in the automatic denial of your permit.

At the discretion of the Planning and Development Department, additional information may be required prior to permit approval. For further information stop by the Building Inspections office, room 315 City Hall or call 874-8703.

Permit Fee: \$30.00 for the first \$1000.00 Construction Cost, \$9.00 per additional \$1000.00 cost

This is not a Permit; you may not commence any work until the Permit is issued.

Applicant: Ryan Ruckanby

Date: 2/4/05

Address: 29 Spring Cove Ln.

C-B-L: 083E-A-03/

CHECK-LIST AGAINST ZONING ORDINANCE

Date - New Development

permit #05-0947

Zone Location - IR-1

Interior or corner lot - end of Spring Cove Ln

Proposed Use/Work - to construct new Single Family Dwelling with screened porch 16'x16'

Sevage Disposal - Private

Lot Street Frontage - 100' min - 100' + shown

Front Yard - 30' min - 34' scaled (33' shown on close-up)

Rear Yard - 30' min - 85' scaled

Side Yard - 20' min - 44' & 187' shown

Projections - front screened porch 16x16 - rear bulkhead 5x8

Width of Lot - 100' min - 100' + shown

Height - 35' MAX - 28' scaled - 14' to original grade

Lot Area - 40,000 sq ft has water 40,743 sq ft

Lot Coverage/ Impervious Surface -

20% MAX

8,148.6 sq ft

24x32 = 768
16x16 = 256
5x8 = 40
1064

Area per Family - 40,000 sq ft

Off-street Parking - 2 req - 2 parking spaces shown on side yard

Loading Bays - N/A

Site Plan - mm or mm of #2005-0155

Shoreland Zoning/ Stream Protection -

Bldg is over 60' from HWM

Flood Plains - Panel 9 - Zone C

~~20' from HWM~~
Bldg is over 500' from HWM

Showing about 2' of fill on plans

Ryan - 603-772-4446

ONE AND TWO FAMILY	PLAN REVIEW	CHECKLIST
Soil type/Presumptive Load Value (Table R401.4.1)		
STRUCTURAL Footing Dimensions/Depth (Table R403.1 & R403.1(1), (Section R403.1 & R403.1.4.1)	Not shown	OK 8" wall 16" x 8" footing
Foundation Drainage, Fabric, Damp proofing (Section R405 & R406)	OK	
Ventilation/Access (Section R408.1 & R408.3) Crawls Space ONLY	N/A	
Anchor Bolts/Straps, spacing (Section R403.1.6)	Not shown 1/2" - 6' OC	
Lally Column Type (Section R407)		
Girder & Header Spans (Table R 502.5(2))		
Built-Up Wood Center Girder Dimension/Type	Shows - 3-2x12'S - LVL'S ? or wood ?	
Sill/Band Joist Type & Dimensions	2x8 PT SILL	
First Floor Joist Species Dimensions and Spacing (Table R502.3.1(1) & Table R502.3.1(2))	2x8 Blocking under posts - NOT solid bearing	- OK bearing on bearing LVL'S
Second Floor Joist Species Dimensions and Spacing (Table R502.3.1(1) & Table R502.3.1(2))	2x8'S	
Attic or additional Floor Joist Species Dimensions and Spacing (Table R802.4(1) and	N/A	

R802.4(2))		
② Pitch, Span, Spacing & Dimension (Table R802.5.1(1) - R 802.5.1(8)) Roof Rafter; Framing & Connections (Section R802.3 & R802.3.1)	Need better labeled details OK 2x6's 16" OC	
④ Sheathing; Floor, Wall and roof (Table R503.2.1.1(1))	Walls - not noted floor - 3/4 T + G Walls - 5/8"	
⑤ Fastener Schedule (Table R602.3(1) & (2))	not noted	
Private Garage (Section R309) Living Space? (Above or beside)	N/A	
Fire separation (Section R309.2)		
Opening Protection (Section R309.1)	N/A	
Emergency Escape and Rescue Openings (Section R310)	noted on first floor plan	
Roof Covering (Chapter 9)		
⑥ Safety Glazing (Section R308)	OK - noted on 1st floor plan - Need in Stairwell	
Attic Access (Section R807)	N/A	
⑦ Chimney Clearances/Fire Blocking (Chap. 10)	0" clearance	
⑧ Header Schedule (Section 502.5(1) & (2))	not shown -	3- 2x8's
Energy Efficiency (N1101.2.1) R-Factors of Walls, Floors, Ceilings, Building Envelope, U-		

Wall - R-19
Roof - R-30
Floor - R-19

Foundation - R-10

Factor Fenestration		
① Type of Heating System	NOT shown	
Means of Egress (Sec R311 & R312)		
Basement 2		
Number of Stairways 3		
Interior 1		
Exterior 2		
② Treads and Risers (Section R311.5.3)	Inter shows - 10" T 7 3/4" R - no other stairs labeled	
Width (Section R311.5.1)	3-6 - OK	
③ Headroom (Section R311.5.2)	not shown	
④ Guardrails and Handrails (Section R312 & R311.5.6 - R311.5.6.3)	not shown — need handrail on stairs	
⑤ Smoke Detectors (Section R313)		
Location and type/Interconnected	not shown	
Dwelling Unit Separation (Section R317) and IBC - 2003 (Section 1207)	N/A	
⑥ Deck Construction (Section R502.2.1)	not shown - OK	

⑦ No outdoor shower

SUBSURFACE WASTEWATER DISPOSAL SYSTEM APPLICATION

Division of Health Engineering, 10 SHS
(207) 287-5872 Fax: (207) 287-3165

PROPERTY LOCATION		>> CAUTION: PERMIT REQUIRED - ATTACH IN SPACE BELOW <<	
City, Town, or Plantation	PORTLAND / DIAMOND COVE	2008-0015 PORTLAND PERMIT # 9565 TOWN COPY Date Permit Issued: 19 23 05 \$ 111.00 FEE Double Fee Charged L.P.I. # 02144 [Signature] Local Plumbing Inspector Signature	
Street or Road	SPRING COVE LANE		
Subdivision, Lot #	LOT No. 31		
OWNER/APPLICANT INFORMATION			
Name (last, first, MI)	RICKERBYE, RYAN <input checked="" type="checkbox"/> Owner <input type="checkbox"/> Applicant		
Mailing Address of Owner/Applicant	3 COUNTRY FARM RD. STRATHAM, N.H. 03885	83 EA 31	
Daytime Tel. #	1-603-772-4446	Municipal Tax Map # 83E-A Lot # 31	

OWNER OR APPLICANT STATEMENT I state and acknowledge that the information submitted is correct to the best of my knowledge and understand that any falsification is reason for the Department and/or Local Plumbing Inspector to deny a Permit.	CAUTION: INSPECTION REQUIRED I have inspected the installation authorized above and found it to be in compliance with the Subsurface Wastewater Disposal Rules Application.
[Signature] Signature of Owner or Applicant Date: 7.7.05	[Signature] Local Plumbing Inspector Signature (1st) date approved

PERMIT INFORMATION		
TYPE OF APPLICATION	THIS APPLICATION REQUIRES	DISPOSAL SYSTEM COMPONENTS
<input checked="" type="checkbox"/> 1. First Time System <input type="checkbox"/> 2. Replacement System Type replaced: _____ Year installed: _____ <input type="checkbox"/> 3. Expanded System <input type="checkbox"/> a. Minor Expansion <input type="checkbox"/> b. Major Expansion <input type="checkbox"/> 4. Experimental System <input type="checkbox"/> 5. Seasonal Conversion	<input checked="" type="checkbox"/> 1. No Rule Variance <input type="checkbox"/> 2. First Time System Variance <input type="checkbox"/> a. Local Plumbing Inspector Approval <input type="checkbox"/> b. State & Local Plumbing Inspector Approval <input type="checkbox"/> 3. Replacement System Variance <input type="checkbox"/> a. Local Plumbing Inspector Approval <input type="checkbox"/> b. State & Local Plumbing Inspector Approval <input type="checkbox"/> 4. Minimum Lot Size Variance <input type="checkbox"/> 5. Seasonal Conversion Permit	<input checked="" type="checkbox"/> 1. Complete Non-engineered System <input type="checkbox"/> 2. Primitive System (graywater & alt. toilet) <input type="checkbox"/> 3. Alternative Toilet, specify: _____ <input type="checkbox"/> 4. Non-engineered Disposal Area <input type="checkbox"/> 5. Holding Tank, _____ gallons <input type="checkbox"/> 6. Non-engineered Disposal Field (only) <input type="checkbox"/> 7. Separated Laundry System <input type="checkbox"/> 8. Complete Engineered System (2000 gpd or more) <input type="checkbox"/> 9. Engineered Treatment Tank (only) <input type="checkbox"/> 10. Engineered Disposal Field (only) <input type="checkbox"/> 11. Pre-treatment, specify: _____ <input type="checkbox"/> 12. Miscellaneous Components
SIZE OF PROPERTY 40,743 <input checked="" type="checkbox"/> SQ. FT. <input type="checkbox"/> ACRES	DISPOSAL SYSTEM TO SERVE <input checked="" type="checkbox"/> 1. Single Family Dwelling Unit, No. of Bedrooms: 3 <input type="checkbox"/> 2. Multiple Family Dwelling, No. of Units: _____ <input type="checkbox"/> 3. Other: _____ (specify) Current Use <input type="checkbox"/> Seasonal <input type="checkbox"/> Year Round <input checked="" type="checkbox"/> Undeveloped	TYPE OF WATER SUPPLY <input type="checkbox"/> 1. Drilled Well <input type="checkbox"/> 2. Dug Well <input type="checkbox"/> 3. Private <input checked="" type="checkbox"/> 4. Public <input type="checkbox"/> 5. Other
SHORELAND ZONING <input checked="" type="checkbox"/> Yes <input type="checkbox"/> No		

DESIGN DETAILS (SYSTEM LAYOUT SHOWN ON PAGE 3)			
TREATMENT TANK <input checked="" type="checkbox"/> 1. Concrete <input type="checkbox"/> a. Regular <input type="checkbox"/> b. Low Profile <input type="checkbox"/> 2. Plastic <input type="checkbox"/> 3. Other: _____ CAPACITY: 1000 GAL.	DISPOSAL FIELD TYPE & SIZE <input type="checkbox"/> 1. Stone Bed <input type="checkbox"/> 2. Stone Trench <input checked="" type="checkbox"/> 3. Proprietary Device <input type="checkbox"/> a. cluster array <input checked="" type="checkbox"/> c. Linear <input type="checkbox"/> b. regular load <input type="checkbox"/> d. H-20 load <input type="checkbox"/> 4. Other: _____ SIZE: 900 <input type="checkbox"/> sq. ft. <input type="checkbox"/> lin. ft.	GARBAGE DISPOSAL UNIT <input checked="" type="checkbox"/> 1. No <input type="checkbox"/> 2. Yes <input type="checkbox"/> 3. Maybe If Yes or Maybe, specify one below: <input type="checkbox"/> a. multi-compartment tank <input type="checkbox"/> b. _____ tanks in series <input type="checkbox"/> c. increase in tank capacity <input type="checkbox"/> d. Filter on Tank Outlet	DESIGN FLOW 270 gallons per day BASED ON: <input checked="" type="checkbox"/> 1. Table 501.1 (dwelling unit(s)) <input type="checkbox"/> 2. Table 501.2 (other facilities) SHOW CALCULATIONS — for other facilities —
SOIL DATA & DESIGN CLASS PROFILE CONDITION DESIGN: 2, AIII/C1 at Observation Hole # 56 Depth 22' of Most Limiting Soil Factor: BEDROCK	DISPOSAL FIELD SIZING <input type="checkbox"/> 1. Small—2.0 sq. ft. / gpd <input type="checkbox"/> 2. Medium—2.6 sq. ft. / gpd <input checked="" type="checkbox"/> 3. Medium—Large 3.3 sq. ft. / gpd <input type="checkbox"/> 4. Large—4.1 sq. ft. / gpd <input type="checkbox"/> 5. Extra Large—5.0 sq. ft. / gpd	EFFLUENT/EJECTOR PUMP <input type="checkbox"/> 1. Not Required <input type="checkbox"/> 2. May Be Required <input checked="" type="checkbox"/> 3. Required Specify only for engineered systems: DOSE: _____ gallons	

SITE EVALUATOR STATEMENT		
certify that on 4/15/05 (date) I completed a site evaluation on this property and state that the data reported are accurate and that the proposed system is in compliance with the State of Maine Subsurface Wastewater Disposal Rules (10-144A CMR 241).		
[Signature] Site Evaluator Signature	185 SE #	4/15/05 Date

DAVID A. KAMILA
Site Evaluator Name Printed

Note: Changes to or deviations from the design should be confirmed with the Site Evaluator.

Page 1 of 3
HHE-200 Rev. 8/01

SUBSURFACE WASTEWATER DISPOSAL SYSTEM APPLICATION

maine Department of Human Services
 Division of Health Engineering, Station 10
 (207) 287-5872 FAX (207) 287-4172

Town, City, Plantation: **PORTLAND / DIAMOND COVE** Street, Road, Subdivision: **SPRING COVE LANE** Owner or Applicant Name: **RYAN RICKERBIG**

SITE PLAN

Scale: 1" = 100 Ft.
 or as shown

SITE LOCATION PLAN

(Map from The Maine Atlas recommended)

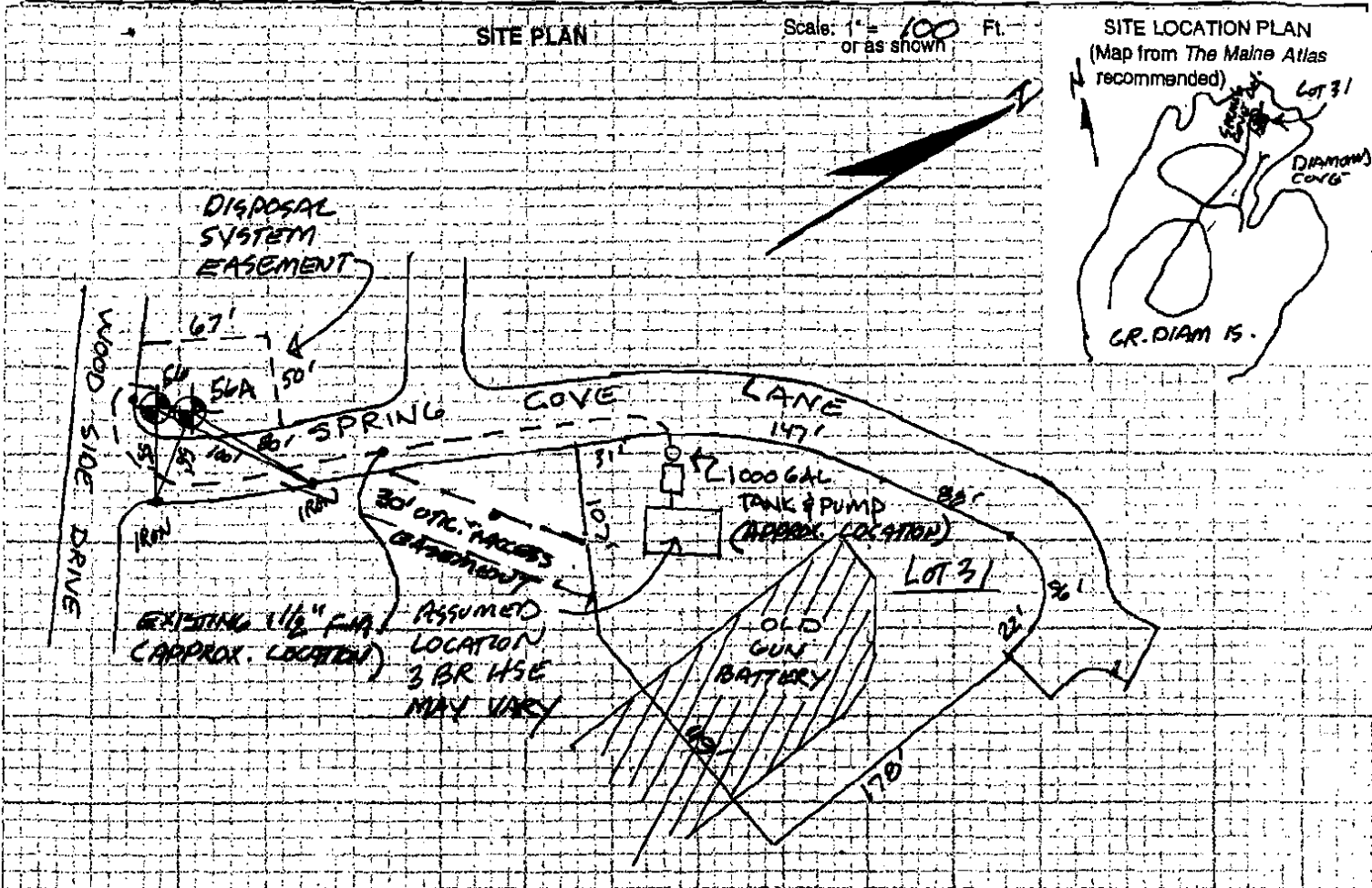
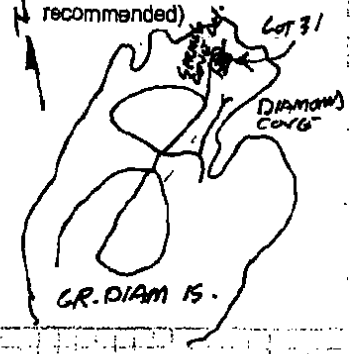

SOIL DESCRIPTION AND CLASSIFICATION

(Location of Observation Holes Shown Above)

Observation Hole 56a Test Pit Boring
 2" Depth of Organic Horizon Above Mineral Soil

Depth (inches)	Texture	Consistency	Color	Mottling
0-6			DARK BROWN	
6-10	FINE	FRAGILE		
10-15	SANDY	LOOSE	REDDISH	NONE
15-20	LOAM		BROWN	
20-30	X X X X X X X X			
30-40	BEDROCK			
40-50				
50-60				

Soil Profile	Class	Slope	Limiting Factor	<input type="checkbox"/> Ground Water
2	AUIC	7%	22	<input type="checkbox"/> Restrictive Layer
				<input checked="" type="checkbox"/> Bedrock

Observation Hole 56A Test Pit Boring
 2" Depth of Organic Horizon Above Mineral Soil

Depth (inches)	Texture	Consistency	Color	Mottling
0-6			DARK BROWN	
6-10	FINE	FRAGILE		
10-15	SANDY		BROWN	
15-20	LOAM	LOOSE		
20-30				
30-40				COMM. DIST.
40-50	X X X X X X X X			
50-60	BEDROCK			
60-70				

Soil Profile	Class	Slope	Limiting Factor	<input checked="" type="checkbox"/> Ground Water
2	AUIC	7%	20	<input type="checkbox"/> Restrictive Layer
				<input type="checkbox"/> Bedrock

David A. Kainle
 Site Evaluator Signature

185
 SE #

4/15/05*
 Date

*ORIG. TEST PITS EVALUATED 10/17/84 CONFIRMED 4/15/05

SUBSURFACE WASTEWATER DISPOSAL SYSTEM APPLICATION

Maine Department of Human Services
 Division of Health Engineering, Station 10
 (207) 287-5872 FAX (207) 287-4172

Town, City, Plantation: **PORTLAND / DIAMOND COVE** Street, Road, Subdivision: **SPRING COVE LANE / LOT 31** Owner or Applicant Name: **RYAN RICKER BIE**

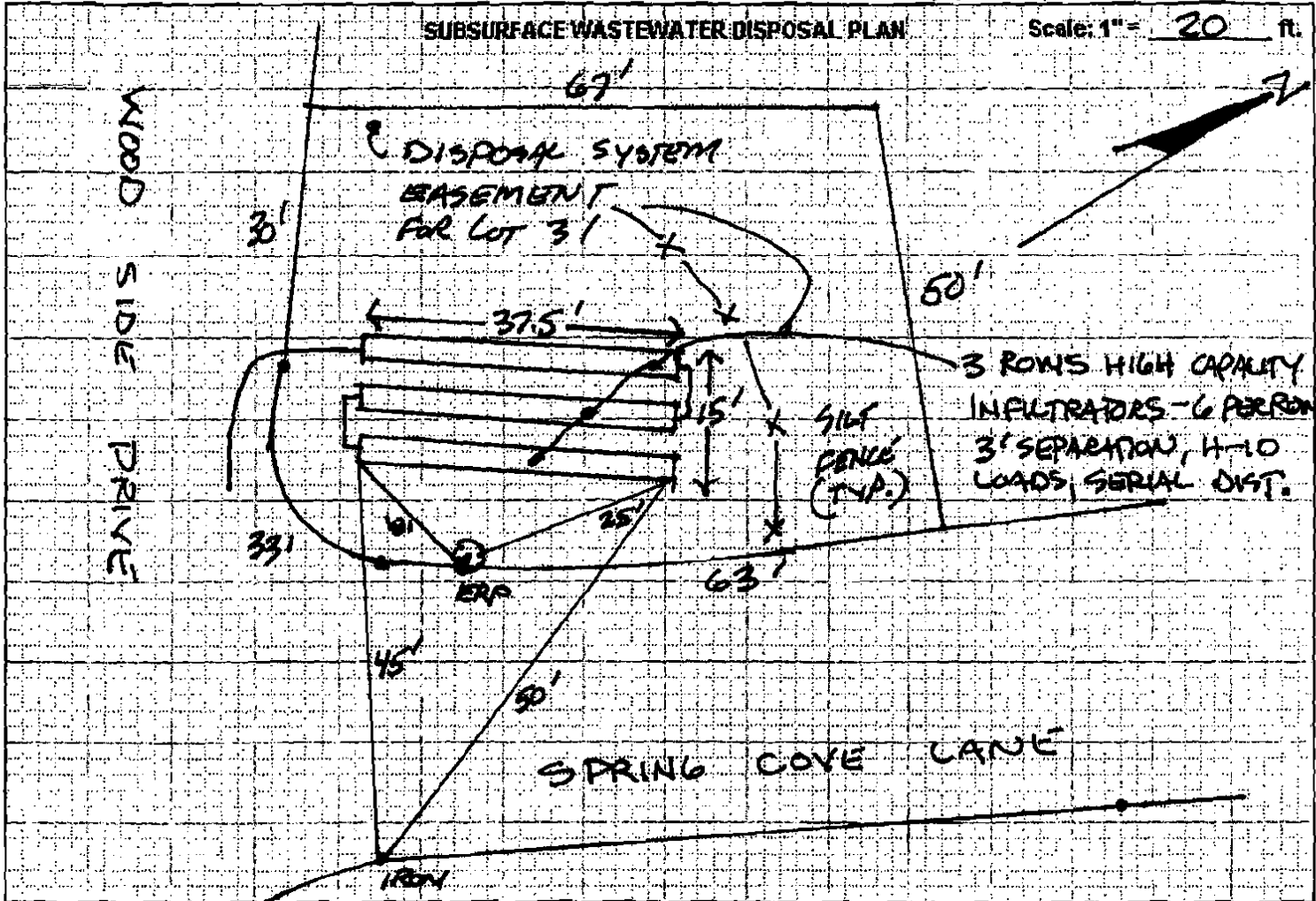

BACKFILL REQUIREMENTS		CONSTRUCTION ELEVATIONS		ELEVATION REFERENCE POINT	
Depth of Backfill (upslope)	36"	Finished Grade Elevation	58'	Location & Description:	WOOD NAIL
Depth of Backfill (downslope)	24"	Top of Distribution Pipe or Proprietary Device	57'		IN 8" BIRCH 54" ABOVE GARAGE
DEPTHS AT CROSS-SECTION (shown below)		Bottom of Disposal Field	56'0"	Reference Elevation Is: 0.0" or _____	

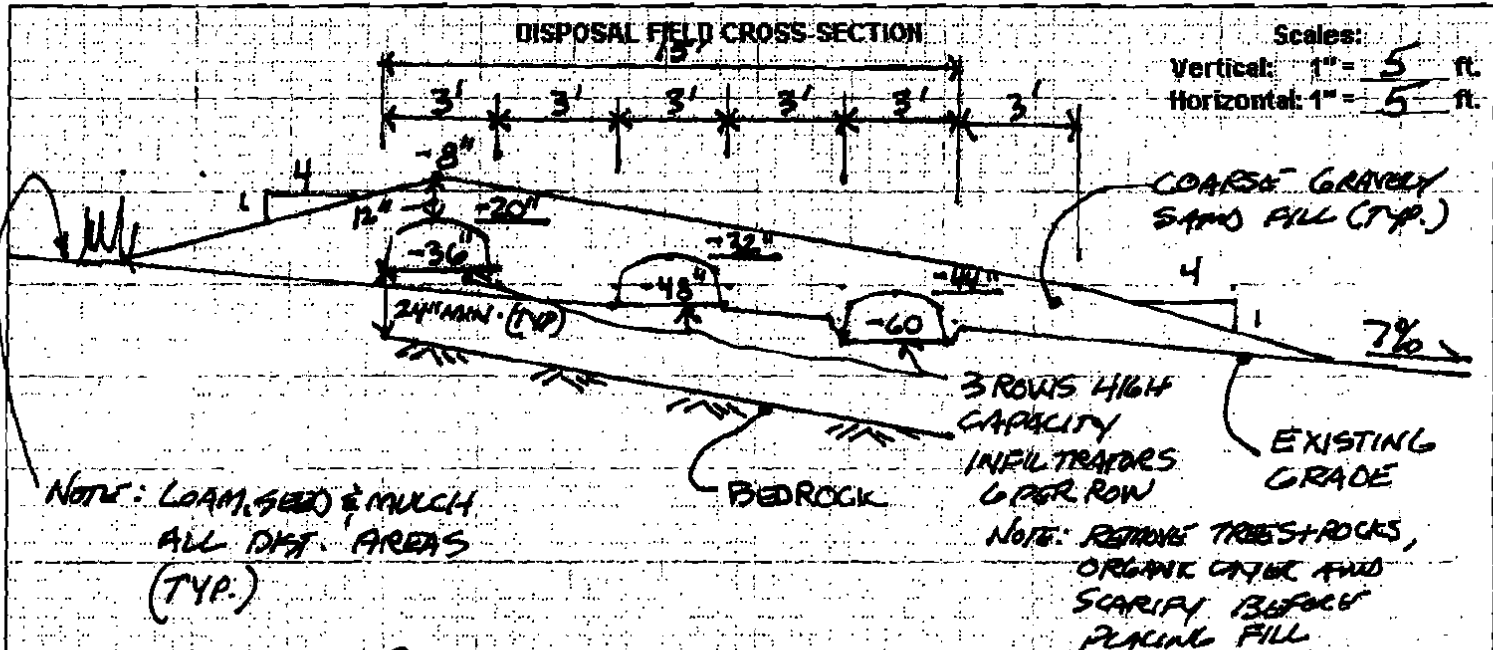

NOTE: LOAM, SEED & MULCH ALL DIST. AREAS (TYP.)

NOTE: REMOVE TREE STUMPS, ORGANIC MATTER AND SCARIFY BEFORE PLACING FILL

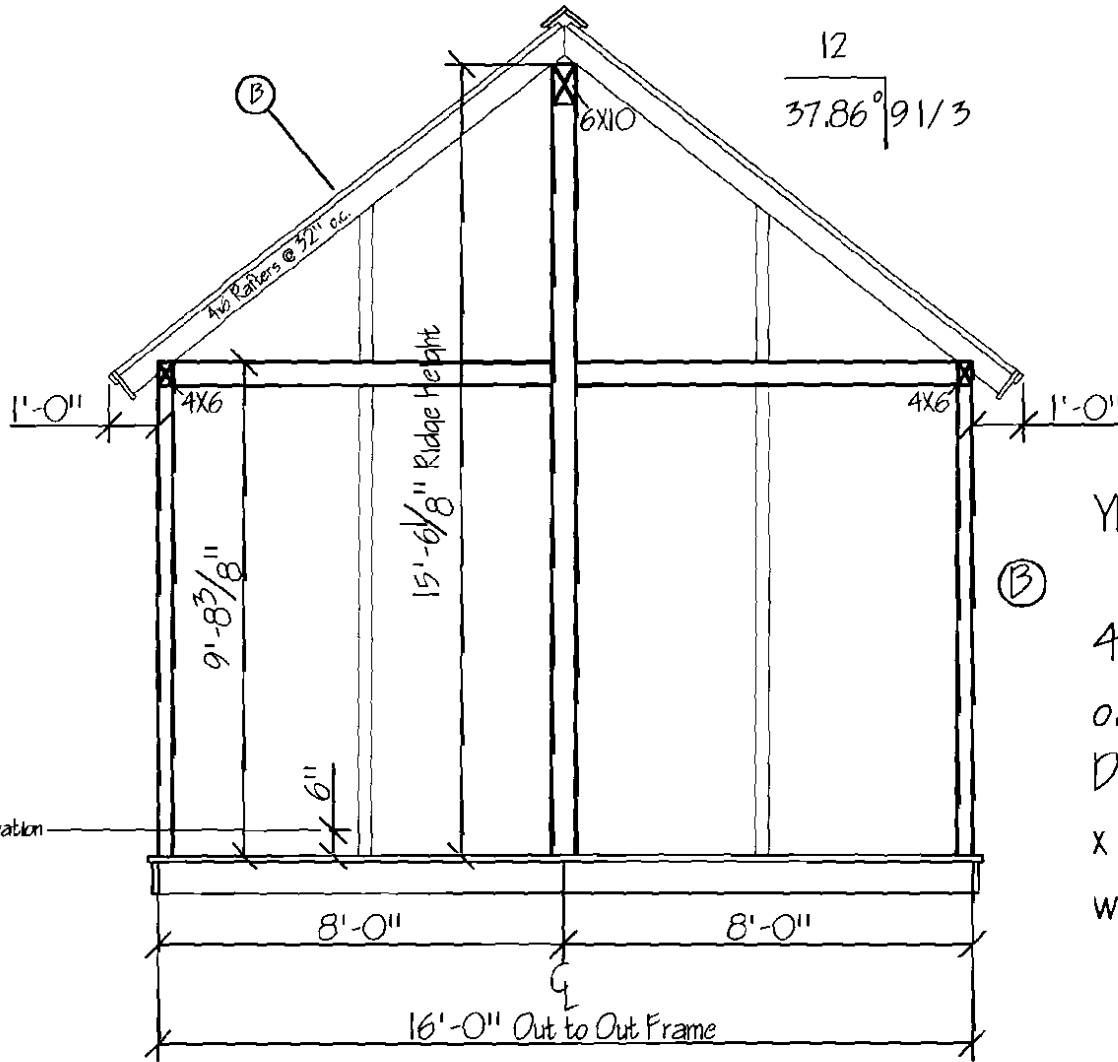

YBH Porch

ⓑ

4x6 Douglas Fir #1 Rafters @ 32" o.c. Spiked with 1/4 x 9" spikes to Douglas Fir Frame. Covered with 2" x 6" T&G Spruce Decking attached with 16d. Roof covering by builder.

Screened Porch

Section @ D-D

Yankee BARN HOMES
Woodworks Design Software

131 Yankee Barn Road
Granham, NH 03753
u: 603-863-4545
f: 603-863-4551

COMPANY

PROJECT

Aug. 30, 2005 15:23:23 Beam1

Design Check Calculation Sheet
Sizer 2002a

LOADS: (lbs, psf, or plf)

Load	Type	Distribution	Magnitude		Location [ft]		Pattern Load?
			Start	End	Start	End	
dead	Dead	Full Area	10.00	(2.67)*			No
snow	Snow	Full Area	50.00	(2.67)*			No

*Tributary Width (ft)

MAXIMUM REACTIONS (lbs) and BEARING LENGTHS (in) :

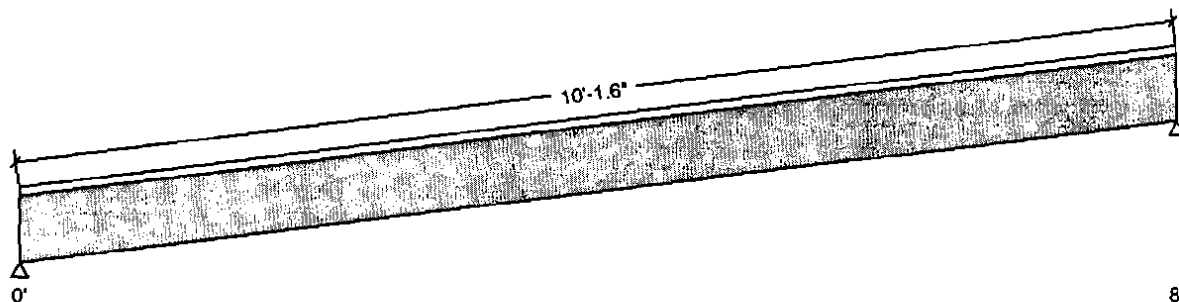

Dead	158	158
Live	533	533
Total	692	692
Bearing Length	1.0	1.0

Lumber-soft, D.Fir-L, No.1, 4x6"

Slope: 37.9 deg.; Total length: 10'-1.6". Self Weight of 4.57 plf automatically included in loads;

Lateral support: top= full, bottom= at supports; Load combinations: ICC-IBC;

SECTION vs. DESIGN CODE NDS-1997: (stress=psi, and in)

Criterion	Analysis Value	Design Value	Analysis/Design
Shear	$f_v @ d = 39$	$F_v' = 109$	$f_v/F_v' = 0.35$
Bending(+)	$f_b = 941$	$F_b' = 1495$	$f_b/F_b' = 0.63$
Live Defl'n	$0.24 = L/508$	$0.34 = L/360$	0.71
Total Defl'n	$0.35 = L/352$	$0.68 = L/180$	0.51

ADDITIONAL DATA:

FACTORS:	F	CD	CM	Ct	CL	CF	CV	Cfu	Cr	LC#
$F_b' +/-$	1000	1.15	1.00	1.00	1.000	1.30	1.000	1.00	1.00	2
F_v'	95	1.15	1.00	1.00						2
F_{cp}'	625		1.00	1.00						-
E'	1.7 million		1.00	1.00						2

Bending(+): LC# 2 = D+S, M = 1383 lbs-ft

Shear : LC# 2 = D+S, V = 546, $v@d = 496$ lbs

Deflection: LC# 2 = D+S EI= 82.49e06 lb-in²

Total Deflection = 1.50(Dead Load Deflection) + Live Load Deflection.

(D=dead L=live S=snow W=wind I=impact C=construction CLD=concentrated)

(All LC's are listed in the Analysis output)

DESIGN NOTES:

- Please verify that the default deflection limits are appropriate for your application.
- Sawn lumber bending members shall be laterally supported according to the provisions of NDS Clause 4.4.1.
- SLOPED BEAMS: level bearing is required for all sloped beams.

Permit Number
Checked By/Date



Generated by REScheck Package Generator
Compliance Certificate

Project Title: Springcove Lane

Energy Code: 1995 MEC
Location: Portland, Maine
Construction Type: Single Family
Window-to-Wall Ratio: 0.15
Heating Degree Days: 7378

Report Date:

Date of Plans:

Project Information:

Builder Information:

Project Notes:

Compliance Passes			
Assembly	Cavity R-Value	Cont. R-Value	Glazing or Door U-Factor
Ceiling:	33.0	0.0	
Wall:	25.0	0.0	
Window:			0.350
Door:			0.350
Floor:	19.0	0.0	
Furnace: : 85 AFUE			

Statement of Compliance: The proposed building design described here is consistent with the building plans, specifications, and other calculations submitted with the permit application. The proposed building has been designed to meet the 1995 MEC requirements in the REScheck Package Generator and to comply with the mandatory requirements listed in the REScheck Inspection Checklist.

Builder/Designer **Company Name** **Date**



Generated by REScheck Package Generator

REScheck Inspection Checklist

Project Title: Springcove Lane

Ceilings:

- Ceiling: , R-33.0 cavity insulation

Comments: _____

Above-Grade Walls:

- Wall: , R-25.0 cavity insulation

Comments: _____

Windows:

- Window: , U-factor: 0.350

For windows without labeled U-factors, describe features:

#Panels _____ Frame Type _____ Thermal Break? _____ Yes _____ No

Comments: _____

Doors:

- Door: , U-factor: 0.350

Comments: Front door exempt

Floors:

- Floor: , R-19.0 cavity insulation

Comments: _____

Heating and Cooling Equipment:

- Furnace: : 85 AFUE or higher

Make and Model Number: _____

Air Leakage:

- Joints, penetrations, and all other such openings in the building envelope that are sources of air leakage must be sealed.
- Recessed lights must be 1) Type IC rated, or 2) installed inside an appropriate air-tight assembly with a 0.5" clearance from combustible materials. If non-IC rated, the fixture must be installed with a 3" clearance from insulation.

Vapor Retarder:

- Required on the warm-in-winter side of all non-vented framed ceilings, walls, and floors.

Materials Identification:

- Materials and equipment must be identified so that compliance can be determined.
- Manufacturer manuals for all installed heating and cooling equipment and service water heating equipment must be provided.
- Insulation R-values, glazing U-factors, and heating equipment efficiency must be clearly marked on the building plans or specifications.

Duct Insulation:

- Ducts in unconditioned spaces must be insulated to R-5. Ducts outside the building must be insulated to R-8.0.

Duct Construction:

- All ducts must be sealed with mastic and fibrous backing tape. Pressure-sensitive tape may be used for fibrous ducts. Duct tape is not permitted.

- The HVAC system must provide a means for balancing air and water systems.

Temperature Controls:

- Thermostats are required for each separate HVAC system. A manual or automatic means to partially restrict or shut off the heating and/or cooling input to each zone or floor shall be provided.

Circulating Hot Water Systems:

- Insulate circulating hot water pipes to the levels in Table 1.

Swimming Pools:

- All heated swimming pools must have an on/off heater switch and require a cover unless over 20% of the heating energy is from non-depletable sources. Pool pumps require a time clock.

Heating and Cooling Piping Insulation:

- HVAC piping conveying fluids above 120°F or chilled fluids below 55°F must be insulated to the levels in Table 2.

Table 1: Minimum Insulation Thickness for Circulating Hot Water Pipes

Heated Water Temperature (°F)	Insulation Thickness in Inches by Pipe Sizes			
	Non-Circulating Runouts		Circulating Mains and Runouts	
	Up to 1"	Up to 1.25"	1.5" to 2.0"	Over 2"
170-180	0.5	1.0	1.5	2.0
140-160	0.5	0.5	1.0	1.5
100-130	0.5	0.5	0.5	1.0

Table 2: Minimum Insulation Thickness for HVAC Pipes, Hot Water Pipes

Piping System Types	Fluid Temp. Range(°F)	Insulation Thickness in Inches by Pipe Sizes			
		2" Runouts	1" and Less	1.25" to 2.0"	2.5" to 4"
Heating Systems					
Low Pressure/Temperature	201-250	1.0	1.5	1.5	2.0
Low Temperature	120-200	0.5	1.0	1.0	1.5
Steam Condensate (for feed water)	Any	1.0	1.0	1.5	2.0
Cooling Systems					
Chilled Water, Refrigerant and Brine	40-55	0.5	0.5	0.75	1.0
	Below 40	1.0	1.0	1.5	1.5

NOTES TO FIELD: (Building Department Use Only)

- ① FOUNDATION WALL 8"
FOOTING SIZE (2X WALL THICKNESS) 16"
FOOTING DEPTH (1X WALL THICKNESS) 8"
- ③ ROOF PANELS 2X6 @ 16" ON CENTER
SPAN BETWEEN VERTICAL POSTS 10'
POSTS ARE CONTINUOUS DOWN TO FOOTING
- ④ WALL SHEATHING SHOWN ON CROSS SECTION SHEET # 6
- ⑤A WINDOW SHOWN IN STAIRWELL TEMPERED GLASS
SHOWN ON SHEET # 1
- ⑦ SUMMER USE, VERMONT CASTINGS GAS STOVE FOR
SUPPLEMENTAL HEAT. (SPECIFICATIONS INCLUDED WITH
INITIAL APPLICATION)
- ⑧ EXTERIOR STAIR, RISE 2.0" RUN 10.0" (SHOWN ON SHEET
4)
- ⑨ HEADROOM SHOWN ON SHEET # 6 STAIR CROSSSECTION
- ⑩ SMOKE DETECTOR SHOWN ON ELECTRICAL PLAN
- ⑫ DECK CONSTRUCTION SHOWN ON SHEET # 3X

GENERAL NOTES

1. REFER TO EXISTING CONDITIONS, SURVEYS AND MATERIALS IN THE FIELD. REPORT ALL DISCREPANCIES.

2. ALL CONCRETE SHALL BE CURVED, UNLESS OTHERWISE NOTED. REINFORCE ALL CONCRETE WITH #4 BARS AT 12" ON CENTER. ALL CONCRETE SHALL BE CURED FOR 7 DAYS. ALL CONCRETE SHALL BE PROTECTED FROM DAMAGE BY ALL OPERATIONS AND EQUIPMENT. ALL CONCRETE SHALL BE PROTECTED FROM DAMAGE BY ALL OPERATIONS AND EQUIPMENT.

3. ALL CONCRETE SHALL BE PROTECTED FROM DAMAGE BY ALL OPERATIONS AND EQUIPMENT. ALL CONCRETE SHALL BE PROTECTED FROM DAMAGE BY ALL OPERATIONS AND EQUIPMENT.

4. ALL CONCRETE SHALL BE PROTECTED FROM DAMAGE BY ALL OPERATIONS AND EQUIPMENT. ALL CONCRETE SHALL BE PROTECTED FROM DAMAGE BY ALL OPERATIONS AND EQUIPMENT.

5. ALL CONCRETE SHALL BE PROTECTED FROM DAMAGE BY ALL OPERATIONS AND EQUIPMENT. ALL CONCRETE SHALL BE PROTECTED FROM DAMAGE BY ALL OPERATIONS AND EQUIPMENT.

6. ALL CONCRETE SHALL BE PROTECTED FROM DAMAGE BY ALL OPERATIONS AND EQUIPMENT. ALL CONCRETE SHALL BE PROTECTED FROM DAMAGE BY ALL OPERATIONS AND EQUIPMENT.

7. ALL CONCRETE SHALL BE PROTECTED FROM DAMAGE BY ALL OPERATIONS AND EQUIPMENT. ALL CONCRETE SHALL BE PROTECTED FROM DAMAGE BY ALL OPERATIONS AND EQUIPMENT.

8. ALL CONCRETE SHALL BE PROTECTED FROM DAMAGE BY ALL OPERATIONS AND EQUIPMENT. ALL CONCRETE SHALL BE PROTECTED FROM DAMAGE BY ALL OPERATIONS AND EQUIPMENT.

9. ALL CONCRETE SHALL BE PROTECTED FROM DAMAGE BY ALL OPERATIONS AND EQUIPMENT. ALL CONCRETE SHALL BE PROTECTED FROM DAMAGE BY ALL OPERATIONS AND EQUIPMENT.

10. ALL CONCRETE SHALL BE PROTECTED FROM DAMAGE BY ALL OPERATIONS AND EQUIPMENT. ALL CONCRETE SHALL BE PROTECTED FROM DAMAGE BY ALL OPERATIONS AND EQUIPMENT.

11. ALL CONCRETE SHALL BE PROTECTED FROM DAMAGE BY ALL OPERATIONS AND EQUIPMENT. ALL CONCRETE SHALL BE PROTECTED FROM DAMAGE BY ALL OPERATIONS AND EQUIPMENT.

12. ALL CONCRETE SHALL BE PROTECTED FROM DAMAGE BY ALL OPERATIONS AND EQUIPMENT. ALL CONCRETE SHALL BE PROTECTED FROM DAMAGE BY ALL OPERATIONS AND EQUIPMENT.

13. ALL CONCRETE SHALL BE PROTECTED FROM DAMAGE BY ALL OPERATIONS AND EQUIPMENT. ALL CONCRETE SHALL BE PROTECTED FROM DAMAGE BY ALL OPERATIONS AND EQUIPMENT.

14. ALL CONCRETE SHALL BE PROTECTED FROM DAMAGE BY ALL OPERATIONS AND EQUIPMENT. ALL CONCRETE SHALL BE PROTECTED FROM DAMAGE BY ALL OPERATIONS AND EQUIPMENT.

15. ALL CONCRETE SHALL BE PROTECTED FROM DAMAGE BY ALL OPERATIONS AND EQUIPMENT. ALL CONCRETE SHALL BE PROTECTED FROM DAMAGE BY ALL OPERATIONS AND EQUIPMENT.

16. ALL CONCRETE SHALL BE PROTECTED FROM DAMAGE BY ALL OPERATIONS AND EQUIPMENT. ALL CONCRETE SHALL BE PROTECTED FROM DAMAGE BY ALL OPERATIONS AND EQUIPMENT.

17. ALL CONCRETE SHALL BE PROTECTED FROM DAMAGE BY ALL OPERATIONS AND EQUIPMENT. ALL CONCRETE SHALL BE PROTECTED FROM DAMAGE BY ALL OPERATIONS AND EQUIPMENT.

18. ALL CONCRETE SHALL BE PROTECTED FROM DAMAGE BY ALL OPERATIONS AND EQUIPMENT. ALL CONCRETE SHALL BE PROTECTED FROM DAMAGE BY ALL OPERATIONS AND EQUIPMENT.

19. ALL CONCRETE SHALL BE PROTECTED FROM DAMAGE BY ALL OPERATIONS AND EQUIPMENT. ALL CONCRETE SHALL BE PROTECTED FROM DAMAGE BY ALL OPERATIONS AND EQUIPMENT.

20. ALL CONCRETE SHALL BE PROTECTED FROM DAMAGE BY ALL OPERATIONS AND EQUIPMENT. ALL CONCRETE SHALL BE PROTECTED FROM DAMAGE BY ALL OPERATIONS AND EQUIPMENT.

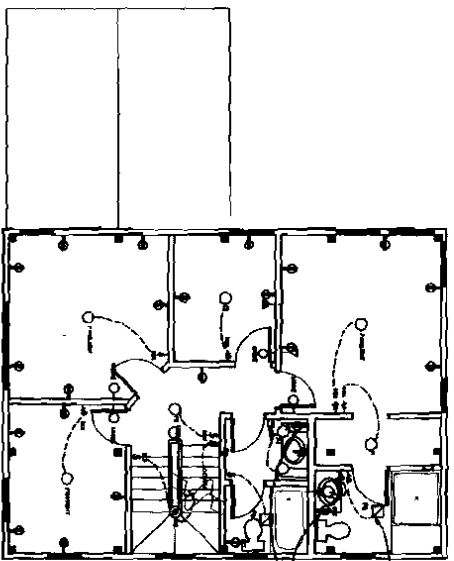
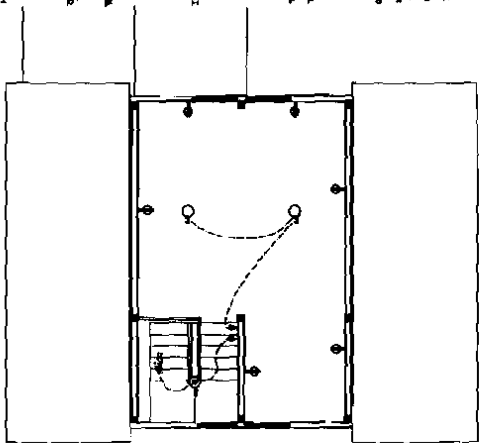

REVISIONS SCHEDULE

NO.	DATE	DESCRIPTION
1		ISSUED FOR PERMITS
2		REVISIONS FOR PERMITS
3		REVISIONS FOR PERMITS
4		REVISIONS FOR PERMITS
5		REVISIONS FOR PERMITS
6		REVISIONS FOR PERMITS
7		REVISIONS FOR PERMITS
8		REVISIONS FOR PERMITS
9		REVISIONS FOR PERMITS
10		REVISIONS FOR PERMITS
11		REVISIONS FOR PERMITS
12		REVISIONS FOR PERMITS
13		REVISIONS FOR PERMITS
14		REVISIONS FOR PERMITS
15		REVISIONS FOR PERMITS
16		REVISIONS FOR PERMITS
17		REVISIONS FOR PERMITS
18		REVISIONS FOR PERMITS
19		REVISIONS FOR PERMITS
20		REVISIONS FOR PERMITS
21		REVISIONS FOR PERMITS
22		REVISIONS FOR PERMITS
23		REVISIONS FOR PERMITS
24		REVISIONS FOR PERMITS
25		REVISIONS FOR PERMITS
26		REVISIONS FOR PERMITS
27		REVISIONS FOR PERMITS
28		REVISIONS FOR PERMITS
29		REVISIONS FOR PERMITS
30		REVISIONS FOR PERMITS
31		REVISIONS FOR PERMITS
32		REVISIONS FOR PERMITS
33		REVISIONS FOR PERMITS
34		REVISIONS FOR PERMITS
35		REVISIONS FOR PERMITS
36		REVISIONS FOR PERMITS
37		REVISIONS FOR PERMITS
38		REVISIONS FOR PERMITS
39		REVISIONS FOR PERMITS
40		REVISIONS FOR PERMITS
41		REVISIONS FOR PERMITS
42		REVISIONS FOR PERMITS
43		REVISIONS FOR PERMITS
44		REVISIONS FOR PERMITS
45		REVISIONS FOR PERMITS
46		REVISIONS FOR PERMITS
47		REVISIONS FOR PERMITS
48		REVISIONS FOR PERMITS
49		REVISIONS FOR PERMITS
50		REVISIONS FOR PERMITS

1 REVISIONS SCHEDULE

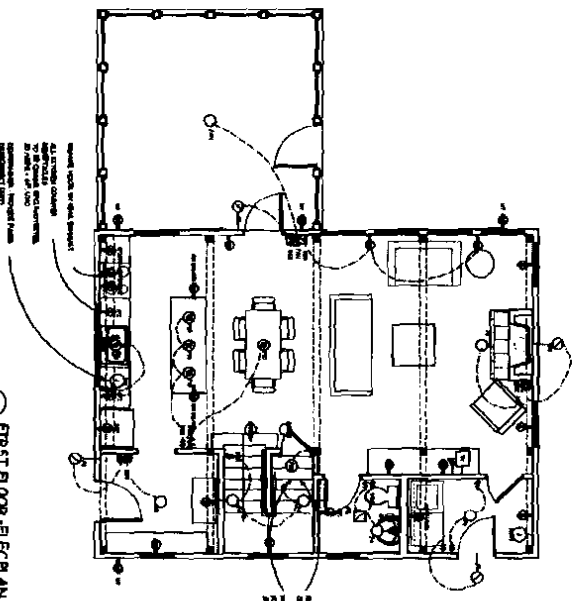

▷ MAP REFERENCE:

- 1) PLAN ENTITLED " SKETCH SHOWING PROPOSED EASEMENTS, DIAMOND COVE PHASE II GREAT DIAMOND ISLAND, PORTLAND, MAINE, " PREPARED FOR MCKINLEY PARTNERS LIMITED PARTNERSHIP, BY LAND USE CONSULTANTS, INC. DATED AUGUST 11, 1995.
- 2) PLAN ENTITLED " AMENDED RECORDING PLAT, DIAMOND COVE PHASE II, SHEET 1 OF 3 GREAT DIAMOND ISLAND, PORTLAND, MAINE, " PREPARED FOR DIAMOND COVE ASSOCIATES, BY LAND USE CONSULTANTS, INC., CCRD PLANBOOK 191 PAGE 143.
- 3) PLAN ENTITLED " UTILITY RECORD DRAWING, DIAMOND COVE PHASE II, WEST SIDE~29 LOTS, SHEET 2 OF 2, " PREPARED FOR MCKINLEY PARTNERS LIMITED PARTNERSHIP, BY LAND USE CONSULTANTS, INC. DATED 06/15/95, THE PLAN IS NOT SEALED AND NOT RECORDED.

GENERAL NOTES

1. THIS PLAN DOES NOT REPRESENT THE RESULTS OF A FIELD SURVEY BY SURVEY AND GEODETIC CONSULTANTS, INC. MONUMENTATION, UTILITIES AND PLANIMETRIC DETAIL SHOWN HEREON IS COMPILED FROM PLANS BY LAND USE CONSULTANTS, INC. (SEE MAP REFERENCES, ABOVE)

2.) THE ARC AT THE REVISED UTILITY EASEMENT BEGINS AT A POINT S 49°19' 23" W, 70.00' FROM POINT "A" AND RUNS IN A CLOCKWISE DIRECTION AT A CONSTANT RADIUS OF 11.14' A DISTANCE OF 32.50', INTENDING TO TERMINATE AT THE INTERSECTION OF THE SPRING COVE LANE RIGHT-OF-WAY.

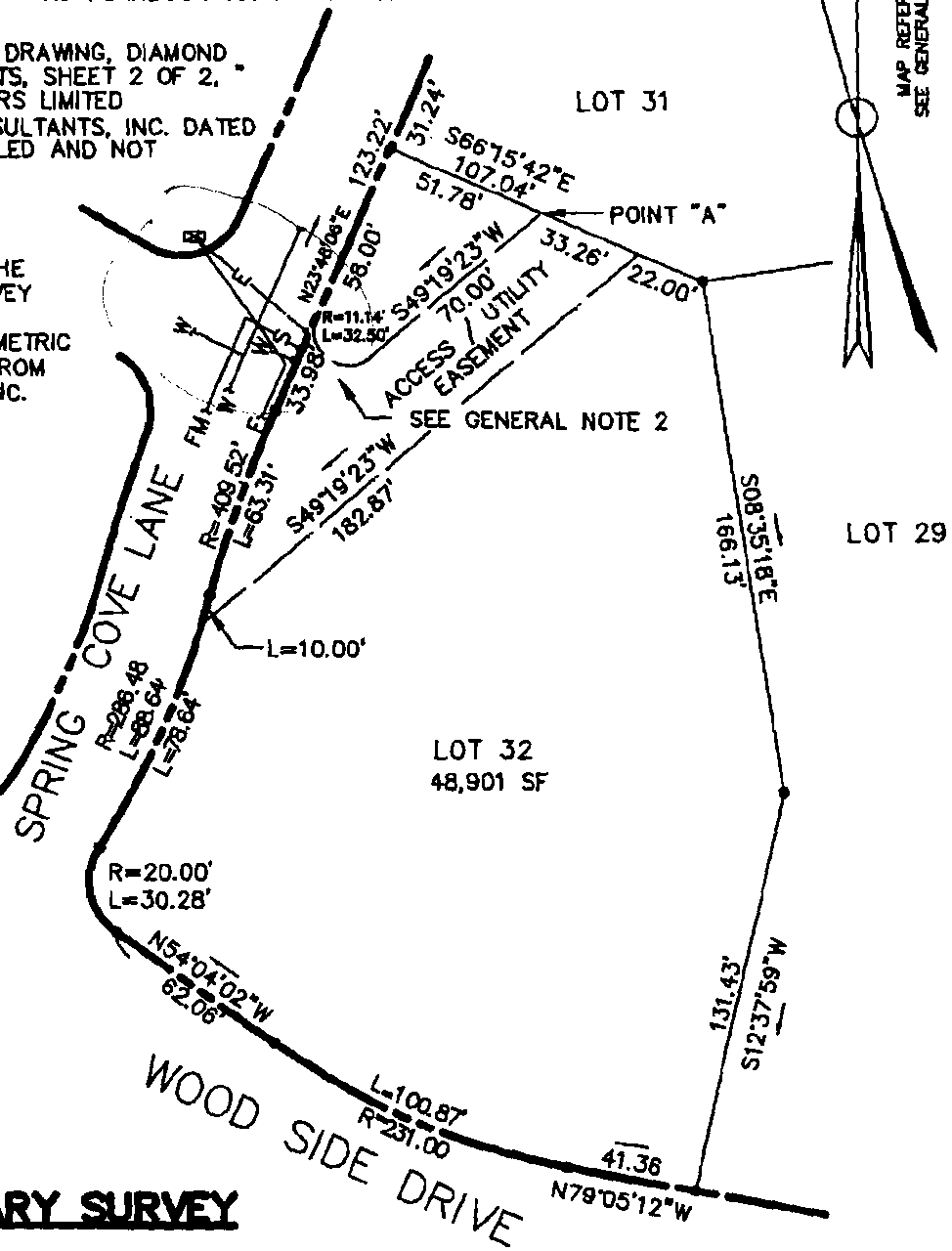

THIS IS NOT A BOUNDARY SURVEY



12 WESTBROOK COMMONS 2nd FLOOR
 WESTBROOK MAINE 04092
 Phone: 207-856-0006 Fax: 207-856-0007

PREPARED FOR:

MCKINLEY PARTNERS
 LIMITED PARTNERSHIP
 GREAT DIAMOND ISLAND
 PORTLAND, MAINE
 CUMBERLAND COUNTY

SCALE: 1" = 60'
DATE: 11/09/99
LUC JOB #: 1420
SGC JOB #: 1-000032.00

TITLE:

ACCESS / UTILITY
 EASEMENT
 SKETCH PLAN

Revised 02/23/00
 Revised 05/25/00

Please call 874-8703 or 874-8693 to schedule your inspections as agreed upon

Permits expire in 6 months, if the project is not started or ceases for 6 months.

The Owner or their designee is required to notify the inspections office for the following inspections and provide adequate notice. Notice must be called in 48-72 hours in advance in order to schedule an inspection:

By initialzing at each inspection time, you are agreeing that you understand the inspection procedure and additional fees from a "Stop Work Order" and "Stop Work Order Release" will be incurred if the procedure is not followed as stated below.

A Pre-construction Meeting will take place upon receipt of your building permit.

- Footing/Building Location Inspection: Prior to pouring concrete
- Re-Bar Schedule Inspection: Prior to pouring concrete
- Foundation Inspection: Prior to placing ANY backfill
- ^{CKW/Inspector} Framing/Rough Plumbing/Electrical: Prior to any insulating or drywalling
- Final/Certificate of Occupancy: Prior to any occupancy of the structure or use. NOTE: There is a \$75.00 fee per inspection at this point.

Certificate of Occupancy is not required for certain projects. Your inspector can advise you if your project requires a Certificate of Occupancy. All projects DO require a final inspection

If any of the inspections do not occur, the project cannot go on to the next phase, REGARDLESS OF THE NOTICE OR CIRCUMSTANCES.

CERTIFICATE OF OCCUPANICES MUST BE ISSUED AND PAID FOR, BEFORE THE SPACE MAY BE OCCUPIED

Coxing, Rick
Signature of Applicant/Designee

9.1.05
Date

Paul J. Adams
Signature of Inspections Official

9.1.05
Date

CBL: 083E A03 Building Permit #: 050947

General Information

The Dutchwest Direct Vent/Natural Vent Room Heater, Model Nos. 3070, 3071, 3072 and 3073, is a vented gas appliance listed to the ANSI standard Z21.88b-2001 and CSA-2.33b-2001 for Vented Room Heaters, and CSA 2.17-M91, Gas-Fired Appliances For Use at High Altitudes.

The installation of the Dutchwest Direct Vent/Natural Vent Room Heater must conform with local codes, or in the absence of local codes, with National Fuel Gas Code, ANSI Z223.1/NFPA 54 — latest edition and CSA B-149.1 Installation Code. (EXCEPTION: Do not derate this appliance for altitude. Maintain the manifold pressure at 3.5" w.c. for Natural Gas and 10.0" w.c. for LP gas at maximum input.)

This appliance is only for use with the type of gas indicated on the rating plate. This appliance is not convertible for use with other gases unless a certified kit is used.

Installation and replacement of gas piping, gas utilization equipment or accessories, and repair and servicing of equipment shall be performed only by a qualified agency. The term "qualified agency" means any individual, firm, corporation, or company that either in person or through a representative is engaged in and is responsible for (a) installation or replacement of gas piping, or (b), the connection, installation, repair, or servicing of equipment, who is experienced in such work, familiar with all precautions required, and has complied with all the requirements of the authority having jurisdiction.

The Dutchwest Direct Vent/Natural Vent Room Heater should be inspected before use and at least annually by a qualified service agency. It is imperative that control compartments, burners, and circulating air passageways of the appliance be kept clean.

The Dutchwest Direct Vent/Natural Vent Room Heater and its individual shut-off valve must be disconnected from the gas supply piping during any pressure testing of that system at test pressures in excess of 1/2 psig (3.5 kPa).

The Dutchwest Direct Vent/Natural Vent Room Heater must be isolated from the gas supply piping system by closing its individual manual shutoff valve during any pressure testing of the gas supply piping system at test pressures equal to or less than 1/2 psig.

'Direct Vent' describes a sealed combustion system in which incoming outside air for combustion and outgoing exhaust enter and exit through two separate concentric passages within the same sealed vent system. The system does not use room air to support combustion. The Direct Vent system permits the gas appliance to be vented directly to the outside atmosphere through the side of the house or vertically through the roof. Conventional venting systems (Natural Vent) take air from the room for combustion and vent the exhaust vertically through the roof to the atmosphere.

This appliance is approved for bedroom installations in the U.S. and Canada.

This appliance may be installed in an aftermarket* manufactured (mobile) home, where not prohibited by state or local codes.

WARNING: Operation of this heater when not connected to a properly installed and maintained venting system can result in carbon monoxide (CO) poisoning and possible death.

The Dutchwest Direct Vent/Natural Vent Room Heater, when installed, must be electrically grounded in accordance with local codes or, in the absence of local codes, with the National Electrical Code ANSI/NFPA 70, (latest edition), or of the current Canadian Electrical Code C22.1.

Due to high temperatures this appliance should be located out of traffic and away from furniture and draperies.

WARNING: This appliance is hot while in operation. Keep children, clothing, and furniture away. Contact may cause burns or ignition of combustible materials.

Children and adults should be alerted to the hazards of high surface temperatures and should stay away to avoid burns or clothing ignition. Young children should be carefully supervised when they are in the same room as the appliance.

Clothing or other flammable materials should not be placed on or near the appliance.

Any safety screen, glass or guard removed for servicing an appliance must be replaced prior to operating the appliance.

The appliance area must be kept clear and free from combustible materials, gasoline, and other flammable vapors and liquids.

The flow of combustion and ventilation air must not be obstructed. The installation must include adequate accessibility and clearance for servicing and proper operation.

WARNING: Do not operate the Room Heater with the glass panel removed, cracked or broken. Replacement of the panel should be done by a licensed or qualified service person.

Do not use this appliance if any part has been under water. Immediately call a qualified service technician to inspect the appliance and to replace any part of the control system and any gas control which has been under water.

Do not burn wood, trash or any other material for which this appliance was not designed. This appliance is designed to burn either natural gas or propane only.

This gas appliance must not be connected to a chimney flue serving a separate solid-fuel burning appliance.

CAUTION: Label all wires prior to disconnection when servicing controls. Wiring errors can cause improper and dangerous operation.

Verify proper operation after servicing.

Proposition 65 Warning: Fuels used in gas, woodburning or oil fired appliances, and the products of combustion of such fuels, contain chemicals known to the State of California to cause cancer, birth defects and other reproductive harm.

California Health & Safety Code Sec. 25249.6

* Aftermarket: Completion of sale, not for purpose of resale, from the manufacturer.

Dutchwest Direct Vent - Natural Vent Dimensions

Refer to Page 6 for Flue Collar
Centerline Dimensions

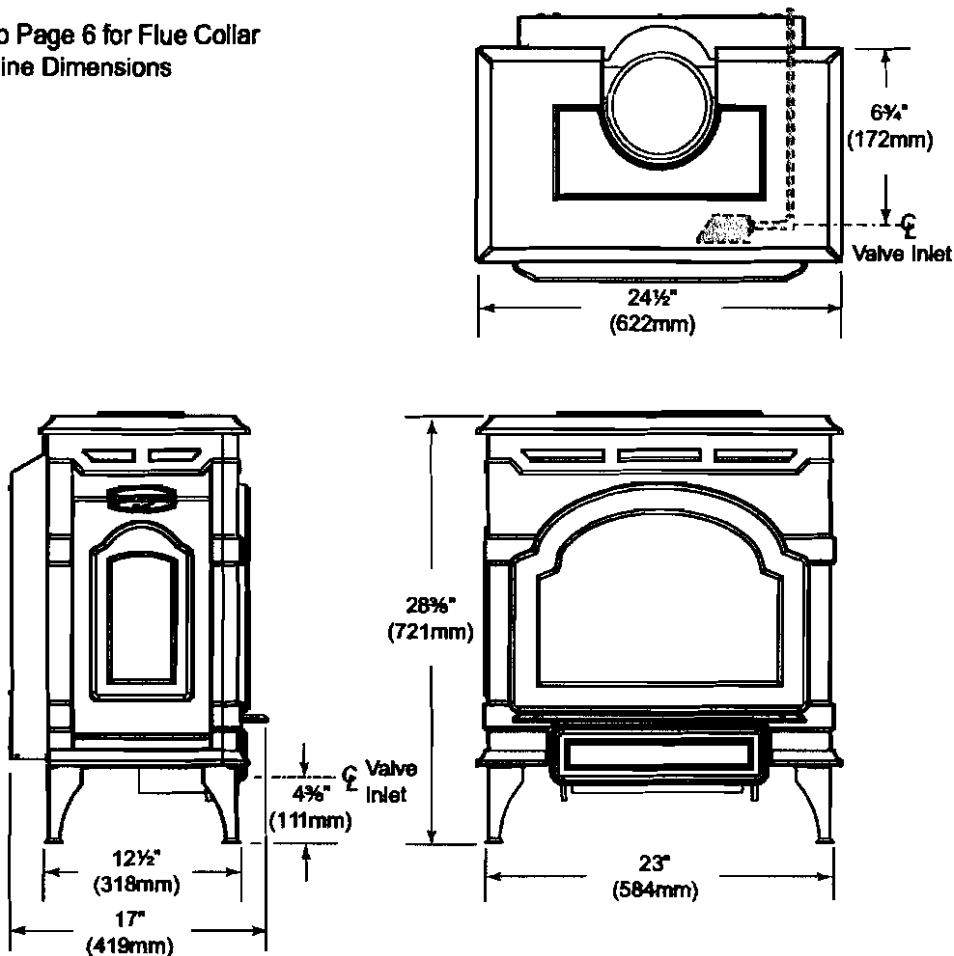

Fig. 1 Dutchwest dimensions.

Attention

The Dutchwest stove is shipped from the factory as a Direct Vent Gas Heater. This heater may be converted into a Natural Vent unit in the field. If a Natural Vent heater is desired, the Z31D00 FSDHAG Draft Hood must be directly installed to the top of the unit according to the Installation instructions. The Draft Hood Adapter is available in the 7FSDHASK stove kit or as a separate item.

When the Dutchwest stove is converted to Natural Vent, it uses 4" vent pipe. For aesthetic purposes the CFM direct vent system may be used up to the ceiling.

Installation Requirements

The installation must conform with local codes or, in the absence of local codes, with the National Fuel Gas Code, ANSI Z223.1/NFPA 54 - latest edition. (EXCEPTION: Do not derate this appliance for altitude. Maintain the manifold pressure at 3.5" w.c. for Natural Gas, and 10" w.c. for Propane).

In Canada, installation must be in accordance with the current CSA B-149.1 Installation Codes and/or local codes.

The installation should be done by a qualified service person who is familiar with the building codes and installation techniques appropriate for your area to accomplish a safe and effective installation.

Your dealer or your local gas supplier will be able to refer a qualified service person.

WARNING: Due to high temperatures, the HEATER should be located out of traffic and away from furniture and draperies.

The surface of the Heater is hot when it is in use. Young children should be watched carefully when they are in the same room when the Heater is in use, and they should be taught to avoid the hot surface. Keep any objects that can burn well away from the Heater, and observe the recommended clearances that follow.

Locating the Stove

In choosing a location for the stove, consider:

- The location of outside walls;
- Where additional heat is needed;
- Where family members gather most often;
- The vent system requirements.

NOTE: We do not recommend the use of wallpaper next to this stove. Over time, radiant heat may cause the wallpaper to shrink, or may adversely affect the binders in the wallpaper adhesive.

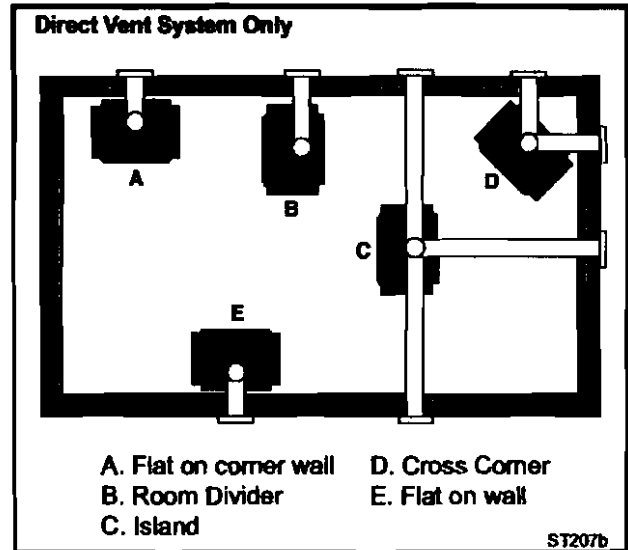

Fig. 2 Possible stove locations.

Clearance Requirements Minimum Clearances to Combustible Materials

Measure side clearances as shown in Figures 5 and 6 from the outer edge of the cast iron stove top. Measure rear clearances from the outermost surface of the steel rear skirt.

The Dutchwest heater is approved for installation into an alcove constructed of combustible materials to the dimensions and clearances shown on the next page. The same clearances apply in a standard parallel installation.

Warning:

- Always maintain required clearances (air spaces) to nearby combustibles to prevent fire hazard. Do not fill air spaces with insulation. All venting components must maintain a 1" (25mm) clearance to combustible materials. Maintain a 6" (150mm) clearance when using a single wall pipe.
- The gas appliance and vent system must be vented directly to the outside of the building and never be attached to a chimney serving a separate solid fuel or gas-burning appliance. Each direct vent appliance must use its own separate vent system. Common vents are prohibited.
- Refer to the manufacturer's instructions included with the venting system for complete installation procedures.

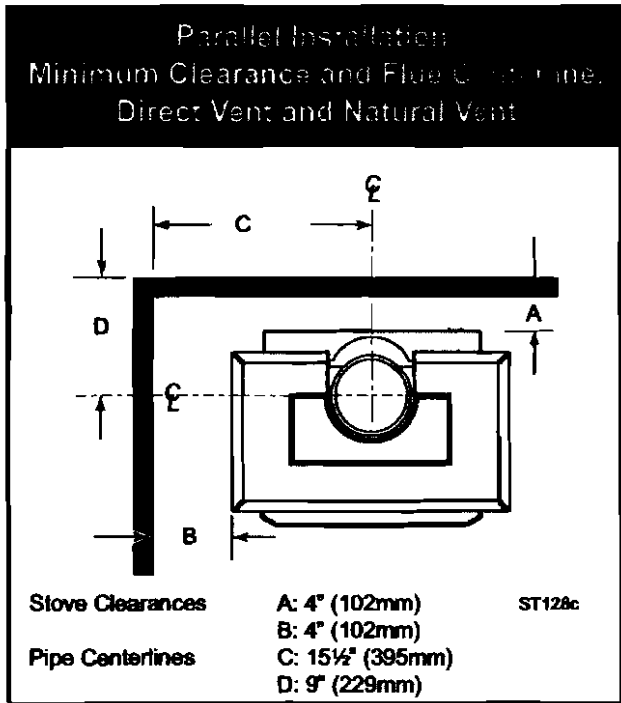

Fig. 3 Parallel installation, minimum back and side clearances and flue centerlines.

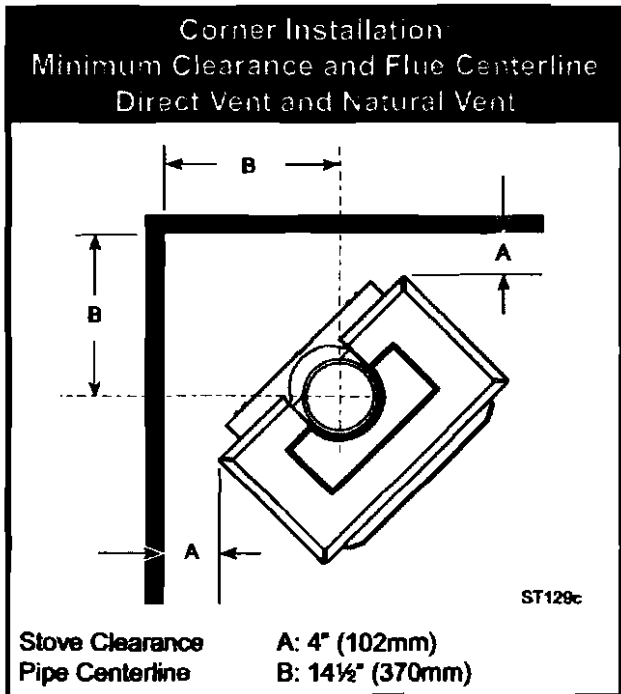

Fig. 4 Corner installation, minimum corner clearances and flue centerline.

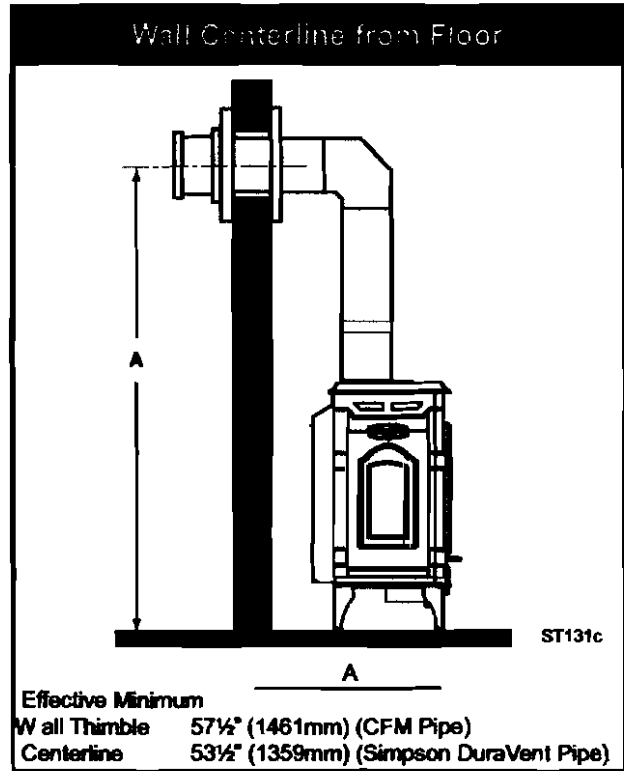

Fig. 5 Minimum wall thimble centerline.

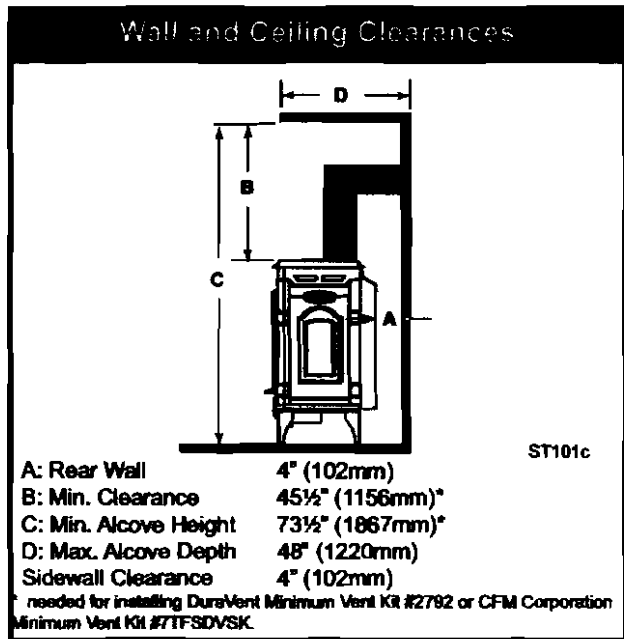

Fig. 6 Dimensions and clearances to ceiling or alcove.

Hearth Requirements

The Dutchwest Heater must be installed on rigid flooring. When the heater is installed directly on any combustible surface other than wood flooring, a metal or wood panel extending the full width and depth of the unit must be used as the hearth. There are no other hearth requirements.

Gas Specifications				
Model	Fuel	Gas Control	Max. Input BTU/h	Min. Input BTU/h
2465	Nat	Millivolt	28,000	20,000
2466	Prop	Millivolt	28,000	19,000

Weight: Fully assembled; 202 lbs.

Gas Inlet and Manifold Pressures		
	Natural	LP (Propane)
Inlet Minimum	5.5" w.c. 1	1.0" w.c.
Inlet Maximum	14.0" w.c.	14.0" w.c.
Manifold Pressure	3.5" w.c.	10.0" w.c.

Dutchwest Direct Vent/Natural Vent Certified to:
ANSI Z21.88a-2003 / CSA 2.33a-2003
Vented Gas Fireplace Heaters

The installation of your Dutchwest stove must conform with local codes or in the absence of local codes, with the National Fuel Gas Code, ANSI Z223.1 NFPA 54 - latest edition, or CSA B149.1 - installation code. **EXCEPTION:** Do not terminate this appliance for a run up to 4,500 feet (1,370m). Maintain the manifold pressure at 3.5" w.c. for Natural Gas and 10.0" w.c. for LP Gas.

High Elevations
 Input ratings are shown in BTU per hour and are certified without restriction for elevations up to 4,500 feet (1,370m) above sea level.
 For elevations above 4,500 feet (1,370m) in USA installations must be in accordance with the current ANSI Z223.1 NFPA 54 and/or local codes having jurisdiction.
 In Canada, please consult provincial and/or local authorities having jurisdiction for installations at elevations above 4,500 feet (1,370m).

WARNING: Improper installation, adjustment, alteration, service or maintenance can cause injury or property damage. Refer to this manual for correct installation and operational procedures. For assistance or additional information consult a qualified installer, service agency, or the gas supplier.

Horizontal Termination - Direct Vent ONLY

The vent must rise vertically a minimum of 24" (610mm) off the top of the unit, before the first elbow. The horizontal run may extend up to 20' (6m) and include a vertical rise of up to 40' (12m). (Fig. 7) Horizontal termination must also meet the criteria shown in Figures 9 through 11.

- Approved vent systems must terminate above and including the heavy line in Figure 7.
- Two 45° elbows may be substituted for each single 90° elbow.
- With a rise between 2' - 5', one 90° or two 45° elbows may be used.

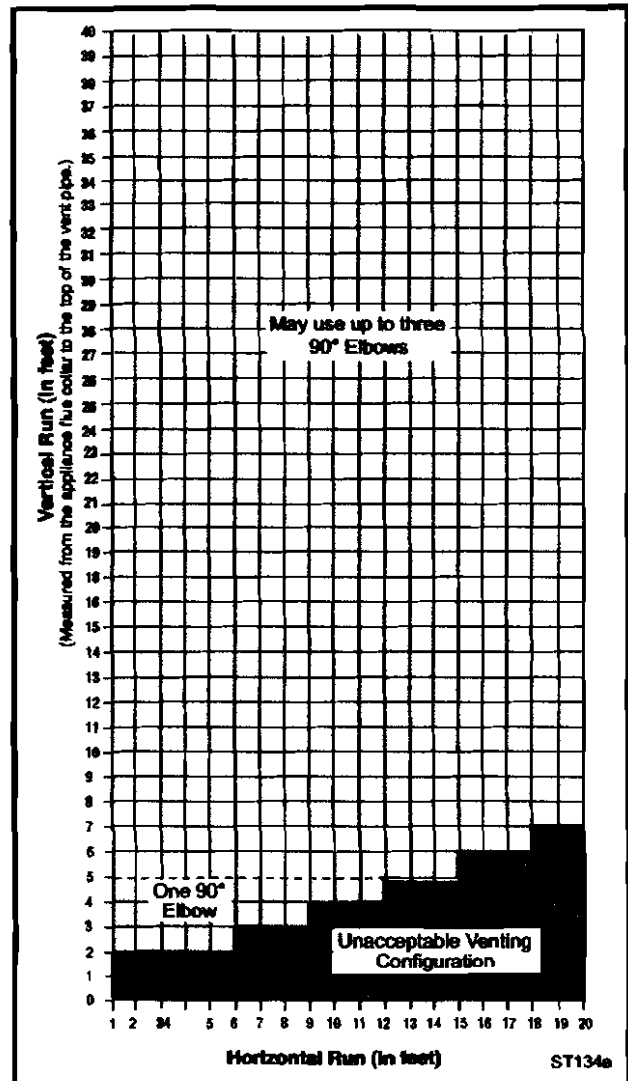

Fig. 7 Horizontal vent termination window.

Vertical Termination - Direct Vent ONLY

A vertical vent system must terminate no less than 8' (2.44m) and no more than 40' (12m) above the appliance flue collar. A 2¼" restrictor plate (supplied) must be used where specified in all vertically terminated vent systems. (Fig. 8) **NOTE: The restrictor plate supplied with the vertical termination should be discarded. Install restrictor plate supplied with stove directly at stove outlet.** A vertically terminated vent system must also conform to the following criteria:

- No more than three 90° elbows may be used.
- Two 45° elbows may be substituted for one 90° elbow. No more than six elbows may be used.
- Vent must rise a minimum of 2 feet before offset is used.
- Termination height must conform to roof clearance as specified in Figure 9.

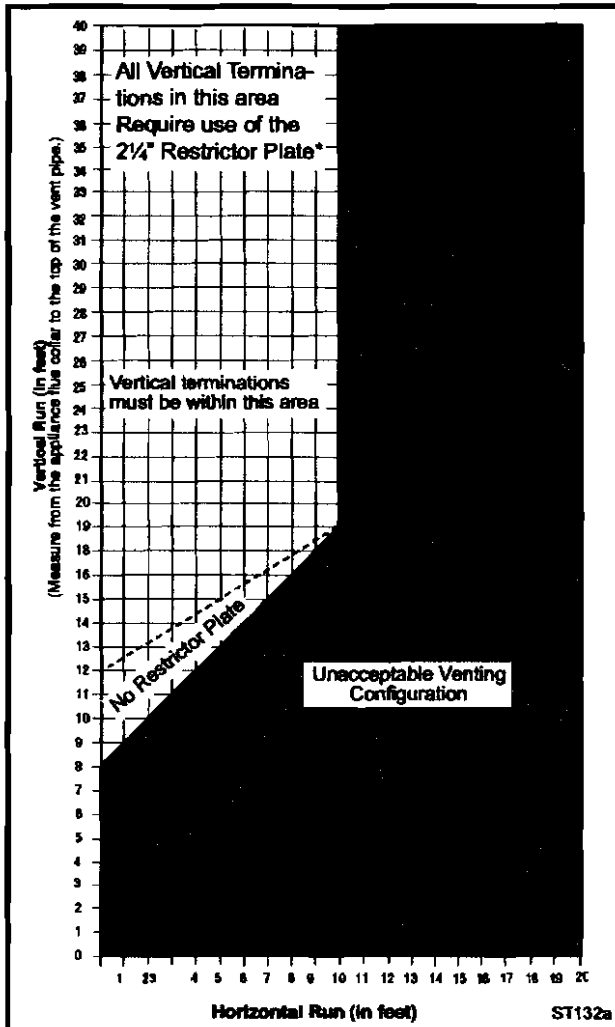

Fig. 8 Vertical vent termination window.

*The Restrictor Plate is used on Direct Vent Installations Only

Vent Termination Clearances

When planning the installation, consider the location of the vent terminal and clearances. Some of the most common clearances to keep in mind are shown in Figure 10.

Important: All vent clearances must be maintained. Check your vent termination clearances against Figures 9 through 11.

The vent should be placed so that people cannot be burned by accidentally touching the vent surfaces when the stove is operating.

The vent termination should be located where it cannot be damaged by such things as automobile doors, lawn mowers or snowblowers and it should be located away from areas where it could become blocked by snow, etc.

Some considerations are:

- Obstructions or impediments to venting.
- Nearby combustible materials that could come into contact with combustion exhaust gases.
- Other nearby openings (within 12" (305mm)) through which exhaust gas could reenter the building.
- All vegetation within 3' ((76mm)) that may interfere with the draft.

Other factors that influence where the installation will be sited include the location of outside walls, where additional heat may be desired in the home, where the family members gather most regularly, and perhaps most importantly, the distance limitations of the venting system.



**IMPORTANT
Direct Vent Only**

- The horizontal termination must not be recessed into the exterior wall or siding.
- Horizontal vent runs must be level toward the vent termination.
- Clearances around the vent termination must be maintained.
- For installations using Simpson DuraVent pipe, parallel installations with minimum wall clearance have restricted access for connecting the Horizontal Vent Cap straps to the vent pipe. See the maker's instructions for recommended installation procedures.

Venting Termination Clearances

Your stove is approved to be vented either through the side wall, or vertical through the roof.

- **This unit does not require any opening for inspection of vent pipe.**
- **Only CFM Corporation and Simpson DuraVent venting components specifically approved and labelled for this stove may be used.**
- **Minimum clearances between vent pipes and combustible materials is one (1") Inch (25 mm), except where stated otherwise.**
- **V**enting terminals shall not be recessed into a wall or siding.
- **H**orizontal venting must be installed on a level plane without an inclining or declining slope.

There must not be any obstruction such as bushes, garden sheds, fences, decks or utility buildings within 24" from the front of the termination hood.

Do not locate termination hood where excessive snow or ice build up may occur. Be sure to check vent termination area after snow falls, and clear to prevent accidental blockage of venting system. When using snow blowers, make sure snow is not directed towards vent termination area.

Location of Vent Termination

It is imperative the vent termination be located observing the minimum clearances as shown on this page.

General Venting Information - Termination Location

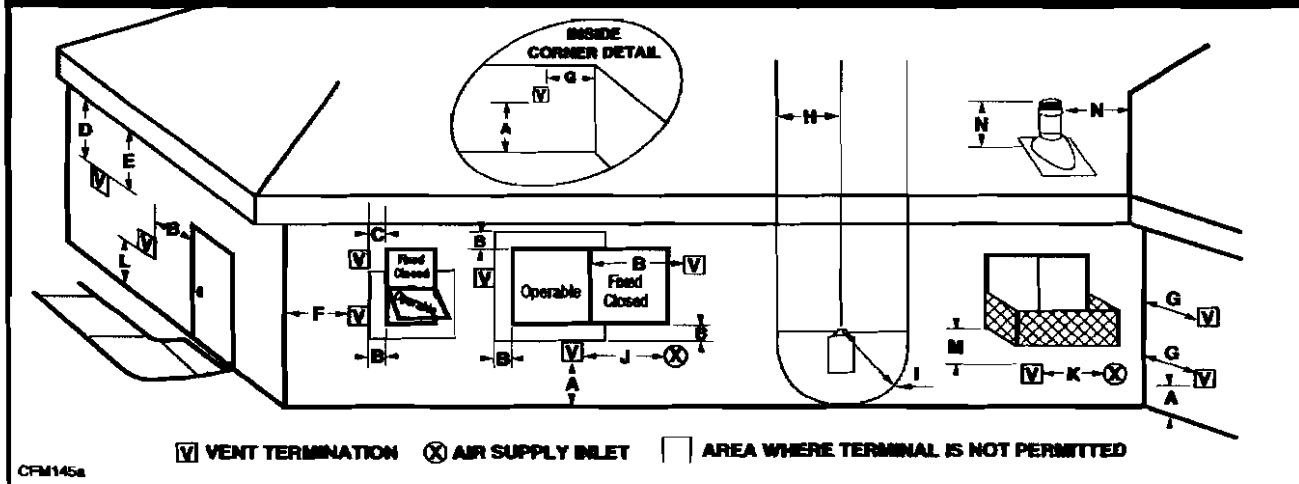

CFM145a

	Canadian Installations ¹	US Installations ²
A = Clearance above grade, veranda, porch, deck, or balcony	12" (30cm)	12" (30cm)
B = Clearance to window or door that may be opened	6" (15cm) for appliances < 10,000 Btuh (3kW), 12" (30cm) for appliances > 10,000 Btuh (3kW) and < 100,000 Btuh (30kW), 36" (91cm) for appliances > 100,000 Btuh (30kW) appliances > 50,000 Btuh (15kW)	6" (15cm) for appliances < 10,000 Btuh (3kW), 9" (23cm) for appliances > 10,000 Btuh (3kW) and < 50,000 Btuh (15kW), 12" (30cm) for appliances > 50,000 Btuh (15kW)
C = Clearance to permanently closed window	12" (305mm) recommended to prevent window condensation	12" (305mm) recommended to prevent window condensation
D = Vertical clearance to ventilated soffit located above the terminal within a horizontal distance of 2 feet (610mm) from the center line of the terminal	18" (458mm)	18" (458mm)
E = Clearance to unventilated soffit	12" (305mm)	12" (305mm)
F = Clearance to outside corner	see next page	see next page
G = Clearance to inside corner (see next page)	see next page	see next page
H = Clearance to each inside of center line extended above meter/regulator assembly	3' (91cm) within a height of 15' (5m) above the meter/regulator assembly	3' (91cm) within a height of 15' (5m) above the meter/regulator assy
I = Clearance to service regulator vent outlet	3' (91cm)	3' (91cm)
J = Clearance to nonmechanical air supply inlet to building or the combustion air inlet to any other appliances	6" (15cm) for appliances < 10,000 Btuh (3kW), 12" (30cm) for appliances > 10,000 Btuh (3kW) and < 100,000 Btuh (30kW), 36" (91cm) for appliances > 100,000 Btuh (30kW)	6" (15cm) for appliances < 10,000 Btuh (3kW), 9" (23cm) for appliances > 10,000 Btuh (3kW) and < 50,000 Btuh (15kW), 12" (30cm) for appliances > 50,000 Btuh (15kW)
K = Clearance to a mechanical air supply inlet	6' (1.83m)	3' (91cm) above if within 10' (3m) horizontally
L = Clearance above paved sidewalk or paved driveway located on public property	7' (2.13m)†	7' (2.13m)†
M = Clearance under veranda, porch, deck or balcony	12" (30cm)‡	12" (30cm)‡
N = Clearance above a roof shall extend a minimum of 24" (610mm) above the highest point when it passes through the roof surface, and any other obstruction within a horizontal distance of 18" (450mm).		

1 In accordance with the current CSA-B149 Installation Codes
 2 In accordance with the current ANSI Z223.1/NFPA 54 National Fuel Gas Codes
 † A vent shall not terminate directly above a sidewalk or paved driveway which is located between two single family dwellings and serves both dwellings
 ‡ only permitted if veranda, porch, deck or balcony is fully open on a minimum 2 sides beneath the floor.
 NOTE: 1. Local codes or regulations may require different clearances.
 2. The special venting system used on Direct Vent appliances are certified as part of the appliance, with clearances tested and approved by the listing agency.

Fig. 9 Vent termination clearances.

SUBSURFACE WASTEWATER DISPOSAL SYSTEM APPLICATION

Division of Health Engineering, 10 SHS
(207) 287-5672 Fax: (207) 287-3165

PROPERTY LOCATION		>> CAUTION: PERMIT REQUIRED - ATTACH IN SPACE BELOW <<
City, Town, or Plantation	PORTLAND / DIAMOND COVE	
Street or Road	SPRING COVE LANE	
Subdivision, Lot #	LOT NO. 31	
OWNER/APPLICANT INFORMATION		The Subsurface Wastewater Disposal System <i>shall not</i> be installed until a Permit is attached HERE by the Local Plumbing Inspector. The Permit shall authorize the owner or installer to install the disposal system in accordance with this application and the Maine Subsurface Wastewater Disposal Rules.
Name (last, first, MI)		
RICKARBYE, RYAN <input checked="" type="checkbox"/> Owner <input type="checkbox"/> Applicant		
Mailing Address of Owner/Applicant		
3 COUNTRY FARM RD. STRATHAM, N.H. 03885		
Daytime Tel. #	1-603-772-4446	Municipal Tax Map #83E-A Lot # 31
OWNER OR APPLICANT STATEMENT		CAUTION: INSPECTION REQUIRED
I state and acknowledge that the information submitted is correct to the best of my knowledge and understand that any falsification is reason for the Department and/or Local Plumbing Inspector to deny a Permit.		I have inspected the installation authorized above and found it to be in compliance with the Subsurface Wastewater Disposal Rules Application.
Signature of Owner or Applicant: <u>Richard Rickarbye</u> Date: <u>7.7.05</u>		Local Plumbing Inspector Signature: _____ (1st) date approved: _____
Signature of Owner or Applicant: _____ Date: _____		Local Plumbing Inspector Signature: _____ (2nd) date approved: _____

PERMIT INFORMATION		
TYPE OF APPLICATION <input checked="" type="checkbox"/> 1. First Time System <input type="checkbox"/> 2. Replacement System Type replaced: _____ Year installed: _____ <input type="checkbox"/> 3. Expanded System <input type="checkbox"/> a. Minor Expansion <input type="checkbox"/> b. Major Expansion <input type="checkbox"/> 4. Experimental System <input type="checkbox"/> 5. Seasonal Conversion	THIS APPLICATION REQUIRES <input checked="" type="checkbox"/> 1. No Rule Variance <input type="checkbox"/> 2. First Time System Variance <input type="checkbox"/> a. Local Plumbing Inspector Approval <input type="checkbox"/> b. State & Local Plumbing Inspector Approval <input type="checkbox"/> 3. Replacement System Variance <input type="checkbox"/> a. Local Plumbing Inspector Approval <input type="checkbox"/> b. State & Local Plumbing Inspector Approval <input type="checkbox"/> 4. Minimum Lot Size Variance <input type="checkbox"/> 5. Seasonal Conversion Permit	DISPOSAL SYSTEM COMPONENTS <input checked="" type="checkbox"/> 1. Complete Non-engineered System <input type="checkbox"/> 2. Primitive System (graywater & alt. toilet) <input type="checkbox"/> 3. Alternative Toilet, specify: _____ <input type="checkbox"/> 4. Non-engineered Disposal Area <input type="checkbox"/> 5. Holding Tank, _____ gallons <input type="checkbox"/> 6. Non-engineered Disposal Field (only) <input type="checkbox"/> 7. Separated Laundry System <input type="checkbox"/> 8. Complete Engineered System (2000 gpd or more) <input type="checkbox"/> 9. Engineered Treatment Tank (only) <input type="checkbox"/> 10. Engineered Disposal Field (only) <input type="checkbox"/> 11. Pre-treatment, specify: _____ <input type="checkbox"/> 12. Miscellaneous Components
SIZE OF PROPERTY 40,743 <input checked="" type="checkbox"/> SQ. FT. <input type="checkbox"/> ACRES	DISPOSAL SYSTEM TO SERVE <input checked="" type="checkbox"/> 1. Single Family Dwelling Unit, No. of Bedrooms: <u>3</u> <input type="checkbox"/> 2. Multiple Family Dwelling, No. of Units: _____ <input type="checkbox"/> 3. Other: _____ (specify) Current Use <input type="checkbox"/> Seasonal <input type="checkbox"/> Year Round <input checked="" type="checkbox"/> Undeveloped	TYPE OF WATER SUPPLY <input type="checkbox"/> 1. Drilled Well <input type="checkbox"/> 2. Dug Well <input type="checkbox"/> 3. Private <input checked="" type="checkbox"/> 4. Public <input type="checkbox"/> 5. Other

DESIGN DETAILS (SYSTEM LAYOUT SHOWN ON PAGE 3)			
TREATMENT TANK <input checked="" type="checkbox"/> 1. Concrete <input checked="" type="checkbox"/> a. Regular <input type="checkbox"/> b. Low Profile <input type="checkbox"/> 2. Plastic <input type="checkbox"/> 3. Other: _____ CAPACITY: <u>1000</u> GAL.	DISPOSAL FIELD TYPE & SIZE <input type="checkbox"/> 1. Stone Bed <input type="checkbox"/> 2. Stone Trench <input checked="" type="checkbox"/> 3. Proprietary Device <input type="checkbox"/> a. cluster array <input checked="" type="checkbox"/> c. Linear <input checked="" type="checkbox"/> b. regular load <input type="checkbox"/> d. H-20 load <input type="checkbox"/> 4. Other: _____ SIZE: <u>900</u> <input type="checkbox"/> sq. ft. <input type="checkbox"/> lin. ft.	GARBAGE DISPOSAL UNIT <input checked="" type="checkbox"/> 1. No <input type="checkbox"/> 2. Yes <input type="checkbox"/> 3. Maybe If Yes or Maybe, specify one below: <input type="checkbox"/> a. multi-compartment tank <input type="checkbox"/> b. _____ tanks in series <input type="checkbox"/> c. increase in tank capacity <input type="checkbox"/> d. Filter on Tank Outlet	DESIGN FLOW <u>270</u> gallons per day BASED ON: <input checked="" type="checkbox"/> 1. Table 501.1 (dwelling unit(s)) <input type="checkbox"/> 2. Table 501.2 (other facilities) SHOW CALCULATIONS — for other facilities —
SOIL DATA & DESIGN CLASS PROFILE CONDITION DESIGN <u>Z, AUC/C, 1</u> at Observation Hole # <u>56</u> Depth <u>22"</u> of Most Limiting Soil Factor <u>ROCK</u>	DISPOSAL FIELD SIZING <input type="checkbox"/> 1. Small—2.0 sq. ft. / gpd <input type="checkbox"/> 2. Medium—2.6 sq. ft. / gpd <input checked="" type="checkbox"/> 3. Medium—Large 3.3 sq. ft. / gpd <input type="checkbox"/> 4. Large—4.1 sq. ft. / gpd <input type="checkbox"/> 5. Extra Large—5.0 sq. ft. / gpd	EFFLUENT/EJECTOR PUMP <input type="checkbox"/> 1. Not Required <input type="checkbox"/> 2. May Be Required <input checked="" type="checkbox"/> 3. Required Specify only for engineered systems: DOSE: _____ gallons	<input type="checkbox"/> 3. Section 503.0 (meter readings) ATTACH WATER METER DATA

SITE EVALUATOR STATEMENT		
I certify that on <u>4/15/05</u> (date) I completed a site evaluation on this property and state that the data reported are accurate and that the proposed system is in compliance with the State of Maine Subsurface Wastewater Disposal Rules (10-144A CMR 241).		
<u>David A. Kamila</u> Site Evaluator Signature	<u>185</u> SE #	<u>4/15/05</u> Date
<u>DAVID A. KAMILA</u> Site Evaluator Name Printed		

Note: Changes to or deviations from the design should be confirmed with the Site Evaluator.

SUBSURFACE WASTEWATER DISPOSAL SYSTEM APPLICATION

Maine Department of Human Services
Division of Health Engineering, Station 10
(207) 287-5672 FAX (207) 287-4172

Town, City, Plantation

Street, Road, Subdivision

Owner or Applicant Name

PORTLAND/DIAMOND COVE

SPRING COVE LANE

RYAN RICKERBIE

SITE PLAN

Scale: 1" = 100 Ft.
or as shown

SITE LOCATION PLAN
(Map from The Maine Atlas recommended)

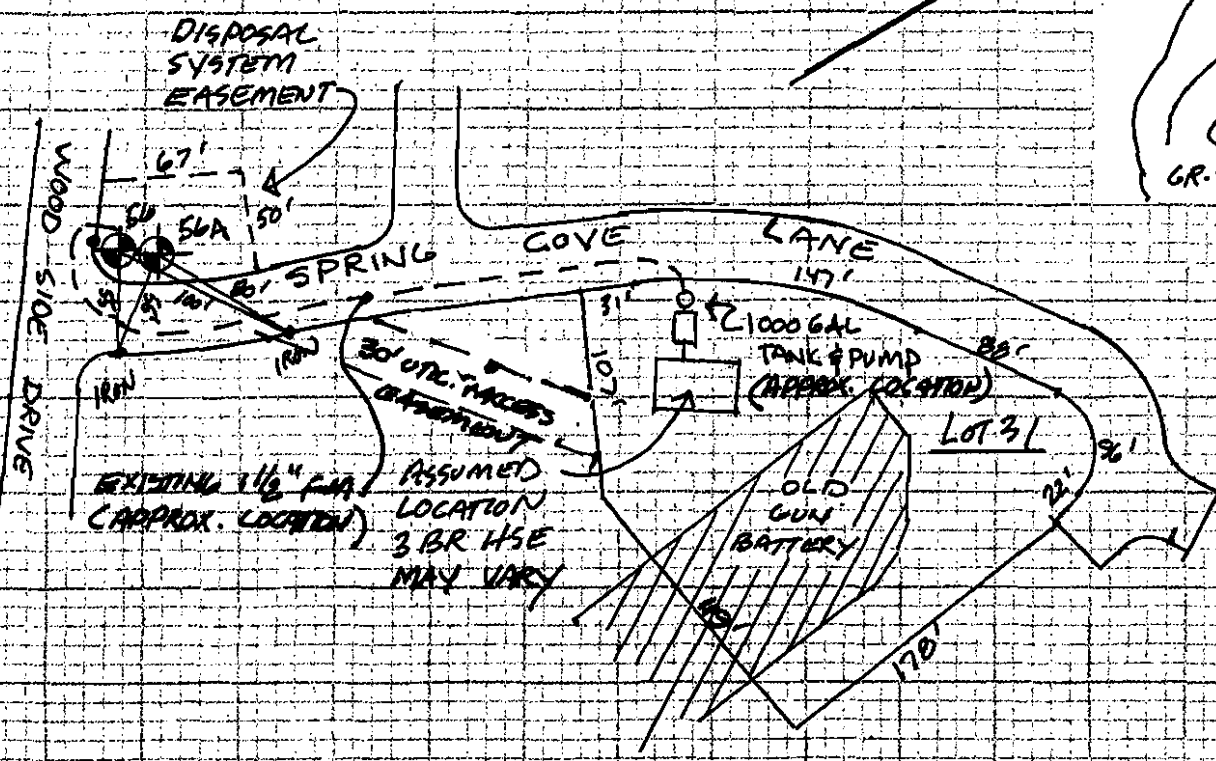
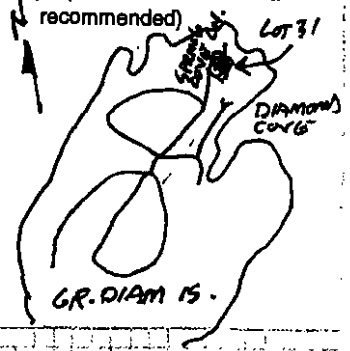

SOIL DESCRIPTION AND CLASSIFICATION

(Location of Observation Holes Shown Above)

Observation Hole 56a Test Pit Boring
2" Depth of Organic Horizon Above Mineral Soil

DEPTH BELOW MINERAL SOIL SURFACE (Inches)	Texture	Consistency	Color	Mottling
0			DARK BROWN	
8	FINE	FRIABLE		
10	SANDY	LOOSE	REDDISH	NONE
15	LOAM		BROWN	
20				
25	X X	X X	X X	X X
30		BEDROCK		
40				
50				

Soil Profile	Class	Slope	Limiting Factor	<input type="checkbox"/> Ground Water
<u>Z</u>	<u>AUIC</u>	<u>1%</u>	<u>22</u>	<input type="checkbox"/> Restrictive Layer
				<input checked="" type="checkbox"/> Bedrock

Observation Hole 56A Test Pit Boring
2" Depth of Organic Horizon Above Mineral Soil

DEPTH BELOW MINERAL SOIL SURFACE (Inches)	Texture	Consistency	Color	Mottling
0			DARK BROWN	
6	FINE	FRIABLE		
10	SANDY	LOOSE	BROWN	
15	LOAM			
20				
25				
30	X X X	X X X	X X X	COMM. DIST.
35		BEDROCK		
40				
50				

Soil Profile	Class	Slope	Limiting Factor	<input type="checkbox"/> Ground Water
<u>Z</u>	<u>AUIC</u>	<u>7%</u>	<u>20</u>	<input type="checkbox"/> Restrictive Layer
				<input type="checkbox"/> Bedrock

David A. Kainle
Site Evaluator Signature

185
SE #

4/15/05*
Date

*ORIG. TEST PITS EVALUATED 10/17/84 CONFIRMED 4/15/05

SUBSURFACE WASTEWATER DISPOSAL SYSTEM APPLICATION

Maine Department of Human Services
Division of Health Engineering, Station 10
(207) 287-8672 FAX (207) 287-4172

Town, City, Plantation: **PORTLAND / DIAMOND COVE** Street, Road, Subdivision: **SPRING COVE LANE / LOT 31** Owner or Applicant Name: **RYAN RICKER BIE**

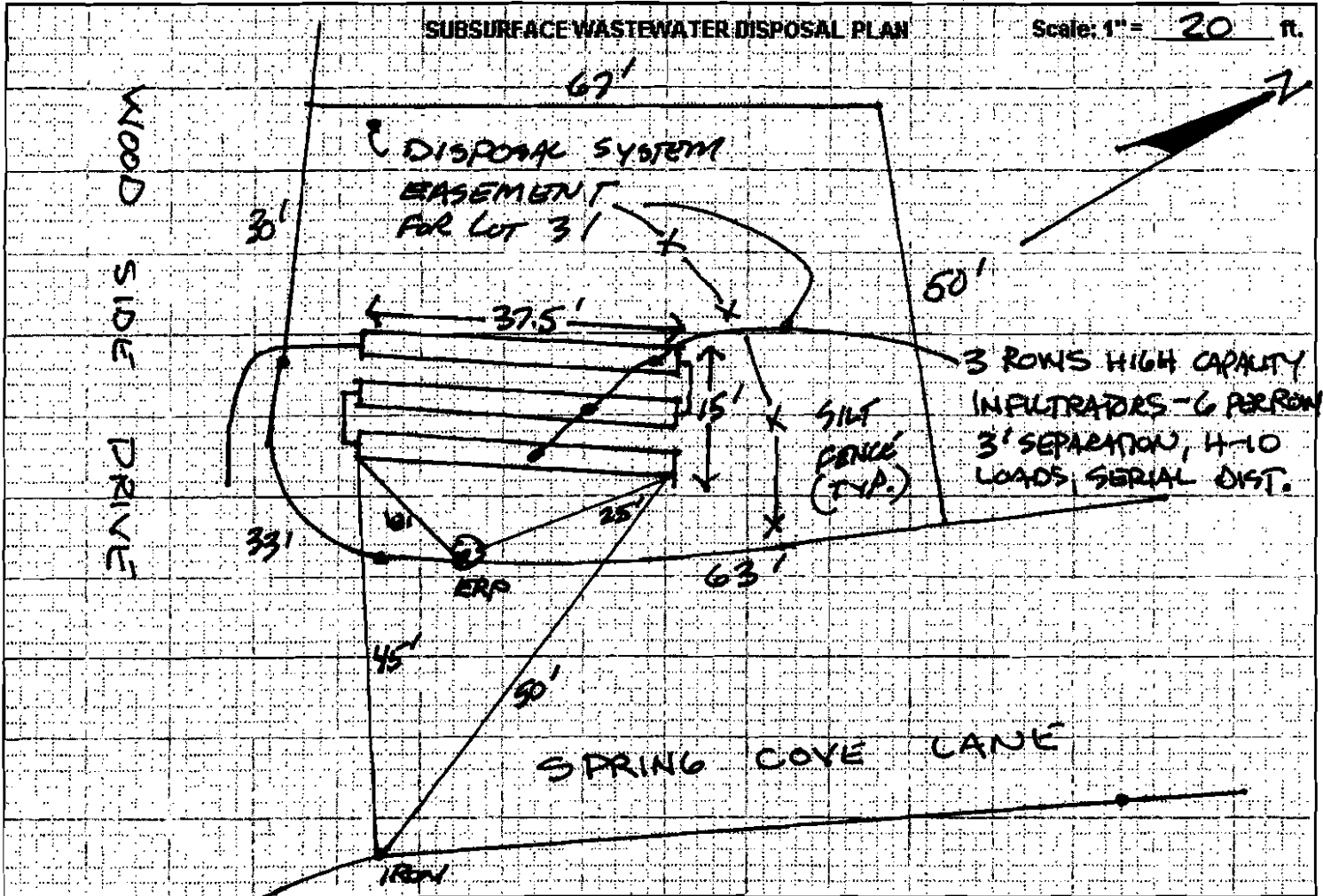

BACKFILL REQUIREMENTS

Depth of Backfill (upslope) 36"
Depth of Backfill (downslope) 24"
DEPTHS AT CROSS-SECTION (shown below)

CONSTRUCTION ELEVATIONS

Finished Grade Elevation SEB
Top of Distribution Pipes or Proprietary Device SET
Bottom of Disposal Field BELOW

ELEVATION REFERENCE POINT

Location & Description: HARD NAIL IN 8" BARCH 54" ABOVE GROUND
Reference Elevation is: 0.0" or _____

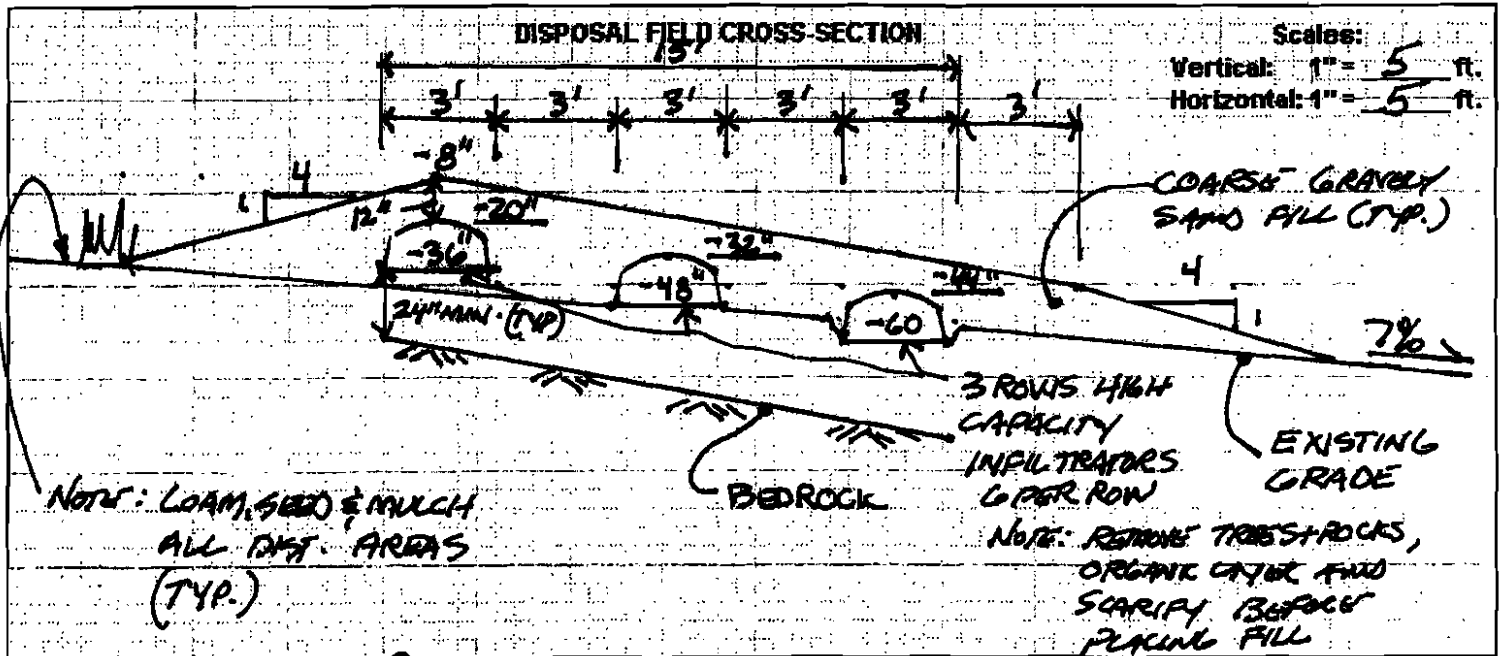

David A. Kaul
Site Evaluator Signature

185
SE #

4/15/05
Date

SUBSURFACE WASTEWATER DISPOSAL SYSTEM APPLICATION

Division of Health Engineering, 10 SHS
(207) 287-5672 Fax: (207) 287-3165

PROPERTY LOCATION		>> CAUTION: PERMIT REQUIRED - ATTACH IN SPACE BELOW <<
City, Town, or Plantation	PORTLAND / DIAMOND COVE	The Subsurface Wastewater Disposal System <i>shall not</i> be installed until a Permit is attached HERE by the Local Plumbing Inspector. The Permit shall authorize the owner or installer to install the disposal system in accordance with this application and the Maine Subsurface Wastewater Disposal Rules.
Street or Road	SPRING COVE LANE	
Subdivision, Lot #	Lot No. 31	
OWNER/APPLICANT INFORMATION		
Name (last, first, MI)	RICKARBYE, RYAN <input checked="" type="checkbox"/> Owner <input type="checkbox"/> Applicant	
Mailing Address of Owner/Applicant	3 COUNTRY FARM RD. STRATHAM, N.H. 03885	
Daytime Tel. #	1-603-272-4446	Municipal Tax Map # <u>83E-A</u> Lot # <u>31</u>
OWNER OR APPLICANT STATEMENT		CAUTION: INSPECTION REQUIRED
I state and acknowledge that the information submitted is correct to the best of my knowledge and understand that any falsification is reason for the Department and/or Local Plumbing Inspector to deny a Permit.		I have inspected the installation authorized above and found it to be in compliance with the Subsurface Wastewater Disposal Rules Application.
Signature of Owner or Applicant: <u>William Rickarbye</u> Date: <u>7.7.05</u>		Local Plumbing Inspector Signature: _____ (1st) date approved: _____ _____ (2nd) date approved: _____

PERMIT INFORMATION		
TYPE OF APPLICATION <input checked="" type="checkbox"/> 1. First Time System <input type="checkbox"/> 2. Replacement System Type replaced: _____ Year installed: _____ <input type="checkbox"/> 3. Expanded System <input type="checkbox"/> a. Minor Expansion <input type="checkbox"/> b. Major Expansion <input type="checkbox"/> 4. Experimental System <input type="checkbox"/> 5. Seasonal Conversion	THIS APPLICATION REQUIRES <input checked="" type="checkbox"/> 1. No Rule Variance <input type="checkbox"/> 2. First Time System Variance <input type="checkbox"/> a. Local Plumbing Inspector Approval <input type="checkbox"/> b. State & Local Plumbing Inspector Approval <input type="checkbox"/> 3. Replacement System Variance <input type="checkbox"/> a. Local Plumbing Inspector Approval <input type="checkbox"/> b. State & Local Plumbing Inspector Approval <input type="checkbox"/> 4. Minimum Lot Size Variance <input type="checkbox"/> 5. Seasonal Conversion Permit	DISPOSAL SYSTEM COMPONENTS <input checked="" type="checkbox"/> 1. Complete Non-engineered System <input type="checkbox"/> 2. Primitive System (graywater & silt. toilet) <input type="checkbox"/> 3. Alternative Toilet, specify: _____ <input type="checkbox"/> 4. Non-engineered Disposal Area <input type="checkbox"/> 5. Holding Tank, _____ gallons <input type="checkbox"/> 6. Non-engineered Disposal Field (only) <input type="checkbox"/> 7. Separated Laundry System <input type="checkbox"/> 8. Complete Engineered System (2000 gpd or more) <input type="checkbox"/> 9. Engineered Treatment Tank (only) <input type="checkbox"/> 10. Engineered Disposal Field (only) <input type="checkbox"/> 11. Pre-treatment, specify: _____ <input type="checkbox"/> 12. Miscellaneous Components
SIZE OF PROPERTY <u>40,743</u> <input checked="" type="checkbox"/> SQ. FT. <input type="checkbox"/> ACRES	DISPOSAL SYSTEM TO SERVE <input checked="" type="checkbox"/> 1. Single Family Dwelling Unit, No. of Bedrooms: <u>3</u> <input type="checkbox"/> 2. Multiple Family Dwelling, No. of Units: _____ <input type="checkbox"/> 3. Other: _____ (specify) Current Use <input type="checkbox"/> Seasonal <input type="checkbox"/> Year Round <input checked="" type="checkbox"/> Undeveloped	TYPE OF WATER SUPPLY <input type="checkbox"/> 1. Drilled Well <input type="checkbox"/> 2. Dug Well <input type="checkbox"/> 3. Private <input checked="" type="checkbox"/> 4. Public <input type="checkbox"/> 5. Other

DESIGN DETAILS (SYSTEM LAYOUT SHOWN ON PAGE 3)			
TREATMENT TANK <input checked="" type="checkbox"/> 1. Concrete <input checked="" type="checkbox"/> a. Regular <input type="checkbox"/> b. Low Profile <input type="checkbox"/> 2. Plastic <input type="checkbox"/> 3. Other: _____ CAPACITY: <u>1000</u> GAL	DISPOSAL FIELD TYPE & SIZE <input type="checkbox"/> 1. Stone Bed <input type="checkbox"/> 2. Stone Trench <input checked="" type="checkbox"/> 3. Proprietary Device <input type="checkbox"/> a. cluster array <input checked="" type="checkbox"/> c. Linear <input checked="" type="checkbox"/> b. regular load <input type="checkbox"/> d. H-20 load <input type="checkbox"/> 4. Other: _____ SIZE: <u>900</u> <input type="checkbox"/> sq. ft. <input type="checkbox"/> lin. ft.	GARBAGE DISPOSAL UNIT <input checked="" type="checkbox"/> 1. No <input type="checkbox"/> 2. Yes <input type="checkbox"/> 3. Maybe If Yes or Maybe, specify one below: <input type="checkbox"/> a. multi-compartment tank <input type="checkbox"/> b. _____ tanks in series <input type="checkbox"/> c. Increase in tank capacity <input type="checkbox"/> d. Filter on Tank Outlet	DESIGN FLOW <u>270</u> gallons per day BASED ON: <input checked="" type="checkbox"/> 1. Table 501.1 (dwelling unit(s)) <input type="checkbox"/> 2. Table 501.2 (other facilities) SHOW CALCULATIONS --- for other facilities ---
SOIL DATA & DESIGN CLASS PROFILE CONDITION DESIGN <u>2 / A1/C1</u> at Observation Hole # <u>56</u> Depth <u>22</u> of Most Limiting Soil Factor <u>BEDROCK</u>	DISPOSAL FIELD SIZING <input type="checkbox"/> 1. Small—2.0 sq. ft. / gpd <input type="checkbox"/> 2. Medium—2.8 sq. ft. / gpd <input checked="" type="checkbox"/> 3. Medium—Large 3.3 sq. ft. / gpd <input type="checkbox"/> 4. Large—4.1 sq. ft. / gpd <input type="checkbox"/> 5. Extra Large—5.0 sq. ft. / gpd	EFFLUENT/EJECTOR PUMP <input type="checkbox"/> 1. Not Required <input type="checkbox"/> 2. May Be Required <input checked="" type="checkbox"/> 3. Required Specify only for engineered systems: DOSE: _____ gallons	<input type="checkbox"/> 3. Section 503.0 (meter readings) ATTACH WATER METER DATA

SITE EVALUATOR STATEMENT		
I certify that on <u>4/15/05</u> (date) I completed a site evaluation on this property and state that the data reported are accurate and that the proposed system is in compliance with the State of Maine Subsurface Wastewater Disposal Rules (10-144A CMR 241).		
Signature: <u>David A. Kamila</u> Site Evaluator Signature	SE #: <u>185</u>	Date: <u>4/15/05</u>

DAVID A. KAMILA
Site Evaluator Name Printed

Note: Changes to or deviations from the design should be confirmed with the Site Evaluator.

Page 1 of 3
HHE-200 Rev. 8/01

SUBSURFACE WASTEWATER DISPOSAL SYSTEM APPLICATION

Maine Department of Human Services
 Division of Health Engineering, Station 10
 (207) 287-5672 FAX (207) 287-4172

Town, City, Plantation: **PORTLAND/DIAMOND COVE** Street, Road, Subdivision: **SPRING COVE LANE** Owner or Applicant Name: **RYAN RICKERBIE**

SITE PLAN

Scale: 1" = 100 Ft.
 or as shown

SITE LOCATION PLAN

(Map from The Maine Atlas recommended)

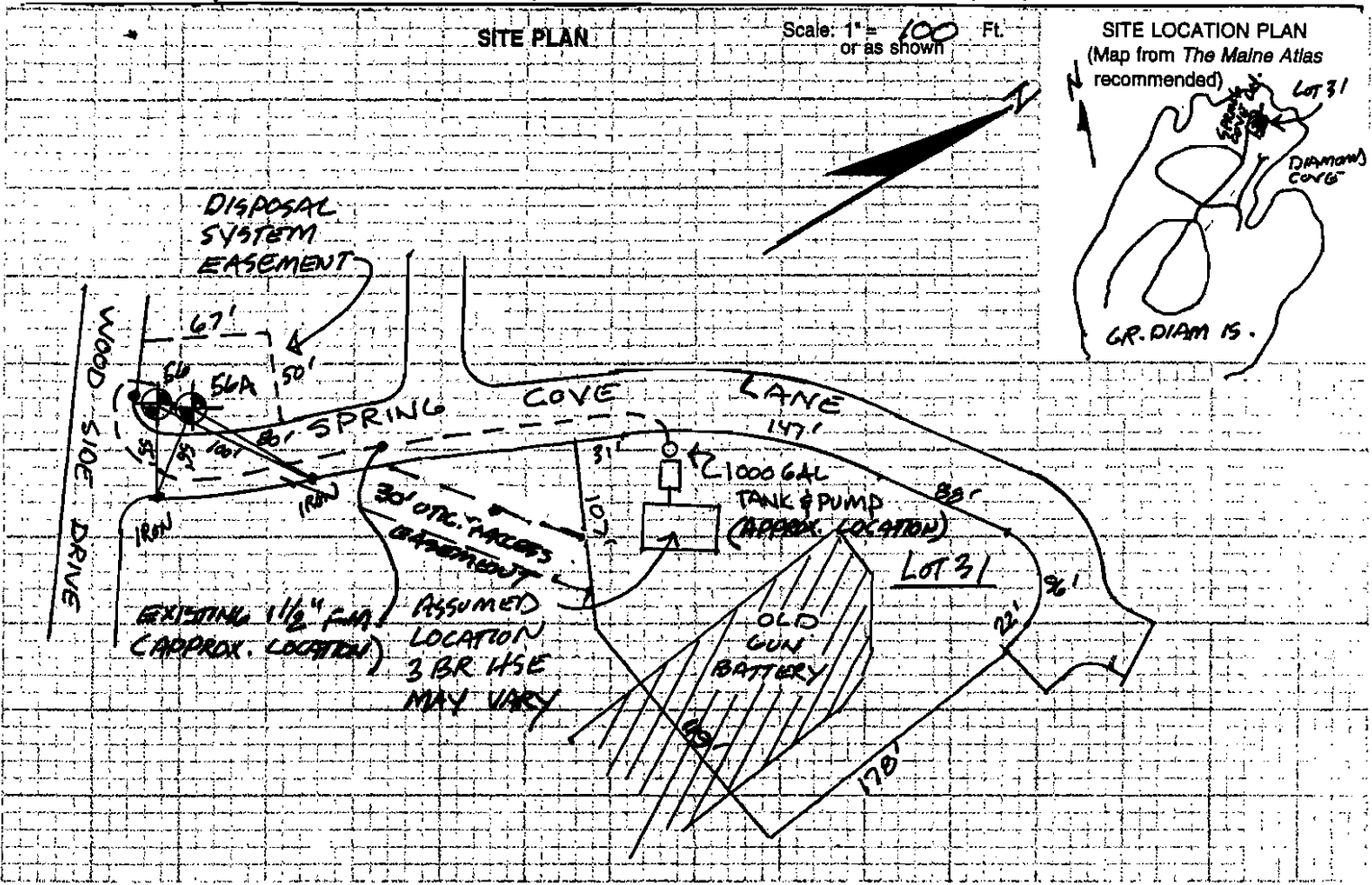

SOIL DESCRIPTION AND CLASSIFICATION

(Location of Observation Holes Shown Above)

Observation Hole 56 Test Pit Boring

2" Depth of Organic Horizon Above Mineral Soil

DEPTH BELOW MINERAL SOIL SURFACE (Inches)	Texture	Consistency	Color	Mottling
0			DARK BROWN	
6	FINE	FRIABLE		
10	SANDY	LOOSE	REDDISH	NOBLE
15	LOAM		BROWN	
20				
25	X X	X	X X	X X
30	BEDROCK			
40				
50				

Soil Profile <u>Z</u>	Class <u>AH/C</u>	Slope <u>7%</u>	Limiting Factor <u>22</u>	<input type="checkbox"/> Ground Water
				<input type="checkbox"/> Restrictive Layer
				<input checked="" type="checkbox"/> Bedrock

Observation Hole 56A Test Pit Boring

2" Depth of Organic Horizon Above Mineral Soil

DEPTH BELOW MINERAL SOIL SURFACE (Inches)	Texture	Consistency	Color	Mottling
0			DARK BROWN	
6	FINE	FRIABLE		
10	SANDY	LOOSE	BROWN	
15	LOAM			
20				
25				
30	X X	X X	X X	X X
35	BEDROCK			
40				
50				

Soil Profile <u>Z</u>	Class <u>AH/C</u>	Slope <u>7%</u>	Limiting Factor <u>20</u>	<input checked="" type="checkbox"/> Ground Water
				<input type="checkbox"/> Restrictive Layer
				<input type="checkbox"/> Bedrock

David A. Kainle
 Site Evaluator Signature

185
 SE #

4/15/05*
 Date

*ORIG. TEST PITS EVALUATED 10/17/84 CONFIRMED 4/15/05

SUBSURFACE WASTEWATER DISPOSAL SYSTEM APPLICATION

Maine Department of Human Services
 Division of Health Engineering, Station 10
 (207) 287-5872 FAX (207) 287-4172

Town, City, Plantation

Street, Road, Subdivision

Owner or Applicant Name

PORTLAND / DIAMOND COVE

SPRING COVE LANE / LOT 31

RYAN RICKER BIE

SUBSURFACE WASTEWATER DISPOSAL PLAN

Scale: 1" = 20' ft.

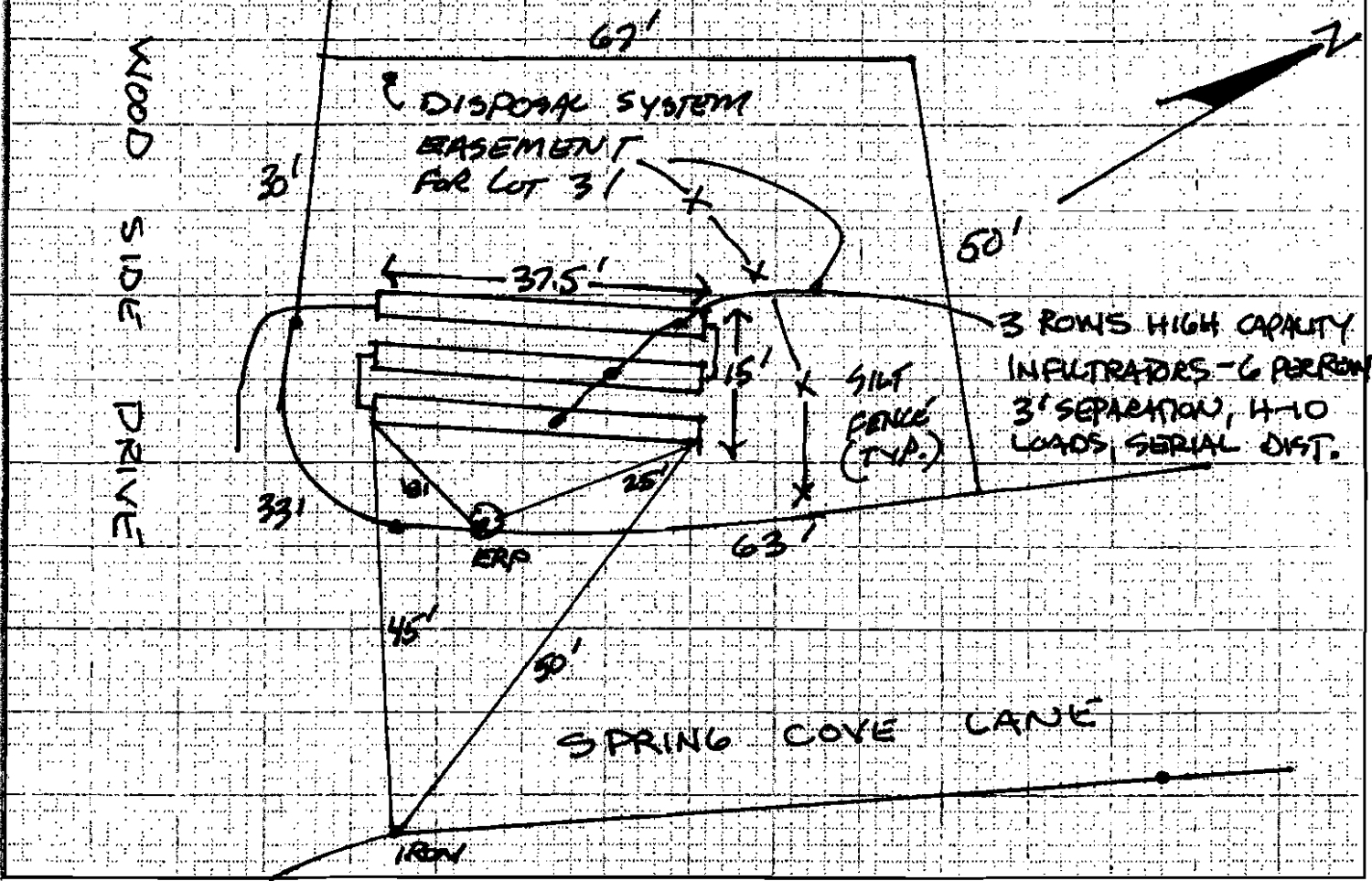

BACKFILL REQUIREMENTS

Depth of Backfill (upslope) 36"
 Depth of Backfill (downslope) 24"
 DEPTHS AT CROSS-SECTION (shown below)

CONSTRUCTION ELEVATIONS

Finished Grade Elevation 585'
 Top of Distribution Pipe or Proprietary Device 581'
 Bottom of Disposal Field 560'

ELEVATION REFERENCE POINT

Location & Description: WOOD NAIL IN 8" BIRCH 54" ABOVE GROUND
 Reference Elevation is: 0.0" or _____

DISPOSAL FIELD CROSS-SECTION

Scales:

Vertical: 1" = 5' ft.
 Horizontal: 1" = 5' ft.

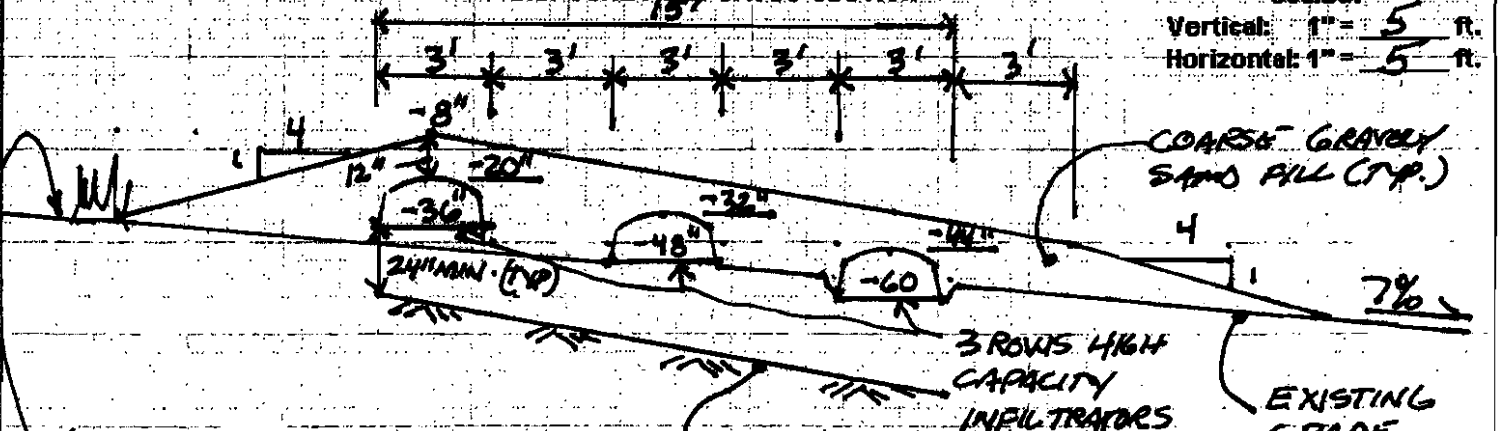

NOTE: LOAM, SEED & MULCH ALL DIST. AREAS (TYP.)

NOTE: REMOVE TREES & ROCKS, ORGANIC MATTER AND SCARIFY BEFORE PLACING FILL

David A. Keil
 Site Evaluator Signature

185
 SE #

4/15/05
 Date

SUBSURFACE WASTEWATER DISPOSAL SYSTEM APPLICATION

Division of Health Engineering, 10 SHS
(207) 287-5872 Fax: (207) 287-3165

PROPERTY LOCATION		>> CAUTION: PERMIT REQUIRED - ATTACH IN SPACE BELOW <<
City, Town, or Plantation	PORTLAND / DIAMOND COVE	2008-6015
Street or Road	SPRING COVE LANE	
Subdivision, Lot #	LOT NO. 31	
OWNER/APPLICANT INFORMATION		The Subsurface Wastewater Disposal System <i>shall not</i> be installed until a Permit is attached HERE by the Local Plumbing Inspector. The Permit shall authorize the owner or installer to install the disposal system in accordance with this application and the Maine Subsurface Wastewater Disposal Rules.
Name (last, first, MI)	RICKARBYE, RYAN <input checked="" type="checkbox"/> Owner <input type="checkbox"/> Applicant	
Mailing Address of Owner/Applicant	3 COUNTRY FARM RD. STRATHAM, N.H. 03885	
Daytime Tel. #	1-603-772-4446	
OWNER OR APPLICANT STATEMENT		CAUTION: INSPECTION REQUIRED
I state and acknowledge that the information submitted is correct to the best of my knowledge and understand that any falsification is reason for the Department and/or Local Plumbing Inspector to deny a Permit.		I have inspected the installation authorized above and found it to be in compliance with the Subsurface Wastewater Disposal Rules Application. (1st) date approved
Signature of Owner or Applicant: <u>William Rickarbye</u> Date: <u>7.7.05</u>		
		Municipal Tax Map # <u>83E-A</u> Lot # <u>31</u>
		Local Plumbing Inspector Signature: _____ (2nd) date approved: _____

PERMIT INFORMATION		
TYPE OF APPLICATION <input checked="" type="checkbox"/> 1. First Time System <input type="checkbox"/> 2. Replacement System Type replaced: _____ Year installed: _____ <input type="checkbox"/> 3. Expanded System <input type="checkbox"/> a. Minor Expansion <input type="checkbox"/> b. Major Expansion <input type="checkbox"/> 4. Experimental System <input type="checkbox"/> 5. Seasonal Conversion	THIS APPLICATION REQUIRES <input checked="" type="checkbox"/> 1. No Rula Variance <input type="checkbox"/> 2. First Time System Variance <input type="checkbox"/> a. Local Plumbing Inspector Approval <input type="checkbox"/> b. State & Local Plumbing Inspector Approval <input type="checkbox"/> 3. Replacement System Variance <input type="checkbox"/> a. Local Plumbing Inspector Approval <input type="checkbox"/> b. State & Local Plumbing Inspector Approval <input type="checkbox"/> 4. Minimum Lot Size Variance <input type="checkbox"/> 5. Seasonal Conversion Permit	DISPOSAL SYSTEM COMPONENTS <input checked="" type="checkbox"/> 1. Complete Non-engineered System <input type="checkbox"/> 2. Primitive System (graywater & alt. toilet) <input type="checkbox"/> 3. Alternative Toilet, specify: _____ <input type="checkbox"/> 4. Non-engineered Disposal Area <input type="checkbox"/> 5. Holding Tank, _____ gallons <input type="checkbox"/> 6. Non-engineered Disposal Field (only) <input type="checkbox"/> 7. Separated Laundry System <input type="checkbox"/> 8. Complete Engineered System (2000 gpd or more) <input type="checkbox"/> 9. Engineered Treatment Tank (only) <input type="checkbox"/> 10. Engineered Disposal Field (only) <input type="checkbox"/> 11. Pre-treatment, specify: _____ <input type="checkbox"/> 12. Miscellaneous Components
SIZE OF PROPERTY 40,743 <input checked="" type="checkbox"/> SQ. FT. <input type="checkbox"/> ACRES	DISPOSAL SYSTEM TO SERVE <input checked="" type="checkbox"/> 1. Single Family Dwelling Unit, No. of Bedrooms: <u>3</u> <input type="checkbox"/> 2. Multiple Family Dwelling, No. of Units: _____ <input type="checkbox"/> 3. Other: _____ (specify) _____ Current Use <input type="checkbox"/> Seasonal <input type="checkbox"/> Year Round <input checked="" type="checkbox"/> Undeveloped	TYPE OF WATER SUPPLY <input type="checkbox"/> 1. Drilled Well <input type="checkbox"/> 2. Dug Well <input type="checkbox"/> 3. Private <input checked="" type="checkbox"/> 4. Public <input type="checkbox"/> 5. Other
SHORELAND ZONING <input checked="" type="checkbox"/> Yes <input type="checkbox"/> No		

DESIGN DETAILS (SYSTEM LAYOUT SHOWN ON PAGE 3)			
TREATMENT TANK <input checked="" type="checkbox"/> 1. Concrete <input checked="" type="checkbox"/> a. Regular <input type="checkbox"/> b. Low Profile <input type="checkbox"/> 2. Plastic <input type="checkbox"/> 3. Other: _____ CAPACITY: <u>1000</u> GAL.	DISPOSAL FIELD TYPE & SIZE <input type="checkbox"/> 1. Stone Bed <input type="checkbox"/> 2. Stone Trench <input checked="" type="checkbox"/> 3. Proprietary Device <input type="checkbox"/> a. cluster array <input checked="" type="checkbox"/> c. Linear <input checked="" type="checkbox"/> b. regular load <input type="checkbox"/> d. H-20 load <input type="checkbox"/> 4. Other: _____ SIZE: <u>900</u> <input type="checkbox"/> sq. ft. <input type="checkbox"/> ln. ft.	GARBAGE DISPOSAL UNIT <input checked="" type="checkbox"/> 1. No <input type="checkbox"/> 2. Yes <input type="checkbox"/> 3. Maybe If Yes or Maybe, specify one below: <input type="checkbox"/> a. multi-compartment tank <input type="checkbox"/> b. _____ tanks in series <input type="checkbox"/> c. increase in tank capacity <input type="checkbox"/> d. Filter on Tank Outlet	DESIGN FLOW <u>270</u> gallons per day BASED ON: <input checked="" type="checkbox"/> 1. Table 501.1 (dwelling unit(s)) <input type="checkbox"/> 2. Table 501.2 (other facilities) SHOW CALCULATIONS --- for other facilities ---
SOIL DATA & DESIGN CLASS PROFILE CONDITION DESIGN <u>2, AIII/C1</u> at Observation Hole # <u>56</u> Depth <u>22'</u> of Most Limiting Soil Factor <u>BEDROCK</u>	DISPOSAL FIELD SIZING <input type="checkbox"/> 1. Small--2.0 sq. ft. / gpd <input type="checkbox"/> 2. Medium--2.6 sq. ft. / gpd <input checked="" type="checkbox"/> 3. Medium--Large 3.3 sq. ft. / gpd <input type="checkbox"/> 4. Large--4.1 sq. ft. / gpd <input type="checkbox"/> 5. Extra Large--5.0 sq. ft. / gpd	EFFLUENT/EJECTOR PUMP <input type="checkbox"/> 1. Not Required <input type="checkbox"/> 2. May Be Required <input checked="" type="checkbox"/> 3. Required Specify only for engineered systems: DOSE: _____ gallons	<input type="checkbox"/> 3. Section 503.0 (meter readings) ATTACH WATER METER DATA

SITE EVALUATOR STATEMENT	
certify that on <u>4/15/05</u> (date) I completed a site evaluation on this property and state that the data reported are accurate and that the proposed system is in compliance with the State of Maine Subsurface Wastewater Disposal Rules (10-144A CMR 241).	
Site Evaluator Signature: <u>David A. Kamila</u>	SE #: <u>185</u> Date: <u>4/15/05</u>
Site Evaluator Name Printed: <u>DAVID A. KAMILA</u>	

Note: Changes to or deviations from the design should be confirmed with the Site Evaluator.

SUBSURFACE WASTEWATER DISPOSAL SYSTEM APPLICATION

Maine Department of Human Services
Division of Health Engineering, Station 10
(207) 287-5872 FAX (207) 287-4172

Town, City, Plantation

Street, Road, Subdivision

Owner or Applicant Name

PORTLAND / DIAMOND COVE

SPRING COVE LANE

RYAN RICKERBIE

SITE PLAN

Scale: 1" = 100 Ft.
or as shown

SITE LOCATION PLAN
(Map from The Maine Atlas recommended)

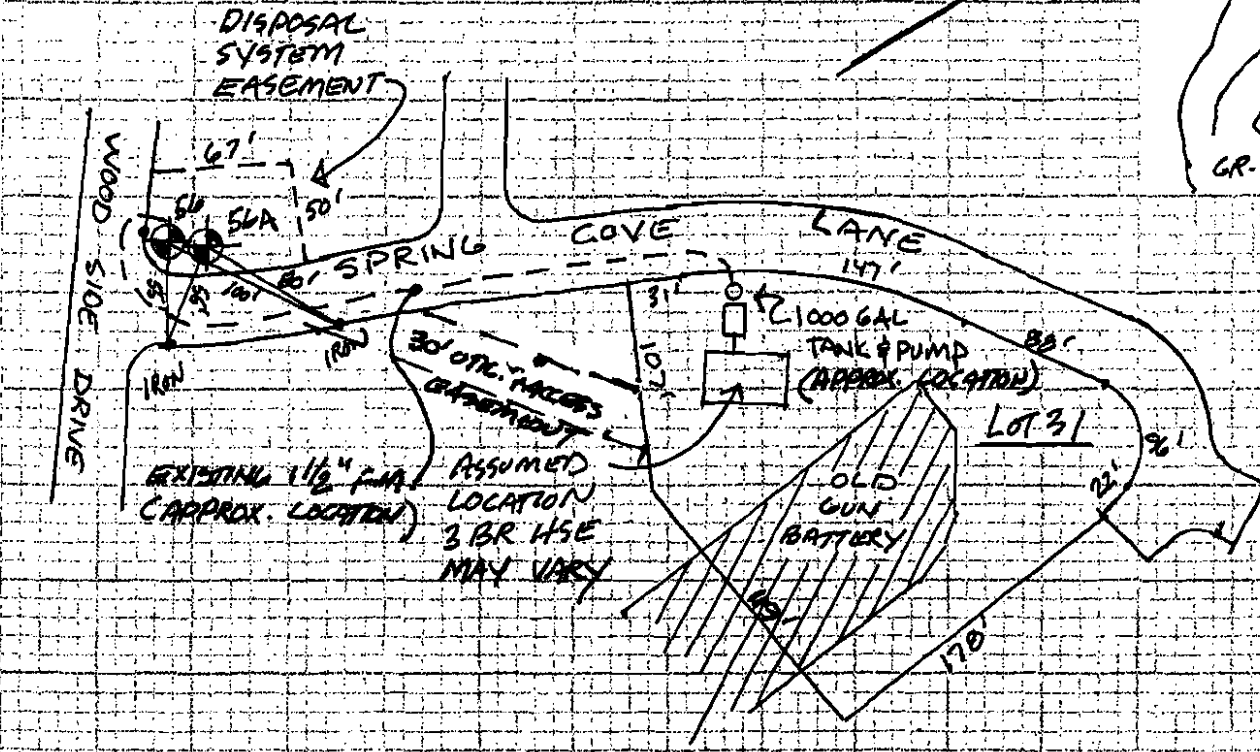
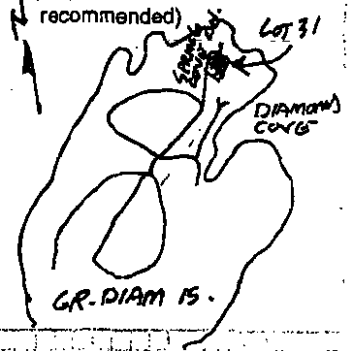

SOIL DESCRIPTION AND CLASSIFICATION

(Location of Observation Holes Shown Above)

Observation Hole 56a Test Pit Boring
2 * Depth of Organic Horizon Above Mineral Soil

DEPTH BELOW MINERAL SOIL SURFACE (inches)	Texture	Consistency	Color	Mottling
0			DARK BROWN	
6	FINE	FRIABLE		
10	SANDY	LOOSE	REDDISH	NOBLE
15	LOAM		BROWN	
20	X X	X X	X X	X X
30	BEDROCK			

Soil Profile	Class	Slope	Limiting Factor	<input type="checkbox"/> Ground Water
Z	AUIC	7%	22.	<input type="checkbox"/> Restrictive Layer
				<input checked="" type="checkbox"/> Bedrock

Observation Hole 56A Test Pit Boring
2 * Depth of Organic Horizon Above Mineral Soil

DEPTH BELOW MINERAL SOIL SURFACE (inches)	Texture	Consistency	Color	Mottling
0			DARK BROWN	
6	FINE	FRIABLE		
10	SANDY	LOOSE	BROWN	
15	LOAM	LOOSE		
20				
30	X X X	X X X	X X X	X X X
36	BEDROCK			

Soil Profile	Class	Slope	Limiting Factor	<input type="checkbox"/> Ground Water
Z	AUIC	7%	20.	<input type="checkbox"/> Restrictive Layer
				<input checked="" type="checkbox"/> Bedrock

David A. Kainle
Site Evaluator Signature

185
SE #

4/15/05*
Date

*ORIG. TEST PITS EVALUATED 10/17/04 CONFIRMED 4/15/05

SUBSURFACE WASTEWATER DISPOSAL SYSTEM APPLICATION

Maine Department of Human Services
 Division of Health Engineering, Station 10
 (207) 287-6872 FAX (207) 287-4172

Town, City, Plantation

Street, Road, Subdivision

Owner or Applicant Name

PORTLAND / DIAMOND COVE

SPRING COVE LANE / LOT 31

RYAN RICKER BUE

SUBSURFACE WASTEWATER DISPOSAL PLAN

Scale: 1" = 20 ft.

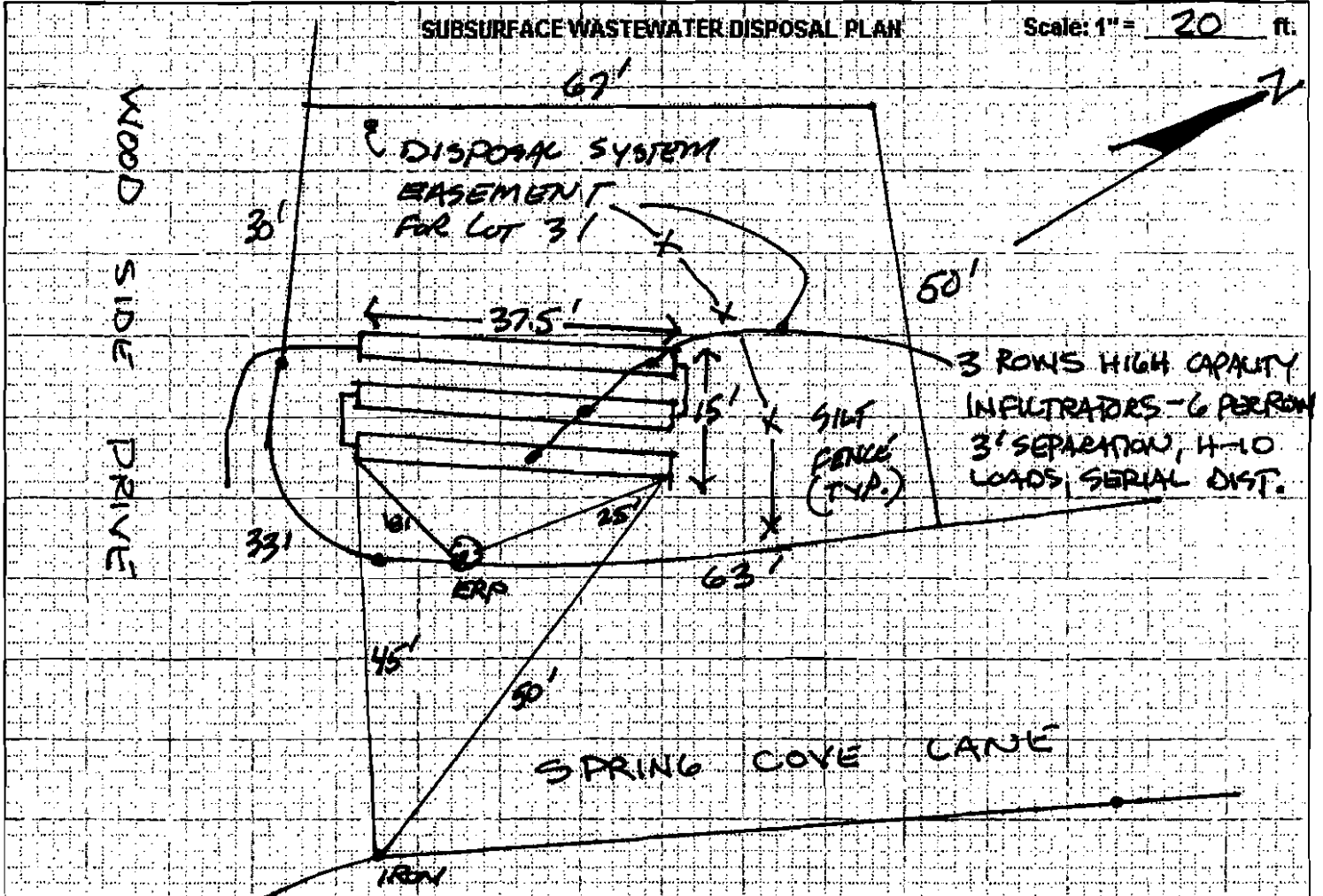

BACKFILL REQUIREMENTS

Depth of Backfill (upslope) 36
 Depth of Backfill (downslope) 24
 DEPTHS AT CROSS-SECTION (shown below)

CONSTRUCTION ELEVATIONS

Finished Grade Elevation SEB
 Top of Distribution Pipe or Proprietary Device SET
 Bottom of Disposal Field BEOW

ELEVATION REFERENCE POINT

Location & Description: HORR NAAC
IN 8" BURCH 54" ABOVE CURB
 Reference Elevation is: 0.0" or

DISPOSAL FIELD CROSS SECTION

Scales:
 Vertical: 1" = 5 ft.
 Horizontal: 1" = 5 ft.

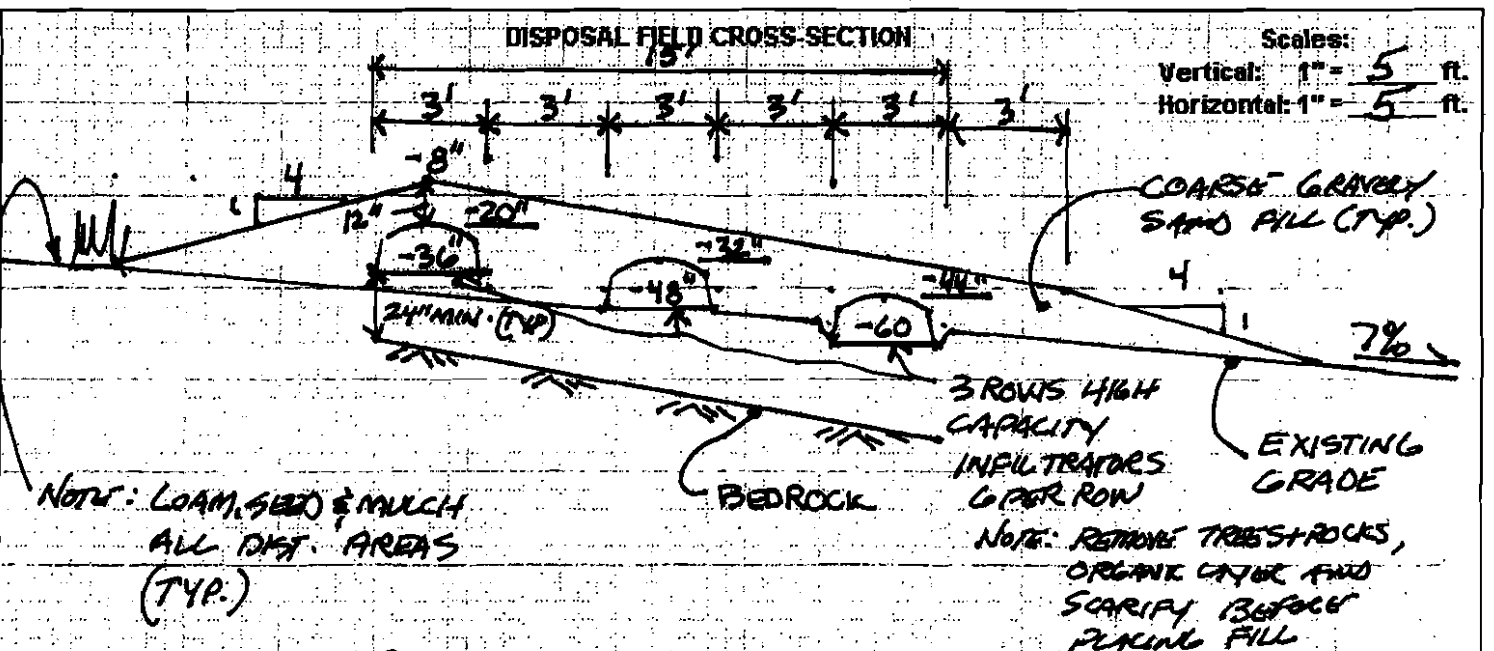

David A. Keir
 Site Evaluator Signature

185
 SE #

4/15/05
 Date

SUBSURFACE WASTEWATER DISPOSAL SYSTEM APPLICATION

Division of Health Engineering, 10 SHS
(207) 287-5872 Fax: (207) 287-3165

PROPERTY LOCATION

>> CAUTION: PERMIT REQUIRED - ATTACH IN SPACE BELOW <<

City, Town, or Plantation: PORTLAND / DIAMOND COVE
 Street or Road: SPRING COVE LANE
 Subdivision, Lot #: LOT NO. 31

2005-6015

OWNER/APPLICANT INFORMATION

Name (last, first, MI): RICKARBYE, RYAN Owner Applicant
 Mailing Address of Owner/Applicant: 3 COUNTRY FARM RD. STRATHAM, N.H. 03885
 Daytime Tel. #: 1-603-772-4446

The Subsurface Wastewater Disposal System *shall not* be installed until a Permit is attached HERE by the Local Plumbing Inspector. The Permit shall authorize the owner or installer to install the disposal system in accordance with this application and the Maine Subsurface Wastewater Disposal Rules.

83EA 31
 Municipal Tax Map # 83EA Lot # 31

OWNER OR APPLICANT STATEMENT

I state and acknowledge that the information submitted is correct to the best of my knowledge and understand that any falsification is reason for the Department and/or Local Plumbing Inspector to deny a Permit.

William Rickarbye 7.7.05
 Signature of Owner or Applicant Date

CAUTION: INSPECTION REQUIRED

I have inspected the installation authorized above and found it to be in compliance with the Subsurface Wastewater Disposal Rules Application.

 Local Plumbing Inspector Signature (1st) date approved

PERMIT INFORMATION

TYPE OF APPLICATION

1. First Time System
 2. Replacement System
 Type replaced: _____
 Year installed: _____

3. Expanded System
 a. Minor Expansion
 b. Major Expansion

4. Experimental System
 5. Seasonal Conversion

THIS APPLICATION REQUIRES

1. No Rule Variance
 2. First Time System Variance
 a. Local Plumbing Inspector Approval
 b. State & Local Plumbing Inspector Approval

3. Replacement System Variance
 a. Local Plumbing Inspector Approval
 b. State & Local Plumbing Inspector Approval

4. Minimum Lot Size Variance
 5. Seasonal Conversion Permit

DISPOSAL SYSTEM COMPONENTS

1. Complete Non-engineered System
 2. Primitive System (graywater & s/t. toilet)
 3. Alternative Toilet, specify: _____
 4. Non-engineered Disposal Area
 5. Holding Tank, _____ gallons
 6. Non-engineered Disposal Field (only)
 7. Separated Laundry System
 8. Complete Engineered System (2000 gpd or more)
 9. Engineered Treatment Tank (only)
 10. Engineered Disposal Field (only)
 11. Pre-treatment, specify: _____
 12. Miscellaneous Components

TYPE OF WATER SUPPLY

1. Drilled Well 2. Dug Well 3. Private
 4. Public 5. Other

SIZE OF PROPERTY

40,743 SQ. FT. ACRES

SHORELAND ZONING

Yes No

DISPOSAL SYSTEM TO SERVE

1. Single Family Dwelling Unit, No. of Bedrooms: 3
 2. Multiple Family Dwelling, No. of Units: _____
 3. Other: _____ (specify)

Current Use Seasonal Year Round Undeveloped

DESIGN DETAILS (SYSTEM LAYOUT SHOWN ON PAGE 3)

TREATMENT TANK

1. Concrete
 a. Regular
 b. Low Profile
 2. Plastic
 3. Other: _____
 CAPACITY: 1000 GAL.

DISPOSAL FIELD TYPE & SIZE

1. Stone Bed 2. Stone Trench
 3. Proprietary Device
 a. cluster array c. Linear
 b. regular load d. H-20 load
 4. Other: _____
 SIZE: 900 sq. ft. lin. ft.

GARBAGE DISPOSAL UNIT

1. No 2. Yes 3. Maybe
 If Yes or Maybe, specify one below:
 a. multi-compartment tank
 b. _____ tanks in series
 c. increase in tank capacity
 d. Filter on Tank Outlet

DESIGN FLOW

270 gallons per day
 BASED ON:
 1. Table 501.1 (dwelling unit(s))
 2. Table 501.2 (other facilities)
 SHOW CALCULATIONS
 — for other facilities —

SOIL DATA & DESIGN CLASS

PROFILE 2 CONDITION AU/C DESIGN 1
 at Observation Hole # 56
 Depth 22
 of Most Limiting Soil Factor BEDROCK

DISPOSAL FIELD SIZING

1. Small—2.0 sq. ft. / gpd
 2. Medium—2.6 sq. ft. / gpd
 3. Medium—Large 3.3 sq. ft. / gpd
 4. Large—4.1 sq. ft. / gpd
 5. Extra Large—5.0 sq. ft. / gpd

EFFLUENT/EJECTOR PUMP

1. Not Required
 2. May Be Required
 3. Required
 Specify only for engineered systems:
 DOSE: _____ gallons

3. Section 503.0 (meter readings)
 ATTACH WATER METER DATA

SITE EVALUATOR STATEMENT

I certify that on 4/15/05 (date) I completed a site evaluation on this property and state that the data reported are accurate and that the proposed system is in compliance with the State of Maine Subsurface Wastewater Disposal Rules (10-144A CMR 241).

David A. Kamila 185 4/15/05
 Site Evaluator Signature SE # Date

DAVID A. KAMILA 878-3313
 Site Evaluator Name Printed

Note: Changes to or deviations from the design should be confirmed with the Site Evaluator.

SUBSURFACE WASTEWATER DISPOSAL SYSTEM APPLICATION

Maine Department of Human Services
 Division of Health Engineering, Station 10
 (207) 287-5872 FAX (207) 287-4172

Town, City, Plantation

Street, Road, Subdivision

Owner or Applicant Name

PORTLAND/DIAMOND COVE

SPRING COVE LANE

RYAN RICKERBIE

SITE PLAN

Scale: 1" = 100 Ft.
 or as shown

SITE LOCATION PLAN
 (Map from The Maine Atlas recommended)

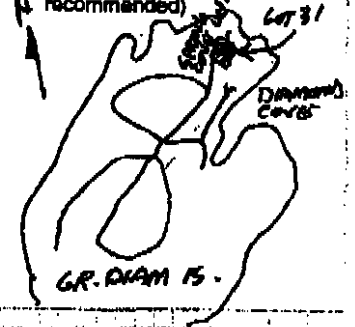

**** NOTE: SEPTIC TANK AND PUMP TANK TO BE LOCATED A MIN. OF 8' FROM FOUNDATION AND 10' FROM PROPERTY LINE.**

DISPOSAL SYSTEM EASEMENT

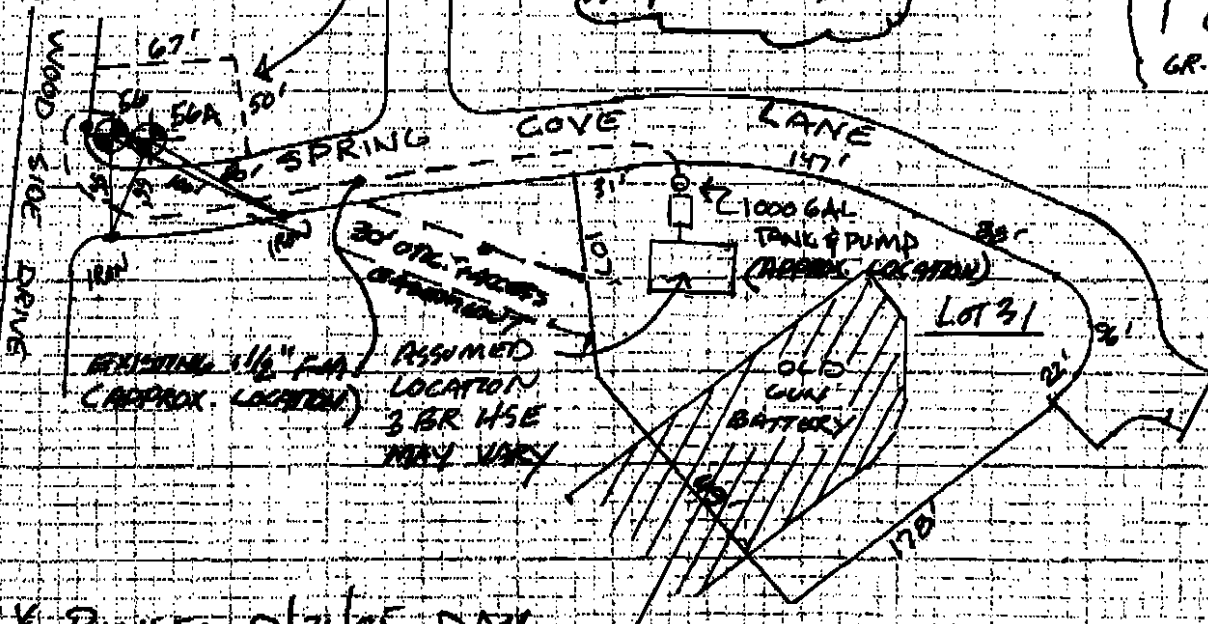

** Reason 9/21/05 DATE

SOIL DESCRIPTION AND CLASSIFICATION

(Location of Observation Holes Shown Above)

Observation Hole 56a Test Pit Boring
2 Depth of Organic Horizon Above Mineral Soil

Texture	Consistency	Color	Mottling
		DARK BROWN	
FINE	FRIBLE		
SANDY	LOOSE	REDDISH	NONE
LOAM		BROWN	
X X X X X X X X			
		BEDROCK	

Soil Profile	Class	Slope	Limiting Factor	<input type="checkbox"/> Ground Water
<u>Z</u>	<u>AWK</u>	<u>7%</u>	<u>22'</u>	<input type="checkbox"/> Restrictive Layer
				<input checked="" type="checkbox"/> Bedrock

Observation Hole 56A Test Pit Boring
2 Depth of Organic Horizon Above Mineral Soil

Texture	Consistency	Color	Mottling
		DARK BROWN	
FINE	FRIBLE		
SANDY	LOOSE	BROWN	
LOAM			
X X X X X X X X			
		BEDROCK	

Soil Profile	Class	Slope	Limiting Factor	<input checked="" type="checkbox"/> Ground Water
<u>Z</u>	<u>AWK</u>	<u>7%</u>	<u>20'</u>	<input type="checkbox"/> Restrictive Layer
				<input type="checkbox"/> Bedrock

David A. Kainle
 Site Evaluator Signature

185
 SE#

4/15/05*
 Date

SUBSURFACE WASTEWATER DISPOSAL SYSTEM APPLICATION

Maine Department of Human Services
Division of Health Engineering, Station 10
(207) 287-5872 FAX (207) 287-4172

Town, City, Plantation

Street, Road, Subdivision

Owner or Applicant Name

PORTLAND / DORRIS COVE

SPRING COVE LANE / LOT 31

RYAN RIKKAR BIE

SUBSURFACE WASTEWATER DISPOSAL PLAN

Scale: 1" = 20' R.

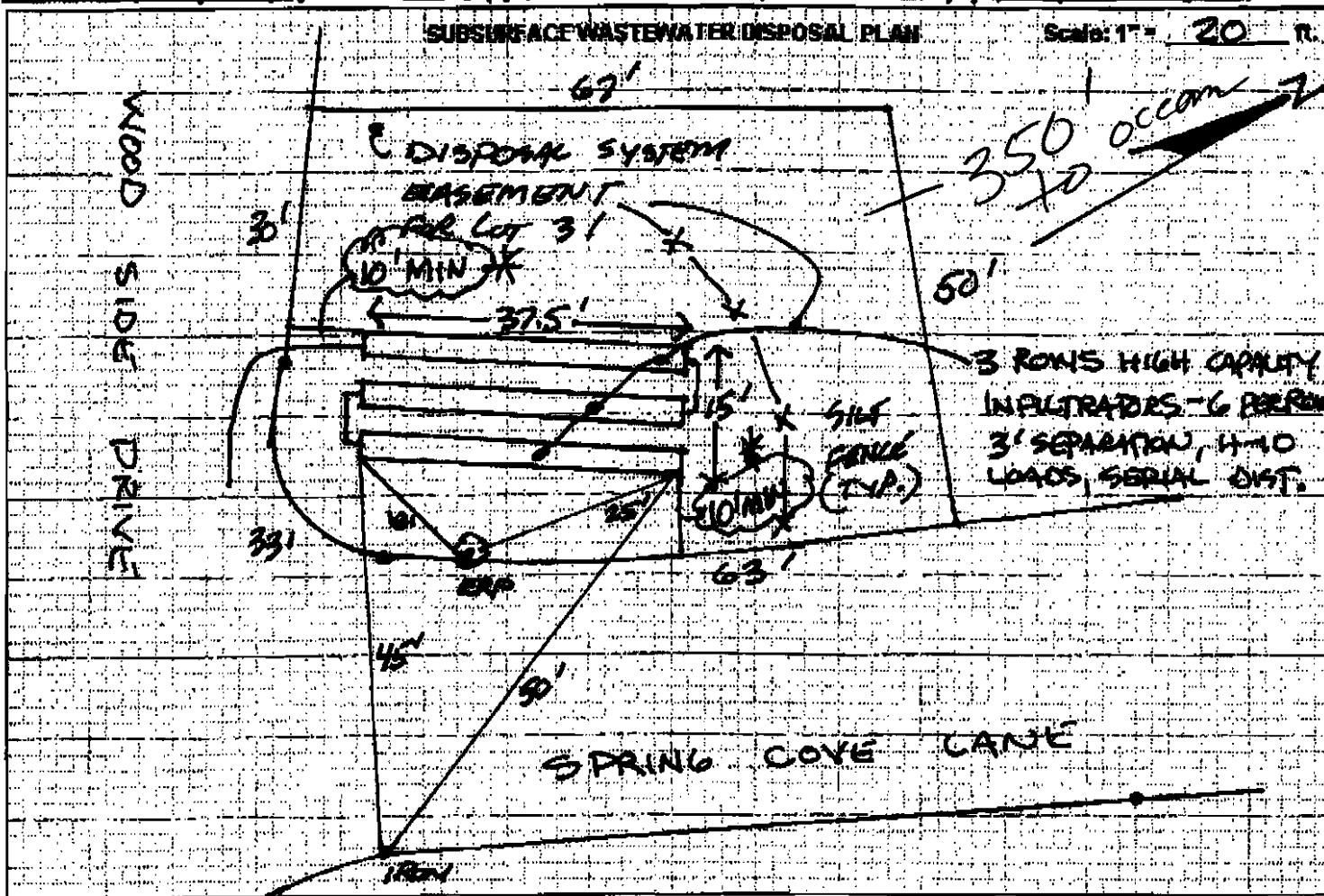

BACKFILL REQUIREMENTS

Depth of Backfill (upslope) 26"
Depth of Backfill (downslope) 24"
DEPTHS AT CROSS-SECTION (shown below)

CONSTRUCTION ELEVATIONS

Finished Grade Elevation 285"
Top of Distribution Pipe or Proprietary Device 281"
Bottom of Disposal Field 260"

ELEVATION REFERENCE POINT

Location & Description: WOOD SIDE
IN 2" BIRCH 5" ABOVE GROUND
Reference Elevation is: 0.0' or _____

DISPOSAL FIELD CROSS SECTION

Scale:
Vertical: 1" = 5' R.
Horizontal: 1" = 5' R.

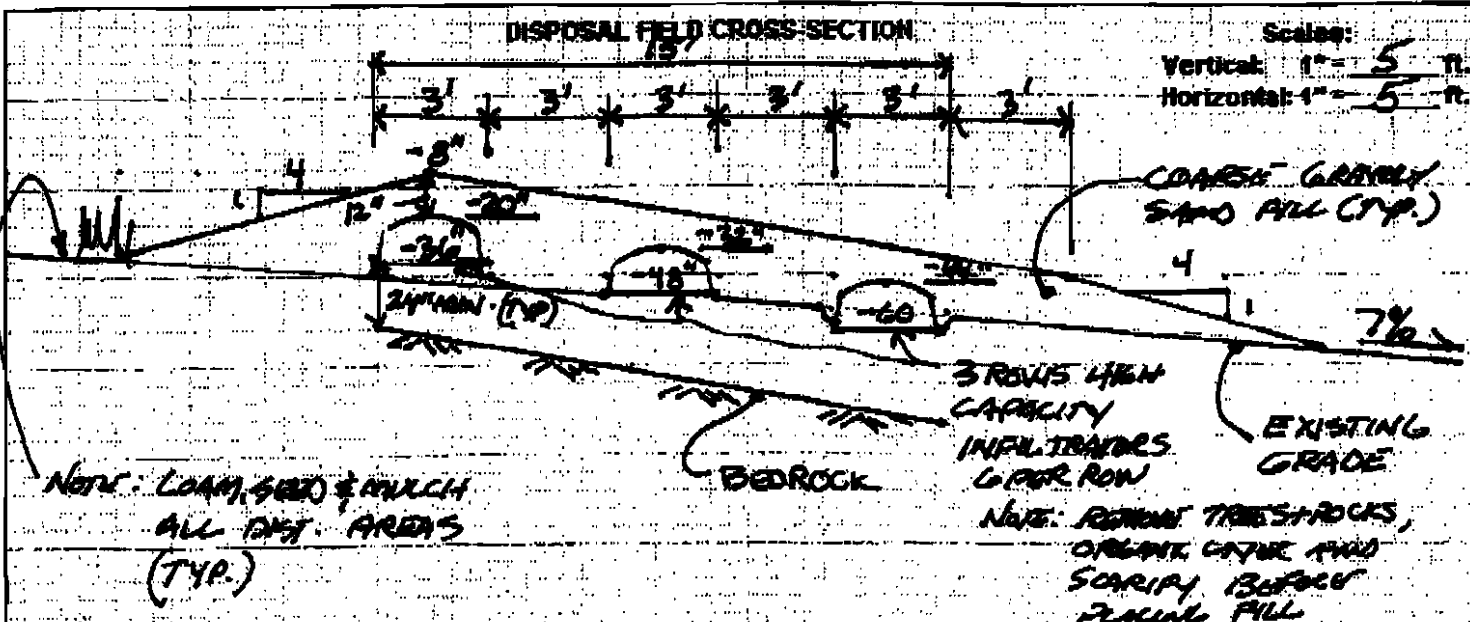

David A. Kiehl
Civil Engineer Registration
SEP. 21 '05 (THU) 11:49

185
4/15/05
Date

SUBSURFACE WASTEWATER DISPOSAL SYSTEM APPLICATION

Maine Department of Human Services
 Division of Health Engineering, Station 10
 (207) 287-5872 FAX (207) 287-4172

Town, City, Plantation

Street, Road, Subdivision

Owner or Applicant Name

PORTLAND / DIAMOND COVE

SPRING COVE LANE

RYAN RICKERBIE

SITE PLAN

Scale: 1" = 100 FL
 or as shown

SITE LOCATION PLAN

(Map from The Maine Atlas recommended)

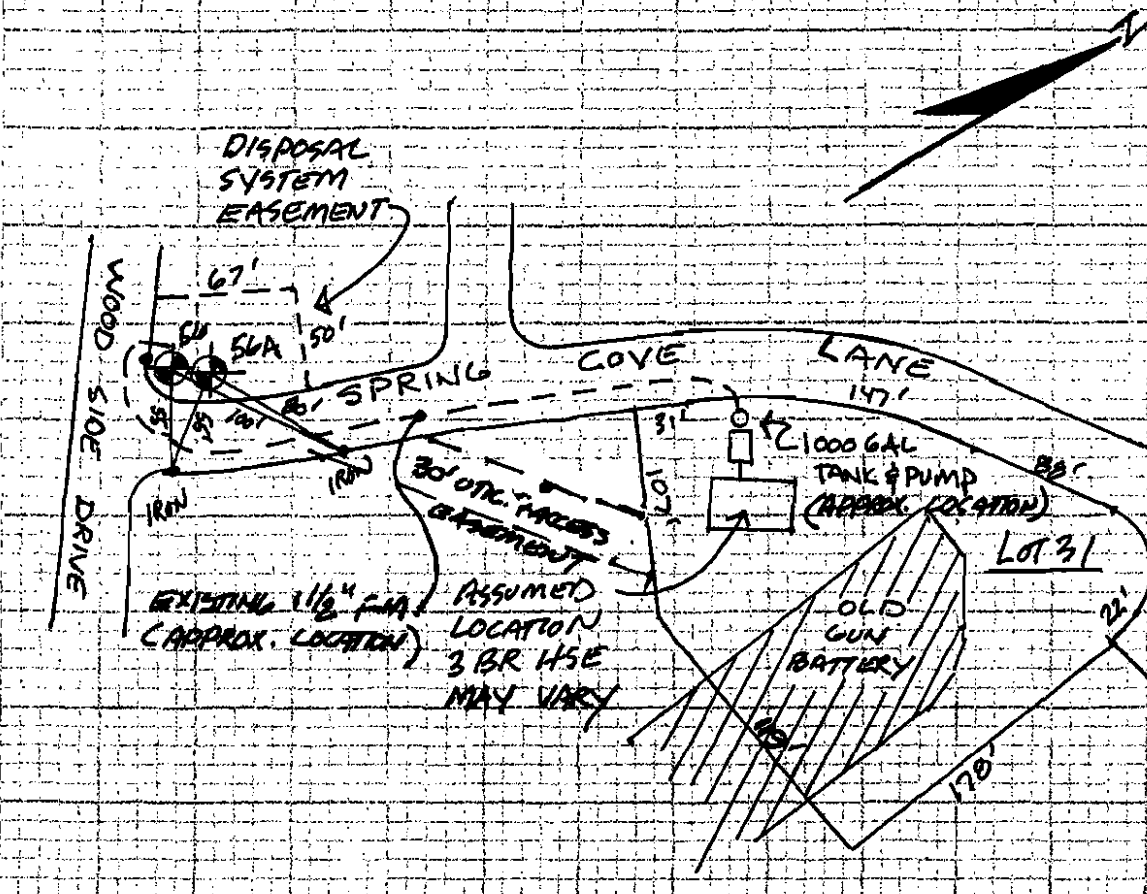
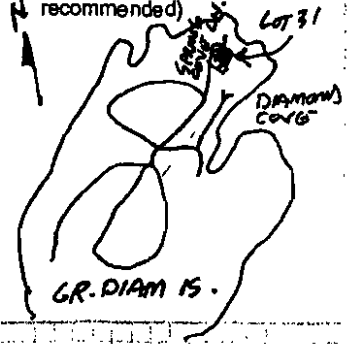

SOIL DESCRIPTION AND CLASSIFICATION

(Location of Observation Holes Shown Above)

Observation Hole 56 Test Pit Boring

2 * Depth of Organic Horizon Above Mineral Soil

DEPTH BELOW MINERAL SOIL SURFACE (Inches)	Texture	Consistency	Color	Mottling
0			DARK BROWN	
6	FINE	FRIABLE		
10	SANDY	LOOSE	REDDISH	NONE
15	LOAM		BROWN	
20	X X	X X	X X	X X
30	BEDROCK			

Soil Profile <u>Z</u>	Class <u>AH/C</u>	Slope <u>7%</u>	Limiting Factor <u>22</u>	<input type="checkbox"/> Ground Water
				<input type="checkbox"/> Restrictive Layer
				<input checked="" type="checkbox"/> Bedrock

Observation Hole 56 A Test Pit Boring

2 * Depth of Organic Horizon Above Mineral Soil

DEPTH BELOW MINERAL SOIL SURFACE (Inches)	Texture	Consistency	Color	Mottling
0			DARK BROWN	
6	FINE	FRIABLE		
10	SANDY	LOOSE	BROWN	
15	LOAM			
20				
30	X X	X X	X X	X X
30	BEDROCK			

Soil Profile <u>Z</u>	Class <u>AH/C</u>	Slope <u>7%</u>	Limiting Factor <u>20</u>	<input type="checkbox"/> Ground Water
				<input type="checkbox"/> Restrictive Layer
				<input type="checkbox"/> Bedrock

David A. Kainle
 Site Evaluator Signature

185
 SE #

4/15/05*
 Date

*ORIG. TEST PITS EVALUATED 10/17/84 CONFIRMED 4/15/05

SUBSURFACE WASTEWATER DISPOSAL SYSTEM APPLICATION

Maine Department of Human Services
Division of Health Engineering, Station 10
(207) 287-5672 FAX (207) 287-4172

Town, City, Plantation

Street, Road, Subdivision

Owner or Applicant Name

PORTLAND/DIAMOND COVE

SPRING COVE LANE / LOT 31

RYAN RICKER BIE

SUBSURFACE WASTEWATER DISPOSAL PLAN

Scale: 1" = 20 ft.

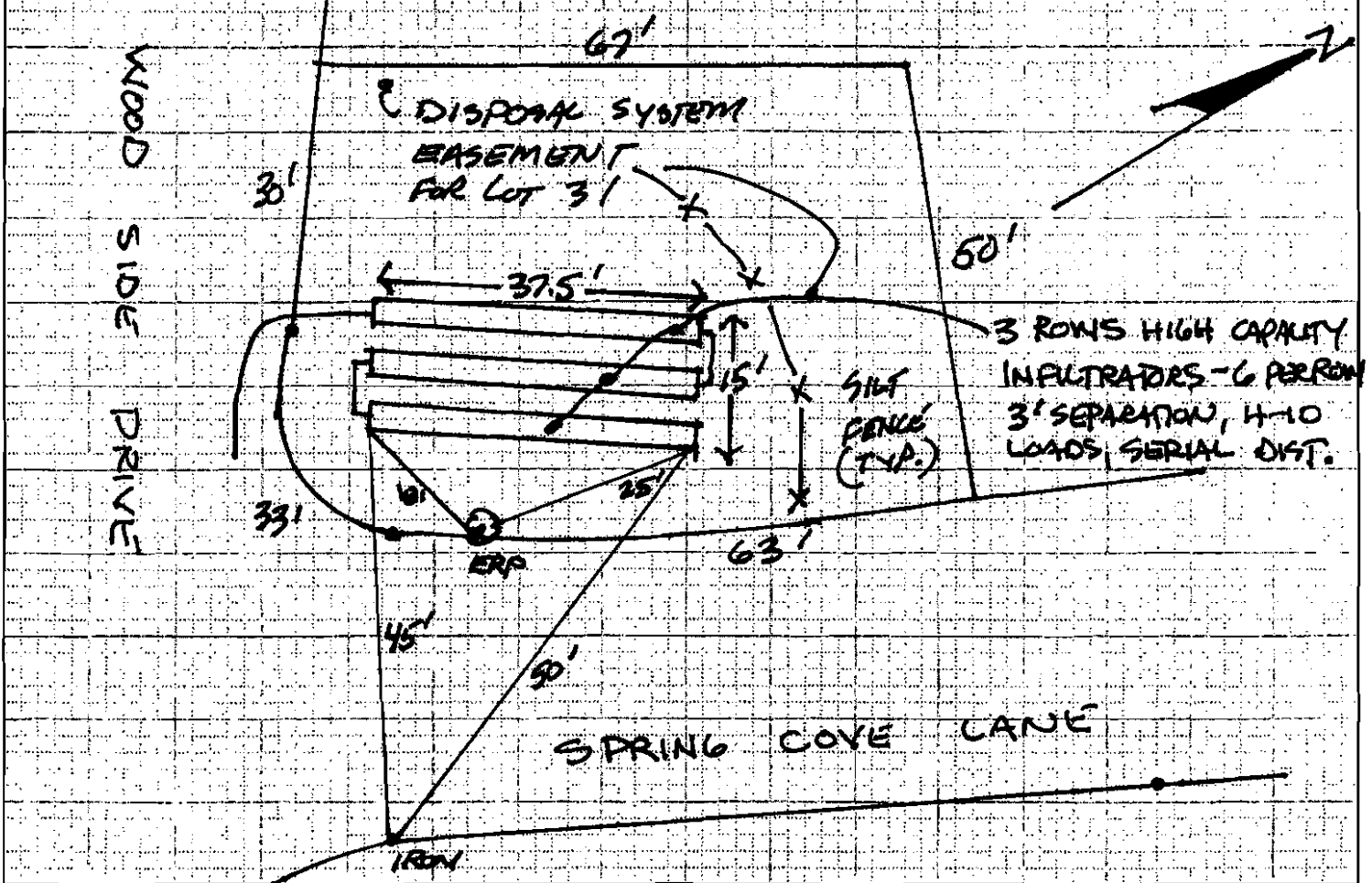

BACKFILL REQUIREMENTS

Depth of Backfill (upslope) 36"

Depth of Backfill (downslope) 24"

DEPTHS AT CROSS-SECTION (shown below)

CONSTRUCTION ELEVATIONS

Finished Grade Elevation 585"

Top of Distribution Pipe or Proprietary Device 581"

Bottom of Disposal Field BELOW

ELEVATION REFERENCE POINT

Location & Description: HOLE MARK IN 8" BIRCH 54" ABOVE GARAGE

Reference Elevation is: 0.0" or: _____

DISPOSAL FIELD CROSS-SECTION

Scales:

Vertical: 1" = 5 ft.

Horizontal: 1" = 5 ft.

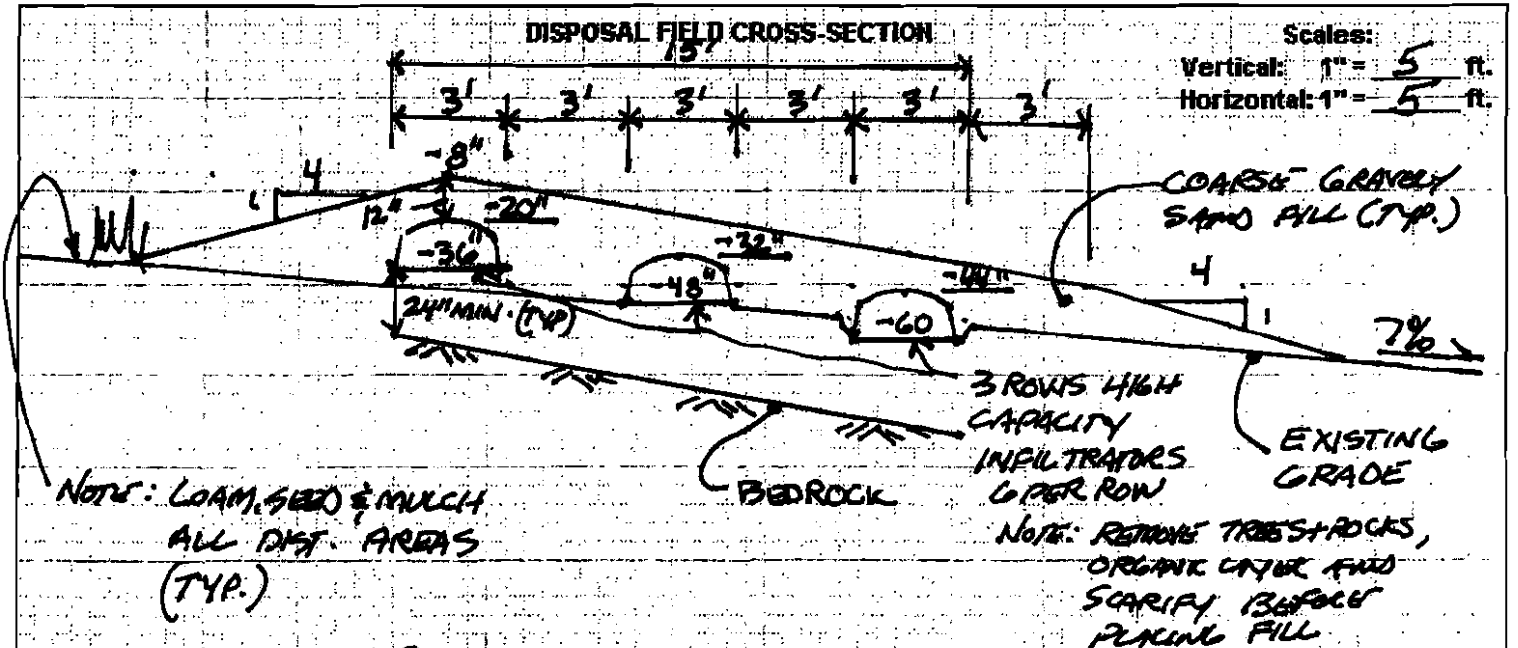

David A. Keirle
Site Evaluator Signature

185
SE #

4/15/05
Date



Land Use Consultants, Inc.

Transmittal

engineers
planners
landscape
architects

To:	Tami Mousan	Date:	9/21/05
From:	David A. Kamila, PE	Job. No.	1420-31
Phone:		Project:	HHE-200
Fax:	874-8716	Pages:	
Re:	REVISIONS	cc:	

Tami -

Per my discussion with KATHY RICKERBIS
THIS MORNING I HAVE ADDED NOTES AND
DIMENSIONS TO THE HHE-200 PLAN FOR
HANG ON DIAMOND COVE AS YOU
REQUESTED.

PLEASE CALL WITH QUESTIONS.

David K.

966 RIVERSIDE STREET
PORTLAND, MAINE 04103

voice (207) 878-3313
fax (207) 878-0907
landuse@landuseinc.net

STAPLES copy printcenter

Complimentary Fax Cover Sheet

To: <i>Mike Nugent Portland Planning Board</i>	From: <i>Cathy Rickaby 603-772-4446 Stratham, NH</i>
Fax # (207) 756-8090	Phone # ()
Date: 9.20.05	<input type="checkbox"/> Urgent <input type="checkbox"/> Confidential <input type="checkbox"/> Confirm Receipt
Number of Pages: (Including Cover) 6	Reply Fax #:
Message: <i>Mike, Hope this is what you're looking for. Thank you for your assistance. Cathy Rickaby</i>	

Staples Copy Centers also offer these additional services:

- High Speed Black & White Copying
- Binding Services
- Custom Printing
- Digital Color Copying
- Laminating
- Custom Checks & Forms
- Convenient Self-Serve Copies
- Custom Stamps
- Personalized Calendars



IMPORTANT

Staples is not responsible for the content of this facsimile. Our customers are cautioned against sending confidential or sensitive personal information via facsimile. Staples is not responsible for misdirected facsimiles. If you received this facsimile in error, please notify the sender at the phone number inserted above for directions concerning the facsimile.

▷ MAP REFERENCE:

- 1) PLAN ENTITLED " SKETCH SHOWING PROPOSED EASEMENTS, DIAMOND COVE PHASE II GREAT DIAMOND ISLAND, PORTLAND, MAINE, " PREPARED FOR MCKINLEY PARTNERS LIMITED PARTNERSHIP, BY LAND USE CONSULTANTS, INC. DATED AUGUST 11, 1995.
- 2) PLAN ENTITLED " AMENDED RECORDING PLAT, DIAMOND COVE PHASE II, SHEET 1 OF 3 GREAT DIAMOND ISLAND, PORTLAND, MAINE, " PREPARED FOR DIAMOND COVE ASSOCIATES, BY LAND USE CONSULTANTS, INC., CCRD PLANBOOK 191 PAGE 143.
- 3) PLAN ENTITLED " UTILITY RECORD DRAWING, DIAMOND COVE PHASE II, WEST SIDE~29 LOTS, SHEET 2 OF 2, " PREPARED FOR MCKINLEY PARTNERS LIMITED PARTNERSHIP, BY LAND USE CONSULTANTS, INC. DATED 06/15/95, THE PLAN IS NOT SEALED AND NOT RECORDED.

GENERAL NOTES

1. THIS PLAN DOES NOT REPRESENT THE RESULTS OF A FIELD SURVEY BY SURVEY AND GEODETIC CONSULTANTS, INC. MONUMENTATION, UTILITIES AND PLANIMETRIC DETAIL SHOWN HEREON IS COMPILED FROM PLANS BY LAND USE CONSULTANTS, INC. (SEE MAP REFERENCES, ABOVE)

2.) THE ARC AT THE REVISED UTILITY EASEMENT BEGINS AT A POINT S 49°19'23" W, 70.00' FROM POINT "A" AND RUNS IN A CLOCKWISE DIRECTION AT A CONSTANT RADIUS OF 11.14' A DISTANCE OF 32.50', INTENDING TO TERMINATE AT THE INTERSECTION OF THE SPRING COVE LANE RIGHT-OF-WAY.

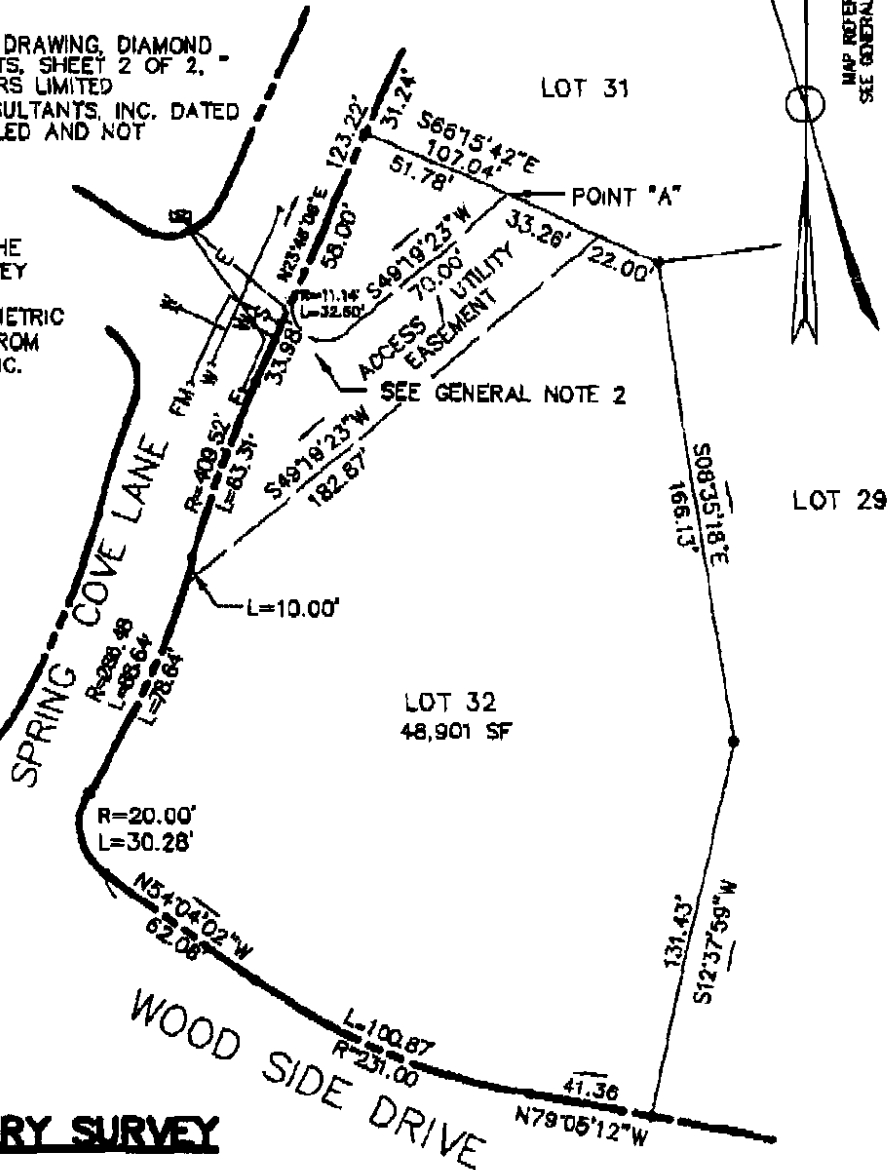

MAP REFERENCE SEE GENERAL NOTE 1.

THIS IS NOT A BOUNDARY SURVEY



12 WESTBROOK COMMONS 2nd FLDOR
WESTBROOK MAINE 04092

Phone: 207-856-0006 Fax: 207-856-0007

PREPARED FOR:

MCKINLEY PARTNERS
LIMITED PARTNERSHIP
GREAT DIAMOND ISLAND
PORTLAND, MAINE
CUMBERLAND COUNTY

SCALE: 1" = 60'

DATE: 11/09/99

LUC JOB #: 1420

SGC JOB #: 1-000032.00

TITLE:

ACCESS / UTILITY
EASEMENT
SKETCH PLAN

Revised 02/23/00

Revised 05/25/00

Warranty Deed

Spiderflies Limited Liability Company, a Connecticut limited liability company, of the Town of Greenwich, County of Fairfield and State of Connecticut, for consideration paid, grants to Ryan Rickarby and Cathleen Rickarby of the Town of Stratham, County of Rockingham and State of New Hampshire, as joint tenants, with WARRANTY COVENANTS the following described premises:

See Attached Exhibit A

Being the same premises conveyed by McKinley Partners Limited Partnership to Spiderflies Limited Liability Company, by Deed dated September 18, 1996, and recorded in the Cumberland County Registry of Deeds in Book 12827, Page 304.

Dated April 1, 2005

Barbara A. Young
Administrative Member,
Spiderflies Limited Liability Company

State of Maine
Cumberland, ss.

April 1, 2005

Personally appeared before me Barbara A. Young, duly authorized signatory of Spiderflies Limited Liability Company, and acknowledged the foregoing instrument to be her free act and deed and the free act and deed of Spiderflies Limited Liability Company.

Before me,



Attorney at Law

JONATHAN L. GOLDBERG
ATTORNEY AT LAW

MAINE REAL ESTATE TAX PAID

Warranty Deed

Spiderflies Limited Liability Company, a Connecticut limited liability company, of the Town of Greenwich, County of Fairfield and State of Connecticut, for consideration paid, grants to Ryan Rickarby and Cathleen Rickarby of the Town of Stratham, County of Rockingham and State of New Hampshire, as joint tenants, with WARRANTY COVENANTS the following described premises:

See Attached Exhibit A

Being the same premises conveyed by McKinley Partners Limited Partnership to Spiderflies Limited Liability Company, by Deed dated September 18, 1996, and recorded in the Cumberland County Registry of Deeds in Book 12827, Page 304.

Dated: April 1, 2005

Barbara A. Young
Administrative Member,
Spiderflies Limited Liability Company

State of Maine
Cumberland, ss.

April 1, 2005

Personally appeared before me Barbara A. Young, duly authorized signatory of Spiderflies Limited Liability Company, and acknowledged the foregoing instrument to be her free act and deed and the free act and deed of Spiderflies Limited Liability Company.

Before me,



Attorney at Law

JONATHAN L. GOLDBERG
ATTORNEY AT LAW

MAINE REAL ESTATE TAX PAID

Schedule A

McKinley Partners Limited Partnership – Spiderflies Limited Liability Company,
Lot 31, Phase II, Great Diamond Island, Portland, Maine

I. Restrictive Covenant

The following restrictive covenant shall apply to, and be binding upon the within described Lot 31, and shall further be a covenant imposed by the Grantor herein upon all subsequent conveyances of single-family house lots on said plan entitled "Amended Recording Plat, Diamond Cove Phase II, Great Diamond Island, Portland, Maine", dated July 9, 1991 and recorded in the Cumberland County Registry of Deeds in Plan Book 191, Pages 143-145 (the "Plan"):

All residences erected on said lot shall contain at least 1,400 square feet of living area as defined in said Amended and Restated General Declaration of Covenants and Restrictions.

The within covenant is imposed for the mutual benefit of the Grantor and the Grantee herein and shall be a continuing covenant running with the land, enforceable by either Grantor or Grantee, their successors, heirs or assigns, or by other owners of lots subject to the same covenant and located on the Plan.

II. Access/Utility Easement

This conveyance of Lot 31 is made together with the benefit of an Access/Utility Easement across Lot 32, for the benefit of Lot 31, as reserved in a Warranty deed from McKinley Partners Limited Partnership to Richard K. Kappelmann and Barbara O. Kappelmann dated August 9, 1995 and recorded in the Cumberland County Registry of Deeds in Book 12069, Page 132.

III. Subsurface Disposal Field Easement

The above-described premises (Lot 31) are also hereby conveyed with the perpetual right and easement to construct and maintain a subsurfaced disposal field, dealing with all pipes and appurtenances thereto, located as follows:

A certain lot or parcel of land lying northwesterly of, and adjacent to, Spring Cove Lane as shown on "Diamond Cove Phase II" dated October 1, 1991 by Land Use Consultants, Inc. recorded in the Cumberland County Registry of Deeds in Plan Book 191 on Page 193 and being more particularly described as follows:

Commencing at a steel rebar set at the most southerly corner of the "Open Space Recreation Area" as shown on said plan at the intersection of said road with Wood Side Drive, said point being the POINT OF BEGINNING.

Exhibit A

A certain lot or parcel of land, together with the buildings and improvements thereon, situated on Great Diamond Island in the City of Portland, County of Cumberland and State of Maine and being Lot No. 31 as shown on a plan entitled "Amended Recording Plat, Diamond Cove Phase II, Great Diamond Island, Portland, Maine, dated July 9, 1991, and recorded in the Cumberland County Registry of Deeds in Plan Book 191, Pages 143 through 145 (the "Plan"), to which Plan and the record thereof reference can be made for a more particular description of the premises; together with the Access/Utility easements and Subsurface Disposal easement described on Schedule A attached hereto and incorporated by reference herein.

The above described premises are conveyed together with and subject to the covenants, conditions, restrictions, rights, easements, charges, liens and other matters set forth or referred to in an Amended and Restated General Declaration of Covenants and Restrictions dated December 23, 1993 and recorded in said Registry of Deeds in Book 11277, Page 322, including Exhibit A thereto (the "Declaration").

For additional covenants affecting the within described premises, see Schedule A attached hereto.

Particular reference is also made to the terms and conditions of State of Maine Department of Environmental Protection Orders dated December 10, 1986 and recorded in said Registry of Deeds in Book 7585, Page 112, dated December 9, 1987 and recorded in said Registry of Deeds in Book 8848, Page 314, dated May 10, 1989 and recorded in said Registry of Deeds in Book 8772, Page 161, dated July 5, 1989 and recorded in said Registry of Deeds in Book 8833, Page 12, re-recorded in said Registry of Deeds in Book 8902, Page 118, dated October 12, 1989 and recorded in said Registry of Deeds in Book 8964, Page 155, dated February 8, 1990 and recorded in said Registry of Deeds in Book 9109, Page 292, and dated June 25, 1991 and recorded in said Registry of Deeds in Book 9641, Page 287.

Being a portion of the premises conveyed to the Grantor by deed of Diamond Cove Associates dated December 17, 1993 and recorded in said Registry of Deeds in Book 11199, Page 237.

Further reference is made to an Assignment of Declarant Rights from Diamond Cove Associates to the Grantor dated December 17, 1993 and recorded in said Registry of Deeds in Book 11199, Page 247.

thence North 54° 04' 02" West along Wood Side Drive a distance of thirty feet (30.00 feet) to a point and remaining Open Space Area;

thence North 27° 28' 33" East along remaining Open Space Area a distance of sixty seven and 93/100 (67.93 feet) to a point;

thence South 72° 46' 40" East along remaining Open Space Area a distance of fifty feet (50.00 feet) to Spring Cove Lane and the point of curvature of a non-tangent curve, concave to the Northwest, having a radius of two hundred fifty one and 48/100 feet (251.48 feet), a central angle of 14° 23' 25", and a chord of sixty three feet (63.00 feet) bearing South 24° 25' 02" West;

thence Southwesterly along said curve, a distance of sixty three and 16/100 feet (63.16 feet) to the point of curvature of a compound curve, concave to the North, having a radius of twenty feet (20.00 feet), a central angle of 94° 19' 14", and a chord of twenty nine and 33/100 feet (29.33 feet) bearing South 78° 46' 20" West;

thence Westerly along said curve, a distance of thirty two and 92/100 feet (32.92 feet) to the POINT OF BEGINNING; said described tract containing 0.09 acre (3,883 square feet), more or less.

Together with the perpetual easement to install, maintain and repair the necessary pipes and utility lines from said Lot 31 in and through Spring Cove Lane to the above-described septic disposal site; provided, however, that Grantee shall restore the surface of Spring Cove Lane to its condition as existed prior to any excavation in said Lane undertaken by Grantee and shall conduct any excavation in a manner which minimizes any interruption to utility services or traffic across said Lane.

The premises are further subject to the following:

1. Release and Abandonment of Access Rights from Spiderflies Limited Liability Company to McKinley Partners Limited Partnership dated May 25, 1999 and recorded in the Cumberland County Registry of Deeds in Book 14807, Page 172.
2. Easement Deed from McKinley Partners Limited Partnership to Spiderflies Limited Liability Company dated June 4, 1999 and recorded in the Cumberland County Registry of Deeds in Book 14807, Page 173.
3. Easement Deed from Richard K. Kappelman and Barbara O. Kappelman to Spiderflies Limited Liability Company dated September 18, 2001 and recorded in the Cumberland County Registry of Deeds in Book 16768, Page 117.

603-772-4446

MAP REFERENCE:

- 1) PLAN ENTITLED " SKETCH SHOWING PROPOSED EASEMENTS, DIAMOND COVE PHASE II GREAT DIAMOND ISLAND, PORTLAND, MAINE, PREPARED FOR MCKINLEY PARTNERS LIMITED PARTNERSHIP, BY LAND USE CONSULTANTS, INC. DATED AUGUST 11, 1995.
- 2) PLAN ENTITLED " AMENDED RECORDING PLAT, DIAMOND COVE PHASE II, SHEET 1 OF 3 GREAT DIAMOND ISLAND, PORTLAND, MAINE, PREPARED FOR DIAMOND COVE ASSOCIATES, BY LAND USE CONSULTANTS, INC., CCRD PLANBOOK 191 PAGE 143.
- 3) PLAN ENTITLED " UTILITY RECORD DRAWING, DIAMOND COVE PHASE II, WEST SIDE~29 LOTS, SHEET 2 OF 2, " PREPARED FOR MCKINLEY PARTNERS LIMITED PARTNERSHIP, BY LAND USE CONSULTANTS, INC. DATED 06/15/95, THE PLAN IS NOT SEALED AND NOT RECORDED.

GENERAL NOTES

1. THIS PLAN DOES NOT REPRESENT THE RESULTS OF A FIELD SURVEY BY SURVEY AND GEODETIC CONSULTANTS, INC. MONUMENTATION, UTILITIES AND PLANIMETRIC DETAIL SHOWN HEREON IS COMPILED FROM PLANS BY LAND USE CONSULTANTS, INC. (SEE MAP REFERENCES, ABOVE)

2.) THE ARC AT THE REVISED UTILITY EASEMENT BEGINS AT A POINT S 49°19'23" W, 70.00' FROM POINT "A" AND RUNS IN A CLOCKWISE DIRECTION AT A CONSTANT RADIUS OF 11.14' A DISTANCE OF 32.50', INTENDING TO TERMINATE AT THE INTERSECTION OF THE SPRING COVE LANE RIGHT-OF-WAY.

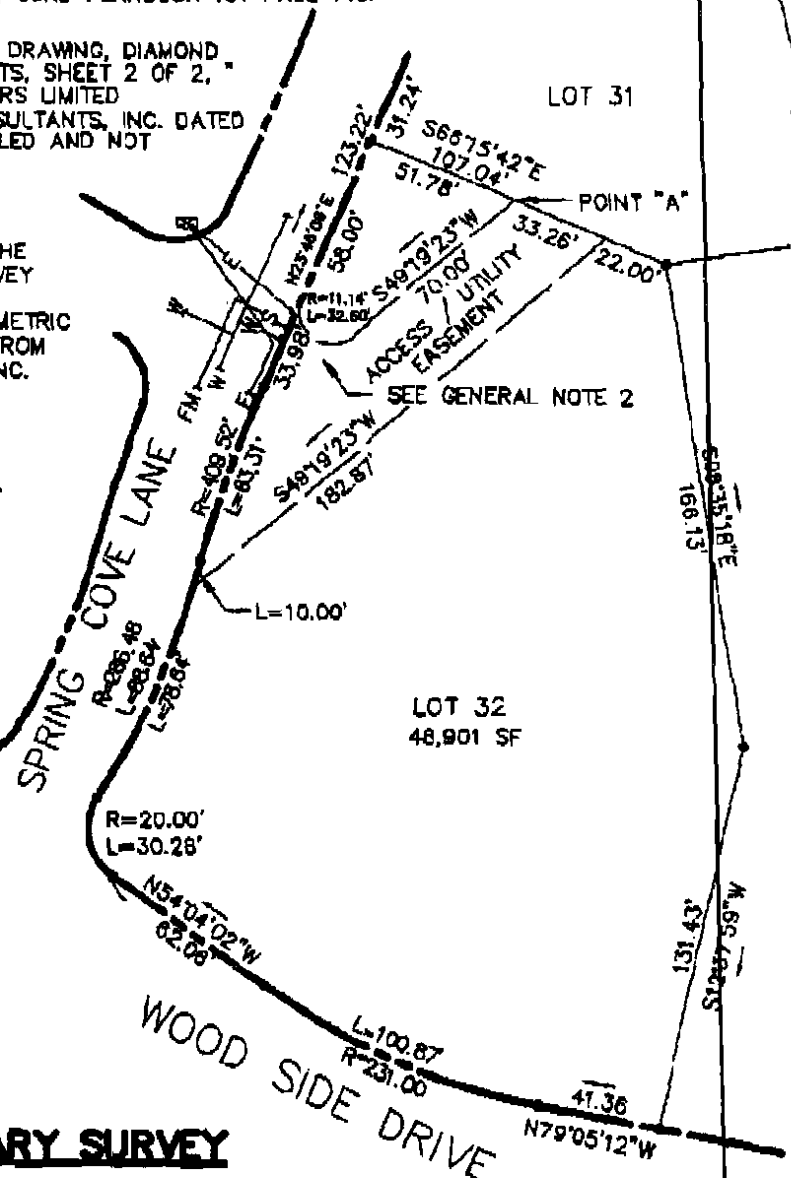

MAP REFERENCE
SEE GENERAL NOTE 1.

THIS IS NOT A BOUNDARY SURVEY



12 WESTBROOK COMMONS 2nd FLOOR
WESTBROOK MAINE 04092
Phone: 207-856-0006 Fax: 207-856-0007

PREPARED FOR:

MCKINLEY PARTNERS
LIMITED PARTNERSHIP
GREAT DIAMOND ISLAND
PORTLAND, MAINE
CUMBERLAND COUNTY
SCALE: 1" = 60'
DATE: 11/09/99
LUC JOB #: 1420
SGC JOB #: 1-000032.00

TITLE:

ACCESS / UTILITY
EASEMENT
SKETCH PLAN
Revised 02/23/00
Revised 05/25/00

STAPLES copy printcenter

Complimentary Fax Cover Sheet

To: <i>Mike Nugent Portland Planning Board</i>	From: <i>Cathy Rickarby 603-772-4446 Stratham, NH</i>
Fax # (207) 756-8090	Phone # ()
Date: <i>9.20.05</i>	<input type="checkbox"/> Urgent <input type="checkbox"/> Confidential <input type="checkbox"/> Confirm Receipt
Number of Pages: (Including Cover) <i>6</i>	Reply Fax #:

Message:
*Mike, Hope this is what
You're looking for. Thank you
for your assistance.*
RODNEY COLEMAN Cathy Rickarby

Staples Copy Centers also offer these additional services:

- High Speed Black & White Copying
- Binding Services
- Custom Printing
- Digital Color Copying
- Laminating
- Custom Checks & Forms
- Convenient Self-Serve Copies
- Custom Stamps
- Personalized Calendars



IMPORTANT

Staples is not responsible for the content of this facsimile. Our customers are cautioned against sending confidential or sensitive personal information via facsimile. Staples is not responsible for misdirected facsimiles. If you received this facsimile in error, please notify the sender at the phone number inserted above for directions concerning the facsimile.

JOHN DIETZ - 766-5153

BONNIE-

7.5 Extent of Members' Easements: The rights and easements of enjoyment created hereby shall be subject to the following:

7.5.1 Rights of Declarant, its successors and assigns, as herein reserved.

7.5.2 Rights of the Association which is the grantee of common properties, including, but not limited to the right of the Association to charge reasonable admission and other fees for the use of the common properties or to suspend the enjoyment rights of any member by reason of unpaid assessments or violations hereof or of Rules and Regulations, all as provided herein.

7.6 Rights Reserved by the Declarant: Declarant, for itself, its successors and assigns, reserves for the benefit of Declarant or any properties of Declarant or any successor or assign of Declarant, which need not include the properties, the following rights in any of the properties transferred to the Association or the owners:

7.6.1 Unless expressly waived by Declarant, Declarant reserves exclusively unto itself, its successors and assigns, a perpetual, alienable and releasable utility easement and right in, on, over and under the properties to erect, maintain, operate and use poles, wires, cables, switches, computers, receptacles, satellite transmission earth stations, conduits, directional and informational signs, drainage ways, sewers, irrigation lines, wells, antennas, receivers, garbage collection facilities, pumping stations, tanks, water mains and other suitable equipment including microwave and satellite stations for the conveyance, transmission or use of video, voice, facsimile and data communications, electricity, gas, sewer, water, drainage or other public convenience, utilities and communication facilities on, in or through those portions of the properties as may be reasonably required for utility line purposes; provided, however, that:

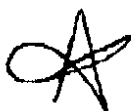
- 
- (a) no utility easement shall run across any portion of the properties which is covered by an existing building or across any area for which written approvals to construct a building thereon have been obtained within the past year from Declarant;
 - (b) such easement or installation of utilities therein or thereon shall be maintained in as attractive a state as is reasonably feasible;
 - (c) Declarant, without obligation, reserves the right to transfer any such utilities and easements, in whole or in part, which it owns to the Association, at which time the Association shall

be responsible for and shall have the obligations to operate and maintain such utility easements;

- (d) Declarant, without obligation, reserves the right to transfer such utilities and utility easements and easements of access to such utility and utility easements, in whole or in part, to another entity, whether public or private, which shall undertake to provide such utility service.

No utility, communications, public convenience or transportation facility described in this Article 7 may be installed or operated unless such facility is approved by Declarant. Declarant or service providers approved by Declarant may charge reasonable fees for the provision of such utility, communications, public convenience or transportation facilities or services.

These easements and rights expressly include the right to cut any trees, bushes or shrubbery, make any gradings of the soil or take any other similar action reasonably necessary to provide economical and safe utility installation and to maintain reasonable standards of health, safety and appearance, except that no such easements and rights may be exercised in violation of Section 4.13 of this Declaration or the Design Guidelines. Any material disturbance to the grounds of any owner or common properties caused by such utility installation shall be repaired and said grounds returned to a reasonable reconstruction of their prior condition by Declarant or prompt and reasonable remuneration for such repair shall be made to such owner or association of owners by Declarant. Declarant further reserves to itself, its successors and assigns, the right to locate the waterlines, pumping stations, siltation basins and tanks within the common properties, or on any lot with the permission of the owner thereof.

7.6.2 An easement is reserved for surface drainage in and along the streets and such other locations as are shown on the Phase I and Phase II Plans as "drainage easement" or otherwise designated for such intended purpose.

7.6.3 An easement is reserved for the purposes stated in Section 7.6.1 with respect to areas within platted streets and roadways. Declarant, its successors, assigns, employees and licensees, shall have the unobstructed use at all times of all streets and roadways.

7.6.4 The right to construct and maintain on the common properties, paths and trails for recreational use by owners or Declarant, provided such paths and trails shall be constructed so as not to adversely affect the scenic character of the common properties.



PORTLAND MAINE

Planning Division

Jay Reynolds, Development Review Coordinator

Zoning + Code:

Revised / Approved site
plan for 27 Spring Cove Dr.,
CBLO83E031.

GENERAL NOTES:

- 1) THIS PLAN AND ALL WORK ASSOCIATED WITH IT WAS PERFORMED BY SGC ENGINEERING, LLC PURSUANT TO A PROFESSIONAL SERVICES CONTRACT BETWEEN RYAN RICKARBY AND SGC ENGINEERING LLC, DATED APRIL 13, 2005.
- 2) REFERENCE DEED FOR THE LOCUS PARCEL IS SPIDERFLIES LIMITED LIABILITY COMPANY TO RYAN AND CATHLEEN RICKARBY DATED APRIL 1, 2005 AND RECORDED IN DEED BOOK 22483, PAGE 66 RECORDED AT THE CUMBERLAND COUNTY REGISTRY OF DEEDS.
- 3) THE LOCUS PARCEL IS DEPICTED AS LOT 31 ON PORTLAND ASSESSORS MAP 83-E.
- 4) NO SUBSURFACE INVESTIGATION HAS BEEN PERFORMED BY SGC ENGINEERING, LLC. DISE-SAFE SHOULD BE CONTACTED PRIOR TO COMMENCING ANY EXCAVATION. (888-344-7233).
- 5) THIS PLAN IS THE RESULT OF A FIELD SURVEY CONDUCTED BY SGC ENGINEERING, LLC ON APRIL 18, 2005.
- 6) BEARINGS AND NORTH ARROW ORIENTATION AS SHOWN HEREON ARE BASED ON MAP REFERENCES.

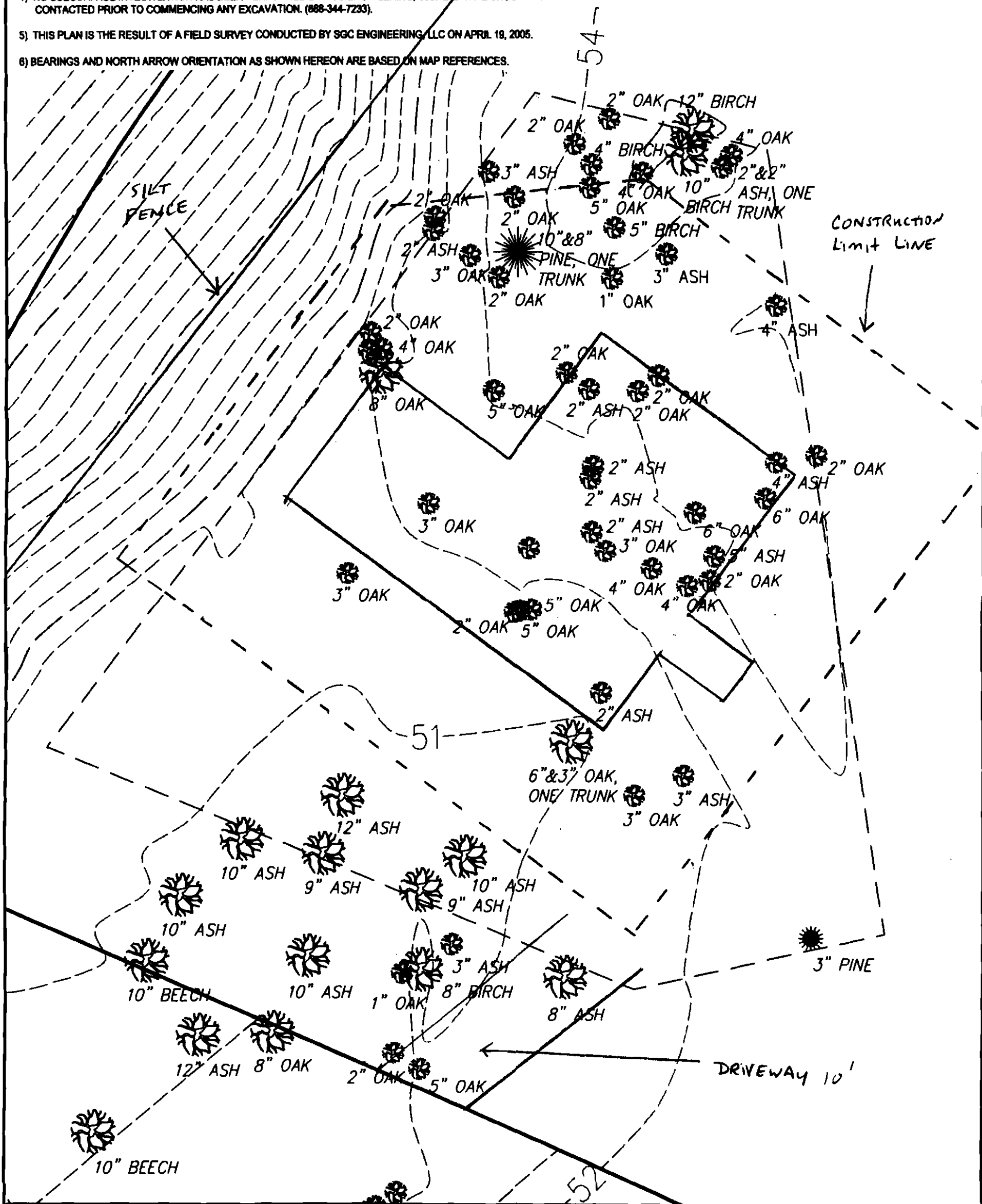

SKETCH PLAN OF PROPERTY LOCATED ON
SPRING COVE LANE
GREAT DIAMOND ISLAND
PORTLAND, MAINE

PREPARED FOR
RYAN RICKARBY

3 COUNTRY FARM ROAD, STRATHAM, NH, 03885



SGC ENGINEERING, LLC

- Civil Design & Survey Engineering
- Environmental & Regulatory Permitting
- Electrical Power Systems Engineering

SERVING OUR CLIENTS IN THE U.S.A. & CANADA

501 County Road
 Westbrook, Maine 04092
 P.O. Box 470 Westbrook, 04098
 Tel: 207-347-8100
 Fax: 207-347-8101

Target Technology Center
 20 Godfrey Drive, Suite 200
 Orono, Maine 04473
 Tel: 207-888-8871
 Fax: 207-888-8881

SHEET 2 OF 2

DATE: 05/03/05 SCALE: 1" = 10' DRAWN: CWM/CRM FILE: EXH_281004

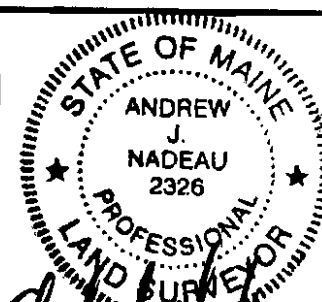

Andrew J. Nadeau

GENERAL NOTES:

- 1) THIS PLAN AND ALL WORK ASSOCIATED WITH IT WAS PERFORMED BY SGC ENGINEERING, LLC PURSUANT TO A PROFESSIONAL SERVICES CONTRACT BETWEEN RYAN RICKARBY AND SGC ENGINEERING LLC, DATED APRIL 13, 2005.
- 2) REFERENCE DEED FOR THE LOCUS PARCEL IS SPIDERFLIES LIMITED LIABILITY COMPANY TO RYAN AND CATHLEEN RICKARBY DATED APRIL 1, 2005 AND RECORDED IN DEED BOOK 22483, PAGE 68 RECORDED AT THE CUMBERLAND COUNTY REGISTRY OF DEEDS.
- 3) THE LOCUS PARCEL IS DEPICTED AS LOT 31 ON PORTLAND ASSESSORS MAP 83-E.
- 4) NO SUBSURFACE INVESTIGATION HAS BEEN PERFORMED BY SGC ENGINEERING, LLC. DIG-SAFE SHOULD BE CONTACTED PRIOR TO COMMENCING ANY EXCAVATION. (888-344-7233).
- 5) THIS PLAN IS THE RESULT OF A FIELD SURVEY CONDUCTED BY SGC ENGINEERING, LLC ON APRIL 19, 2005.
- 6) BEARINGS AND NORTH ARROW ORIENTATION AS SHOWN HEREON ARE BASED ON MAP REFERENCES.

DIAMOND COVE PHASE II
LOT 23

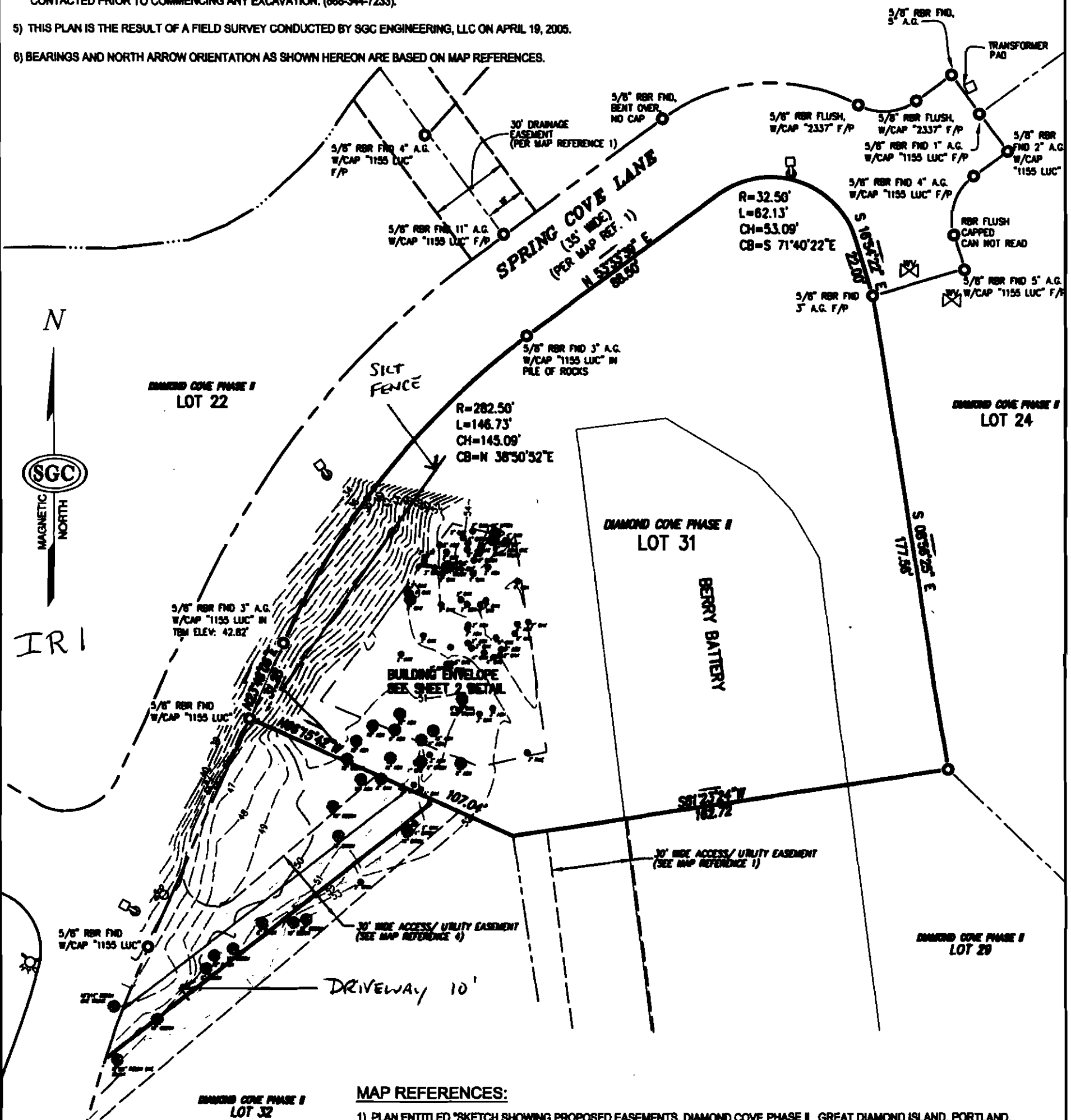

MAP REFERENCES:

- 1) PLAN ENTITLED "SKETCH SHOWING PROPOSED EASEMENTS, DIAMOND COVE PHASE II GREAT DIAMOND ISLAND, PORTLAND, MAINE" PREPARED FOR MCKINLEY PARTNERS LIMITED PARTNERSHIP, BY LAND USE CONSULTANTS, INC. DATED AUGUST 11, 1995.
- 2) PLAN ENTITLED "AMENDED RECORDING PLAT DIAMOND COVE PHASE II, SHEET 1 OF 3 GREAT DIAMOND ISLAND, PORTLAND, MAINE" PREPARED FOR DIAMOND COVE ASSOCIATES BY LAND USE CONSULTANTS, INC. CCRD PLAN BOOK 191 PAGE 143.
- 3) PLAN ENTITLED "UTILITY RECORD DRAWING, DIAMOND COVE PHASE II, WEST SIDE-29 LOTS, SHEET 2 OF 2 PREPARED FOR MCKINLEY PARTNERS LIMITED PARTNERSHIP, BY LAND USE CONSULTANTS, INC. DATED JUNE 15, 1995, THE PLAN IS NOT SEALED AND NOT RECORDED.
- 4) PLAN ENTITLED "ACCESS / UTILITY EASEMENT SKETCH PLAN, PREPARED FOR MCKINLEY PARTNERS LIMITED PARTNERSHIP, GREAT DIAMOND ISLAND, PORTLAND, MAINE" BY SGC ENGINEERING, LLC. DATED NOVEMBER 9, 1999.

LEGEND:

- IRON PIPE OR ROD --- ○
- LAMP POST --- □
- WATER SHUT OFF --- ⊕
- FIRE HYDRANT --- ⊕
- WATER VALVE --- ⊕

SKETCH PLAN OF PROPERTY LOCATED ON
SPRING COVE LANE
GREAT DIAMOND ISLAND
PORTLAND, MAINE
PREPARED FOR
RYAN RICKARBY

3 COUNTRY FARM ROAD, STRATHAM, NH, 03885



SGC ENGINEERING, LLC

- Civil Design & Survey Engineering
- Environmental & Regulatory Permitting
- Electrical Power Systems Engineering

SERVING OUR CLIENTS IN THE U.S.A. & CANADA

801 County Road
Westbrook, Maine 04091
P.O. Box 470 Westbrook, 04091
Tel: 207-347-9100
Fax: 207-347-9191

Target Technology Center
20 Godfrey Drive, Suite 200
Owens, Maine 04473
Tel: 207-688-0871
Fax: 207-688-0801

SHEET 1 OF 2

DATE: 05/03/05 SCALE: 1" = 40' DRAWN: CWM/CRM FILE: EXH_281004

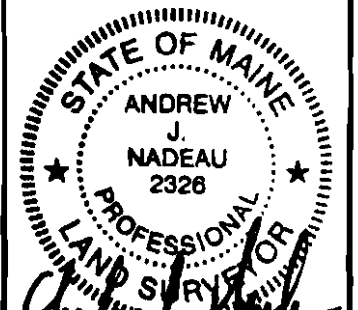

GENERAL NOTES:

- 1) THIS PLAN AND ALL WORK ASSOCIATED WITH IT WAS PERFORMED BY SGC ENGINEERING, LLC PURSUANT TO A PROFESSIONAL SERVICES CONTRACT BETWEEN RYAN RICKARBY AND SGC ENGINEERING LLC, DATED APRIL 13, 2005.
- 2) REFERENCE DEED FOR THE LOCUS PARCEL IS SPIDERFLIES LIMITED LIABILITY COMPANY TO RYAN AND CATHLEEN RICKARBY DATED APRIL 1, 2005 AND RECORDED IN DEED BOOK 22483, PAGE 66 RECORDED AT THE CUMBERLAND COUNTY REGISTRY OF DEEDS.
- 3) THE LOCUS PARCEL IS DEPICTED AS LOT 31 ON PORTLAND ASSESSORS MAP 83-E.
- 4) NO SUBSURFACE INVESTIGATION HAS BEEN PERFORMED BY SGC ENGINEERING, LLC. DIG-SAFE SHOULD BE CONTACTED PRIOR TO COMMENCING ANY EXCAVATION. (888-344-7233).
- 5) THIS PLAN IS THE RESULT OF A FIELD SURVEY CONDUCTED BY SGC ENGINEERING, LLC ON APRIL 19, 2005.
- 6) BEARINGS AND NORTH ARROW ORIENTATION AS SHOWN HEREON ARE BASED ON MAP REFERENCES.

DIAMOND COVE PHASE II
LOT 23

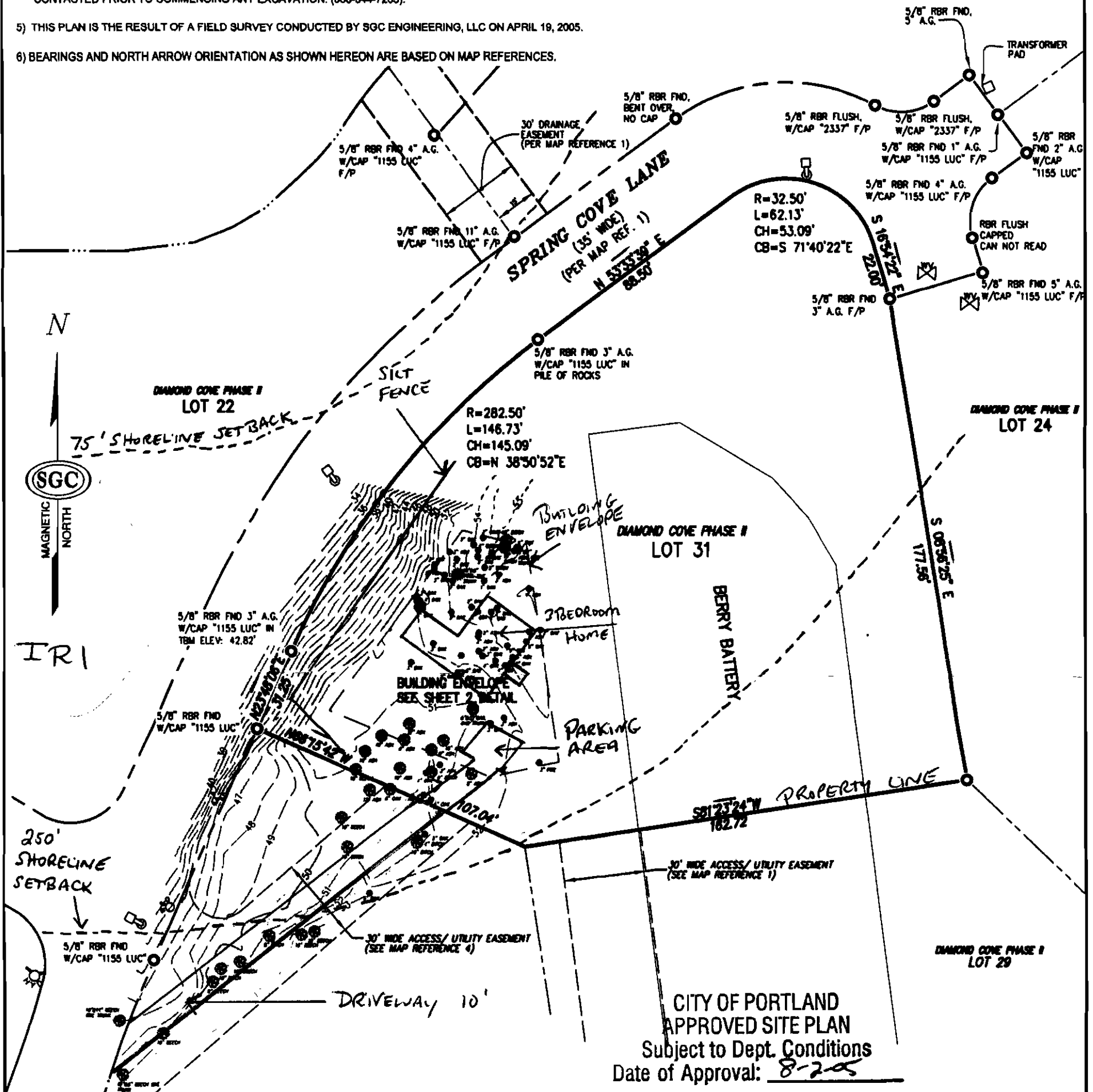

CITY OF PORTLAND
APPROVED SITE PLAN
Subject to Dept. Conditions
Date of Approval: 8-2-05

- LEGEND:**
- IRON PIPE OR ROD ----- ○
 - LAMP POST ----- □
 - WATER SHUT OFF ----- ⚡
 - FIRE HYDRANT ----- ⚡
 - WATER VALVE ----- ⚡

MAP REFERENCES:

- 1) PLAN ENTITLED "SKETCH SHOWING PROPOSED EASEMENTS, DIAMOND COVE PHASE II GREAT DIAMOND ISLAND, PORTLAND, MAINE" PREPARED FOR MCKINLEY PARTNERS LIMITED PARTNERSHIP, BY LAND USE CONSULTANTS, INC. DATED AUGUST 11, 1995.
- 2) PLAN ENTITLED "AMENDED RECORDING PLAT DIAMOND COVE PHASE II, SHEET 1 OF 3 GREAT DIAMOND ISLAND, PORTLAND, MAINE" PREPARED FOR DIAMOND COVE ASSOCIATES BY LAND USE CONSULTANTS, INC. CCRD PLAN BOOK 191 PAGE 143.
- 3) PLAN ENTITLED "UTILITY RECORD DRAWING, DIAMOND COVE PHASE II, WEST SIDE-29 LOTS, SHEET 2 OF 2 PREPARED FOR MCKINLEY PARTNERS LIMITED PARTNERSHIP, BY LAND USE CONSULTANTS, INC. DATED JUNE 15, 1995, THE PLAN IS NOT SEALED AND NOT RECORDED.
- 4) PLAN ENTITLED "ACCESS / UTILITY EASEMENT SKETCH PLAN, PREPARED FOR MCKINLEY PARTNERS LIMITED PARTNERSHIP, GREAT DIAMOND ISLAND, PORTLAND, MAINE" BY SGC ENGINEERING, LLC. DATED NOVEMBER 9, 1999.

SKETCH PLAN OF PROPERTY LOCATED ON
SPRING COVE LANE
GREAT DIAMOND ISLAND
PORTLAND, MAINE
PREPARED FOR
RYAN RICKARBY



SGC ENGINEERING, LLC
• Civil Design & Survey Engineering
• Environmental & Regulatory Permitting
• Electrical Power Systems Engineering

SERVING OUR CLIENTS IN THE U.S.A. & CANADA
501 County Road
Westbrook, Maine 04092
P.O. Box 470 Westbrook, 04098
Tel: 207-347-8100
Fax: 207-347-8101

Targel Technology Center
20 Godfrey Drive, Suite 200
Orono, Maine 04473
Tel: 207-885-6571
Fax: 207-885-6501

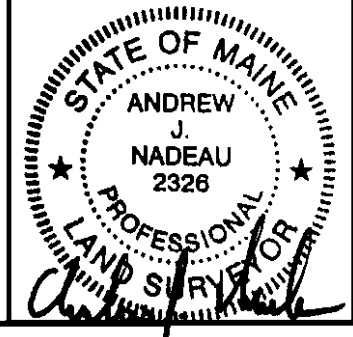

3 COUNTRY FARM ROAD, STRATHAM, NH, 03885

DATE: 05/03/05 SCALE: 1" = 40' DRAWN: CWM/CRM FILE: EXH_281004

SHEET 1 OF 2

GENERAL NOTES:

- 1) THIS PLAN AND ALL WORK ASSOCIATED WITH IT WAS PERFORMED BY SGC ENGINEERING, LLC PURSUANT TO A PROFESSIONAL SERVICES CONTRACT BETWEEN RYAN RICKARBY AND SGC ENGINEERING LLC, DATED APRIL 13, 2005.
- 2) REFERENCE DEED FOR THE LOCUS PARCEL IS SPIDERFLIES LIMITED LIABILITY COMPANY TO RYAN AND CATHEEN RICKARBY DATED APRIL 1, 2005 AND RECORDED IN DEED BOOK 22483, PAGE 66 RECORDED AT THE CUMBERLAND COUNTY REGISTRY OF DEEDS.
- 3) THE LOCUS PARCEL IS DEPICTED AS LOT 31 ON PORTLAND ASSESSORS MAP 83-E.
- 4) NO SUBSURFACE INVESTIGATION HAS BEEN PERFORMED BY SGC ENGINEERING, LLC. DIG-SAFE SHOULD BE CONTACTED PRIOR TO COMMENCING ANY EXCAVATION. (888-344-7233).
- 5) THIS PLAN IS THE RESULT OF A FIELD SURVEY CONDUCTED BY SGC ENGINEERING, LLC ON APRIL 19, 2005.
- 6) BEARINGS AND NORTH ARROW ORIENTATION AS SHOWN HEREON ARE BASED ON MAP REFERENCES.

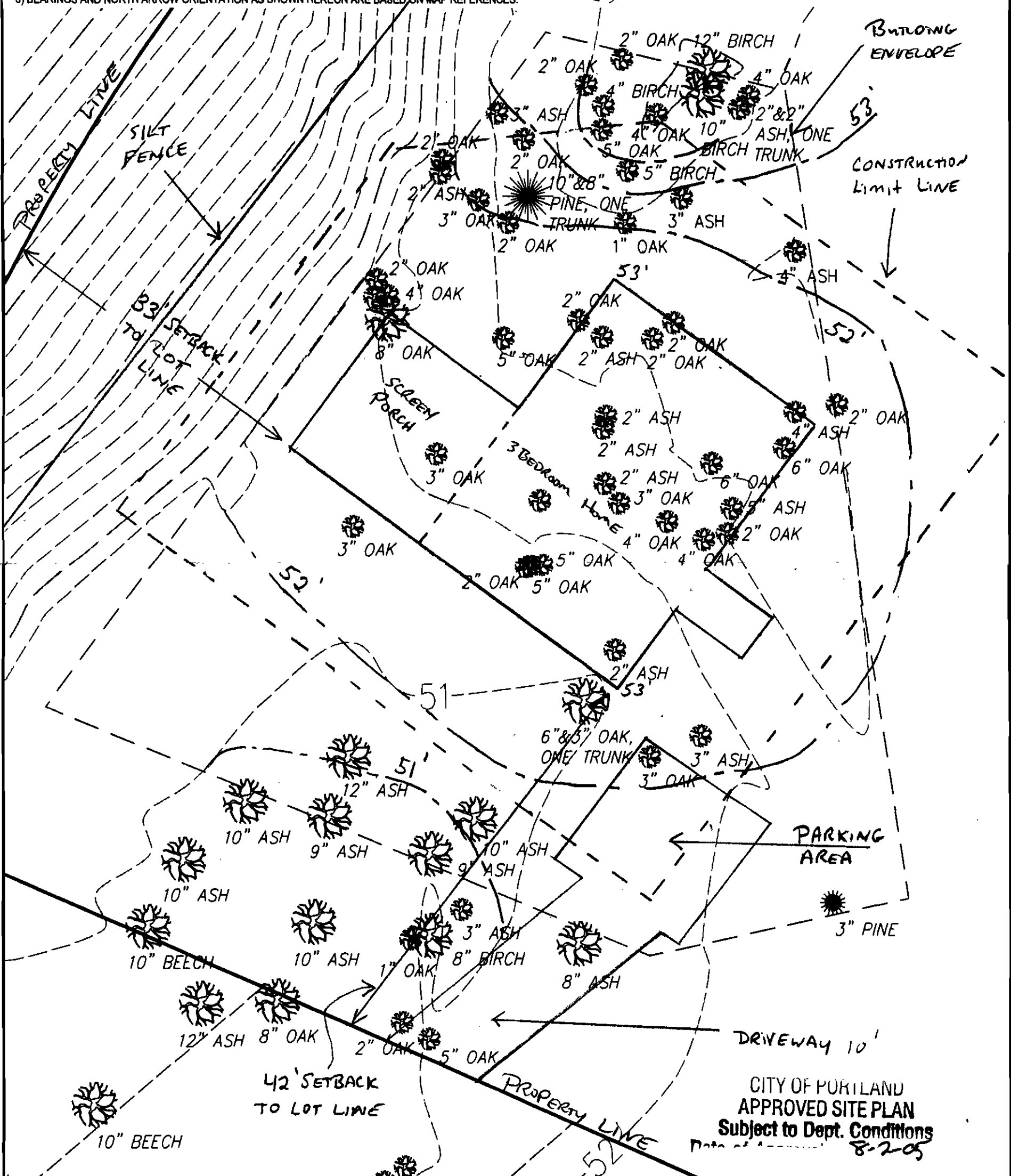

SKETCH PLAN OF PROPERTY LOCATED ON
SPRING COVE LANE
GREAT DIAMOND ISLAND
PORTLAND, MAINE

PREPARED FOR
RYAN RICKARBY

3 COUNTRY FARM ROAD, STRATHAM, NH, 03885



SGC ENGINEERING, LLC

- Civil Design & Survey Engineering
- Environmental & Regulatory Permitting
- Electrical Power Systems Engineering

SERVING OUR CLIENTS IN THE U.S.A. & CANADA

501 County Road
 Westbrook, Maine 04092
 P.O. Box 670 Westbrook, 04098
 Tel: 207-347-8100
 Fax: 207-347-4101

Target Technology Center
 20 Godfrey Drive, Suite 200
 Orono, Maine 04473
 Tel: 207-888-8571
 Fax: 207-888-8801

SHEET 2 OF 2

DATE: 05/03/05 SCALE: 1" = 10' DRAWN: CWM/CRM FILE: EXH_281004

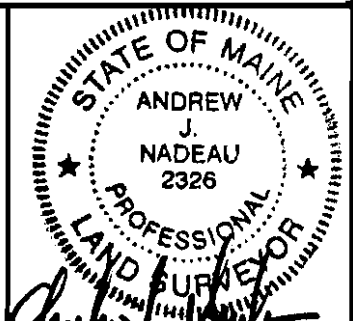

GENERAL NOTES:

- 1) THIS PLAN AND ALL WORK ASSOCIATED WITH IT WAS PERFORMED BY SGC ENGINEERING, LLC PURSUANT TO A PROFESSIONAL SERVICES CONTRACT BETWEEN RYAN RICKARBY AND SGC ENGINEERING LLC, DATED APRIL 13, 2005.
- 2) REFERENCE DEED FOR THE LOCUS PARCEL IS SPIDERFLIES LIMITED LIABILITY COMPANY TO RYAN AND CATHLEEN RICKARBY DATED APRIL 1, 2005 AND RECORDED IN DEED BOOK 22483, PAGE 68 RECORDED AT THE CUMBERLAND COUNTY REGISTRY OF DEEDS.
- 3) THE LOCUS PARCEL IS DEPICTED AS LOT 31 ON PORTLAND ASSESSORS MAP 83-E.
- 4) NO SUBSURFACE INVESTIGATION HAS BEEN PERFORMED BY SGC ENGINEERING, LLC. DIG-SAFE SHOULD BE CONTACTED PRIOR TO COMMENCING ANY EXCAVATION. (688-344-7233).
- 5) THIS PLAN IS THE RESULT OF A FIELD SURVEY CONDUCTED BY SGC ENGINEERING, LLC ON APRIL 19, 2005.
- 6) BEARINGS AND NORTH ARROW ORIENTATION AS SHOWN HEREON ARE BASED ON MAP REFERENCES.

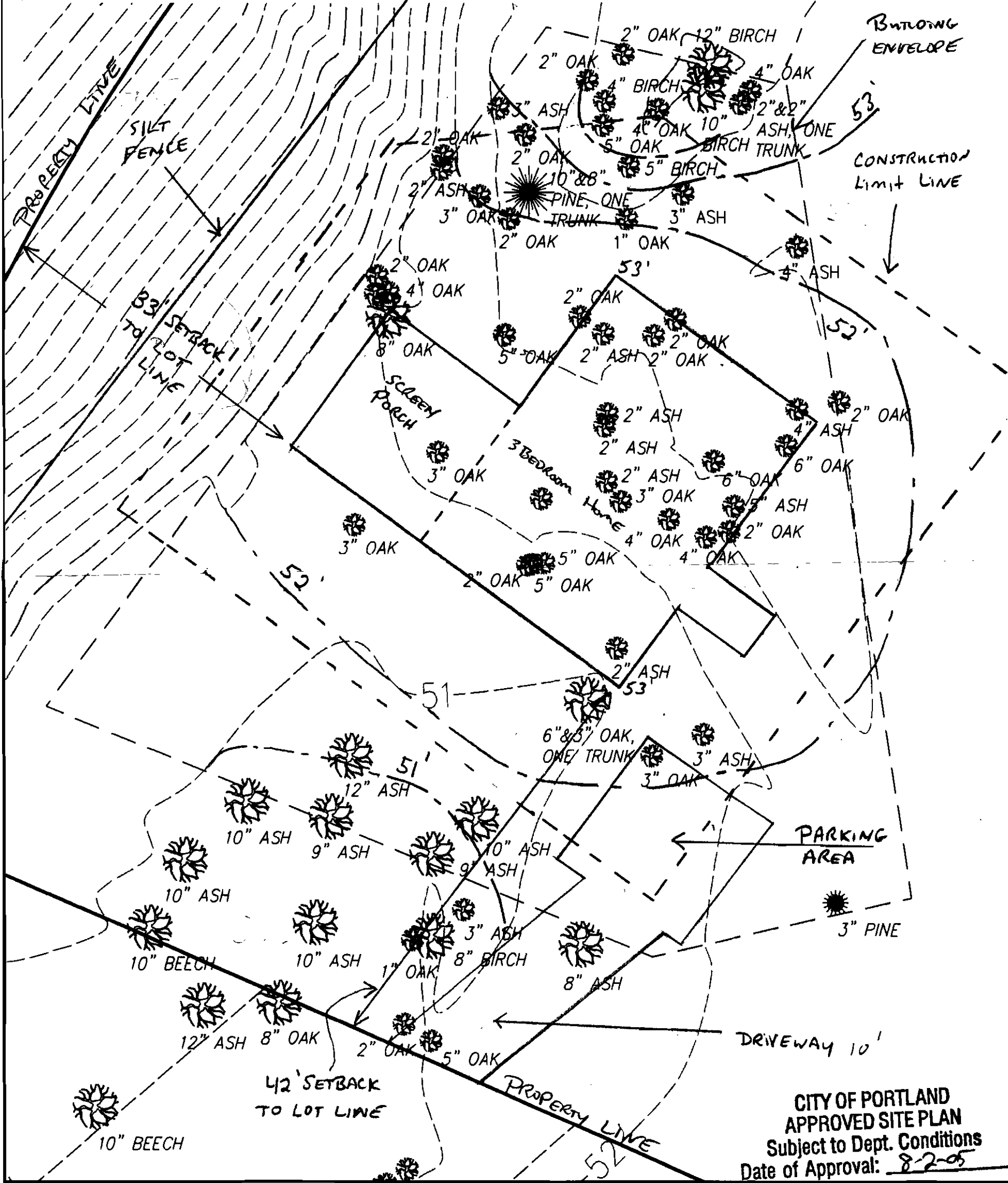

**CITY OF PORTLAND
APPROVED SITE PLAN**
Subject to Dept. Conditions
Date of Approval: 8-2-05

SKETCH PLAN OF PROPERTY LOCATED ON
SPRING COVE LANE
GREAT DIAMOND ISLAND
PORTLAND, MAINE
PREPARED FOR
RYAN RICKARBY
3 COUNTRY FARM ROAD, STRATHAM, NH, 03885



SGC ENGINEERING, LLC
• Civil Design & Survey Engineering
• Environmental & Regulatory Permitting
• Electrical Power Systems Engineering

SERVING OUR CLIENTS IN THE U.S.A. & CANADA
801 County Road
Westbrook, Maine 04092
P.O. Box 470 Westbrook, 04098
Tel: 207-866-8100
Fax: 207-347-4101
Target Technology Center
20 Godfrey Drive, Suite 200
Orono, Maine 04473
Tel: 207-886-8671
Fax: 207-886-8801

SHEET 2 OF 2

DATE: 05/03/05 SCALE: 1" = 10' DRAWN: CWM/CRM FILE: EXH_281004

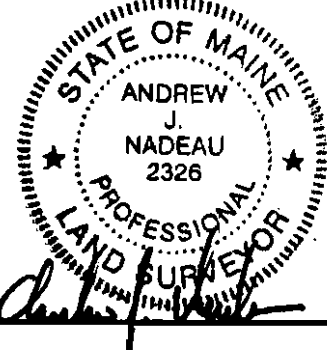

GENERAL NOTES:

- 1) THIS PLAN AND ALL WORK ASSOCIATED WITH IT WAS PERFORMED BY SGC ENGINEERING, LLC PURSUANT TO A PROFESSIONAL SERVICES CONTRACT BETWEEN RYAN RICKARBY AND SGC ENGINEERING LLC, DATED APRIL 13, 2005.
- 2) REFERENCE DEED FOR THE LOCUS PARCEL IS SPIDERFLIES LIMITED LIABILITY COMPANY TO RYAN AND CATHLEEN RICKARBY DATED APRIL 1, 2005 AND RECORDED IN DEED BOOK 22483, PAGE 66 RECORDED AT THE CUMBERLAND COUNTY REGISTRY OF DEEDS.
- 3) THE LOCUS PARCEL IS DEPICTED AS LOT 31 ON PORTLAND ASSESSORS MAP 83-E.
- 4) NO SUBSURFACE INVESTIGATION HAS BEEN PERFORMED BY SGC ENGINEERING, LLC. DIG-SAFE SHOULD BE CONTACTED PRIOR TO COMMENCING ANY EXCAVATION. (888-344-7233).
- 5) THIS PLAN IS THE RESULT OF A FIELD SURVEY CONDUCTED BY SGC ENGINEERING, LLC ON APRIL 19, 2005.
- 6) BEARINGS AND NORTH ARROW ORIENTATION AS SHOWN HEREON ARE BASED ON MAP REFERENCES.

DIAMOND COVE PHASE II
LOT 23

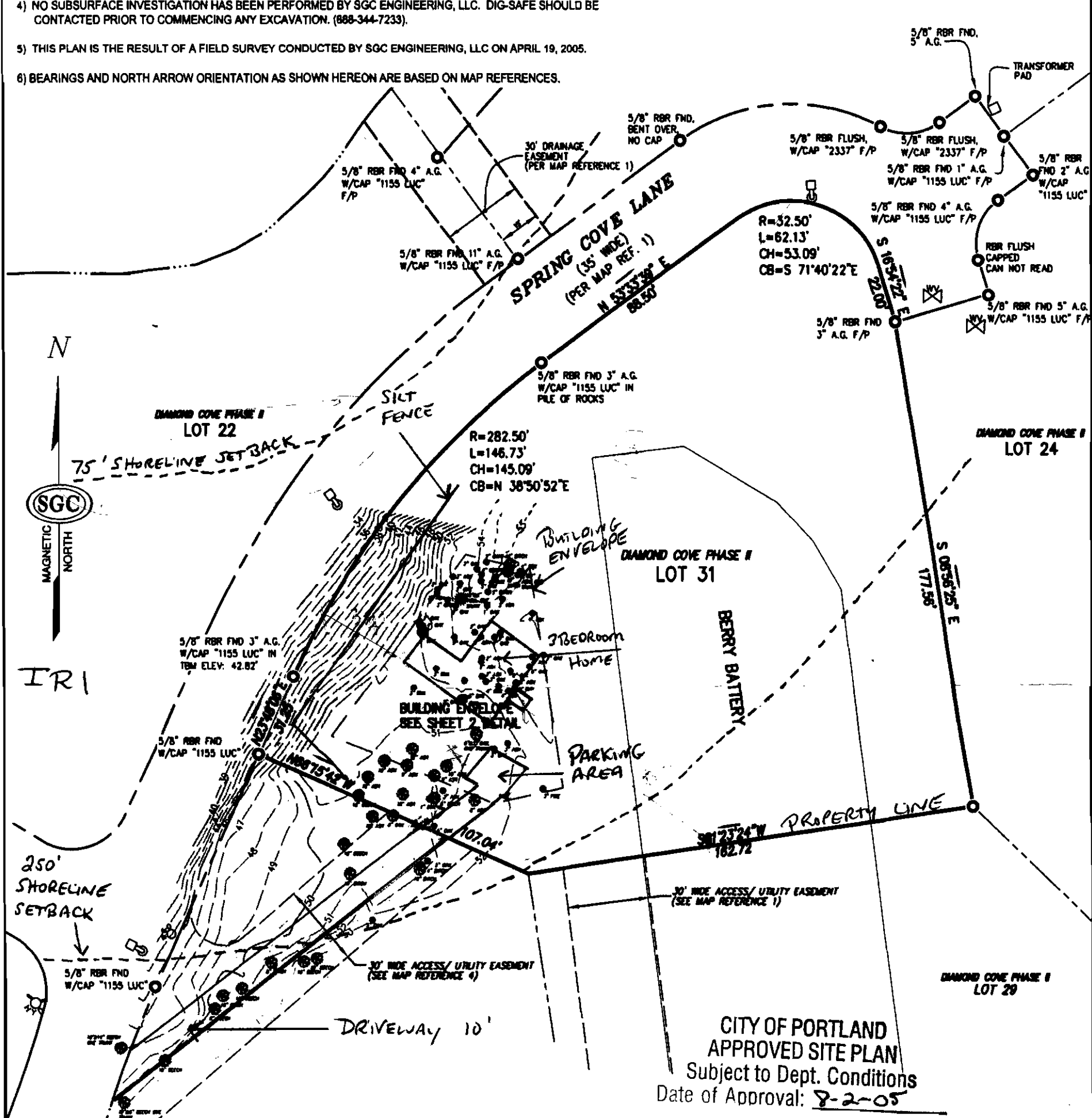

CITY OF PORTLAND
APPROVED SITE PLAN
Subject to Dept. Conditions
Date of Approval: 8-2-05

MAP REFERENCES:

- 1) PLAN ENTITLED "SKETCH SHOWING PROPOSED EASEMENTS, DIAMOND COVE PHASE II GREAT DIAMOND ISLAND, PORTLAND, MAINE" PREPARED FOR MCKINLEY PARTNERS LIMITED PARTNERSHIP, BY LAND USE CONSULTANTS, INC. DATED AUGUST 11, 1995.
- 2) PLAN ENTITLED "AMENDED RECORDING PLAT DIAMOND COVE PHASE II, SHEET 1 OF 3 GREAT DIAMOND ISLAND, PORTLAND, MAINE" PREPARED FOR DIAMOND COVE ASSOCIATES BY LAND USE CONSULTANTS, INC. CCRD PLAN BOOK 191 PAGE 143.
- 3) PLAN ENTITLED "UTILITY RECORD DRAWING, DIAMOND COVE PHASE II, WEST SIDE-29 LOTS, SHEET 2 OF 2 PREPARED FOR MCKINLEY PARTNERS LIMITED PARTNERSHIP, BY LAND USE CONSULTANTS, INC. DATED JUNE 15, 1995, THE PLAN IS NOT SEALED AND NOT RECORDED.
- 4) PLAN ENTITLED "ACCESS / UTILITY EASEMENT SKETCH PLAN, PREPARED FOR MCKINLEY PARTNERS LIMITED PARTNERSHIP, GREAT DIAMOND ISLAND, PORTLAND, MAINE" BY SGC ENGINEERING, LLC. DATED NOVEMBER 9, 1999.

LEGEND:

- IRON PIPE OR ROD ——— ○
- LAMP POST ——— □
- WATER SHUT OFF ——— ⊕
- FIRE HYDRANT ——— ⊕
- WATER VALVE ——— ⊕

SKETCH PLAN OF PROPERTY LOCATED ON
SPRING COVE LANE
GREAT DIAMOND ISLAND
PORTLAND, MAINE
PREPARED FOR
RYAN RICKARBY
3 COUNTRY FARM ROAD, STRATHAM, NH, 03885



SGC ENGINEERING, LLC
• Civil Design & Survey Engineering
• Environmental & Regulatory Permitting
• Electrical Power Systems Engineering

SERVING OUR CLIENTS IN THE U.S.A. & CANADA
801 County Road
Westbrook, Maine 04092
P.O. Box 470 Westbrook, 04098
Tel: 207-347-9100
Fax: 207-347-9101
Target Technology Center
20 Godfrey Drive, Suite 200
Orono, Maine 04473
Tel: 207-888-8871
Fax: 207-888-8801



SHEET 1 OF 2

DATE: 05/03/05 SCALE: 1" = 40' DRAWN: CWM/CRM FILE: EXH_281004

LOT #31 DIAMOND COVE
Ryan & Cathy Rickarby

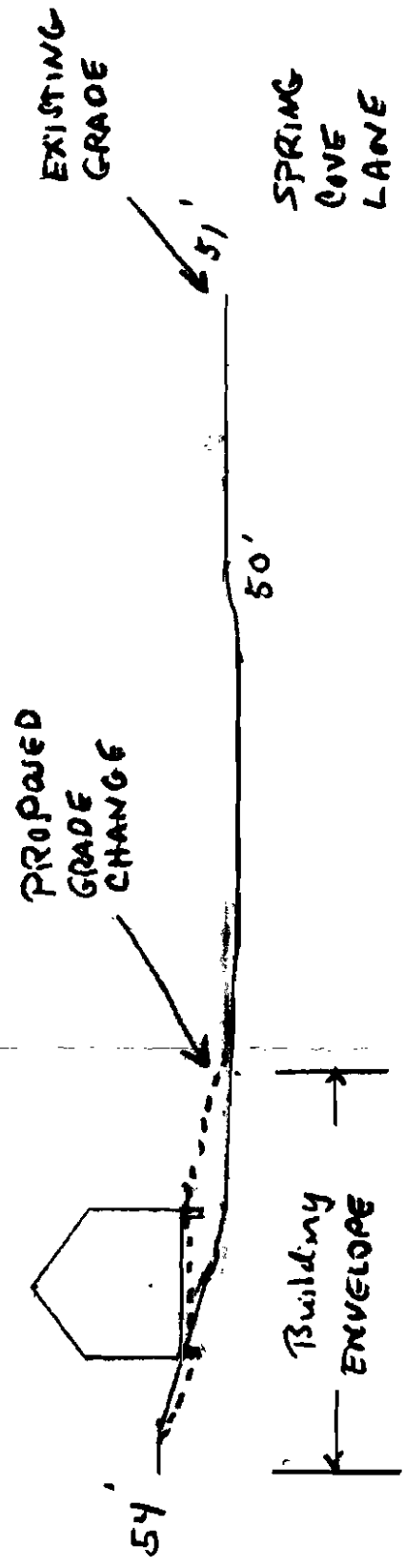

NE.

SW.

SCALE 1" = 40'

LOT #31 DIAMOND COVE

NO PLANS TO CHANGE EXISTING GRADE.

TREE CANOPY 40'-50' EST.

Ryan & Cathy Rickaby

NORTH
WEST

SOUTH
EAST

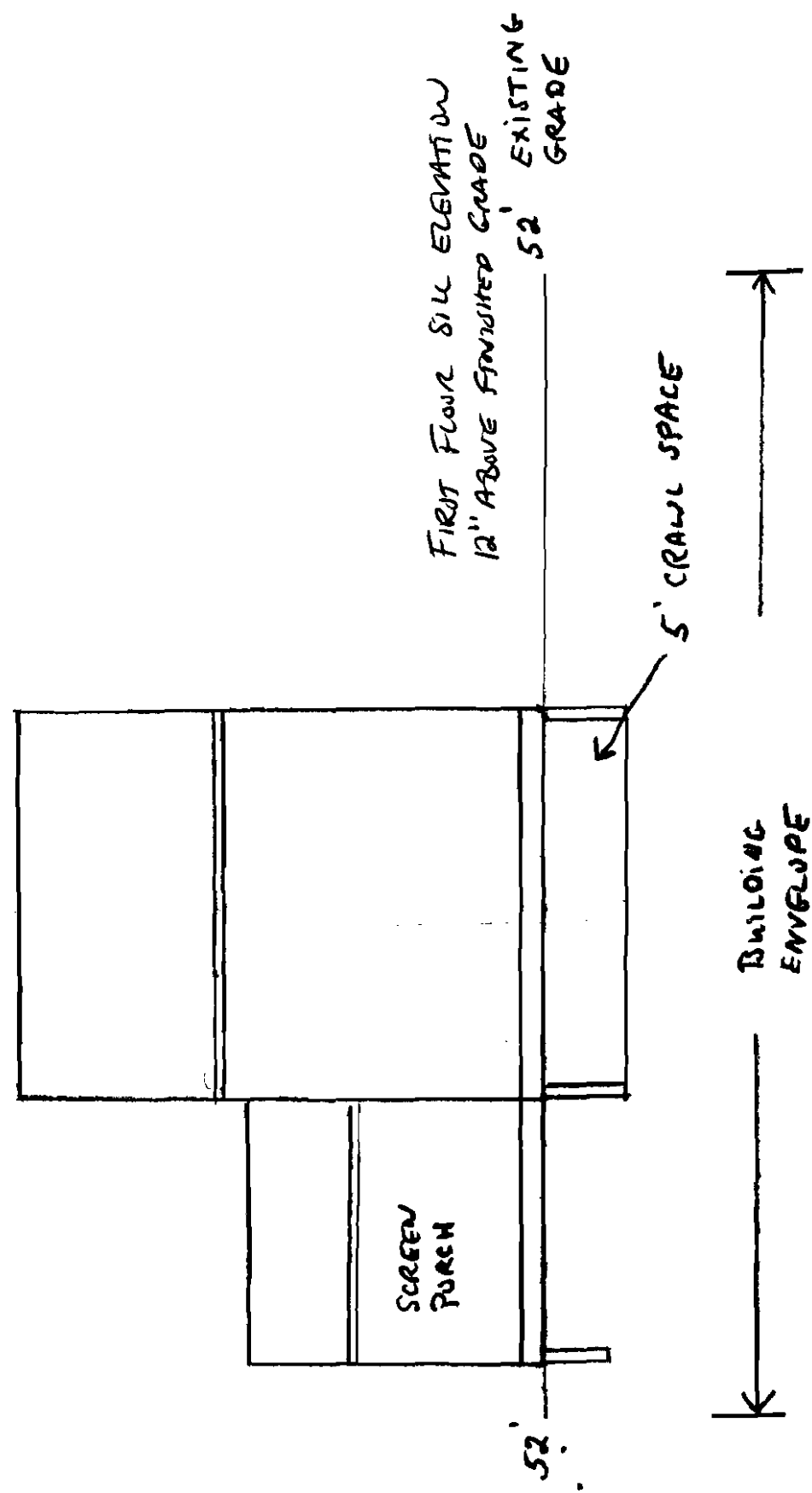

SCREEN
PORCH

FIRST FLOOR SILL ELEVATION
12" ABOVE FINISHED GRADE
52' EXISTING
GRADE

5' CRAWL SPACE

BUILDING
ENVELOPE

52'

43'

34'

SPRING
COVE
LANE

SCALE 1" = 10'

GENERAL NOTES:

- 1) THIS PLAN AND ALL WORK ASSOCIATED WITH IT WAS PERFORMED BY SGC ENGINEERING, LLC PURSUANT TO A PROFESSIONAL SERVICES CONTRACT BETWEEN RYAN RICKARBY AND SGC ENGINEERING LLC, DATED APRIL 13, 2005.
- 2) REFERENCE DEED FOR THE LOCUS PARCEL IS SPIDERFLIES LIMITED LIABILITY COMPANY TO RYAN AND CATHLEEN RICKARBY DATED APRIL 1, 2005 AND RECORDED IN DEED BOOK 22483, PAGE 66 RECORDED AT THE CUMBERLAND COUNTY REGISTRY OF DEEDS.
- 3) THE LOCUS PARCEL IS DEPICTED AS LOT 31 ON PORTLAND ASSESSORS MAP 83-E.
- 4) NO SUBSURFACE INVESTIGATION HAS BEEN PERFORMED BY SGC ENGINEERING, LLC. DIG-SAFE SHOULD BE CONTACTED PRIOR TO COMMENCING ANY EXCAVATION. (888-344-7233).
- 5) THIS PLAN IS THE RESULT OF A FIELD SURVEY CONDUCTED BY SGC ENGINEERING, LLC ON APRIL 19, 2005.
- 6) BEARINGS AND NORTH ARROW ORIENTATION AS SHOWN HEREON ARE BASED ON MAP REFERENCES.

**DIAMOND COVE PHASE II
LOT 23**

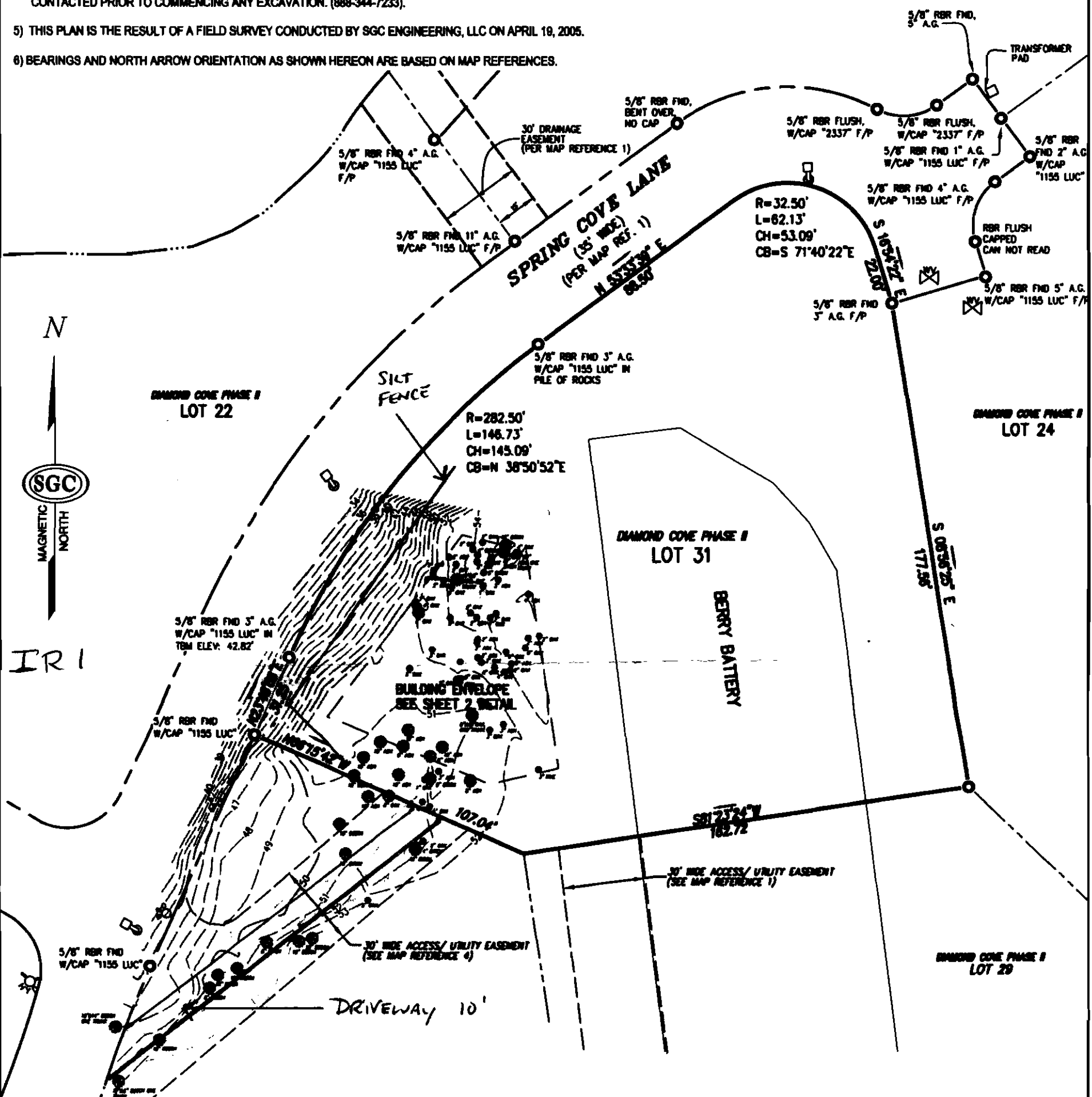

IR 1

- LEGEND:**
- IRON PIPE OR ROD --- ○
 - LAMP POST --- □
 - WATER SHUT OFF --- ⚙
 - FIRE HYDRANT --- ⚡
 - WATER VALVE --- ⚙

MAP REFERENCES:

- 1) PLAN ENTITLED "SKETCH SHOWING PROPOSED EASEMENTS, DIAMOND COVE PHASE II GREAT DIAMOND ISLAND, PORTLAND, MAINE" PREPARED FOR MCKINLEY PARTNERS LIMITED PARTNERSHIP, BY LAND USE CONSULTANTS, INC. DATED AUGUST 11, 1995.
- 2) PLAN ENTITLED "AMENDED RECORDING PLAT DIAMOND COVE PHASE II, SHEET 1 OF 3 GREAT DIAMOND ISLAND, PORTLAND, MAINE" PREPARED FOR DIAMOND COVE ASSOCIATES BY LAND USE CONSULTANTS, INC. CCRD PLAN BOOK 191 PAGE 143.
- 3) PLAN ENTITLED "UTILITY RECORD DRAWING, DIAMOND COVE PHASE II, WEST SIDE-29 LOTS, SHEET 2 OF 2 PREPARED FOR MCKINLEY PARTNERS LIMITED PARTNERSHIP, BY LAND USE CONSULTANTS, INC. DATED JUNE 15, 1995, THE PLAN IS NOT SEALED AND NOT RECORDED.
- 4) PLAN ENTITLED "ACCESS / UTILITY EASEMENT SKETCH PLAN, PREPARED FOR MCKINLEY PARTNERS LIMITED PARTNERSHIP, GREAT DIAMOND ISLAND, PORTLAND, MAINE" BY SGC ENGINEERING, LLC. DATED NOVEMBER 9, 1999.

SKETCH PLAN OF PROPERTY LOCATED ON
SPRING COVE LANE
GREAT DIAMOND ISLAND
PORTLAND, MAINE
PREPARED FOR
RYAN RICKARBY
3 COUNTRY FARM ROAD, STRATHAM, NH, 03885



SGC ENGINEERING, LLC
• Civil Design & Survey Engineering
• Environmental & Regulatory Permitting
• Electrical Power Systems Engineering

SERVING OUR CLIENTS IN THE U.S.A. & CANADA
801 Country Road
Westbrook, Maine 04092
P.O. Box 470 Westbrook, 04092
Tel: 207-947-9100
Fax: 207-947-9101

Target Technology Center
30 Godfrey Drive, Suite 200
Orono, Maine 04473
Tel: 207-688-6571
Fax: 207-688-6501

SHEET 1 OF 2

DATE: 05/03/05 SCALE: 1" = 40' DRAWN: CWM/CRM FILE: EXH_281004

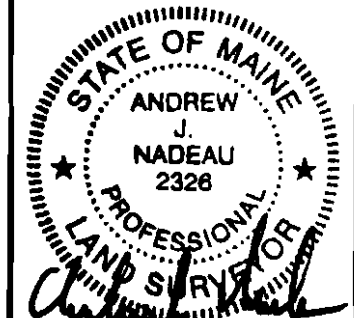

1.2 83-E
GREAT DIAMOND

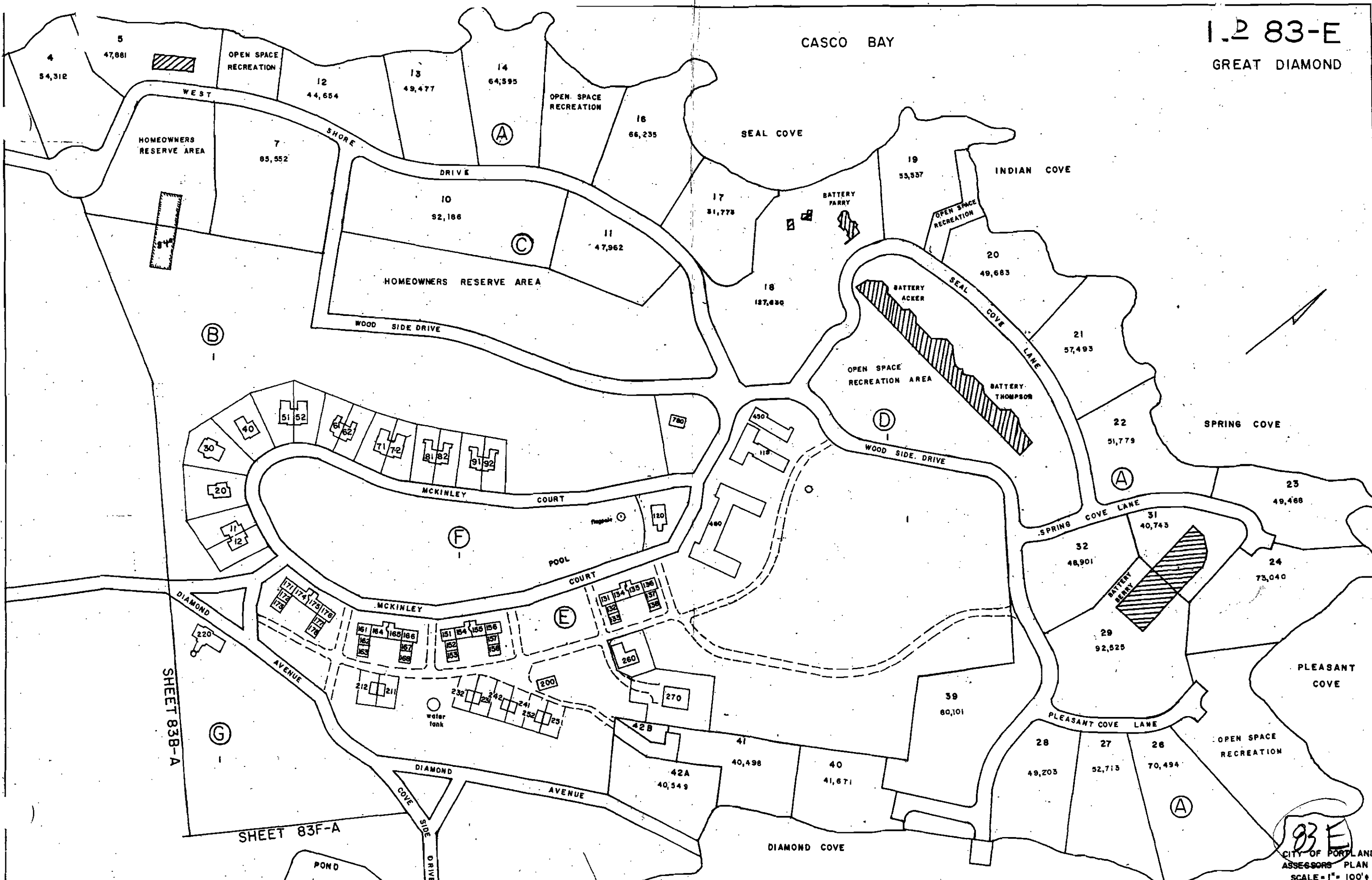

NO.	DATE	DESCRIPTION
1	08/07/08	ISSUE FOR PERMIT

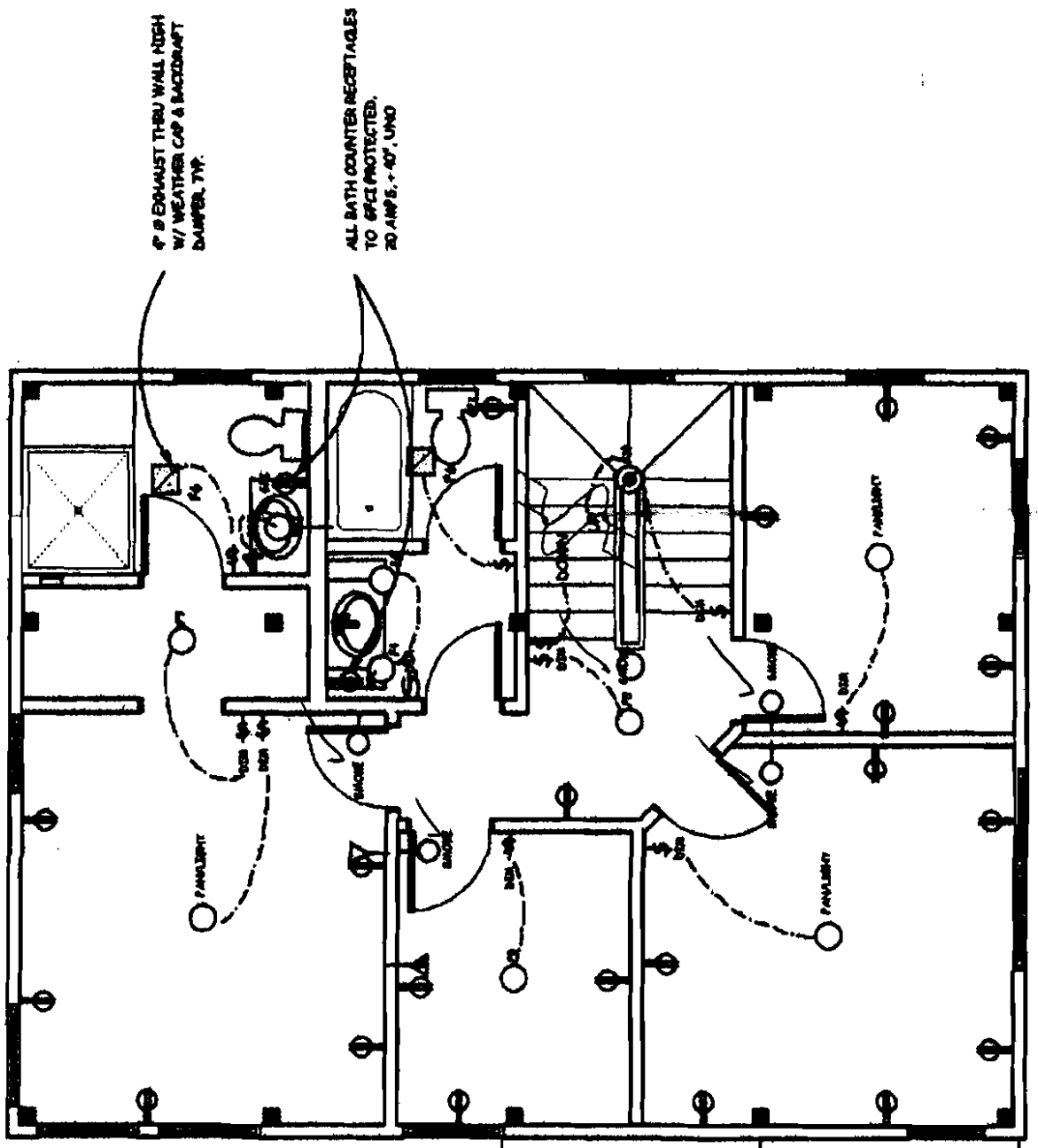

(B) SECOND FLOOR - ELEC PLAN
1/17/10

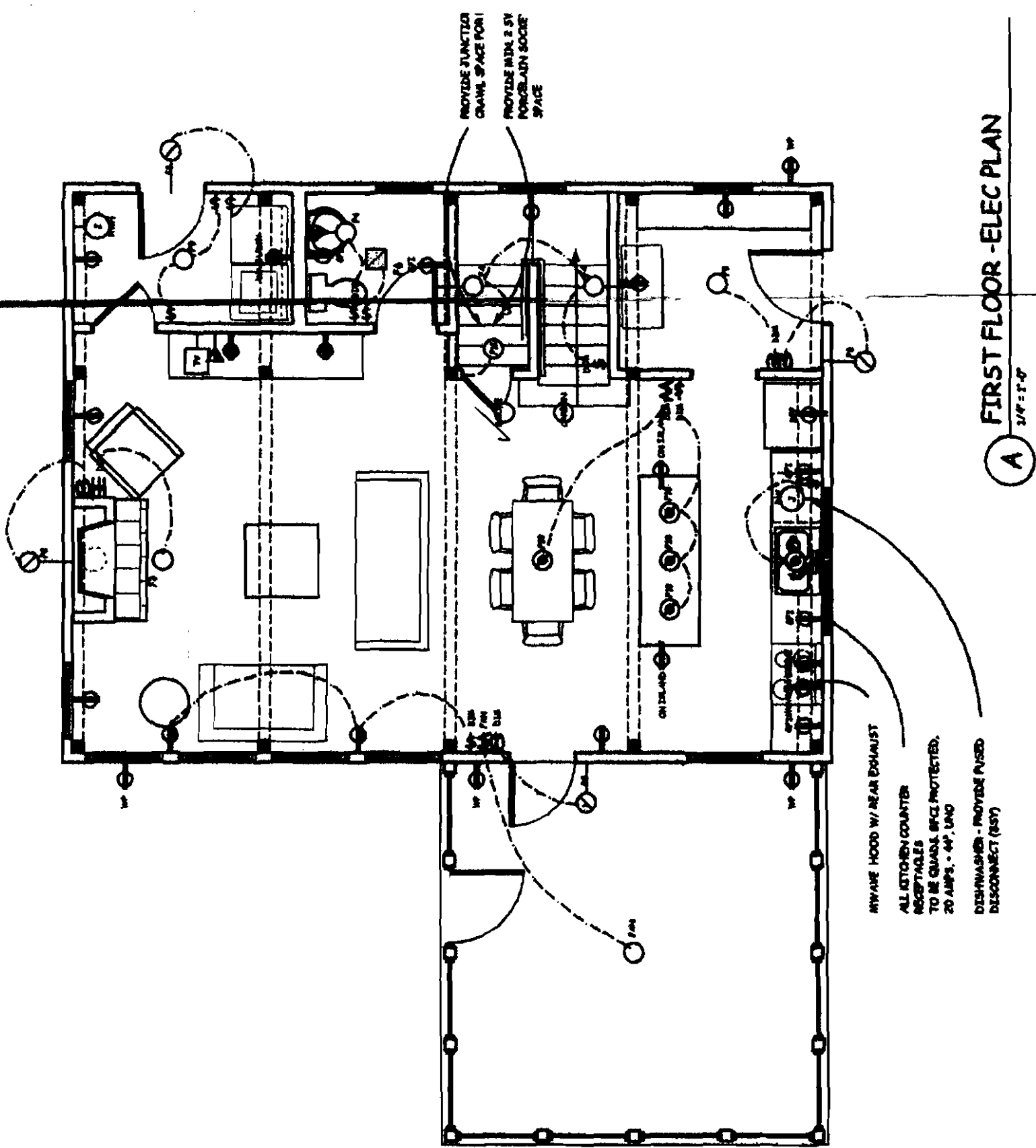

FIRST FLOOR - ELEC PLAN

A 3/4" = 1'-0"

AIRWARE HOOD W/ REAR EXHAUST
 ALL KITCHEN COUNTER
 RECEPTACLES
 TO BE QUAD. (GFCI PROTECTED).
 20 AMP. - 4P, LINO
 DISHWASHER - PROVIDE FUSED
 DISCONNECT (FSD)

PROVIDE JUNCTION
 BOX, SPACE FOR 1
 PROVIDE MIN. 2 SV
 FOR CLOSET SOCKS
 SPACE

ON ISLAND