

This drawing is an instrument of professional service, and shall not be used, in whole or in part, for any project other than for which it was created without the express, written consent of M<sup>2</sup> Structural Engineering, P.C. Any unauthorized use, reuse, modification or alteration, including automated conversion of this document shall be at the user's sole risk without liability or legal exposure to M<sup>2</sup> Structural Engineering, P.C.

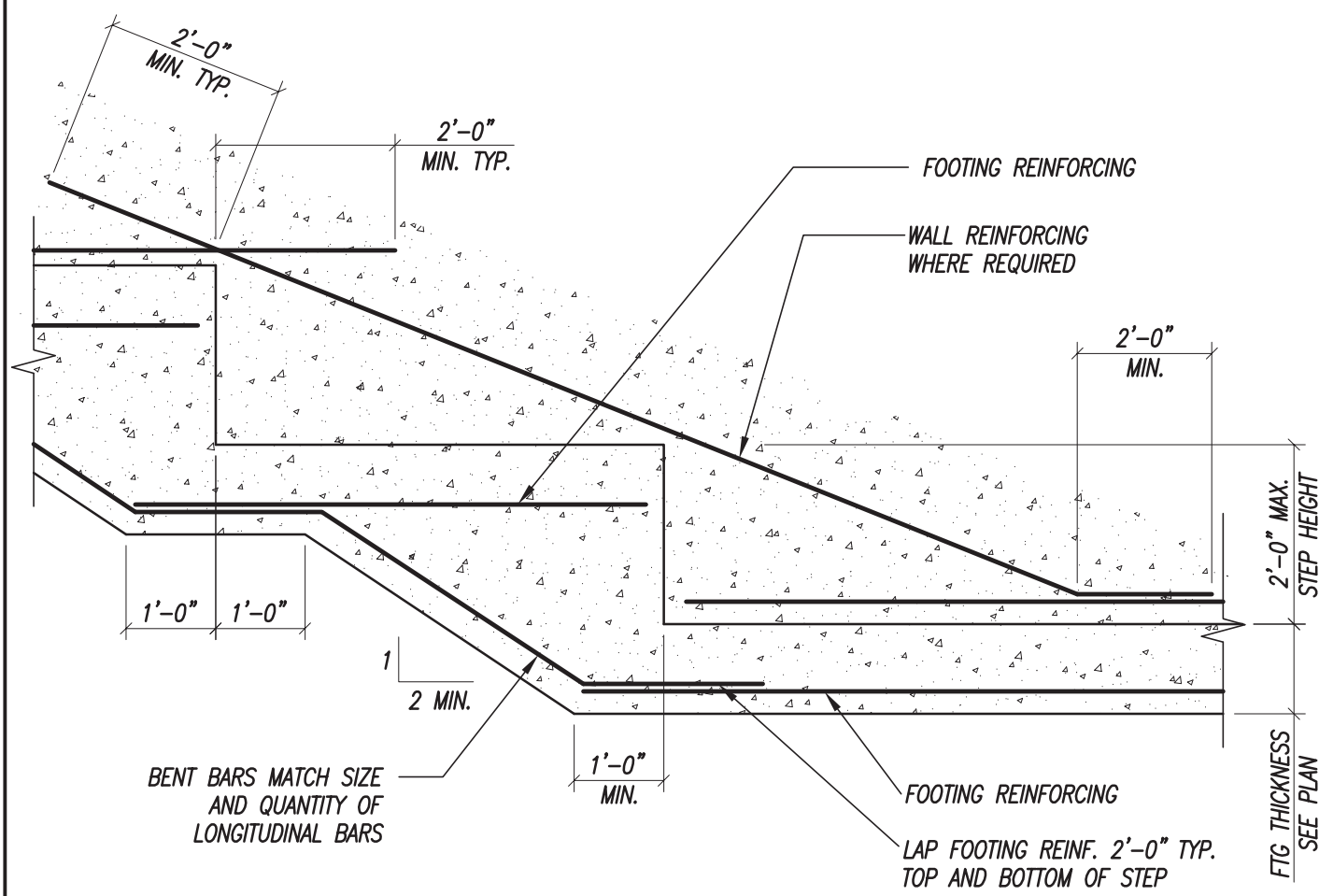

**1 TYPICAL FOOTING STEP DETAIL**  
1/2" = 1'-0"

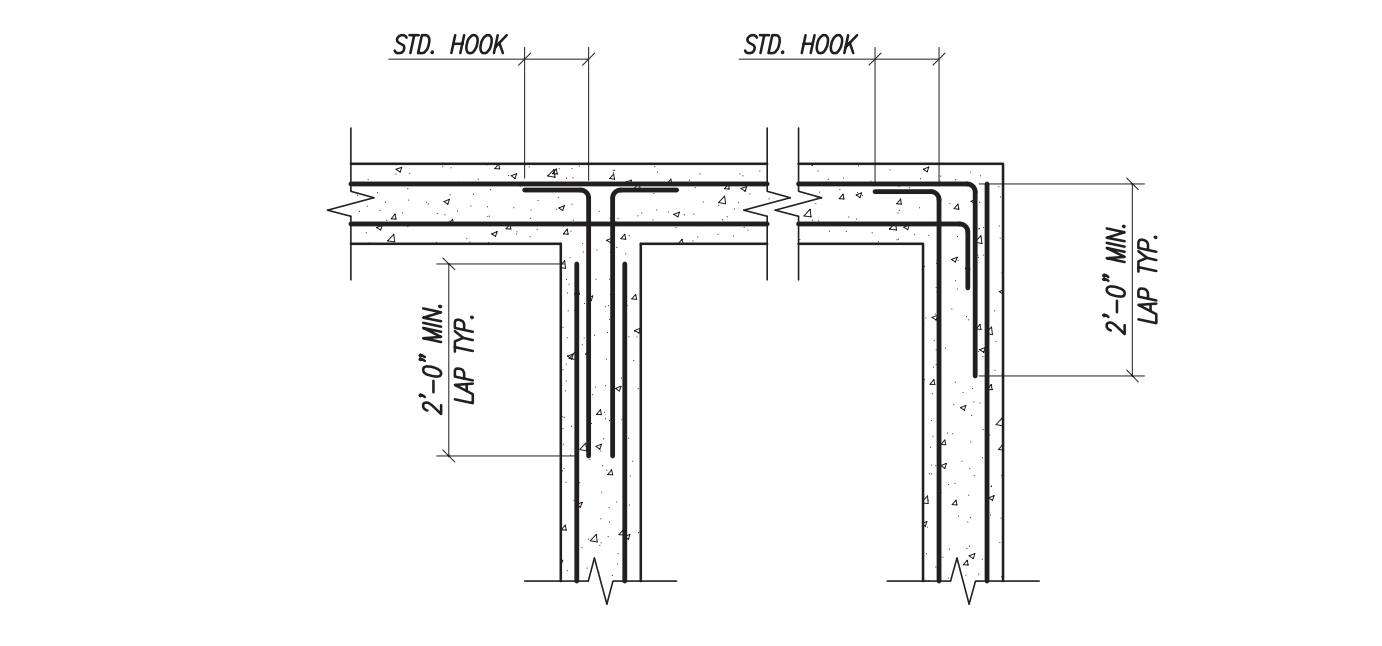

**2 TYPICAL CORNER/INTERSECTION REINFORCING**  
1/2" = 1'-0"

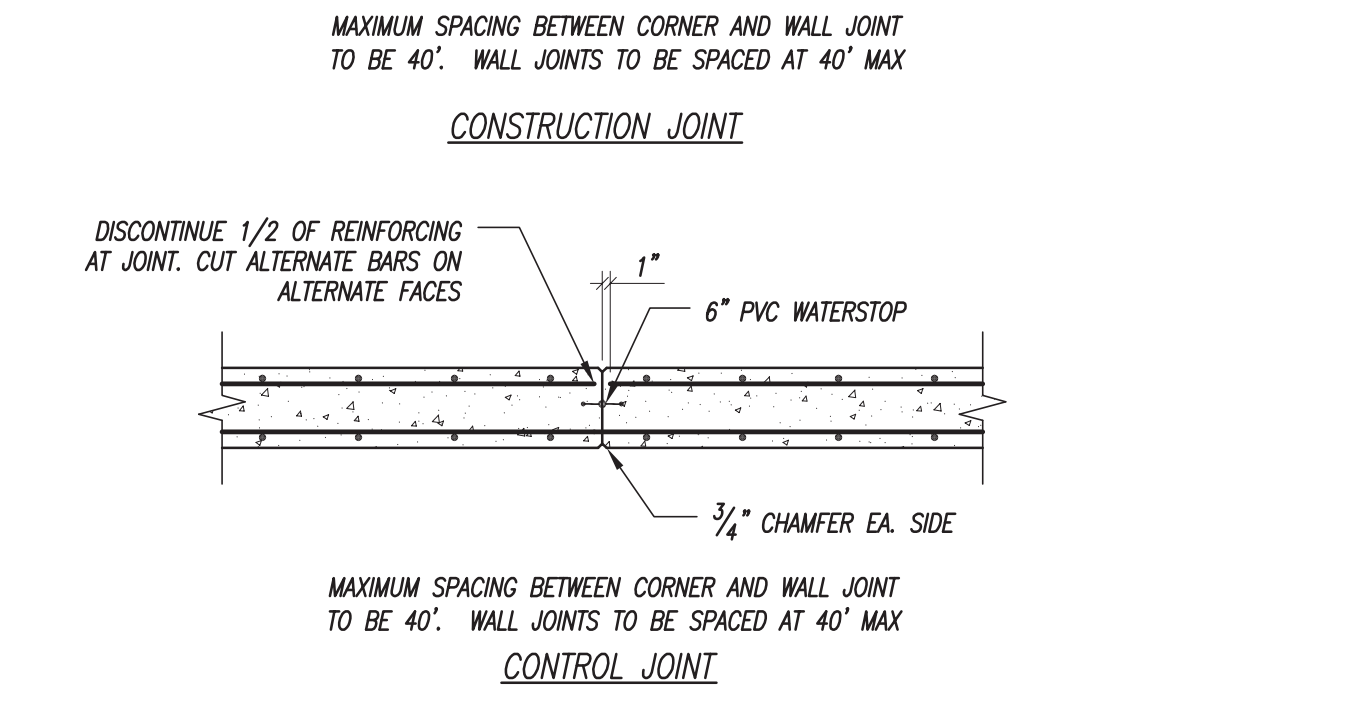
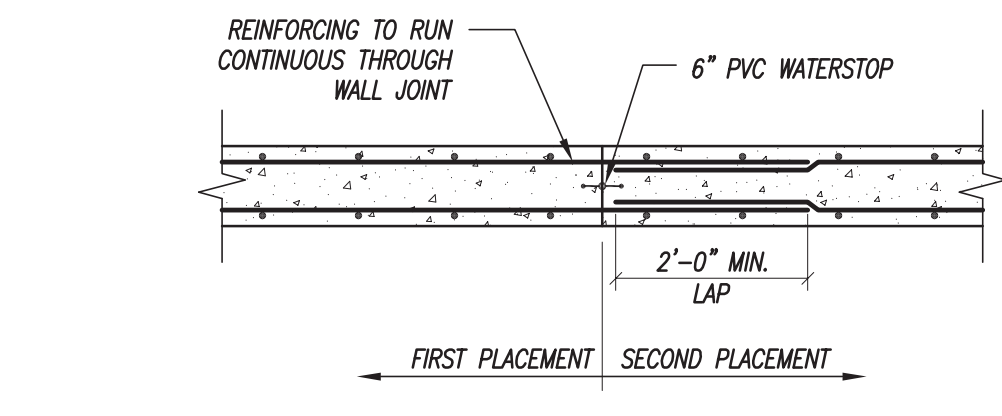

**3 TYPICAL WALL CONSTRUCTION/CONTROL JOINT**  
1/2" = 1'-0"

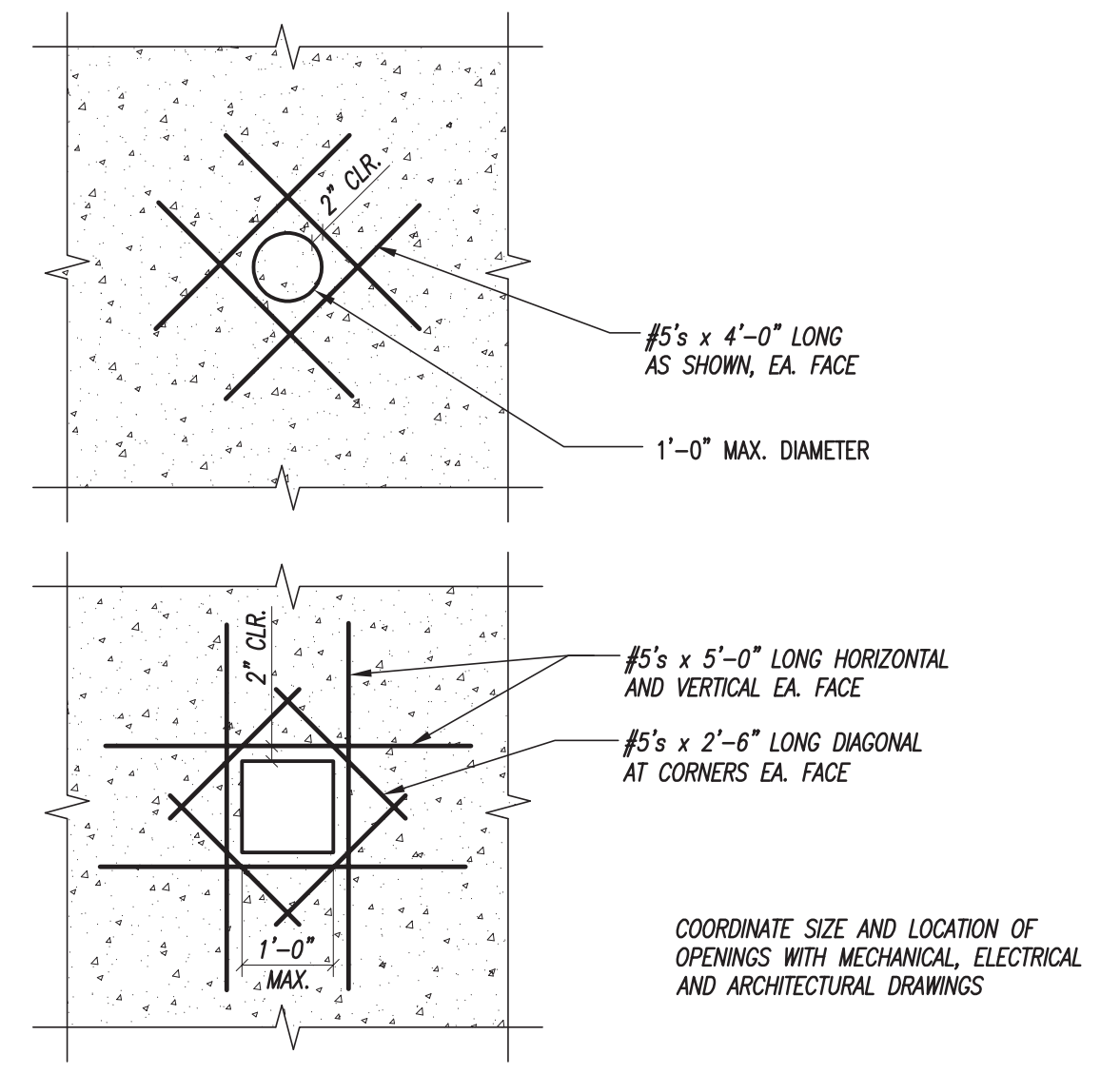

**4 TYPICAL WALL PENETRATION DETAIL**  
1/2" = 1'-0"

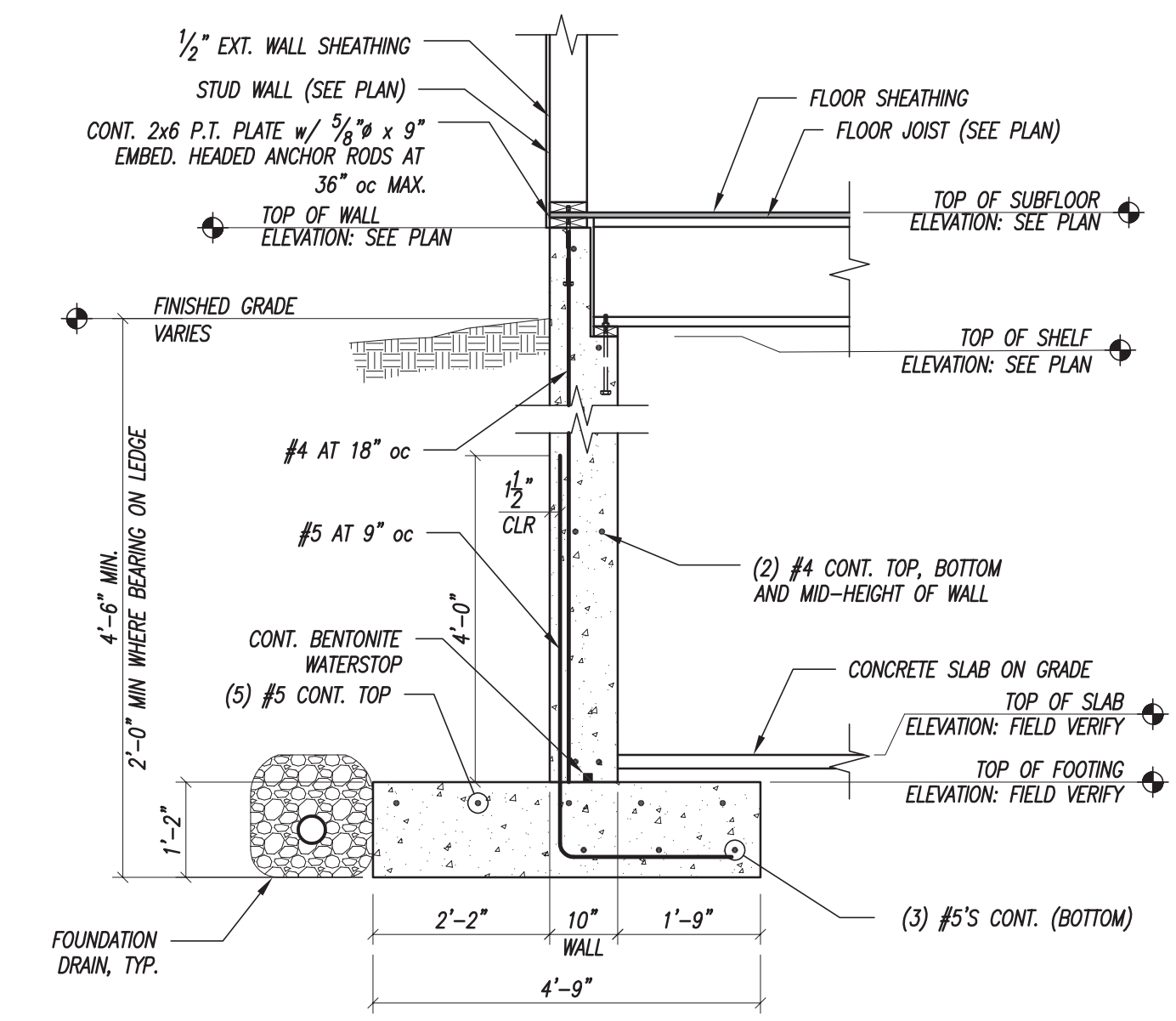

**5 SECTION**  
1/2" = 1'-0"

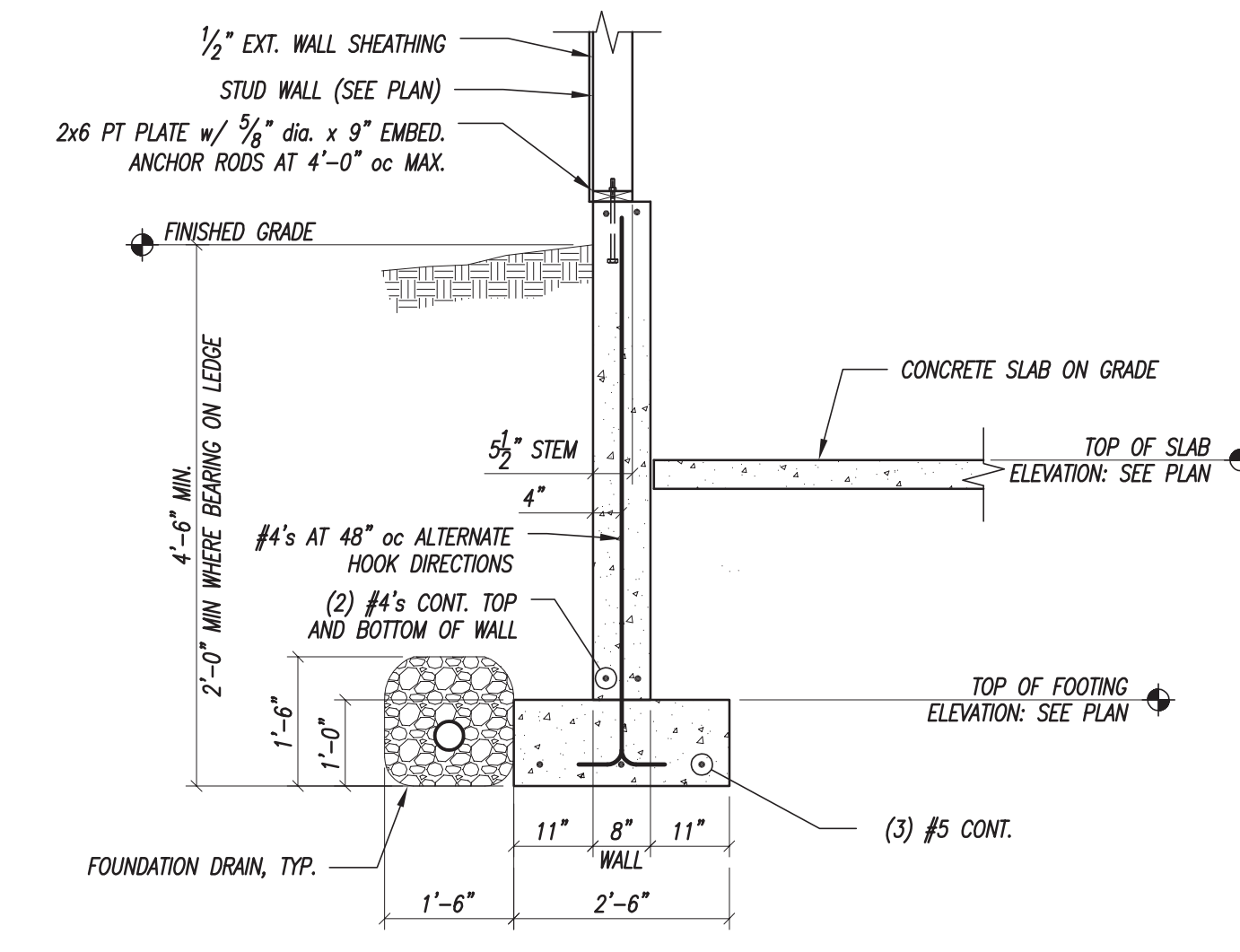

**6 SECTION**  
1/2" = 1'-0"

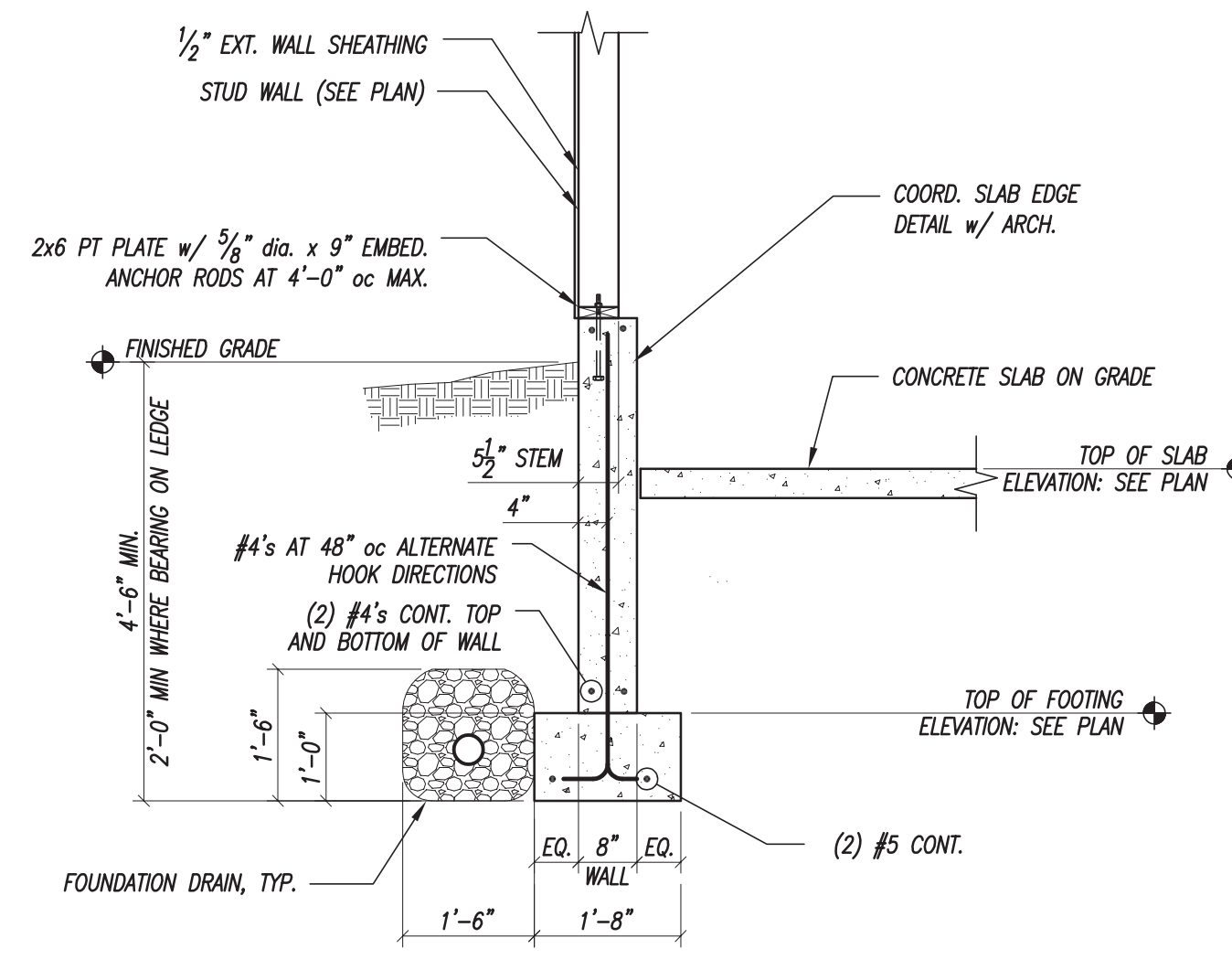

**7 SECTION**  
1/2" = 1'-0"

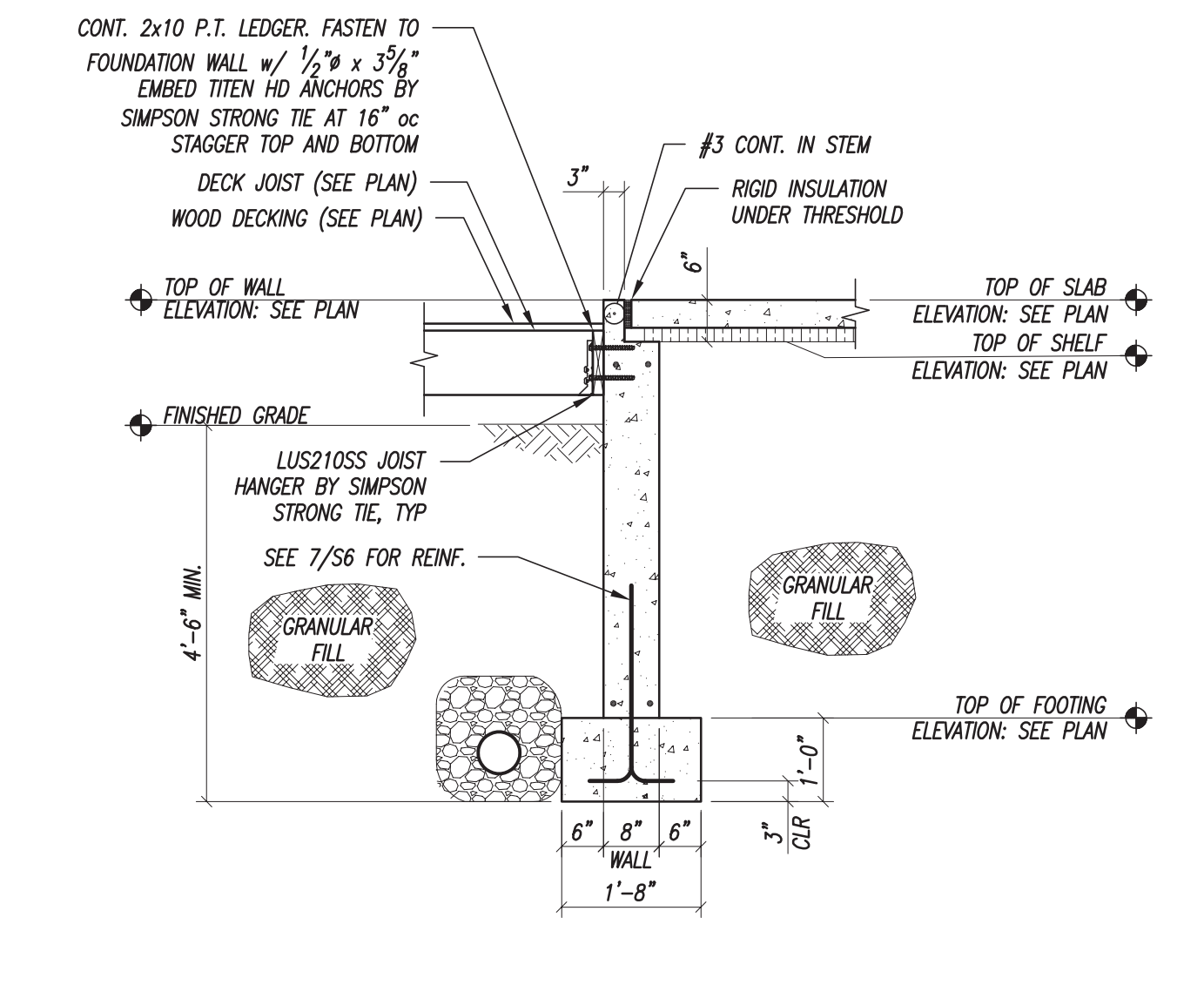

**8 SECTION**  
1/2" = 1'-0"

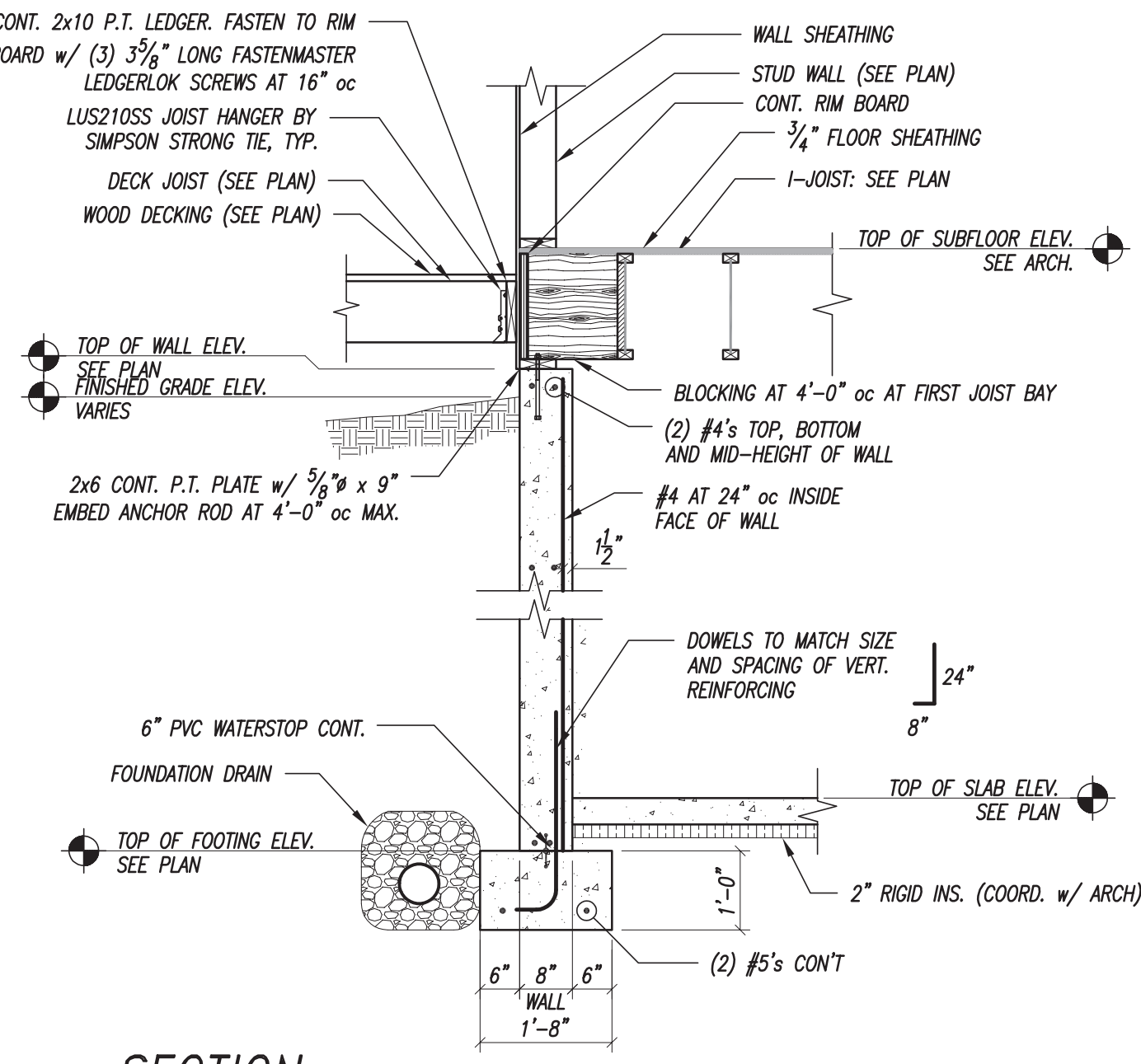

**9 SECTION**  
1/2" = 1'-0"

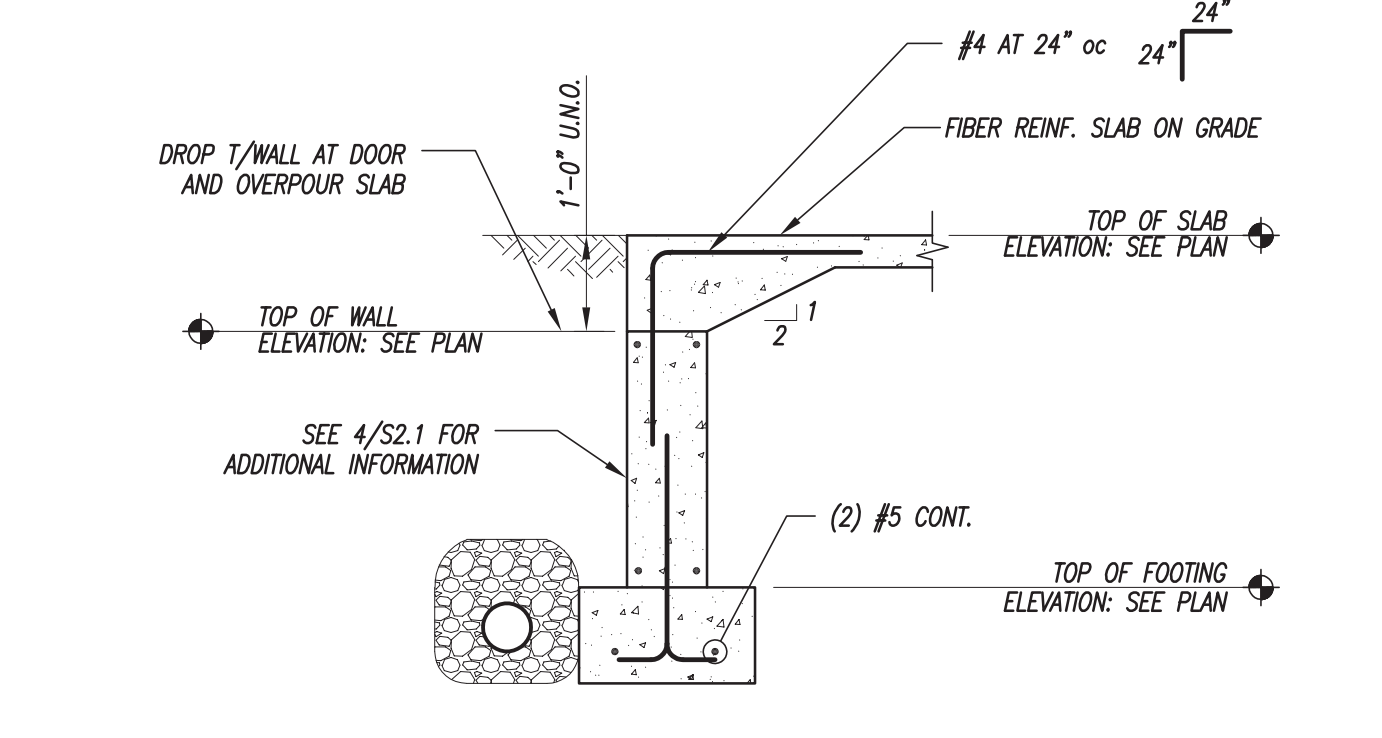

**10 SECTION**  
1/2" = 1'-0"

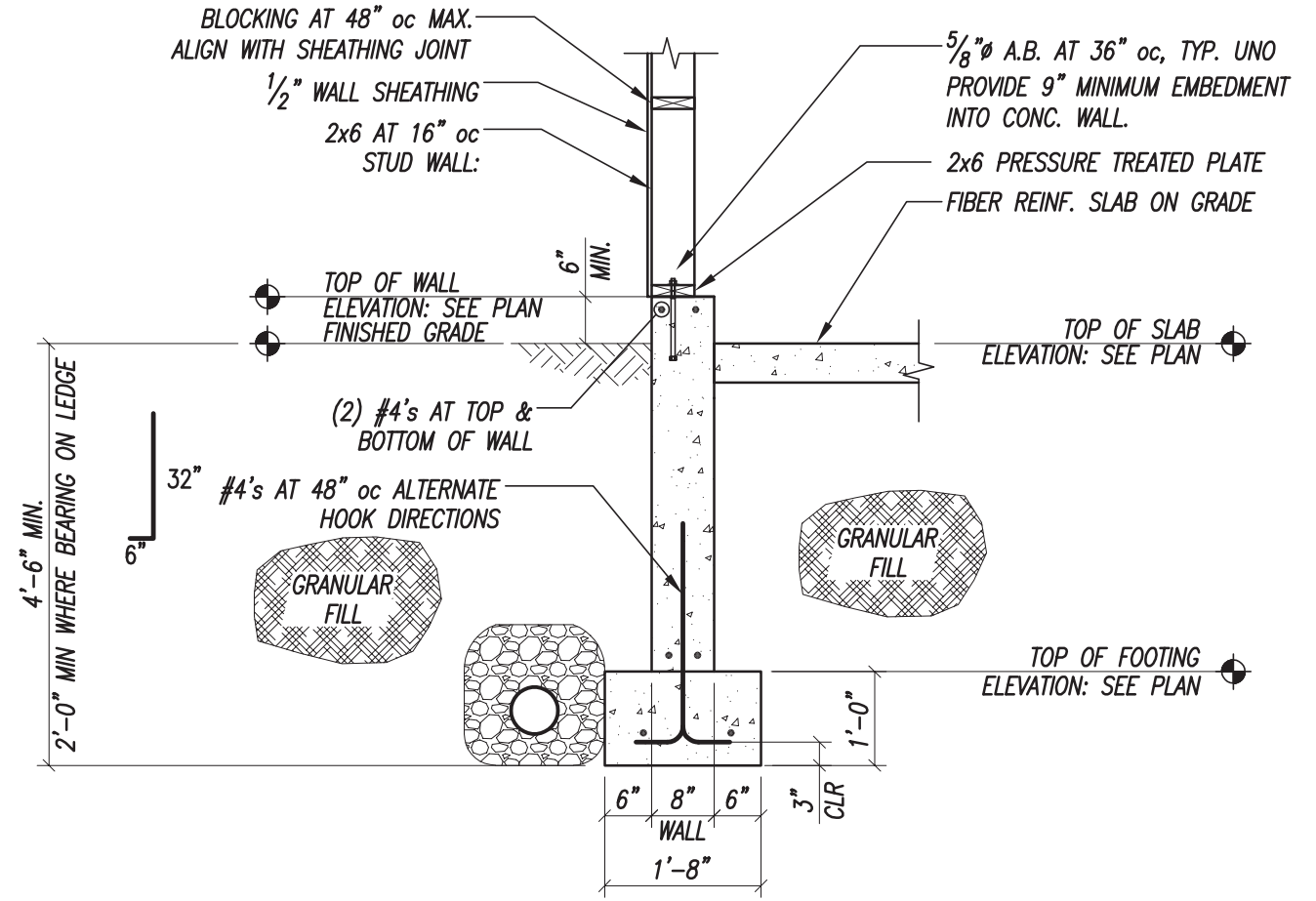

**11 SECTION**  
1/2" = 1'-0"

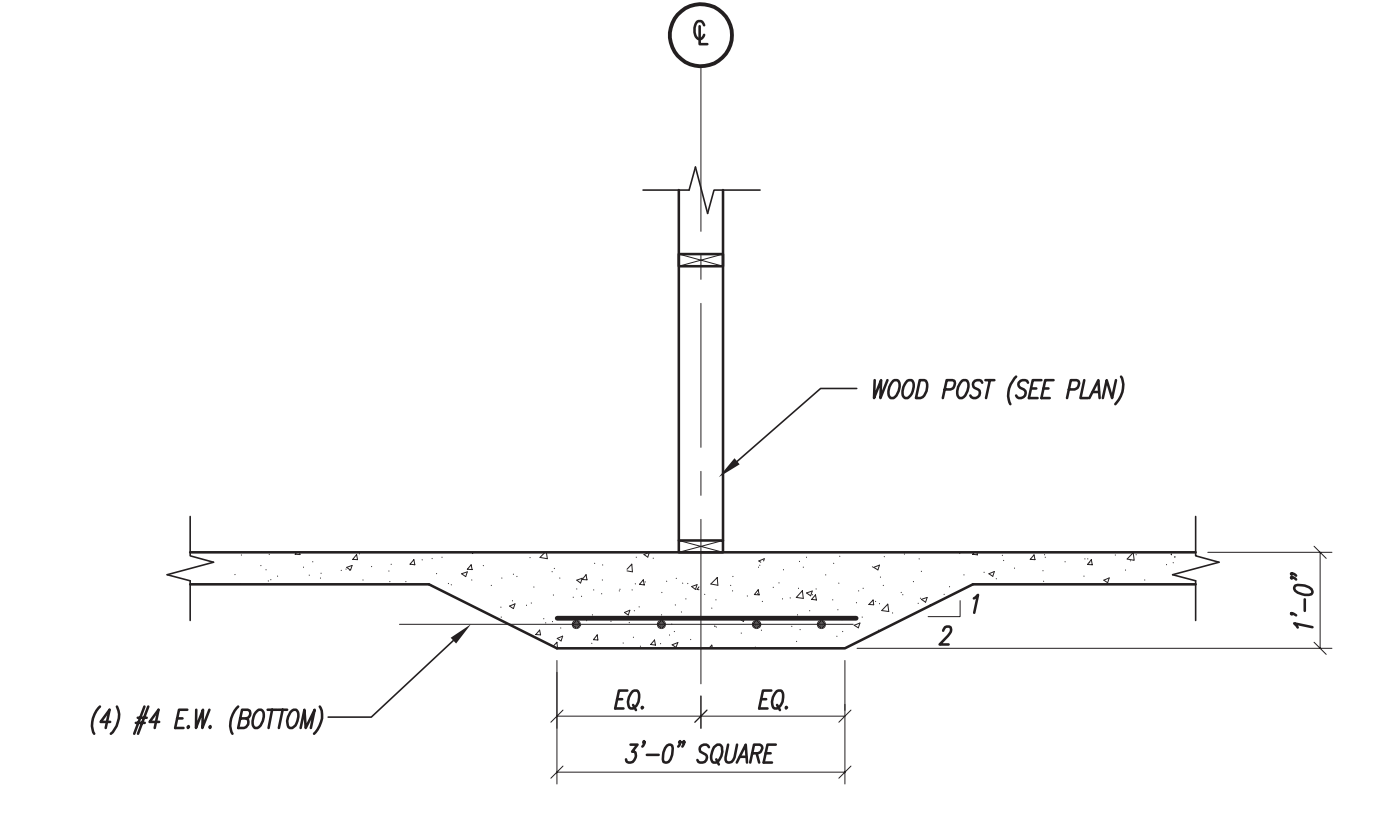

**12 SECTION**  
1/2" = 1'-0"

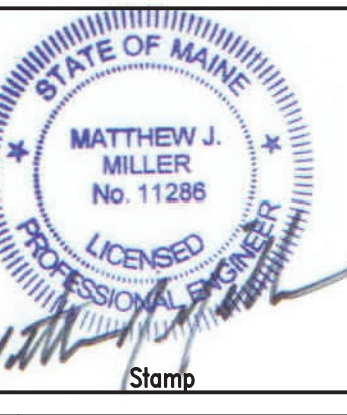

Revisions:	Description:
No:	Date:

**M<sup>2</sup> STRUCTURAL ENGINEERING, P.C.**  
23 Thornbury Way  
Windham, ME 04062  
(207) 892-0983  
info@m2se.com

Client: **AMY FARRELL**

Sheet Title: **FOUNDATION SECTIONS AND DETAILS**  
Project Name: **FARRELL RESIDENCE GREAT DIAMOND ISLAND, PORTLAND, MAINE**

Project No:	17079
Designed By:	MJM
Drawn By:	MJM
Checked By:	MJM
Scale:	AS NOTED
Date:	09/25/2017