

DISPLAY THIS CARD ON PRINCIPAL FRONTAGE OF WORK



CITY OF PORTLAND BUILDING PERMIT

This is to certify that LANGDON STREET REAL ESTATE
INC. - INTERMODAL TRANSPORTATION HUB

Located At 100 SEWALL ST

CBL: 077- A-001-001

Job ID: 2012-04-3831-ALTCOMM

has permission to Change several doors for boarding, exiting and main entrance vestibule. Create new hall next to conference provided that the person or persons, firm or corporation accepting this permit shall comply with all of the provisions of the Statues of Maine and of the Ordinances of the City of Portland regulating the construction, maintenance and use of the buildings and structures, and of the application on file in the department.

Notification of inspection and written permission procured before this building or part thereof is lathed or otherwise closed-in. 48 HOUR NOTICE IS REQUIRED.

A final inspection must be completed by owner before this building or part thereof is occupied. If a certificate of occupancy is required, it must be

Fire Prevention Officer

[Signature] *5/15/12*

Code Enforcement Officer / Plan Reviewer

THIS CARD MUST BE POSTED ON THE STREET SIDE OF THE PROPERTY
PENALTY FOR REMOVING THIS CARD

closed

SCANNED

City of Portland, Maine - Building or Use Permit Application

389 Congress Street, 04101 Tel: (207) 874-8703, FAX: (207) 8716

Job No: 2012-04-3831-ALTCOMM	Date Applied: 4/23/2012	CBL: 077- A-001-001	
Location of Construction: 100 SEWALL ST	Owner Name: LANGDON STREET REAL ESTATE INC.	Owner Address: 7 LANGDION ST CONCORD, NH 03301	Phone:
Business Name:	Contractor Name: Perspective CM- Bill Bridges	Contractor Address: 7 Collins Pond RD, Windham, ME 04062	Phone: 577-0297
Lessee/Buyer's Name:	Phone:	Permit Type: BLDG ALT	Zone: B-5
Past Use: Intermodel Transportation Hub	Proposed Use: Same: Intermodel Transportation Hub – interior conference room alterations – new automatic doors – fix crumbly curbs and sidewalks	Cost of Work: \$47,500.00	CEO District:
		Fire Dept: 5/2/12 <input checked="" type="checkbox"/> Approved w/ conditions <input type="checkbox"/> Denied <input type="checkbox"/> N/A	Inspection: Use Group: A-3 Type: SA/2C IBC-2009 Signature: <i>[Signature]</i> 5/5/12
Proposed Project Description: curb/walk maintenance, conference room alteration		Pedestrian Activities District (P.A.D.)	
Permit Taken By: Gayle		Zoning Approval	

<p>1. This permit application does not preclude the Applicant(s) from meeting applicable State and Federal Rules.</p> <p>2. Building Permits do not include plumbing, septic or electrical work.</p> <p>3. Building permits are void if work is not started within six (6) months of the date of issuance. False informatin may invalidate a building permit and stop all work.</p>	Special Zone or Reviews <input type="checkbox"/> Shoreland <input type="checkbox"/> Wetlands <input type="checkbox"/> Flood Zone <input type="checkbox"/> Subdivision <input type="checkbox"/> Site Plan <input type="checkbox"/> Maj <input type="checkbox"/> Min <input type="checkbox"/> MM Date: <i>OK 4/24/12</i>	Zoning Appeal <input type="checkbox"/> Variance <input type="checkbox"/> Miscellaneous <input type="checkbox"/> Conditional Use <input type="checkbox"/> Interpretation <input type="checkbox"/> Approved <input type="checkbox"/> Denied Date:	Historic Preservation <input checked="" type="checkbox"/> Not in Dist or Landmark <input type="checkbox"/> Does not Require Review <input type="checkbox"/> Requires Review <input type="checkbox"/> Approved <input type="checkbox"/> Approved w/Conditions <input type="checkbox"/> Denied Date: <i>[Signature]</i>
	CERTIFICATION		

I hereby certify that I am the owner of record of the named property, or that the proposed work is authorized by the owner of record and that I have been authorized by the owner to make this application as his authorized agent and I agree to conform to all applicable laws of this jurisdiction. In addition, if a permit for work described in the application is issued, I certify that the code official's authorized representative shall have the authority to enter all areas covered by such permit at any reasonable hour to enforce the provision of the code(s) applicable to such permit.

SIGNATURE OF APPLICANT	ADDRESS	DATE	PHONE
RESPONSIBLE PERSON IN CHARGE OF WORK, TITLE		DATE	PHONE



PORTLAND MAINE

Strengthening a Remarkable City, Building a Community for Life • www.portlandmaine.gov

Acting Director of Planning and Urban Development
Gregory Mitchell

Job ID: 2012-04-3831-ALTCOMM

Located At: 100 SEWALL ST

CBL: 077- A-001-001

Conditions of Approval:

Fire

1. Installation shall comply with City Code Chapter 10.
2. This permit is being approved on the basis of the plans submitted. Any deviation from the plans would require amendments and approval.
3. Any Fire alarm or Sprinkler systems shall be reviewed by a licensed contractor(s) for code compliance. All fire alarm installation and servicing companies shall have a Certificate of Fitness from the Fire Department. Compliance letters are required.
4. A separate Fire Alarm Permit is required for new systems; or for work effecting more than 5 fire alarm devices; or replacement of a fire alarm panel with a different model. This review does not include approval of fire alarm system design or installation.
5. Fire Alarm system shall be maintained. If system is to be off line over 4 hours a fire watch shall be in place. Dispatch notification required 874-8576.
6. A separate Suppression System Permit is required for all new suppression systems or sprinkler work effecting more than 20 heads. This review does not include approval of sprinkler system design or installation.
7. Sprinkler protection shall be maintained. Where the system is to be shut down for maintenance or repair, the system shall be checked at the end of each day to insure the system has been placed back in service.
8. System acceptance and commissioning must be coordinated with alarm and suppression system contractors and the Fire Department. Call 874-8703 to schedule.
9. A Knox Box is required.
10. Fire extinguishers are required per NFPA 1.
11. Assembly EXIT doors shall swing in the direction of egress travel. The only latch or lock permitted on any assembly EXIT door will be listed panic or fire exit hardware and powered door leaf operation shall comply with NFPA 101:7.2.1.9 and NFPA 101:7.2.1.14. Letter of compliance required.
12. All means of egress to remain accessible at all times.
13. Emergency lights and exit signs are required. Emergency lights and exit signs are required to be labeled in relation to the panel and circuit and on the same circuit as the lighting for the area they serve.
14. Any cutting and welding done will require a Hot Work Permit from Fire Department.
15. New walls in structure are to be labeled according to fire resistance rating. IE; 1 hr. / 2 hr. / smoke proof.

Building

1. Application approval based upon information provided by applicant. Any deviation from approved plans requires separate review and approval prior to work.
2. Separate permits are required for any electrical, plumbing, sprinkler, fire alarm, HVAC systems, heating appliances, including pellet/wood stoves, commercial hood exhaust systems and fuel tanks. Separate plans may need to be submitted for approval as a part of this process.

BUILDING PERMIT INSPECTION PROCEDURES

Please call 874-8703 or 874-8693 (ONLY)

or email: buildinginspections@portlandmaine.gov

With the issuance of this permit, the owner, builder or their designee is required to provide adequate notice to the city of Portland Inspections Services for the following inspections. Appointments must be requested 48 to 72 hours in advance of the required inspection. The inspection date will need to be confirmed by this office.

- **Please read the conditions of approval that is attached to this permit!! Contact this office if you have any questions.**
- **Permits expire in 6 months. If the project is not started or ceases for 6 months.**
- **If the inspection requirements are not followed as stated below additional fees may be incurred due to the issuance of a "Stop Work Order" and subsequent release to continue.**

Close In Elec/Plmb/Frame prior to insulate or gyp

Final Inspection

The project cannot move to the next phase prior to the required inspection and approval to continue, REGARDLESS OF THE NOTICE OF CIRCUMSTANCES.

IF THE PERMIT REQUIRES A CERTIFICATE OF OCCUPANCY, IT MUST BE PAID FOR AND ISSUED TO THE OWNER OR DESIGNEE BEFORE THE SPACE MAY BE OCCUPIED.



2012 04 3831 68

General Building Permit Application

B-S

If you or the property owner owes real estate or personal property taxes or user charges on any property within the City, payment arrangements must be made before permits of any kind are accepted.

100 Sewall

Location/Address of Construction: 100 THOMPSON'S POINT CONNECTOR		
Total Square Footage of Proposed Structure/Area 500 SF	Square Footage of Lot	Number of Stories
Tax Assessor's Chart, Block & Lot Chart# Block# Lot# 77 A 001	Applicant * <u>must</u> be owner, Lessee or Buyer* Name PERSPECTIVE CM Address 7 COLLINS FOND RD. City, State & Zip WINDHAM, ME 04062	Telephone: 207.577.0297 (M)
Lessee/DBA (If Applicable) RECEIVED APR 23 2012 Dept. of Building Inspections City of Portland Maine	Owner (if different from Applicant) Name CONCORD COACHLINES Address 100 THOMPSON'S POINT City, State & Zip PORTLAND, ME Langdon Street #102	Cost Of Work: \$ 47,500.00 C of O Fee: \$ 5/ Total Fee: \$ 500.00
Current legal use (i.e. single family) TRANSPORTATION Number of Residential Units _____ If vacant, what was the previous use? _____ Proposed Specific use: SAME Is property part of a subdivision? _____ If yes, please name _____ Project description: CONF. RM. ALTERATIONS; CURB: WALK MAINTENANCE; AUTOMATIC DOORS NEW		
Contractor's name: PERSPECTIVE CM		
Address: * 7 COLLINS FOND RD.		
City, State & Zip WINDHAM, ME 04062		Telephone: 577.0297
Who should we contact when the permit is ready: BILL BRIDGES		Telephone: 577.0297
Mailing address: *		

Please submit all of the information outlined on the applicable Checklist. Failure to do so will result in the automatic denial of your permit.

In order to be sure the City fully understands the full scope of the project, the Planning and Development Department may request additional information prior to the issuance of a permit. For further information or to download copies of this form and other applications visit the Inspections Division on-line at www.portlandmaine.gov, or stop by the Inspections Division office, room 315 City Hall or call 874-8703.

I hereby certify that I am the Owner of record of the named property, or that the owner of record authorizes the proposed work and that I have been authorized by the owner to make this application as his/her authorized agent. I agree to conform to all applicable laws of this jurisdiction. In addition, if a permit for work described in this application is issued, I certify that the Code Official's authorized representative shall have the authority to enter all areas covered by this permit at any reasonable hour to enforce the provisions of the codes applicable to this permit.

Signature: Date: **4.23.12**

This is not a permit; you may not commence ANY work until the permit is issued



PORTLAND MAINE

Strengthening a Remarkable City, Building a Community for Life • www.portlandmaine.gov

Receipts Details:

Tender Information: Check , BusinessName: Perspective Construction Management, Check Number: 2358

Tender Amount: 500.00

Receipt Header:

Cashier Id: gguertin

Receipt Date: 4/23/2012

Receipt Number: 43162

Receipt Details:

Referance ID:	6223	Fee Type:	BP-Constr
Receipt Number:	0	Payment Date:	
Transaction Amount:	500.00	Charge Amount:	500.00
Job ID: Job ID: 2012-04-3831-ALTCOMM - curb/walk maintenance, conference room alteration			
Additional Comments: 100 sewall			

Thank You for your Payment!

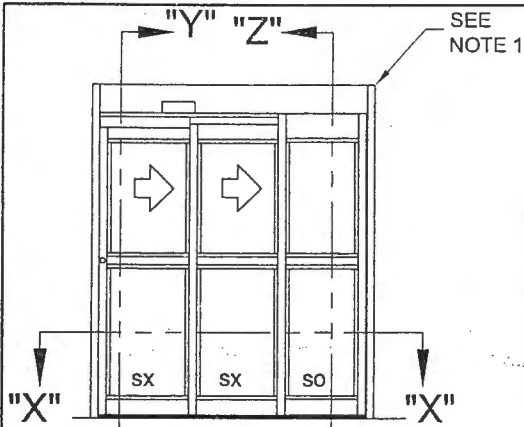

- NOTES:
1. POWER TO HEADER WILL BE 115V, 5 AMP PER OPERATOR PROVIDED BY ELECTRICAL CONTRACTOR.
 2. FINISH: 313 DARK BRONZE ANODIZED
 3. GLASS STOPS FOR 1" GLASS.
 4. 1/2" TALL THRESHOLD BETWEEN JAMBS.
 5. FAIL SECURE ELEC. LOCK INSTALLED.
 6. ADAMS RITE SURFACE APPLIED PUSHBAR.
 7. ALL DIMENSIONS IN INCHES.

Exterior Elevation
(1) Unit Thus - Conference Room

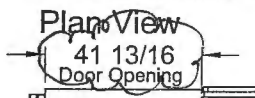
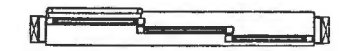

Plan View (Doors Open)

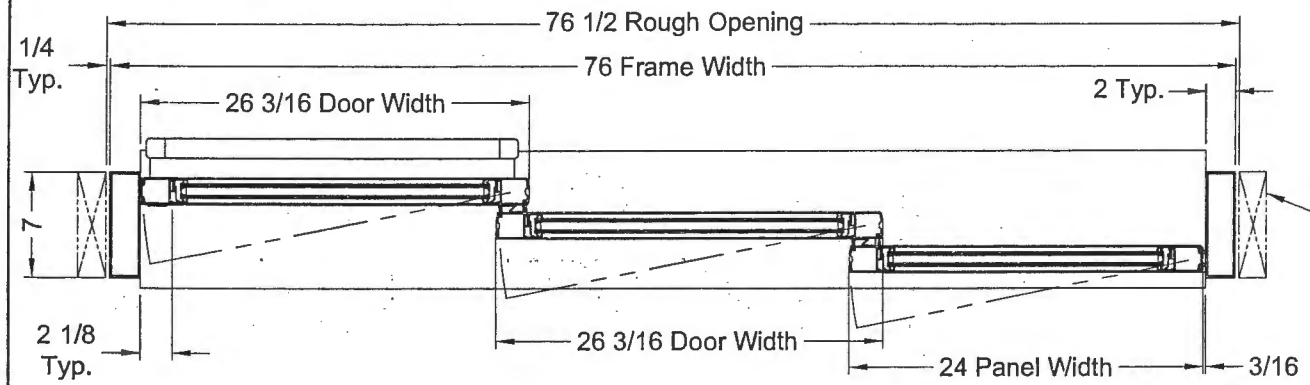

Section "X"- "X"

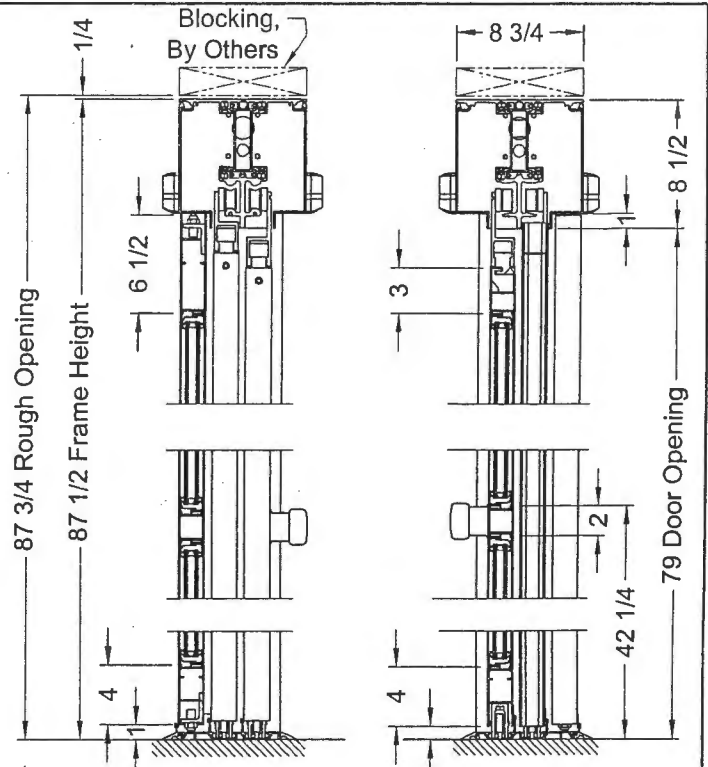

Section "Z"- "Z" Section "Y"- "Y"

Blocking,
by Others

GT1175 SINGLE TELESCOPIC SLIDER RIGHT HAND FULL OPEN			
ELEVATIONS AND SECTIONS			
PORTLAND TRANSPORTATION			
NORTHEAST DOOR CORPORATION			
GYRO TECH			
882 W18717 GEMINI DRIVE P.O. BOX 906 MUSKEGOO, WISCONSIN 53150 PHONE: 877-522-2554 FAX: 888-678-3319			
DATE: BK	REV: 3-19-12	APPROVED BY:	DATE:
CONTRACT NUMBER:	DRAWING NUMBER:	11488	

Bus Entry

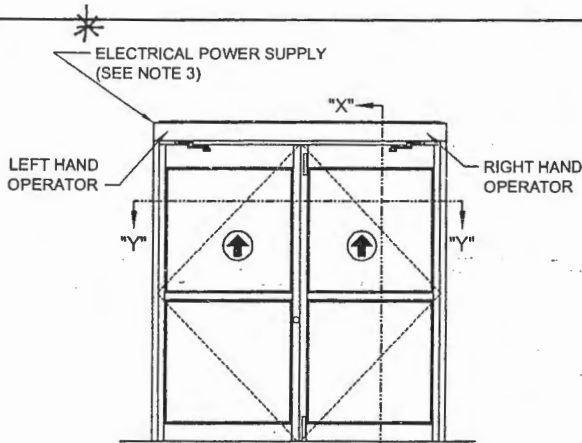

INTERIOR ELEVATION

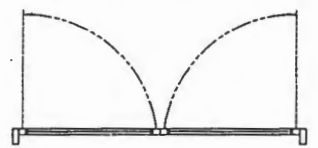

OPERATOR INTERIOR SIDE PLAN VIEW

- NOTES:**
1. GUIDE RAILS, MATS, PUSH PLATES AND VARIOUS ELECTRONIC DEVICES FOR THE DOOR ACTIVATION AND CONTROL ARE OPTIONAL. CONSULT WITH YOUR NABCO/GYRO TECH ENTRANCES DISTRIBUTOR.
 2. ALL PEDESTRIAN DOORS MUST BE SET UP TO OPERATE IN ACCORDANCE WITH ANSI 156.10 DEPENDING ON APPLICATION.
 3. ELECTRICAL CONTRACTOR TO PROVIDE 115V, 5 AMP, SINGLE PHASE SERVICE IN ACCORDANCE WITH LOCAL CODES TO EITHER END OF THE HEADER.
 4. ALL DIMENSIONS ARE IN INCHES
 5. FINISH: 313 DARK BRONZE
 6. STANDARD UNITS PREPPED FOR 1/4" GLAZING, LOCK AND FLUSH BOLTS FOR SECURITY, PUSH BAR ON THE INTERIOR AND PULL HANDLE ON THE EXTERIOR

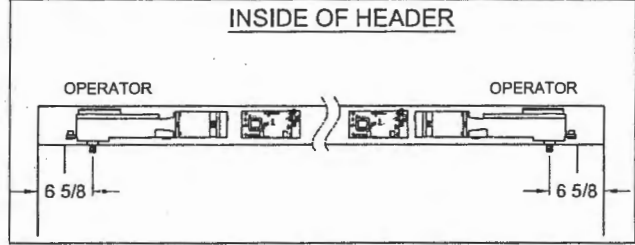

INSIDE OF HEADER

EXTERIOR SIDE

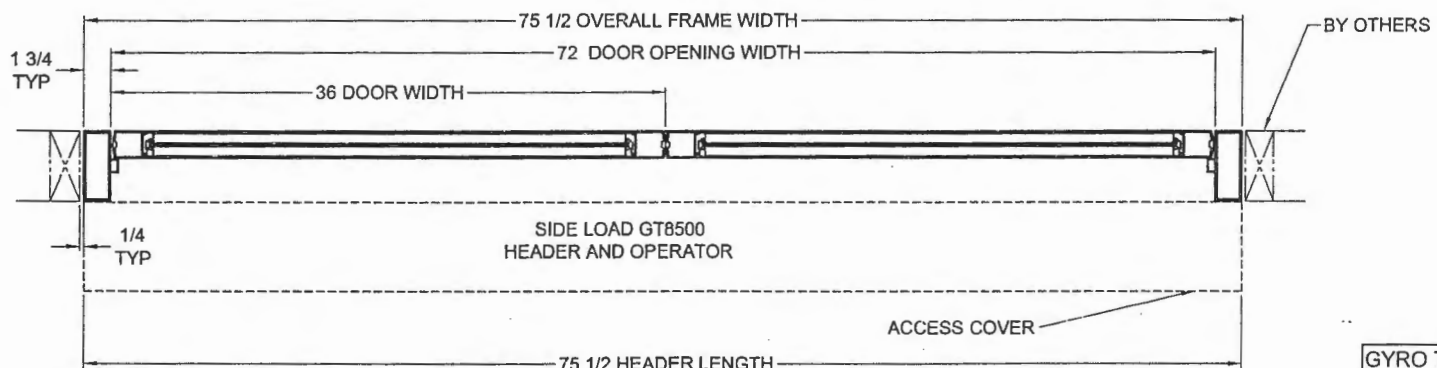

INTERIOR SIDE

SECTION "Y-Y"

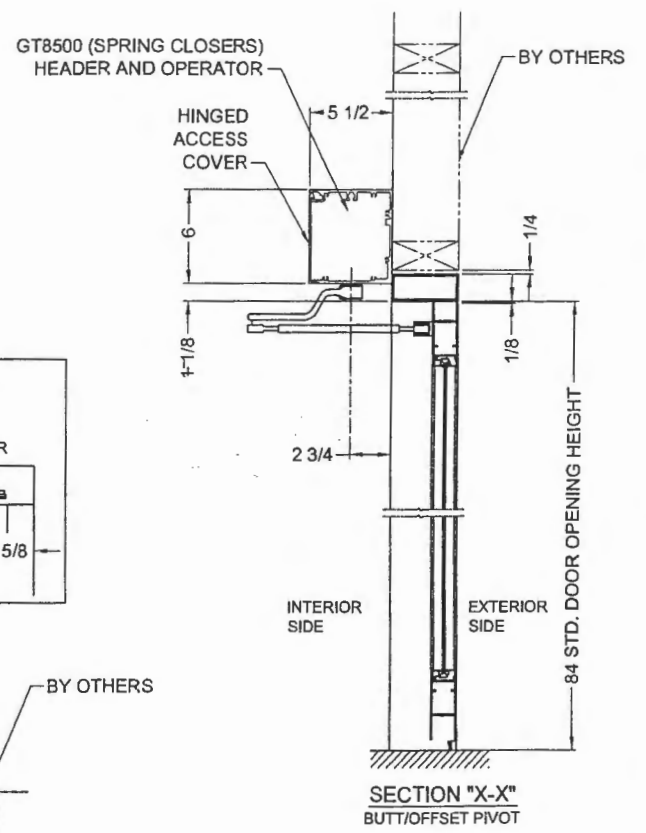

GYRO TECH GT8500 SIDE LOAD HEADER SIMULTANEOUS PAIR OUTSWING CONVERSION UNIT

NABCO		SECTIONS & ELEVATIONS	
GYRO TECH		PORTLAND TRANSPORTATION	
582 W18717 GEMINI DRIVE P.O. BOX 908 MUSKEGO, WISCONSIN 53150 PHONE: 877 622-2694 FAX: 888 679-3319		DATE: 3/19/12	PROJECT NO:
DESIGNED BY: LLKN	DATE:	PROJECT NO:	DATE:
CONTRACT NUMBER:	REVISED BY:	REVISED DATE:	REVISED NO:
			8500 11491

11491

(2) wireless remotes

*Bus Exit Boarding
pair swing doors*

84-B-CDF DRAWING(2)1020011491 078008 884 P AIR OUT 75-12.00(1).dwg 3/19/12 11:52:23 PM

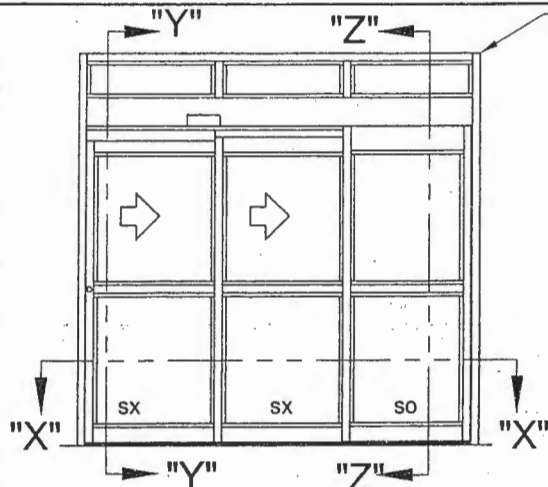

SEE
NOTE 1

NOTES:

1. POWER TO HEADER WILL BE 115V, 5 AMP PER OPERATOR PROVIDED BY ELECTRICAL CONTRACTOR.
2. FINISH: 313 DARK BRONZE ANODIZED
3. GLASS STOPS FOR 1" GLASS.
4. 1/2" TALL THRESHOLD BETWEEN JAMBS.
5. FAIL SECURE ELEC. LOCK INSTALLED.
6. ADAMS RITE SURFACE APPLIED PUSHBAR.
7. ALL DIMENSIONS IN INCHES.

Exterior Elevation
(1) Unit Thus - Vest. In



Plan View

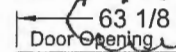

Plan View (Doors Open)

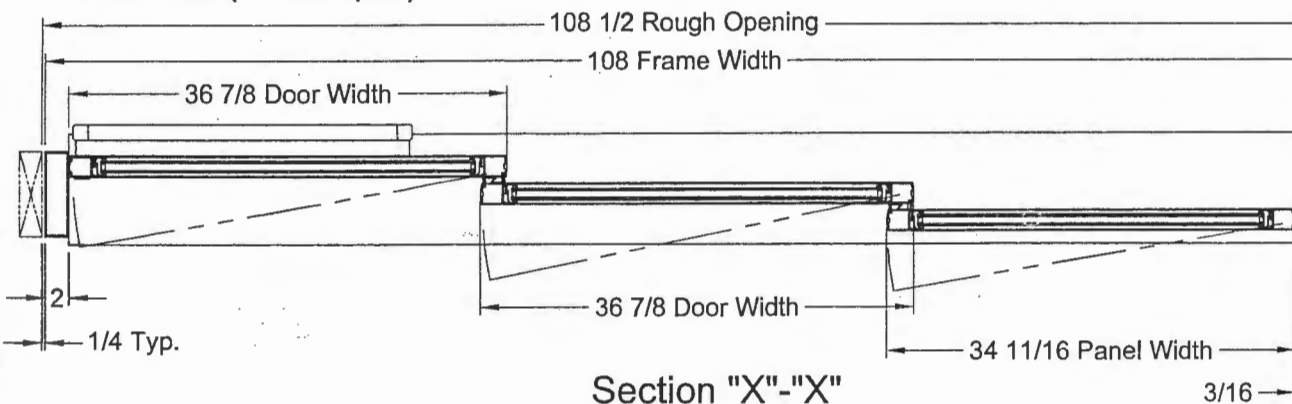

Section "X"- "X"

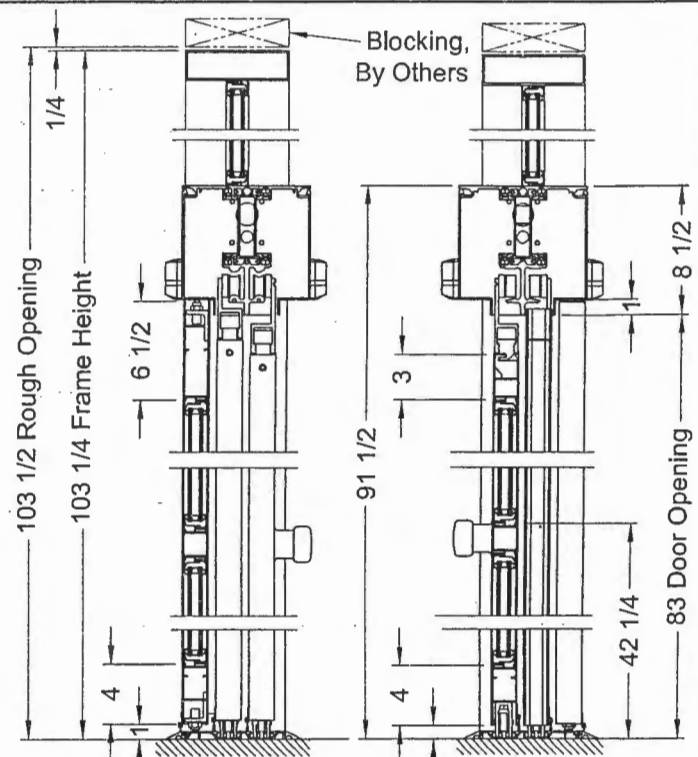

Section "Z"- "Z" Section "Y"- "Y"

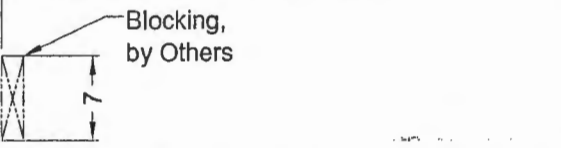

GT1175 SINGLE TELESCOPIC SLIDER RIGHT HAND FULL OPEN			
NABCO			
GYRO TECH			
<small>882 W18717 GEMINI DRIVE P.O. BOX 906 MUSKEGO, WISCONSIN 53150 PHONE: 877 622-2094 FAX: 888 678-3319</small>			
DATE: 3-19-12	PROJECT: PORTLAND TRANSPORTATION	DRAWN BY: 11489	
BY: BK	CHECKED BY:	NORTHEAST DOOR CORPORATION	
ELEVATIONS AND SECTIONS			

INTERIOR VESTIBULE

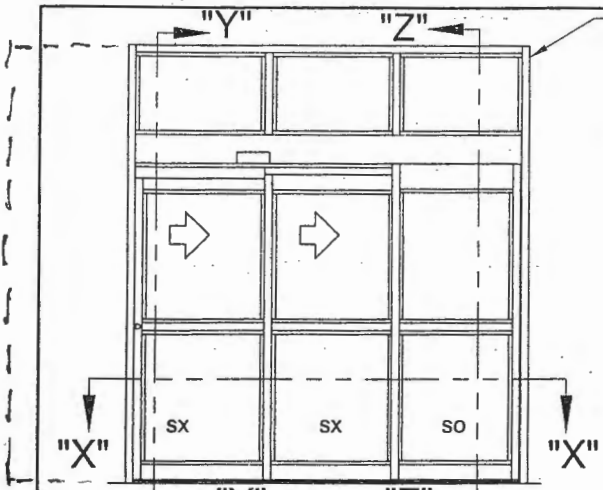

- NOTES:
1. POWER TO HEADER WILL BE 115V, 5 AMP PER OPERATOR PROVIDED BY ELECTRICAL CONTRACTOR.
 2. FINISH: 313 DARK BRONZE ANODIZED
 3. GLASS STOPS FOR 1" GLASS.
 4. 1/2" TALL THRESHOLD BETWEEN JAMBS.
 5. FAIL SECURE ELEC. LOCK INSTALLED.
 6. ADAMS RITE SURFACE APPLIED PUSHBAR.
 7. ALL DIMENSIONS IN INCHES.

Exterior Elevation
(1) Unit Thus - Vest. Ext.

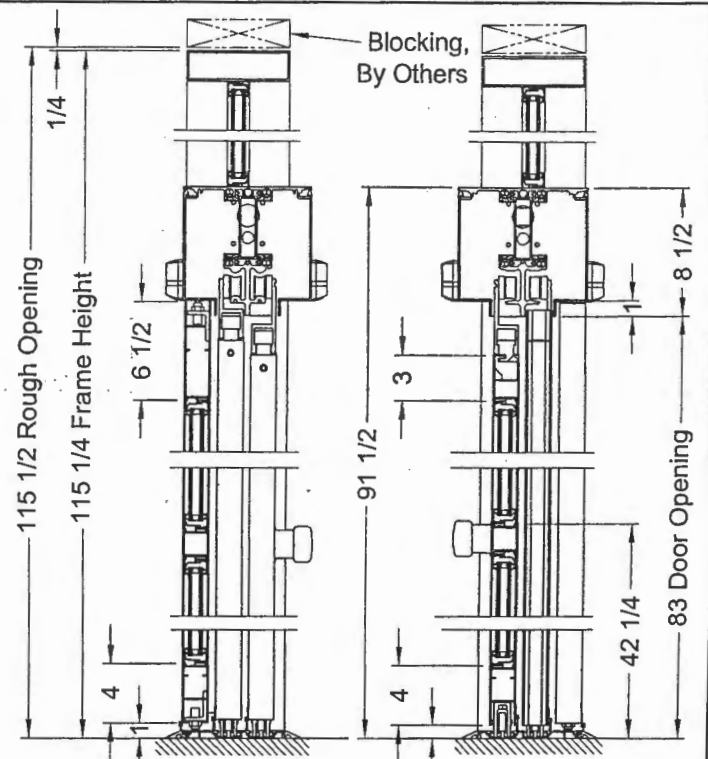
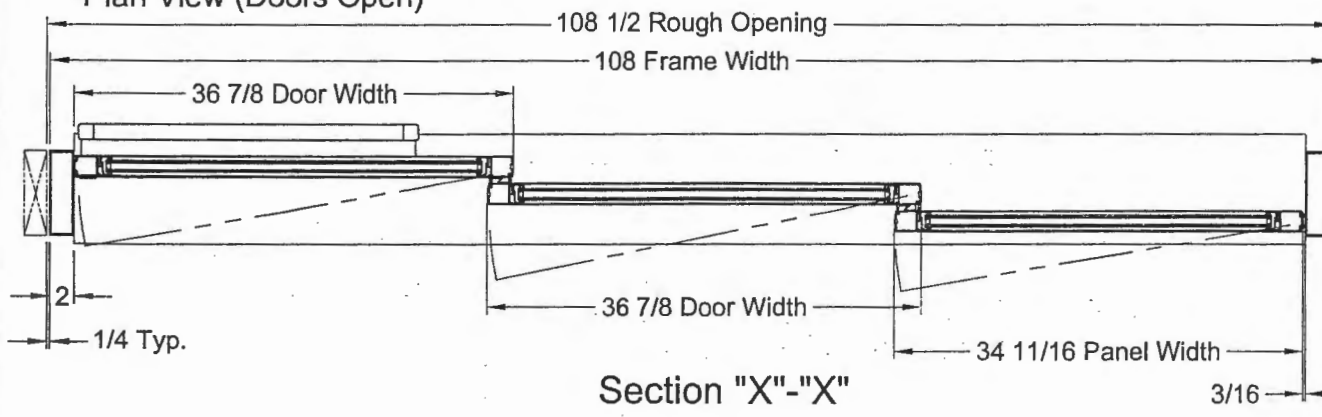
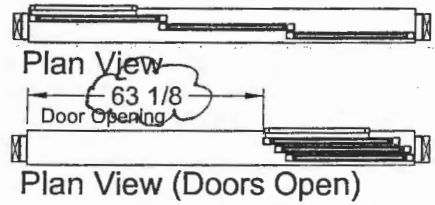

Section "Z"-"Z" Section "Y"-"Y"
Blocking, by Others

GT1175 SINGLE TELESCOPIC SLIDER RIGHT HAND FULL OPEN			
ELEVATIONS AND SECTIONS			
PORTLAND TRANSPORTATION			
NORTHEAST DOOR CORPORATION			
GYRO TECH			
882 W18717 GEMINI DRIVE P.O. BOX 908 MUSKEGO, WISCONSIN 53150 PHONE: 877 822-2694 FAX: 886 879-3318			
REV	DATE	BY	CHKD
BK	3-19-12		
11490			

EXTERIOR VESTIBULE

Project Name: Portland Transportation NE Door

(Frame 1) - 1 Thus

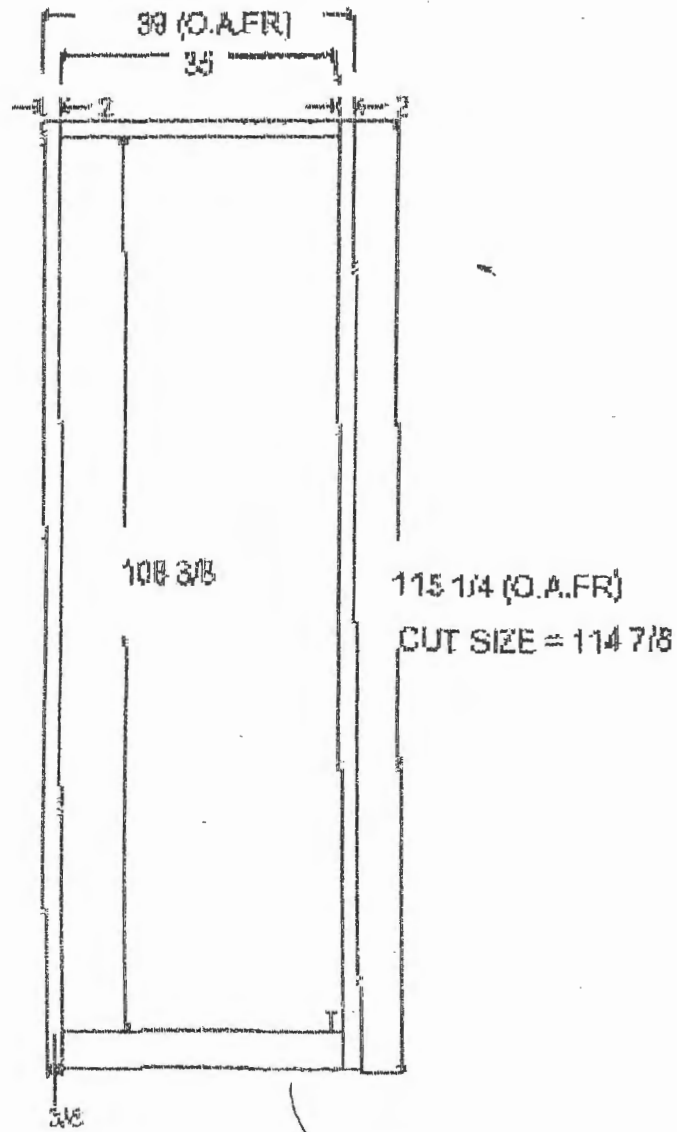

(Frame 2) - 1 Thus

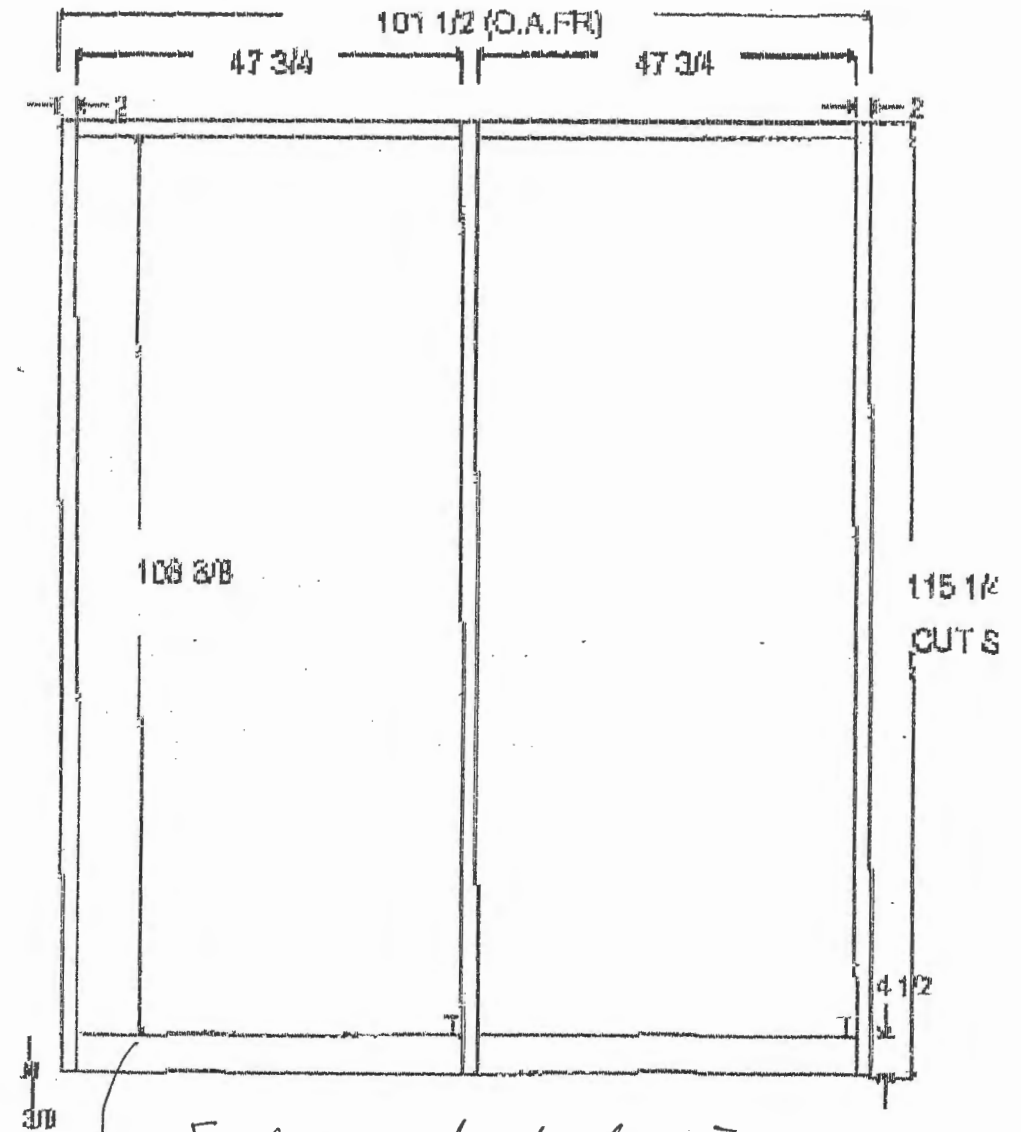

[replaces current entry doors]



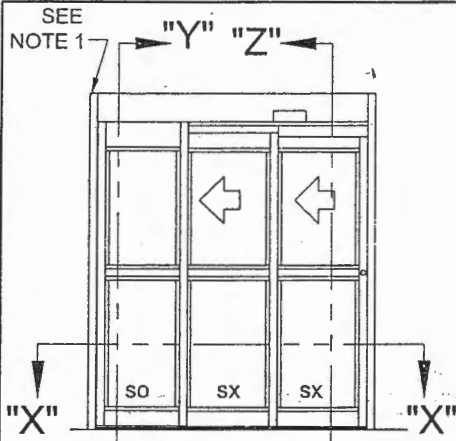

- NOTES:
1. POWER TO HEADER WILL BE 115V, 5 AMP PER OPERATOR PROVIDED BY ELECTRICAL CONTRACTOR.
 2. FINISH: 313 DARK BRONZE ANODIZED
 3. GLASS STOPS FOR 1" GLASS.
 4. 1/2" TALL THRESHOLD BETWEEN JAMBS.
 5. FAIL SECURE ELEC. LOCK INSTALLED.
 6. ADAMS RITE SURFACE APPLIED PUSHBAR.
 7. ALL DIMENSIONS IN INCHES.

Exterior Elevation
(1) Unit Thus - Bus Entry

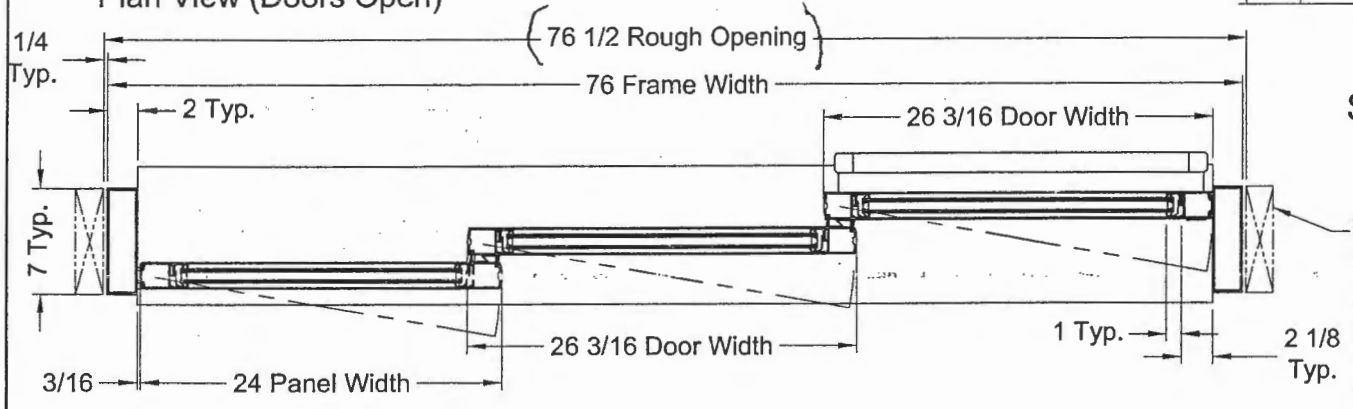
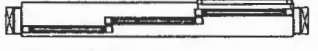

Section "X"- "X"

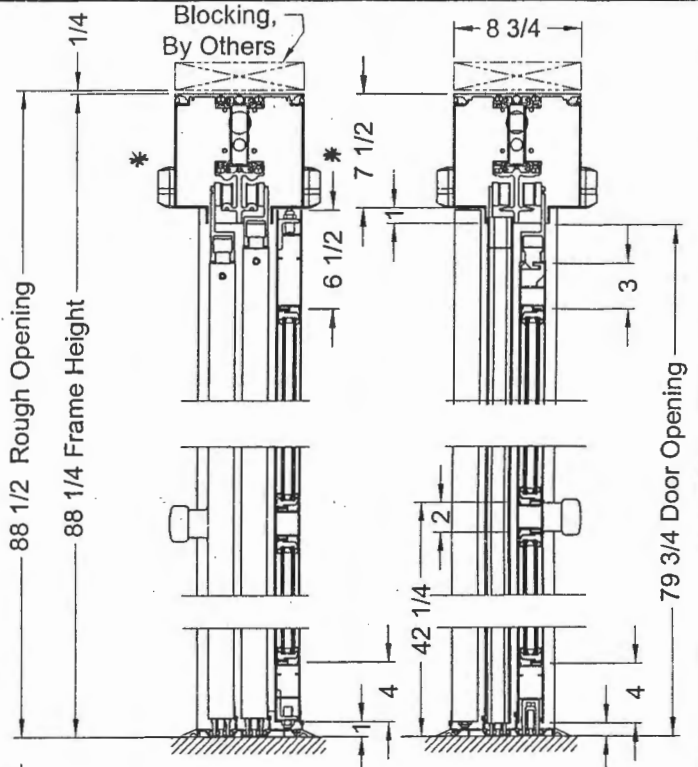

Section "Y"- "Y" Section "Z"- "Z"

GT1175 SINGLE TELESCOPIC SLIDER LEFT HAND FULL OPEN			
ELEVATIONS AND SECTIONS			
PORTLAND TRANSPORTATION			
NORTHEAST DOOR CORPORATION			
GYRO TECH			
582 W18717 GEMINI DRIVE P.O. BOX 908 MUSKEGO, WISCONSIN 53150 PHONE: 877 622-2694 FAX: 888 679-3319			
DATE: BK	DATE: 3-19-12	PROJECT: 11487	DATE: 11487

De-boarding New Hallway Conference Rooms

5-15-12 DWM/BKL Bill 577-0297 close-in OK

6-1-12 DWM/BKL/cap+Pirone Bill Final OK