

# SHR 3205RD

## Heat Recovery Ventilator

Product #: 40225



Suitable for very large residential or small commercial applications, the compact SHR 3205RD comes with access panels on both sides of the unit for installation versatility. The unit is designed for higher static pressure and higher airflow applications. The unit brings a continuous supply of fresh air into a home while exhausting an equal amount of contaminated air. During winter, fresh incoming air is tempered by the heat that is transferred from the outgoing air so you save on energy costs, while during summer, the incoming air is pre-cooled if the house is equipped with an air cooling system. The SHR 3205RD is equipped with automatic defrost mechanisms so you can use your HRV all year long.

### Features

- Compact design
- Backward curved blade motors
- Electrostatic filters (washable)
- Two (2) aluminum heat recovery core
- External screw type dry contacts
- Access doors on two sides of the cabinet for multiple installation arrangements and for better serviceability
- Improved core guide channels for easy removal of core
- Weighs 80 lbs (36 Kg)

### Optional controls

- ECO-Touch™ (#44929) – Programmable Touch Screen Wall Control
- EDF7 (#44883) – Electronic multi-function dehumidistat
- RTS3 (#40376) – 20/40/60 minute over-ride
- MDEH1 (#40172) – Dehumidistat

### Specifications

- Duct size – 8" (203 mm)
- Voltage/Phase – 120/1
- Power rated – 300 W
- Amp – 2.5 A
- Average airflow – 259 cfm (122 L/s)  
@ 0.4" P<sub>s</sub> (100Pa)

### Motors

Four (4) factory-balanced fans with backward curved blades. Motors come with permanently lubricated, sealed ball-bearings to guarantee long life and maintenance-free operation.

### Heat Recovery Core

Two (2) aluminum heat recovery core covered by a limited lifetime warranty. Core dimensions are 12" x 12" (305 x 305 mm) with a 11,5" (292 mm) depth. Our heat exchangers are designed and manufactured to withstand extreme temperature variations.

### Defrost

During the defrost sequence, a motorized damper temporarily blocks the incoming fresh air stream so that the warm air from the house can circulate through the HRV. The exhaust blower shuts down and the supply blower switches into high speed to maximize the effectiveness of the defrost strategy. During this cycle, household odors from the kitchen or bathroom are prevented from entering the home and the unit will not create negative pressure.

### Serviceability

Core, filters, fans, drain pan and electrical panel can be accessed easily from the access panel. Core conveniently slides out with only 14" (356 mm) clearance

### Case

24 gauge galvanized steel. Baked powder coated paint.

### Insulation

Cabinet is fully insulated with 1" (25 mm) high density expanded polystyrene.

### Filters

Four (4) washable electrostatic panel type air filters 11,5" (292mm) x 11,4" (290 mm) x 0.125" (3mm).

### Controls

External three (3) position (Low/Stand By/Medium) rocker switch that will offer continuous ventilation. Fantech offers a variety of external controls. (see optional controls)

### Installation

Unit is typically hung by using installation kit supplied with unit. Mounting bolts provided on top four (4) corners of unit.

### Warranty

Limited lifetime on aluminum core, 7 year on motors, and 5 year on parts.

## Dimensions & Airflow

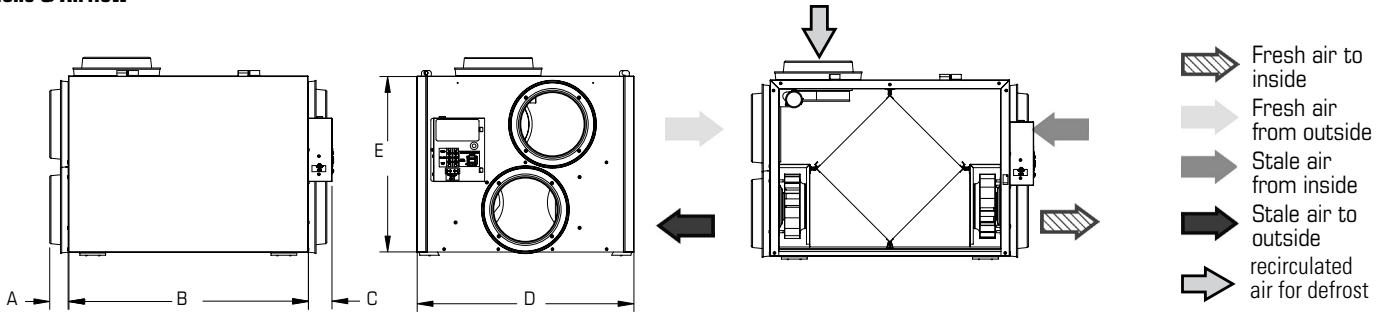

Model	A		B		C		D		E	
	in	mm	in	mm	in	mm	in	mm	in	mm

SHR3205RD 2 1/4 57 27 7/8 708 2 3/4 70 25 1/8 638 20 1/2 521

Clearance of 14" (356mm) in front of the unit is recommended for removal of core. All units feature three foot plug-in power cord with 3-prong plug.

## Ventilation Performance

in. wg. (Pa)	0.4 (100)	0.6 (150)	0.8 (200)	1.0 (250)
	cfm (L/s)	cfm (L/s)	cfm (L/s)	cfm (L/s)
Net supply airflow	267 (126)	222 (104)	171 (80)	124 (58)
Gross supply airflow	275 (129)	229 (108)	176 (83)	128 (60)
Gross exhaust airflow	257 (121)	209 (99)	161 (76)	112 (53)

These measurements are for HIGH speed only

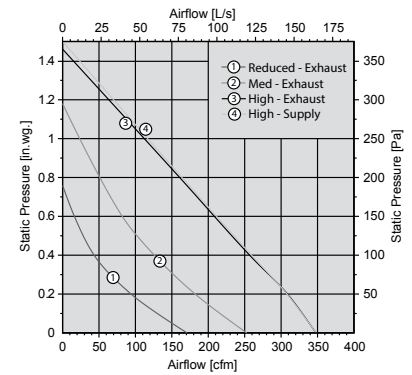

## Energy performance

	Supply temperature		Net airflow		Consumed power	Sensible recovery efficiency	Apparent sensible effectiveness	Latent recovery/moisture transfer
	°F	°C	cfm	L/s	W	%	%	-
Heating	32	0	118	56	136	66	77	0.02
	32	0	162	76	182	66	76	0.02
	32	0	248	116	272	64	74	0.03
	-13	-25	123	58	168	67	79	0.05

## Requirements and standards

- Complies with the UL 1812 requirements regulating the construction and installation of Heat Recovery Ventilators
- Complies with the CSA C22.2 no. 113 Standard applicable to ventilators
- Complies with the CSA F326 requirements regulating the installation of Heat Recovery Ventilators
- Technical data was obtained from published results of test relating to CSA C439 Standards
- HVI certified

## Contacts

Submitted by:	Date:
Quantity: Model:	Project #:
Comments:	
Location:	
Architect:	
Engineer:	Contractor:

## Distributed by:

United States 10048 Industrial Blvd. • Lenexa, KS 66215 • 1.800.747.1762 • www.fantech.net

Canada 50 Kanalfakt Way • Bouctouche, NB E4S 3M5 • 1.800.565.3548 • www.fantech.net

Fantech, reserves the right to modify, at any time and without notice, any or all of its products' features, designs, components and specifications to maintain their technological leadership position.

